



Artificially Induced Circulation of Lakes by Means of Compressed Air

William R. Schmitz; Arthur D. Hasler

Science, New Series, Vol. 128, No. 3331 (Oct. 31, 1958), 1088-1089.

Stable URL:

<http://links.jstor.org/sici?sici=0036-8075%2819581031%293%3A128%3A3331%3C1088%3AAICOLB%3E2.0.CO%3B2-%23>

Science is currently published by American Association for the Advancement of Science.

Your use of the JSTOR archive indicates your acceptance of JSTOR's Terms and Conditions of Use, available at <http://www.jstor.org/about/terms.html>. JSTOR's Terms and Conditions of Use provides, in part, that unless you have obtained prior permission, you may not download an entire issue of a journal or multiple copies of articles, and you may use content in the JSTOR archive only for your personal, non-commercial use.

Please contact the publisher regarding any further use of this work. Publisher contact information may be obtained at <http://www.jstor.org/journals/aaas.html>.

Each copy of any part of a JSTOR transmission must contain the same copyright notice that appears on the screen or printed page of such transmission.

JSTOR is an independent not-for-profit organization dedicated to creating and preserving a digital archive of scholarly journals. For more information regarding JSTOR, please contact support@jstor.org.

278 m μ , with shoulders at 284 and 290 m μ . There is a suggestion of a component at 260 m μ . The visible and near-infrared spectra show no peaks from 340 m μ to 1000 m μ . The optical density at 278 m μ follows Beer's law (Fig. 1) throughout the concentration range tested. The absorption coefficient $E^{1\%}_{1\text{cm}}$ is 11.4. The absorption spectrum of a sample of mucoprotein prepared according to the method of Tamm and Horsfall is found to be identical with this.

MYLES MAXFIELD

Brookhaven National Laboratory,
Upton, New York

References and Notes

1. I. Tamm and F. L. Horsfall, Jr., *Proc. Soc. Exptl. Biol. Med.* 74, 108 (1950).
2. ———, *J. Exptl. Med.* 95, 71 (1952).
3. I. Tamm, J. C. Bugher, F. L. Horsfall, Jr., "Ultracentrifuge studies of a urinary mucoprotein which reacts with various viruses," *J. Biol. Chem.* 212, 125 (1955).
4. N. Di Ferrante and E. A. Popenoe, personal communication.
5. This research was carried out at Brookhaven National Laboratory under the auspices of the U.S. Atomic Energy Commission.
6. P. Doty and R. F. Steiner, *J. Chem. Phys.* 20, 85 (1952).

9 July 1958

Artificially Induced Circulation of Lakes by means of Compressed Air

Abstract. Turbulence induced by air bubbles causes circulation in small thermally stratified lakes. Tests were made under summer and winter (ice-cover) conditions. Homiothermal conditions, isometric concentrations of phosphorus, and increases of dissolved oxygen were achieved, at various rates of treatment. The application of the technique for lake management and in studies of lake dynamics is suggested.

Stratified lakes in the Temperate Zone present certain problems. (i) They accumulate astonishing amounts of phosphorus in their lower regions. At the same time they exhibit a dearth of this element in the euphotic zone (1). (ii) In some there is no vernal circulation, as there is in typical dimictic lakes. (iii) In the winter some tend to have serious oxygen deficits under the ice cover, often resulting in the winterkill of fish fauna. These problems appear to be rectifiable by some means of induced circulation (2-4). The actual circulation of lake basins with water pumps has been demonstrated (3), and other techniques, such as the use of the turbulent effect of compressed air, offer promise.

Compressed air is used in natural waters, chiefly for reoxygenation (5) or to remove the ice from water surfaces (6). It was the purpose of the study described in this report to test the effect of air-induced circulation in stratified lakes.

In tests under summer conditions, compressed air was used to bring hypolimnetic water up into the euphotic zone. A small experimental lake, Sawmill Pond, with a maximum depth of 7.1 m and an area of 1250 m² was used. Air was delivered through small perforations spaced along the length of an air conductor, suspended just above the bottom. The daily rate of flow was 101 lit. (1 atm, 20°C) per cubic meter of lake volume. The effect was immediate and pronounced. An almost homiothermal condition was observed after 4½ hours of treatment (Fig. 1). The concentrations of soluble phosphorus became isometric with depth. Prior to treatment they exhibited the typical high concentrations in the 2- to 3-m zone. It was observed that the absolute content of the total phosphorus in the upper 2 m was higher in every case than the mean of the pretreatment values.

In an experiment conducted in Tub Lake (0.7 hectare) in which lower daily rates of treatment (5.6 lit. of air per cubic meter of lake volume) were used, it was shown that radioactive phosphorus which had previously been placed in the hypolimnion could be brought to the surface (7). In this case the thermocline was lowered, but it retained its identity.

The amount of work theoretically required to compress the air to the necessary hydrostatic pressure (and hence to expand the rising bubble) was compared with the change in volume of the epilimnion resulting from the treatment. This was done in order to provide a basis for comparison of treatments in lakes of different sizes. The values obtained ranged from 8.17 × 10² g cm to 19.4 × 10² g cm for the work applied to each cubic meter of lake volume for each

cubic meter of increase of the volume of the epilimnion.

Tests under conditions of ice cover were conducted with essentially the same physical installation. Daily additions of 3.4 and 1.9 lit. of air per cubic meter of lake volume were applied in two consecutive years on Katharine Lake (6.1 hectares). These applications maintained areas of open water continuously and concentrations of dissolved oxygen at about 7 and 2 parts per million, respectively. It should be emphasized that, under normal conditions, levels of oxygen concentration in this water are less than 3 parts per million and are periodically less than 1 part per million. It was noted that average water temperatures were reduced to as low as 0.7°C at the higher rate of treatment.

The force of the wind, exerted on the surface of a stratified lake, has a relatively small effect. An example of this is presented by Hutchinson (8) for Linsley Pond, where the thermocline of the lake was little affected by the hurricane of September 1938. By contrast, controllable forces, when applied in the manner described in this report, act from within the basin with, figuratively speaking, tornadic effect.

It is suggested that for the experimental limnologist the "air-lift" procedure can serve as a tool in the study of lake dynamics. He can achieve homiothermal or isochemical conditions down to any contour level or can establish a thermocline in a desired position.

The technique affords a means of "intrafertilization" under certain conditions. Whether or not this effect is translatable into sufficiently large amounts of desirable end products—that is, increased zooplankton or fish production—cannot be

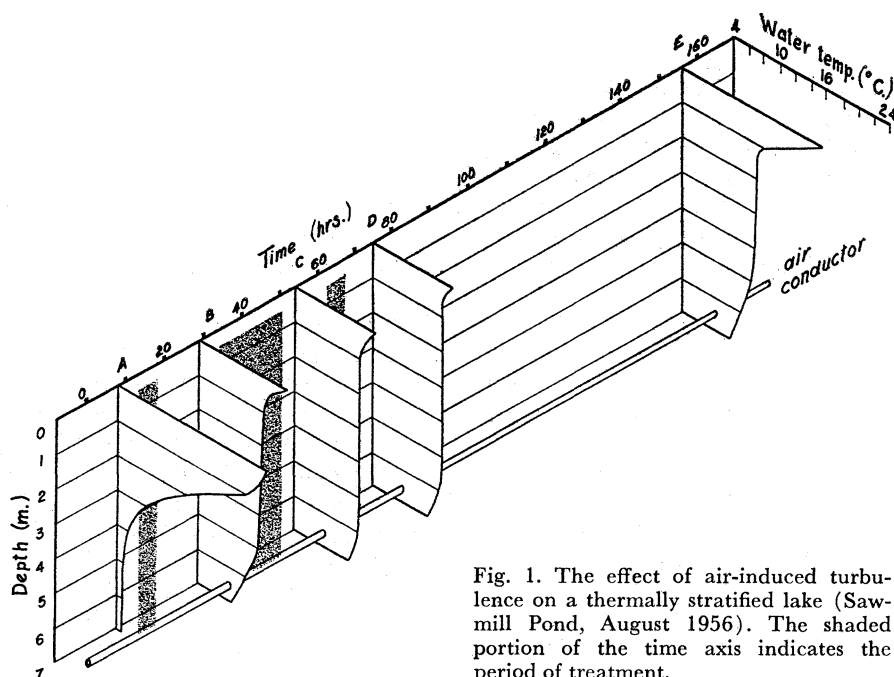

Fig. 1. The effect of air-induced turbulence on a thermally stratified lake (Sawmill Pond, August 1956). The shaded portion of the time axis indicates the period of treatment.

ascertained from these experiments. However, artificial circulation offers other possibilities for the management of lakes. One possibility is the assurance of the vernal circulation of "spring meromictic" lakes, in which trout could not ordinarily be held during the summer period.

This technique can be used to prevent winterkill in ice-covered lakes. However, many details, particularly with reference to the effect of low water-temperatures on the fauna, remain to be examined (9).

WILLIAM R. SCHMITZ
ARTHUR D. HASLER

Department of Zoology,
University of Wisconsin, Madison

References and Notes

1. A. D. Hasler, *Proc. UNESCO Intern. Conf. Radioisotopes Sci. Research Paris* (1957), vol. 4.
2. E. A. Thomas, *Schweiz. Fischerei Z.* 7-8, 1 (1944).
3. J. Grim, *Allgem. Fischerei Z.* 1952, 281 (July 1952); F. F. Hooper, R. C. Ball, H. A. Tanner, *Trans. Am. Fisheries Soc.* 82, 222 (1953).
4. C. Caille, *Verhandl. intern. Ver. theoretische und angew. Limnologie* 10, 104 (1949).
5. H. Wagner, *Bes. Mitt. Deutsch. Gewässerk. Jahrb.* 15, 1 (1956).
6. J. Hemphill, *Fisheries Div. Arizona Game and Fish Dept. Rept.* (1954).
7. M. C. Sparr, thesis, University of Wisconsin (1958).
8. G. E. Hutchinson, *A Treatise on Limnology* (Wiley, New York, 1957), vol. I.
9. This work was jointly financed by the U.S. Atomic Energy Commission (under contract AT 11-1-64, project No. 12), Dr. and Mrs. L. E. Frankenthal, Jr., the Ben S. McGiveran Foundation, and the Wisconsin Conservation Department.

14 August 1958

Thermocouple for Vapor Pressure Measurement in Biological and Soil Systems at High Humidity

All biological systems depend upon water regimes that are often delicately balanced with respect to the physical condition of the water. Water binding is determined by forces associated with bodies ranging upward in size from individual solute molecules, through colloidal particles, and on up to the larger solid surfaces bounding the system. The effect of binding energy on biological activity is expressible in terms of a colligative property of the water, such as vapor pressure. In addition, the effect of binding-energy gradients on the movement of water in biological systems is of immediate interest.

For example, the uptake of water by plant roots is restrained by forces associated with solute particles in the soil solution and also by forces based in the soil matrix which hold the water films on the soil surface. Both of these binding actions depress the vapor pressure of water in soil, and it has long been supposed that a measurement of this vapor pressure would give a good index of the suction that must be developed in the plant root to effect water intake. Unfortun-

ately, the range of relative humidity of soil air that has agricultural significance lies above 99 percent and presents considerable difficulty with respect to measurement. Wet-junction thermocouples with adequate sensitivity (1) have been available, but problems connected with calibration and sample handling were not solved. The thermocouple-sample arrangement shown in Fig. 1 has evolved from tests of various designs and now makes possible precise relative-pressure measurements near saturation for a variety of sample materials. The method is based on the temperature difference between dry and wet junctions in the sample chamber. The dry junction follows ambient temperature, and the wet junction, through evaporation effects, responds to ambient vapor pressure.

In Fig. 1, *A* is the assembly as installed in the thermostat, and *B* is an enlarged view of the thermocouple. The insulating cover (1) helps to maintain the samples at constant temperature in the liquid bath (2). The masonite cover (3) supports a number of thin-walled brass test tubes (4). The thermocouple mount guides the couple into the sample container and makes it convenient to shift the couple from one sample to another. The mount consists of a cylinder of thin-walled brass (5) closed at the lower end with a disc of copper (8) and a copper tube (7) assembled with soft solder. The handle (6) is made of rigid plastic. The lead wires (11), have seven strands of 36-gage bare copper and have vinyl insulation of 0.1 cm outside diameter. The two lead wires make a tight fit in tube (7). The twisted strands extend a short distance (12) below the vinyl and are reduced to a single strand for an additional distance (13). Soft solder with low thermal electromotive force is used to join bare Chromel P (14) and Constantan (15) wire, 25 μ in diameter, and to attach the silver cylinder (16), which is of 0.185 cm outside diameter, with a wall 0.018 cm thick and 0.051 cm high. The thermocouple resistance is 20 ohms. A standard-size water droplet is obtained in the silver cylinder by submerging the cylinder in water and then rapidly lowering the vessel containing the water.

Sample containers are made of brass tubing (17) with end caps (18) of brass or plastic. The caps have a square shoulder and are prepared for use by dipping in hot universal wax. The fillet of wax thus left in the shoulder recess provides a vapor seal. Soil samples are prepared by filling the sample container with a closely fitting soil core and closing the ends with solid caps. Later, an end cap with a 0.9-cm hole is attached, and the container is supported upside down in a jig, while a central hole in the soil core is scratched out by a thin rotating tool. A cap (19) with a 0.6-cm hole is then attached, and the sample is inserted in

the bath. Figure 1*A* shows a soil sample with the thermocouple in place. Vapor measurements of plant leaves are made by lining the sample chamber with leaf tissue. Measurements of aqueous solutions are made by supporting the solution on a filter-paper liner, including a paper annulus at the top of the chamber.

After placement in the bath, the vapor seal for the sample is accomplished by means of a water bag made from a rubber finger cot and supported on a plastic mount similar to the metal mount for the thermocouple. The measurement is made by inserting the thermocouple in the sample container. A steady electrical reading is usually obtained in from 10 to 30 minutes if the vapor condition of the sample is steady. A longer time is required at higher relative pressures. The thermocouple output is measured to an accuracy of 0.01 μ v by means of the potentiometer arrangement described by Teele and Schuhmann (2). Precautions given by these authors for avoiding extraneous electromotive forces should be closely observed. Measurements thus far have been made at 25°C, with temperature fluctuations in the bath kept at less than $\pm 5 \times 10^{-4}$ °C.

The thermocouples were calibrated at five points, each point being the vapor pressure of KCl at known osmotic pressure in the range from 5 to 65 bars. Values of osmotic pressure at 25°C for the standard solutions used in the calibration described above were obtained by use of the factor 13.33 bars of osmotic pressure per degree centigrade of freezing-point depression. The electrical output of the couples was proportional to the osmotic pressure. Sensitivities of the four couples expressed as microvolts per

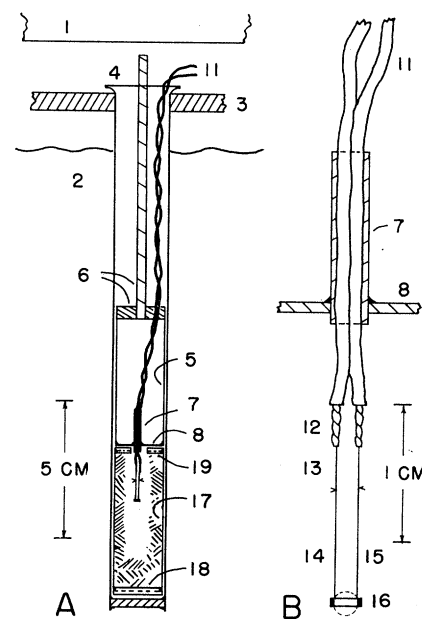

Fig. 1. Thermocouple and sample chamber for measuring vapor pressure.