

Effects of Suspended Particles on Net-Tending Behaviors for *Hydropsyche sparna* (Trichoptera: Hydropsychidae) and Related Species

J. M. RUNDE AND R. A. HELLENTHAL

Department of Biological Sciences, University of Notre Dame, Notre Dame, IN 46556-0369

Ann. Entomol. Soc. Am. 93(3): 678-683 (2000)

ABSTRACT Laboratory experiments using small artificial streams were performed on 3rd-5th instars of the net-spinning caddisflies *Hydropsyche sparna* (Ross), *H. betteni* Ross, *H. morosa* (Hagen), and *H. slossonae* (Banks) to examine the effects of suspended particle transport on their behavior, drift, and mortality. Larvae were exposed to suspended particles 0.4–500 μm in diameter at suspended concentrations between 667 and 6000 mg/liter for 24 h. Water velocity was held constant at 23 cm/s in all experiments to eliminate the confounding effects of flow on net-tending. Drift and mortality rates were also measured but did not occur in the experimental or control populations. Four net-tending behaviors occurred that varied in the degree of filter net modification. One behavior was to clean the net of particles and leave it intact. Three other behaviors, involving modification of the filter net strands, were detachment of one side, cutting a hole in the middle of the filtering surface, and total removal of the net. For particles $>64 \mu\text{m}$ in diameter, the frequency of net modification increased with increased particle size and load. Intraspecific differences in net-tending behaviors occurred in only 1 instance, and there were no interspecific differences. We speculate that *H. sparna* individuals modify their nets to change the local hydrology and therefore prevent excessive fine particle transport into their retreats. Observed net-tending behaviors might represent adaptations to frequent exposures to suspended sediment transport. Fine suspended particle transport of the duration and magnitude studied represents a sublethal disturbance to hydropsychids.

KEY WORDS *Hydropsyche sparna*, suspended sediment, sediment transport, stream

FINE SEDIMENT TRANSPORT (suspended and bedload) is the predominant cause of stream degradation in North America (Waters 1995). Suspended sediment transport is the 7th ranked pollutant to streams (EPA 1990). Other pollutants, such as pesticides, nutrients, and metals may be adsorbed to suspended sediment, thereby increasing potential detrimental effects. Newcombe and MacDonald (1991), in an examination of 13 field studies, categorized all suspended sediment effects as lethal to stream insects, resulting in reductions in densities ($\#/m^2$) from 40 to 94%. However, drawing general conclusions from field studies is difficult because of the confounding effects of particle size, type, load, and water velocity and because many studies do not separate the effects of the particles in suspension from those deposited (Ward 1992). Waters (1995) reviewed sediment effects on stream insects and fisheries and concluded that the short-term direct effects of suspended sediment have no significant influence on the stream benthos.

Filter-feeding taxa in streams are particularly susceptible to suspended sediment exposure (Hynes 1973). Three aquatic orders comprise the majority of the filter-feeding larval insects in streams: Ephemeroptera, Diptera, and Trichoptera (Wallace and Merritt 1980). Within the Trichoptera, 3 filter-feeding families use silken nets: Philopotamidae, Polycentropodidae,

and Hydropsychidae. The hydropsychids are numerically the most predominant stream insect (Roback 1962). Net-mesh size is an attribute that characterizes hydropsychid nets and is highly correlated to the observed distributions of the organisms (Sattler 1963, Kaiser 1965, Williams and Hynes 1973, Malas and Wallace 1977, Alstad 1980, Georgian and Wallace 1981).

Impacts of suspended sediment on net spinners include net clogging, ripping, or burying by sediment and can result in decreased food acquisition (Strand and Merritt 1997), interference with respiration (Lemley 1982), increased energy expenditure because of net cleaning, increased time spent on net cleaning (Tachet et al. 1986), or decreased fitness in the affected organisms (Wallace and Malas 1976). Tachet et al. (1986) proposed that suspended sediment transport results in the exclusion of certain species from a habitat because of increased energetic requirements for net cleaning.

Strand and Merritt (1997) evaluated the growth and survival of *Hydropsyche sparna* (Ross) and *H. betteni* Ross larvae in the laboratory after brief exposure to moderately increased sediment levels. Short-term growth did not change significantly for either species, but slight gains by *H. sparna* and slight losses by *H. betteni* produced significant differences between species. Larval survival decreased for each species be-

cause of deposition of the suspended sediment. However, the authors advise caution in applying their survival results to natural populations because of the possibility of behavioral avoidance of sediment.

Newcombe and MacDonald (1991) grouped the effects of suspended sediment exposure into 3 categories based on severity: lethal, sublethal, and behavioral. Lethal effects kill individuals, sublethal effects change the tissues or physiology of the organisms, and behavioral effects alter activity patterns, or the kinds of activities, from behaviors shown in an undisturbed environment. Variables that modify the impact of suspended sediment include the concentration, duration, and frequency of exposure, ambient water quality, sensitivity of the species, and the life history stage affected. Culp et al. (1986) manipulated sediment levels in streams and demonstrated differences in the drift response of benthic invertebrates, depending on the microhabitat occupied. Individuals located on the top surfaces of the stream bottom drifted first. Gore et al. (1990) discussed the need for future research examining the relative susceptibility of each life stage to disturbance for the purposes of prediction and mitigation of adverse effects.

We designed a research program using a series of laboratory experiments to evaluate the relative importance of both abiotic (particle size and load) and biotic (behavior, instar, and species) factors. The goals of this study were to examine the short-term effects of suspended particles on 3rd–5th instars of the net-spinning caddisflies *H. sparna*, *H. betteni*, *H. morosa* (Hagen), and *H. slossonae* (Banks). We held water velocity constant to eliminate flow and scour (physical removal via abrasion) as confounding factors. We used both inorganic (clay, coal, and Plexiglas) and organic (ground leaves) particles. Drift and mortality rates were measured as an indication of the disturbance potential of suspended particles. Objectives of this study were to determine the effects of particle size and load on net-tending, drift, and mortality of hydropsychids; to test for intra- and interspecific differences in these responses; and to determine whether there is a particle size, or concentration, that elicits increased rates of drift, mortality, or net-tending behavior.

Materials and Methods

Experimental Conditions. Experimental chambers (artificial streams) consisted of 3 pieces: a flat bottom Plexiglas plate, a clear outer polyvinyl chloride (PVC) tube, and an inner PVC tube (Fig. 1). The artificial stream volume was 150 ml with a bottom surface area of 61.65 cm². Water was recirculated using paddle wheels powered by a variable speed drill. Eighteen artificial streams were used simultaneously. Each stream had a single rod with 1 paddle wheel. The experiments were conducted in a cold room using a photoperiod of 12:12 (L:D) h at a temperature of 16 ± 1°C. Larvae were fed daily with ground flake fish food (20 mg per stream).

Hydropsychids (*H. sparna*, *H. betteni*, *H. morosa*, and *H. slossonae*) were collected during February 1997

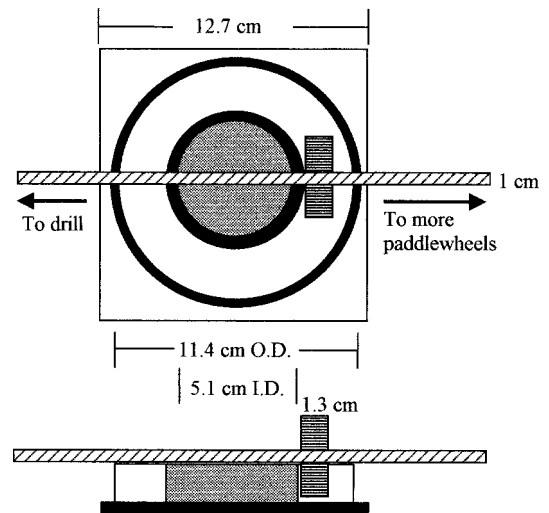

Fig. 1. Schematic of the experimental artificial streams used. Dark circles represent the inner and outer tubes. The portion of the artificial stream inside the inner circle is not part of the living space for the organisms. Water is moved clockwise using a paddlewheel attached to a rod running across the top of the artificial stream.

from Juday Creek, St. Joseph County, IN. To minimize injury from excessive handling, individuals were identified to species and instar after the completion of each experiment. Initially, the insects were sorted into 3 groups based on body size, approximating 3rd–5th instars. Ten individuals of each size were added to every artificial stream. Each artificial stream served as a replicate. For each replicate, drift and mortality were calculated as the proportion of each instar abandoning their retreat, or dying, within 24 h. Four net-tending behaviors were observed: cleaning without cutting net fibers, detaching fibers from their attachment points along one side of the net, cutting fibers in the center of the net to form a hole, and totally removing the net. Net manipulation is the percent of each instar, in each replicate, modifying the net fibers after 24 h. Voucher specimens are housed in our laboratory.

All experiments were conducted at 23 cm/s to eliminate flow and scour as confounding factors. To adequately test the effect of particle size, 4 particle types were used ranging in diameter from 0.4 to 500 µm. Sand particles between 64 and 500 µm do not stay suspended at 23 cm/s; therefore, we substituted ground leaves and Plexiglas particles to simulate the particle size effect of sand. Plexiglas particles had the advantage of staying suspended for the entire length of the treatment period. Ground leaf particles stayed suspended for several hours and could be ground into several size classes.

The effect of particle size and concentration on insect behavior, drift, and mortality was tested using the following 3 experiments: (1) individual applications of clay, coal, or Plexiglas particles; (2) sequential applications of clay, coal, and Plexiglas particles; and

(3) individual applications of ground leaf particles. Insects were added to the artificial streams and allowed 24 h to construct a retreat (using sand particles >2 mm in diameter) and a filter net. Individual retreat per net positions were mapped and particles applied. After 24 h, drift (number not present in its retreat), mortality (number dead), and net-tending behaviors were measured. The conditions of the nets were observed by putting each artificial stream under a dissecting microscope. Insects were reused only in the sequential application experiment.

Each particle type was dry sieved (1 h) through sieves with 63-, 125-, 250-, 500-, and 1,000- μm mesh sizes. Clay particles ($\approx 0.4 \mu\text{m}$ suspended) were applied at 0.5 g per artificial stream (81.1 g/m^2 , 3,333 mg/liter). The clay particles produced turbid water for up to 2 h, eventually electrostatically coating every surface in the artificial stream, including the nets. Coal particles (<63 μm) also were applied at 0.5 g per artificial stream. These particles produced turbid water for up to 1 h. The coal particles did not adhere to net fibers and fell off when the water velocity was reduced to zero. Plexiglas particles (250–500 μm) were applied at 1.0 g per artificial stream (162 g/m^2 , 6,667 mg/liter). The Plexiglas stayed suspended for >24 h. Whole leaves (*Prunus serotina* J.F. Ehrhart) were gathered on the stream banks of Juday Creek in February 1997 after being naturally leached of nutrients from several months of exposure to the elements. The leaves were ground into diameters of 63–125, 126–250, and 251–500 μm and then applied at levels of 0.1 g (16.2 g/m^2 , 667 mg/liter), 0.3 g (48.6 g/m^2 , 2,000 mg/liter), 0.5 g (81.1 g/m^2 , 3,333 mg/liter), 0.7 g (113.5 g/m^2 , 4,667 mg/liter), and 0.9 g (146 g/m^2 , 6,000 mg/liter). The leaf particles stayed suspended for 1–4 h, depending on the particle size. In the sequential application experiment, clay particles were added on the 1st treatment day, followed 24 h later by coal particles, and then 24 h later by Plexiglas particles. Examination of the nets and enumeration of drift and mortality was done 24 h after each particle addition. One replicate for each combination of particle type, concentration, and species was video taped for visual analysis of water and particle flow patterns near the net-retreat complex.

Larvae of *H. betteni*, *H. morosa*, and *H. slossonae* were tested with a single 0.9-g application of leaf particles in the 3 size classes between 64 and 500 μm . Because individuals of these species were not collected in sufficient numbers, replicated experiments were not possible. Therefore, drift, mortality, and behavior values were calculated as a proportion after pooling all individuals in all artificial streams.

Statistical Analysis. Because there was no variation in the controls, all tests compare populations within the treatments only. A Kruskal–Wallis one-way analysis of variance (ANOVA) test was used to determine the presence of net-modifying behaviors between instars in the single Plexiglas addition experiment (SigmaStat 1997). In the combination coal, clay, and Plexiglas experiments, the Friedman repeated-measures ANOVA was used to test for the presence of either net

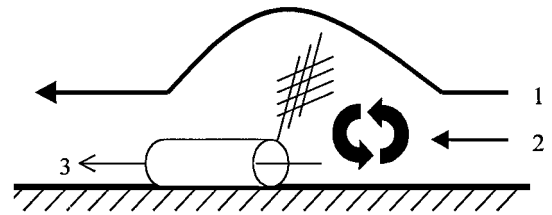

Fig. 2. Schematic of the hydrodynamics associated with suspended particles approaching a clogged hydropsychid net. Lines 1–3 show the path a suspended particle follows when passing a hydropsychid net (cross hatching) and retreat (tube). Some water is diverted around the net because of net clogging. Particles not diverted follow line 2 and enter an eddy immediately upstream of the net. These particles are either filtered by the net, flow into the retreat (line 3), or are carried downstream (line 1).

cleaning alone or net-modifying behaviors (SigmaStat 1997). Two-way ANOVA was used to test for differences in net-modifying behaviors among instars and particle loads in the ground leaf experiments.

Results

Hydrology. Flow patterns and sediment particle paths were examined through analysis of video tapes. There were 3 possible paths for water flow near the net per retreat complex: around the net, through the net, and through the retreat itself (Fig. 2). Larger particles (Plexiglas and leaves) clogged the filter nets to varying degrees and forced particles into the retreat, where they were deposited. The insects made repeated unsuccessful attempts at cleaning clogged nets and retreats of particles. Eventually they modified the nets, creating bypass routes for the suspended particles. The reduced particle load allowed for the removal of particles deposited in the retreat and partial cleaning of the filter net.

Net-tending Behaviors for *H. sparna*. Clay particles adhered to net fibers, but did not clog the nets or deposit in the retreats. At initial particle concentrations, the insects remained in their retreats and did not attempt net cleaning. All nets were cleaned 7–8 h after

Table 1. Behavioral responses of *H. sparna* after sequential applications of coal, clay, and Plexiglas particles

Particle type	Behavior, %		
	3rd n = 6	4th n = 18	5th n = 2
Coal			
Clean net behavior	100	100	100
Clay			
Clean net behavior	100	100	100
Plexiglas			
Cut hole behavior	67	47	50
Remove net behavior	33	53	50

Behaviors varied in degree of net modification, from no modification (clean net only), to partial modification (cut a hole in filtering surface), to total net removal (cut down).

particle introduction (Table 1). Drift and mortality did not increase after exposure to clay particles.

Coal particles covered net fibers, but did not clog the nets or deposit in the retreats. The insects remained in their retreats at initial particle concentrations and did not attempt net cleaning. All nets were cleaned within 5 h after particle introduction (Table 1). Drift and mortality did not increase after exposure to coal particles.

Plexiglas particles clogged nets within 30 s, which diverted more particles toward the retreat where they were deposited. Insects repeatedly cleared the retreat entrances and then attempted to clean the nets, but failed because of the continued high particle concentrations and rapid clogging rates. All individuals of 3rd and 4th instars modified their nets within 24 h ($n = 5$ and 33, respectively). Fifth instars modified their nets 87.5% of the time ($n = 8$). Net modifications allowed suspended particles to bypass the retreat entrance. These behaviors suggest that maintaining a clear retreat entrance is more important than maintaining a clean net-filtering surface. No drift or mortality occurred, indicating that exposure to these particles did not constitute an immediate disturbance. Individuals in the control artificial streams never modified their nets. No intraspecific differences in net-tending behaviors existed (Kruskal-Wallis one-way ANOVA on ranks; $n = 5, 33,$ and 8 for 3rd, 4th, and 5th instars, $H_2 = 4.75, P = 0.093$).

Sequential applications of clay, coal, and Plexiglas yielded the same results as application of each particle type individually (Table 1). Net-modifying behavior increased with increasing particle size for 3rd and 4th instars (3rd instars, Friedman repeated measures ANOVA on ranks, $n = 6, (22 = 12.0, P = 0.008$; instar IV, $n = 18, (22 = 36.0, P < 0.001)$). Fifth instars showed a similar trend, but the result was not significant because of the low number of replicates ($n = 2, \chi^2_2 = 4.0, P = 0.5$).

Leaf particles clogged the nets, deposited in the retreat entrances, and caused net modification behaviors. The degree of modification depended on the particle size and load (Fig. 3). No drift or mortality occurred in these experiments. Net-modifying behaviors increased with increasing load for particle sizes 64–125 μm (two-way ANOVA, load, $F = 4.8$; $df = 4, 30; P = 0.004$; instar, $F = 1.7$; $df = 2, 30; P = 0.21$; interaction, $F = 0.31$; $df = 8, 30; P = 0.96$). Significant differences occurred only between loading rates of 0.1 and 0.9 g (Tukey posthoc test). Net-modifying behaviors also increased with increasing particle load for particle sizes 126–250 μm (two-way ANOVA, load $F = 5.36$; $df = 4, 30; P = 0.01$; instar, $F = 58.9$; $df = 4, 30; P < 0.001$; interaction, $F = 2.5$; $df = 8, 30; P = 0.033$). The Tukey test indicated that 3rd instar differed from 4th and 5th instars. The significant interaction term makes interpretation of the main effects difficult. Therefore, individual one-way ANOVAs were used to test for effects by individual instars. The behavioral responses for instars showed significant differences according to loading rate (3rd instar, $F = 20.9$; $df = 4, 10; P < 0.001$; 4th instar, $F = 26.8$; $df = 4, 10; P < 0.001$;

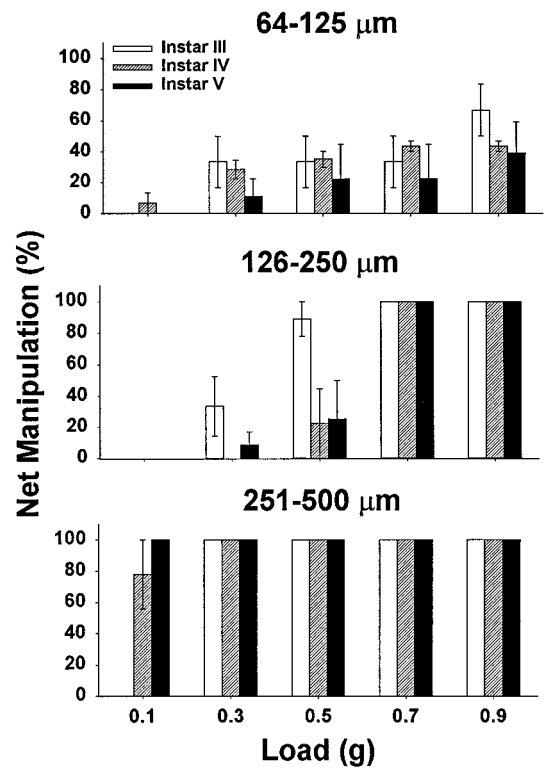

Fig. 3. Occurrence of net manipulations (mean \pm 1 SE) after exposure to leaf particles between 64 and 500 (μm in diameter) at loads between 0.1 and 0.9 g. Leaves were applied in 0.1-g increments every 24 h.

5th instar, $F = 17.7$; $df = 4, 10; P < 0.001$). Tukey tests are summarized in Table 2.

Net-modifying behaviors increased with increasing particle load for particle sizes 251–500 μm (two-way ANOVA, $n = 3,$ load, $F = 30.2$; $df = 4, 30; P < 0.001$; instar, $F = 16.73$; $df = 2, 30; P < 0.001$; interaction, $F = 16.73$; $df = 8, 30; P < 0.001$) also. However, differences in behaviors for this particle size were the result of a lack of penetration by the larger particles into the microhabitats of 3rd and 4th instars (experimental artifact), rather than behavioral differences.

Net-tending Behaviors for *H. betteni*, *H. morosa*, and *H. slossonae*. When exposed to suspended leaf particles, these insects exhibited 3 behaviors: no net modification, net removal, or creating a hole in the filtering surface of the net (Table 3). The increase in net modification with increasing particle size ob-

Table 2. Results of pairwise Tukey post hoc test for leaf experiments on *H. sparna* at particle sizes 126–250 μm

Load, g	0.1	0.3	0.5	0.7	0.9
0.1	—				
0.3		—			
0.5	3rd	3rd	—		
0.7	3rd, 4th, 5th	3rd, 4th, 5th	4th, 5th	—	
0.9	3rd, 4th, 5th	3rd, 4th, 5th	4th, 5th		—

Table 3. Behavioral responses by *Hydropsyche* species to leaf particles, 64–500 μm in diameter, at loads of 0.9 g

Species	Behavior	Particle size, μm					
		64–125		126–250		251–500	
		%	n	%	n	%	n
<i>H. betteni</i>	Hole	15.5	13	66.7	12	87.5	8
	No net	15.4	13	16.7	12	0	8
	No change	69.2	13	16.7	12	12.5	8
<i>H. morosa</i>	Hole	9.0	11	100	8	58.3	12
	No net	45.5	11	0	8	33.3	12
	No change	45.5	11	0	8	8.3	12
<i>H. slossonae</i>	Hole	50.0	4	71.4	7	66.7	3
	No net	25.0	4	28.6	7	33.3	3
	No change	25.0	4	0	7	0	3

Results are percent occurrence, pooled across instar and replicate.

served for *H. sparna* also occurred for these congeners. A threshold occurred in net modifications for particles larger than 125 μm in diameter.

Discussion

The goal of this study was to evaluate the effects of sediment particle size and load on net-tending behaviors, drift, and mortality for larvae of *H. sparna*, *H. betteni*, *H. morosa*, and *H. slossonae*. Our overall research program, of which these experiments were one part, was designed to independently study variables affecting the biotic responses to suspended sediment transport. In this study, we eliminated the effects of scour and velocity. Ideally, we would have preferred to use inorganic sediments exclusively in these experiments; however, water velocity was kept below the magnitude required to keep sand particles suspended. We believe Plexiglas and ground leaf particles provided a reasonable representation of the particle size effects (net and retreat clogging) of sand particles. Additionally, leaf particles are a normal component of the detritus found in most streams and, therefore, a component of the suspended particles in transport.

Our results suggest that short-term exposures to suspended particles do not constitute an immediate lethal disturbance (i.e., drift or mortality) for *H. sparna*. This is in agreement with Waters' (1995) summary of suspended sediment effects on benthic invertebrates, although he also stated that little is known of suspended sediment effects on stream invertebrates. However, these results do show behavioral and, perhaps, sublethal effects (Newcombe and MacDonald 1991) on *H. sparna* that could decrease survival at longer time scales. The important variables affecting these behavioral responses, in order of relative importance, are velocity, net mesh size, particle size, and sediment concentration (Runde 1999). Net mesh size (as represented by instar) and particle size are equally important because as the filter mesh and particle sizes converge, behavioral modifications of the nets occur (Fig. 3). Below the convergence point, particles (clay and coal) were too small to clog the nets so the insects respond with a wait-and-clean behavior. Above the convergence point, varying degrees of net modification begin, depending on the severity of the clogging

of the retreat entrance. The convergence point is a threshold physical event resulting in a changed biotic response.

Net-modifying behaviors in response to suspended particles might be widespread among trichopteran filter-feeders that use capture nets. A polycentropodid, *Neureclipsis* sp., creates holes in its net when exposed to clay particles at 3,333 mg/liter (J.M.R. and M.-J. Szczerba, unpublished data). The *Neureclipsis* sp. experiments used the same artificial streams and methods described for this study. In contrast to *H. sparna*, *Neureclipsis* sp. uses a cornucopia shaped net to capture whole animals. Nevertheless, as with *H. sparna*, *Neureclipsis* modifies its net to change local hydrology and prevent particle deposition in the net, where the organism rests. Alternately, although the net mesh clogs, the hole increases the proportion of the approaching flow that enters the net entrance and, thereby, enables the capture of animals.

Instar-specific differential effects on benthic invertebrates have been proposed by Rosenberg and Wiens (1978), Gore et al. (1990), and Schlosser (1990). Our research did not demonstrate convincing differences in net-tending behaviors between instars (Fig. 3). When differences existed, 3rd instars were more greatly affected, whereas 4th and 5th instars were affected similarly or to a lesser degree.

Tachet et al. (1986) proposed species elimination of co-occurring hydropsychids based on the energetic requirements of declogging nets. Our research suggests that, at least in the short term, this would not occur because the importance placed on maintaining adequate flow through the retreat. Rather than continuously cleaning the net to keep their retreats clear of particles, hydropsychids sacrificed the ability to filter feed. For longer term exposures, hydropsychids could relocate to a microhabitat with favorable spatial and velocity conditions to reduce particle exposure. This would involve behavioral drift or relocation on the same rock. The potential exists for interspecific differences in drift and, therefore, species elimination if the net mesh sizes of the species were sufficiently different. However, we propose that the underlying reason for behavioral drift is not differential energy expenditure on net cleaning, but a determination by individuals that the sediment condition does not favor

maintenance of adequate flow through the retreat. The presence of the net manipulation behaviors might be an evolutionary response to frequent exposures to suspended sediment (Resh et al. 1988, Poff 1992, Ward 1992, and Waters 1995).

In summary, knowledge of the spatial and velocity microhabitats of the population, net mesh sizes, particle diameters and loads, and durations of exposure would aid in the prediction of suspended sediment effects. The presence of a small amount of large-sized particles in the suspended sediment load might skew behaviors toward net manipulation because once clogging begins it can progress rapidly, even with a large proportion of smaller particles. Filter-feeding activities are curtailed under suspended particle conditions that clogged retreats. The presence of filter-net modifications was a function of suspended particle size and load. Large particles clog nets and subsequently deposit in retreat entrances. No intra- or interspecific differences occurred in net-tending behaviors. Net modifications might represent adaptations to frequent exposures to suspended sediment transport.

Acknowledgments

We thank Noah W. Gray for providing valuable assistance in completion of these experiments and The University of Notre Dame Environmental Research Center for funding this project.

References Cited

- Alstad, D. N. 1980. Comparative biology of the common Utah Hydropsychidae (Trichoptera). *Am. Midl. Nat.* 103: 167–174.
- Culp, J. M., F. J. Wrona, and R. W. Davies. 1986. Response of stream benthos and drift to fine sediment deposition versus transport. *Can. J. Zool.* 64: 1345–1351.
- Georgian, T. J., and J. B. Wallace. 1981. A model of seston capture by net-spinning caddisflies. *Oikos* 36: 147–157.
- Gore, J. A., J. R. Kelly, and J. D. Yount. 1990. Application of ecological theory to determining recovery potential of disturbed lotic ecosystems: research needs and priorities. *Environ. Manag.* 14: 755–762.
- Hynes, H.B.N. 1973. The effects of sediment on the biota in running water, pp. 653–663. In *Proceedings of Hydrology Symposium*, University of Alberta, Edmonton, Canada. Department of the Environment, Ottawa, Canada.
- Kaiser, P. 1965. Über Netzbau und Stromungssinn bei den Larven der Gattung *Hydropsyche* Pict. *Int. Rev. Ges. Hydrobiol.* 50: 169–224.
- Lemley, D. A. 1982. Modification of benthic insect communities in polluted streams: combined effects of sedimentation and nutrient enrichment. *Hydrobiologia* 87: 229–245.
- Malas, D., and J. B. Wallace. 1977. Strategies for coexistence in three species of net-spinning caddisflies (Trichoptera) in second-order southern Appalachian streams. *Can. J. Zool.* 55: 1829–1840.
- Newcombe, C. P., and D. D. MacDonald. 1991. Effects of suspended sediments on aquatic ecosystems. *N. Am. J. Fish. Manag.* 11: 72–82.
- Poff, N. L. 1992. Why disturbances can be predictable: a perspective on the definition of disturbance in streams. *J. N. Am. Benthol. Soc.* 11: 86–92.
- Resh, V. H., A. V. Brown, A. P. Covich, M. E. Gurtz, H. W. Li, G. W. Minshall, S. R. Reice, A. L. Sheldon, J. B. Wallace, and R. C. Wissmar. 1988. The role of disturbance in stream ecology. *J. N. Am. Benthol. Soc.* 7: 433–455.
- Roback, S. S. 1962. Environmental requirements of Trichoptera, pp. 118–26. In C. M. Tarzwell [ed.], *Seminar in biological problems in water pollution*, 3rd ed. USPHS Publ. 999-WP-25.
- Rosenberg, D. M., and A. P. Wiens. 1978. Effects of sediment addition on macrobenthic invertebrates in a northern Canadian river. *Water Res.* 12: 753–763.
- Runde, J. M. 1999. Hydrodynamic and behavioral responses to sediment transport by *Hydropsyche sparna* (Trichoptera: Hydropsychidae). Ph.D. dissertation, University of Notre Dame, Notre Dame, IN.
- Sattler, W. 1963. Über den Körperbau, die Ökologie und Ethologie der Larve und Puppe von *Macronema Pict.*, ein als Larve sich von "Mikro-drift" ernährendes Trichoptera aus dem Amazonasgebiet. *Arch. Hydrobiol.* 59: 26–60.
- Schlosser, I. J. 1990. Environmental variation, life history attributes, and community patterns in stream fishes: implications for environmental management and resource assessment. *Environ. Manag.* 14: 621–628.
- SigmaStat. 1997. User's manual, version 2.0, SPSS, Chicago, IL.
- Strand, M. R., and R. W. Merritt. 1997. Effects of episodic sedimentation on the net-spinning caddisflies *Hydropsyche betteni* and *Ceratopsyche sparna* (Trichoptera: Hydropsychidae). *Environ. Poll.* 98: 129–134.
- Tachet, H., J. P. Pierrot, and M. Bournaud. 1986. Distribution of the *Hydropsyche* larvae and the structure of their nets, pp. 281–286. In *Proceedings of the Fifth International Symposium on Trichoptera*, 21–26 July 1986, Lyon, France. Junk, Boston, MA.
- [EPA] U.S. Environmental Protection Agency. 1990. The quality of our nation's water: a summary of the 1988 National water quality inventory. EPA, Washington, DC.
- Wallace, J. B., and D. Malas. 1976. The fine structure of capture nets of larval *Philopotamidae* (Trichoptera) with special emphasis on *Dolophilodes distinctus*. *Can. J. Zool.* 54: 1788–1802.
- Wallace, J. B., and R. W. Merritt. 1980. Filter-feeding ecology of aquatic insects. *Annu. Rev. Entomol.* 25: 103–132.
- Ward, J. V. 1992. *Aquatic insect ecology*. Wiley, New York.
- Waters, T. F. 1995. *Sediment in streams: sources, biological effects, and control*. Monograph 7. American Fisheries Society, Bethesda, MD.
- Williams, N. E., and H.B.N. Hynes. 1973. Microdistribution and feeding of the net-spinning caddisflies (Trichoptera) of a Canadian stream. *Oikos* 24: 73–84.

Received for publication 4 May 1999; accepted 30 September 1999.