

Substrate Architecture's Role in Food Availability and
Influence on Aquatic Invertebrate Colonization in a Littoral Zone

BIOS 569 - Practicum in Aquatic Biology

Cristopher Garlitz

227 Dillon Hall

Advisor- Dr. David Lodge

1991

Abstract

In a littoral habitat, how substrate architecture influenced invertebrate colonization and food availability was tested. Three imitation substrates of different architectural complexity were constructed to study the relationships between substrate architecture and invertebrate colonization. The imitation macrophytes used were *Isoetes*, *Sparganium*, and *Nuphar*, ranging from most complex to least complex. Each substrate had the same amount of surface area. Periphyton biomass densities ($p < .2336$) did not differ significantly between the three different substrates. *Isoetes* had the greatest invertebrate density per surface area ($p < .0001$). Three out of the six taxa observed were found in significantly higher densities on *Isoetes* than on the other two substrates. Coleopterans were found to colonize more on *Nuphar* ($p < .0001$). From the results, a definite preference for more complex substrates does exist. However, sometimes architecture accomodates invertebrates in other ways independent of complexities. Two predictions regarding food availability were made: 1) substrate complexity actually does not aid food accumulation; or 2) increased feeding caused by increased invertebrate densities significantly depletes the increased available food that had been aided by substrate arcitecture. Both predictions were shown to be possible compared to other studies.

Key words: *Isoetes*, *Sparganium*, *Nuphar*, imitation plants, substrate complexity, food availability, colonization.

Introduction

Macrophytes are often an inconspicuous element in studies concerning energy transfers in lakes. But, due to their close association with and importance to invertebrate survival, macrophytes could ultimately play an essential role in the energy transfer process (Miura et al. 1978, Dall et al. 1984, Kolodziejczyk 1984, Kairesalo & Koskimies 1987). Macrophytes do not only benefit invertebrates by direct consumption of the plant tissue itself (Lodge 1991), but they also indirectly affect herbivore feeding by collecting organic material, such as algae and detritus, which are ingested by certain invertebrates (Catteno 1983, Bronmark 1984). Besides being food sources, macrophytes also provide refuge from predation, spawning sites, sites for attachment (McDermid & Naiman 1983, Keast 1984, Rooke 1984, Dudley 1988), and sites to construct certain invertebrate artifacts such as nets (Rooke 1986b). Aside from helping invertebrate survival, macrophytes aid vertebrate survival such as fish and other aquatic dependent invertebrates because they feed on the abundant invertebrates that are found in macrophyte beds (Gerking 1962, Krull 1970, Crowder & Cooper 1982, Mittelbach 1984, Keast 1985, Murkin & Kladek 1986, Cyr & Downing 1988). Due to invertebrate and vertebrate dependence on macrophytes, their characteristics which are advantageous to invertebrate survival are important to study, especially since certain types of macrophytes provide these characteristics more for invertebrates.

Kershner and Lodge (1990) tested the importance of substrate architecture on invertebrate colonization. Architecture is only one of five factors that has been tested with substrate and invertebrate associations (Kershner & Lodge 1990). This particular experiment is an extension of their study in which all factors related to substrate/invertebrate associations, such as surface area, shelter, macrophyte specific precipitates or exudates, direct effect of fish predation and food availability, were controlled. Only food availability and plant structure were not controlled in this study. Whereas similar studies have been performed, they were in streams (Rooke 1986b, Dudley 1988), in marine habitats (Bell & Westoby 1986), or they did not measure directly for the effects of substrate shape and available nutritive resources (Cyr & Downing 1988). The goal of this study is to quantify invertebrate colonization on macrophytes in regards to the previously mentioned factors, by using plants of different structures in the littoral zone of a lake.

Apparently, substrate shape does play an important role in the colonization of invertebrates because many studies show they are not equally

Subst. Arch. and Invert. Colonization

abundant on all plant species (Soszka 1975, Gerrish & Bristow 1979, Rooke 1986b). Specifically, Kreeker's model (1939) suggests colonization is more likely on plants with more highly dissected leaves than on plants with broad leaves. The results of some studies have confirmed the findings of this model (Gerrish & Bristow 1979, Dvorak & Best 1982, Rooke 1986 a,b, Dudley 1988, Kershner & Lodge 1990). More important, Kershner and Lodge (1990) predicted numbers of invertebrates per surface area should increase more on highly dissected-leaved than on broad-leaved substrates. Their prediction was compared with stream studies (Rooke 1986, Dudley 1988), so this study will provide a comparison with a lentic habitat. Nonetheless, finely dissected-leaved plants must supply certain structural advantages over broad-leaved plants for invertebrate survival.

Indeed, Kershner and Lodge (1990) showed plant morphology affected snail colonization through two ways: 1) as bottom contact increases, snail substrate encounters increase; and 2) as bottom contact decreases, snails may be less likely to increase colonization due to the mechanics of their locomotion. In other words, prostrate and highly dissected substrates are more advantageous for snails because of physical constraints. Yet, many invertebrates which are not constrained to walking, but can swim such as odonates, have similar colonization tendencies also. In fact, Rooke (1986b), using plastic models, does claim substrate structure was not the only signal for invertebrate recognition, rather food availability may also be a determinant. Evidence exists that suggests prostrate and finely dissected substrates may also be advantageous to food accumulation (Dvorak & Best 1982, Rooke 1986a), and likewise attract more invertebrates (Merezhko 1973, Rooke 1984).

Moreover, plant architecture may be important to invertebrates because of environmental factors, such as current (Dudley 1988) which can be caused by wind, storms, or even animal interferences. These distractions can interrupt or destroy an invertebrate's chance of survival. Consequently, invertebrates may prefer dissected-leaved plants because they may provide protection from current (Gregg & Rose 1982) or stable substrates as opposed to filiform ones would also. This factor is important because some animals may be exposed to predators if they colonize on an unstable substrate (Wiley & Kohler 1984, Allan et al. 1986).

Likewise, invertebrate characteristics, such as building nets, could be connected with substrate/invertebrate association (Rooke 1986b). In other words, invertebrates specifically choose substrates which are advantageous to their functional demands. Some species feed on plant tissue (Merrit & Cummings 1978, Kangasnieme & Oliver 1983, Dudley 1988), some scrapers do not discriminate between substrates (Biggs & Malthus 1982), and larger substrates may support larger invertebrates (Cyr & Downing 1988). Thus, this experiment will attempt to associate any connections between invertebrate

Subst. Arch. and Invert. Colonization

feeding habits and substrates.

The ecological importance of this study is that it helps to explain what types of substrates invertebrates prefer. Since they are primary consumers in the food chain, their actions are important to life in a lake system. Through trophic cascading in such a system, excess growth of periphyton and phytoplankton may be controlled (Current study at Univ. of Wisconsin). Therefore, controlling substrate factors could ultimately help prevent lake eutrophication.

Since this experiment controls surface area, macrophyte exudates and precipitates, and predation, but not for substrate shape or food availability, some hypotheses can be stated concerning the experiment. First, substrate architecture will affect both colonization of invertebrates and food availability. More invertebrates should colonize on *Isoetes* because the highly dissected plant that grows closely to the bottom will provide better refuge from predation by other invertebrates, and will collect more food that falls from the water column, compared to *Sparganium* and *Nuphar*. Second, *Isoetes* will also support more invertebrates because they are not as affected by environmental changes as *Sparganium* and *Nuphar* are. *Sparganium* and *Nuphar* extend throughout the water column which increases their chances of disturbance from current. The increased exposure to current will disrupt the stability of an environment suitable to invertebrate survival, causing it to be exposed to more risk from such factors as predation. Finally, invertebrate substrate-specific characteristics will effect colonization. For instance, *Isoetes* may be highly colonized by predators because of the abundance of other invertebrates, or some invertebrates may prefer to colonize on *Nuphar* because they feed directly on its tissue.

Methods

In this experiment, imitations of three macrophytes common to Central Long Lake (Gogebic Co., Michigan), *Isoetes*, *Sparganium*, and *Nuphar*, were constructed to serve as substrates in the littoral zone. Each plant was made of polyethylene (plastic garbage bags) which refutes plant chemistry as having any possible connection with invertebrate substrate preference. The three substrates had equal surface areas of 168.5 cm². *Nuphar* had a flat, rectangular petiole (.75 cm X 60 cm) constructed of polyethylene. Its leaf was round (d=10 cm) and consisted of white shipping foam (in order to keep the leaf floating) with polyethylene attached on the underside (Figure 1a). The

Subst. Arch. and Invert. Colonization

petiole was glued to the middle of the leaf on one end and attached to a clay tile on the other end. All attachment in constructing each plant was achieved by using silicon caulk, so the plants would remain attached under water.

Sparganium consisted of three rectangular leaves (.4 cm X 60 cm) and one leaf (.45 cm X 10 cm and .32 cm X 50 cm) made of polyethylene. Two Styrofoam chips were attached at intervals along the last 10 cm of each leaf to simulate the floating of real *Sparganium*. The opposite ends of the leaves were attached together to the center of a clay tile (Figure 1b). *Isoetes*, consisting of flat, rectangular shoots (5 plants: 9 shoots per plant, 10 cm X .15 cm; 1 plant: 10 shoots per plant [same measurements as first 5 plants], with 1 shoot .175 cm X 10 cm), will be made of polyethylene with Styrofoam chips attached to the tips of the leaves. The opposite ends of the leaves were attached to the center of a clay tile (Figure 1c)(Place Fig. 1a,b, and c here- FIG. 1). (Measurements and descriptions of plants provided by Terry Ehrman; Table 1)(Place Table 1 here- TABLE 1w) Ten sets for each plant were constructed, but one set of each plant was lost during the experiment. Therefore, the ANOVA, used to compare the data, was based on 27 replicates, nine for each substrate.

The tiles with the attached plants were put into Central Long Lake (Max. depth 5 m, Mean depth 2 m, Area 2.1) at a depth of .5 m. The tiles were placed .5 m apart, alternating between each type, such as *Sparganium*, *Nuphar*, *Isoetes*, *Sparganium*, and so on. (Central Long Lake information was received from Dr. David M. Lodge) After four weeks in the lake, the plants were removed by snorkeling around the plants, placing plastic bags over a plant while still under water, and detaching them from the tiles. The bags containing the plants were twist-tied and taken back to the laboratory.

In the laboratory, the plants were each cleaned separately. The process consisted of rinsing a plant through a 1 mm mesh sieve. All water that went through the sieve was collected. (Rinse water from the sink was kept to a minimum, in order not to affect sample size greatly.) The plants were scrubbed by hand. Then, the surface of the mesh was cleared into a dissecting bowl. The invertebrates were picked from the sample, and preserved in 90% ethanol. Next, a 70-mL sub-sample of the remaining filtered water was thoroughly filtered through a 4.75 cm glass fiber filter placed on a suction apparatus. The glass fiber filter (Whatman Grade GF/F; pore size = .7 μ m) with its filtrate was dried in an oven at 60 C for 24 hours in order to obtain a dry weight of the sample. The above process was performed separately for each plant. All of the invertebrates were identified and all of the filters were weighed (to the nearest .001 g) and recorded. The same mean filter weight (.1275 g) from 99 filter measurements was used when weighing the filters to find the total dry weight. Finally, the total biomass weights, total invertebrate densities, and individual taxa densities were compared using ANOVA and Tukey's Multiple Comparison test.

Subst. Arch. and Invert. Colonization

Results

Periphyton Biomass

For the three substrates, periphyton biomass did not differ significantly among substrates (Fig. 2, ANOVA $p < .2336$ and Tukey's Multiple Comparison Test)(Place Fig. 2 here- TEXT [end]).

Comparison of Invertebrate Colonization

Overall, *Isoetes*, the most structurally complex of the three substrates, supported the highest numbers of total invertebrates per surface area (Fig. 3, $p < .0001$)(Place Fig. 3 here- TEXT [end]).

Although invertebrates as a whole preferred *Isoetes*, certain taxa, such as coleoptera, were not found in highest numbers on it. Three out of the six taxa observed in the experiment, amphipods ($p < .0317$), dipterans ($p < .0002$), and odonates ($p < .0001$) were most abundant on *Isoetes* (Fig. 4). Finally, a fourth group that also showed some preference for more structure was cladocerans (Fig. 4, $p < .0136$). Their colonization on *Isoetes* was significantly higher than on *Nuphar*, but not *Sparganium*. Increased colonization by both herbivorous and carnivorous invertebrates did occur on the most complex substrate.

In contrast, coleopterans were found at maximal densities on *Nuphar* (Fig. 4, $p < .0001$). In addition, other invertebrates, including trichopterans, did not show any significant difference ($p < .6127$) in colonization between the three substrates (Figs. 4)(Place Figs. 4a,b,c,d,e,f,and g here- TEXT [end]).

Cladocerans and dipterans comprised the biggest percentage of colonization on each plant (Fig. 5)(Place Figs. 5a,b, and c here- TEXT [end]). Also, the predatory odonates comprised a big portion of the total invertebrates on *Isoetes*, while coleopterans contributed largely to those on *Nuphar*.

Discussion

Overall, invertebrate colonization on the three different imitation plants does support the idea that increased substrate complexity does result in higher invertebrate colonization (Krecker 1939, Gerrish & Bristow 1979, Dvorak & Best 1982, Rooke 1986a,b, Dudley 1988, Kershner & Lodge 1990). The results from this experiment imply that invertebrates are more likely to colonize more structurally complex substrates because they can increase invertebrate survival. Increased survival from predation, higher probability for encountering prey, inherent behavioral characteristics specific to certain

Subst. Arch. and Invert. Colonization

invertebrates, and taxa-specific mechanisms all stemming from architectural complexity seem to determine colonization. Just as Bell & Westoby (1986) showed, complex habitats do determine colonization, and not predation. However, substrate architecture does not necessarily provide greater accumulation of food for invertebrate survival. Unfortunately, all conclusions made from this experiment concerning invertebrate features and their relations to substrates cannot be made with extreme confidence because the individuals were not able to be identified to the species level. Consequently, general features which apply to the certain orders as a whole will be used in an attempt to explain certain substrate-invertebrate associations.

Food Availability and Substrate Shape

The results from this experiment suggest no particular advantage because food accumulation is not related to increased dissection on substrates. No significant differences between *Isoetes*, *Sparganium*, and *Nuphar* biomass densities existed, even though *Isoetes* did amass slightly more than the other two plants. From this observation, two predictions concerning substrate architecture and food availability can be stated: 1) complex structures do not actually aid food availability; or 2) increased invertebrate densities due to architecturally better substrates significantly deplete increased food accumulation caused by the more highly dissected substrate. The first prediction is supported by Cyr & Downing (1988) who suggest algal abundance is an unlikely factor that occurred from substrate architecture, which in return increases invertebrate colonization. In fact, a direct observation of the results from this experiment supports their assumption. The more highly dissected and shorter *Isoetes* does not provide an advantageous structure for food availability compared to the less dissected and longer *Sparganium* and *Nuphar*. This conclusion asserts food availability is not related to substrate architecture. Therefore, it would not be an advantageous cue for substrate colonization.

On the other hand, the second prediction would support the conclusion that food availability is higher on structurally more complex substrates. This conclusion would support Rooke's assertion (1984, 1986b) that highly dissected substrates may provide structural characteristics advantageous to food build-up, resultantly increasing invertebrate colonization. Indeed, biomass depletion could have occurred on *Isoetes* because more invertebrates colonized the substrate, leading to greater feeding on the substrate. For example, significantly more cladocerans and dipterans colonized *Isoetes* than colonized *Sparganium* and *Nuphar*. Most littoral cladocerans are scrapers (Dodson & Frey 1991) which can significantly diminish algal and other food concentrations from their surroundings (Porter 1977, Balcer et al. 1984, Vanni 1986). Moreover, most of the dipterans found on *Isoetes* were probably

Subst. Arch. and Invert. Colonization

herbivores which used such methods as scrapping, shredding, or filtering (Cummins & Coffman 1991). These herbivorous actions would have decreased food that had accumulated. As a result, such total clearance of food from *Isoetes* by the greater amount of colonized invertebrates would explain why biomass is similar to the other two plants. If such depletion did occur, *Isoetes* would provide better structure for food availability because the biomass levels before invertebrate consumption would be well above those of *Sparganium* and *Nuphar*. Therefore, if prediction two is true, then food availability is increased with increased structural complexity. However, this experiment does not control herbivorous consumption, so it cannot provide conclusive evidence as to which prediction is correct.

Predator/Prey Encountering

Predators, such as odonates and dipterans, preferred the more structurally complex substrate. Since more invertebrates colonized *Isoetes*, predators had a better chance of finding food because of two factors. First, the complexity of *Isoetes* produced an exceptionally better habitat for the odonate's stalking nature (Westfall 1984, Hilsenhoff 1991). This habitat is beneficial to hiding the predators from prey because they will be able to blend with the surroundings or hide within the complex substrate itself. Furthermore, increased invertebrate densities on *Isoetes* due to its more complex structure increases the likelihood that a predator will encounter prey which it is able to ingest. Thus, predators benefit by colonizing on more complex substrates because more food is available.

Increased Prey Survival

Although *Isoetes*' morphology was advantageous to predators, it also offered more protection for prey from predators (Harrod 1964, Dvorak & Best 1982). Its highly dissected architecture and detrital cover also hid some invertebrates from other predacious invertebrates. This conclusion is strongly supported because the number of non-predatory invertebrates were as high as the number of predatory invertebrates. Even some predators feed on other predators (Hilsenhoff 1991). However, all invertebrate densities, whether predator or prey, were fairly high on *Isoetes*, suggesting prey were able to avoid predators enough to survive, and predators were able to obtain enough prey to survive. In fact, some studies do claim prey have a better chance of survival on structurally complex substrates due to decreased predation rates (Crowder & Cooper 1982, Savino & Stein 1982, Stoner 1982, Coull and Wells 1983). Prey that colonized on *Isoetes* was able to hide in the detritus around the plant and to blend in between the dissected structures. They also were not exposed throughout the water column which would increase their risk of being eaten. Prey on *Sparganium* and *Nuphar* had neither structure

Subst. Arch. and Invert. Colonization

nor close proximity of the entire length of their leaves to the lake bottom to protect invertebrates from predation.

In similar manner, Bell & Westoby (1986) showed prey chose structurally complex habitats, but not as a direct result of predation. Predation is however the secondary cause which drives this preference for complex substrates (Bell & Westoby 1986). Not only does their conclusion apply to marine habitats, but it also applies to lentic habitats as shown by this experiment. No vertebrate predation existed in this study, yet invertebrates still preferred the structurally complex *Isoetes*. Consequently, less overall predation in this habitat would occur in comparison to other habitats with predation by vertebrates, such as fish, as well as invertebrates. This decrease in predation would mean that prey would be less easily preyed upon. But, total invertebrate colonization did not even out in numbers on the less structurally complex *Sparganium* and *Nuphar*. As Bell & Westoby (1986) stated, less individuals in less structurally complex habitats is not a direct result from easier predation. Rather, the main mechanism driving more invertebrates to *Isoetes* is caused by predation as a secondary factor.

Taxa Specific Mechanisms in Invertebrate Colonization

The final aspect of this study suggests substrate complexity sometimes plays a role for invertebrate-specific mechanisms, and sometimes it does not. Studies have shown that certain characteristics or processes specific to certain taxa are related to substrate architecture (Biggs & Malthus 1982, Rooke 1986b, Kershner & Lodge 1990). Certainly, amphipods seemed to prefer *Isoetes'* complex structure since none of them were found on the other two less complex substrates. In one analysis, amphipod colonization was significantly higher on *Isoetes*. Amphipods are usually found under detrital material, under debris, or in masses of vegetation because these habitats are important to their inherent behavioral ways (Holsinger 1976). The short, structurally complex *Isoetes* catered well to an amphipod's characteristics, because of its position in relation to the lake bottom.

In contrast, complex structure does not always determine colonization for invertebrates due to specific characteristics. Some species feed directly on plants (Merritt & Cummins 1984). This characteristic is likely a reason why significantly more coleoptera colonized on *Nuphar*, the least structurally complex of the three plants. In fact, the real *Nuphar* in this habitat did have torn leaves and stems from consumption (personal observation). However, some coleopterans, such as chrysomelids, rely on *Nuphar* for mating or burrowing (Doyen & White 1984). If this be the case, then architecture still plays a role in colonization, but not because of increased plant complexity.

Indeed, the imitation *Isoetes*, *Sparganium*, and *Nuphar* did show

Subst. Arch. and Invert. Colonization

substrate architecture, especially complexity, is a factor in invertebrate colonization. The complex substrate-invertebrate relation makes it hard to decisively define preferences of substrates by different invertebrates. However, using imitation models did provide useful conclusions or mechanisms for understanding certain relations between substrate morphology, invertebrate preference, and available food. Some apprehension may occur from the use of imitation substrates in addressing such issues. But, Rooke(1986b) showed plastic imitations did follow real plant trends, but only to different degrees. Thus, these conclusions can be applicable to living substrates.

Acknowledgements

I would like to express my gratitude to The Bernard J. Hank Family Endowment which provided the funds for this course and the opportunity for this research. I give special thanks to Dr. David Lodge whose guidance and patience helped me throughout my research. I would also like to thank the advisors, teaching assistants, and students at UNDERC who helped me with my project, especially Dr. Martin Berg, Aimee Delach, and Jean Keaveney.

Literature Cited

- Allan, J.D., A.S. Flecker, and N.L. McClintock. 1986. Diel epibenthic activity of mayfly nymphs, and its non-concordance with behavioral drift. *Limnology and Oceanography* 31:1057-1065.
- Balcer, M.D., S.I. Dodson, and N.L. Korda. 1984. *Zooplankton of the Great Lakes: A Guide to the Identification and Ecology of the Common Crustacean Species*. The University of Wisconsin Press, Madison, Wisconsin.
- Biggs, B.J.F., and T.J. Malthus. 1982. Macroinvertebrates associated with various aquatic macrophytes in the backwaters and lakes of Upper Clutha Valley, New Zealand. *New Zealand J. Mat. Freshwater Biology* 16:81-88.
- Bell, J.D., and M. Westoby. 1986. Abundance of macrofauna in dense seagrass is due to habitat preference, not predation. *Oecologia* 68:205-209.
- Bronmark, C. 1985. Interactions between macrophytes, epiphytes, and herbivores: an experimental approach. *Oikos* 45:26-30.

Subst. Arch. and Invert. Colonization

- Cattaneo, A. 1983. Grazing on epiphytes. *Limnology and Oceanography* 28:124-132.
- Coull, B.C., and J.B.J. Wells. 1983. Refuges from fish predation: experiments with phytal meiofauna from the New Zealand rocky intertidal. *Ecology* 64:1599-1609.
- Crowder, L.B., and W.E. Cooper. 1982. Habitat structural complexity and the interaction between bluegills and their prey. *Ecology* 63:1802-1813.
- Cummins, K.W., and W.P. Coffman. 1984. Summary of ecological and distributional data for *Chironomidae* (Diptera), pp. 644-652. *In* R.W. Merritt and K.W. Cummins [eds.], *An introduction to the aquatic insects of North America*. Kendall/Hunt, Dubuque.
- Cyr, H., and J.A. Downing. 1988. The abundance of phytophilous invertebrates on different species of submerged macrophytes. *Freshwater Biology* 20:365-374.
- Dall, P.C., C. Lindegaard, E. Jonsson, G. Jonsson, and P.M. Jonasson. 1984. Invertebrate communities and their environment in the exposed littoral zone in Lake Birua. *Internationale Vereinigung fur Theoretische und Angewandte Limnologie Verhandlungen* 20:225-231.
- Dodson, S.I., and D.G. Frey. 1991. Cladocera and other branchiopoda, pp. 723-786. *In* J.H. Thorp and A.P. Covich [eds.], *Ecology and classification of North American freshwater invertebrates*. Academic Press, Inc., San Diego, California.
- Doyen, J.T., and D.S. White. 1984. Aquatic coloeptera, pp. 361-437. *In* R.W. Merritt and K.W. Cummins [eds.], *An introduction to the aquatic insects of North America*. Kendall/Hunt, Dubuque.
- Dudley, T.L. 1988. The roles of plant complexity and epiphyton in colonization of macrophytes by stream insects. *Verhandlungen der Internationale Vereinigung fur Theoretische und Angewandte Limnologie* 23:1153-1158.
- Dvorak, J., and E.P.H. Best. 1982. Macroinvertebrate communities associated with the macrophytes of Lake Vechten: structural and functional relationships. *Hydrobiologia* 95:115-126.
- Gerking, S.D. 1962. Production and food utilization in a population of bluegill sunfish. *Ecological Monographs* 32:31-78.
- Gerrish, N., and J.M. Bristow. 1979. Macroinvertebrate associations with aquatic macrophytes and artificial substrates. *Journal of Great Lakes Reserve* 5:69-72.
- Gregg, W.W., and F.L. Rose. 1982. The effects of aquatic macrophytes on the stream micro-environment. *Aquatic Botany* 14:309-324.
- Harrod, J.J. 1964. The distribution of invertebrates on submerged aquatic plants in a chalk stream. *Journal of Animal Ecology* 33:335-348.
- Hilsenhoff, W.L. 1991. Diversity and Classification of Insects and Collembola, pp. 593-663. *In* J.H. Thorp and A.P. Covich [eds.], *Ecology and*

Subst. Arch. and Invert. Colonization

- classification of North American freshwater invertebrates. Academic Press Inc., San Diego, Calif.
- Holsinger, J.R. 1976. The freshwater amphipod crustaceans (*Gammaridae*) of North America. E.P.A., Cincinnati, Ohio.
- Kairesalo, T., and I. Koskimies. 1987. Grazing by oligochaetes and snails on epiphytes. *Freshwater Biology* 17:317-324.
- Kangasniemi, B.J., and D.R. Oliver. 1983. Chironomidae (Diptera) associated with *Myriophyllum spicatum* in Okanagan Valley Lakes, British Columbia. *Canadian Entomology* 115:1545-1546.
- Keast, A. 1984. The introduced aquatic macrophyte, *Myriophyllum spicatum*, as habitat for fish and their invertebrate prey. *Canadian Journal of Zoology* 62:1289-1303.
- Keast, A. 1985. Planktivory in a littoral-dwelling lake fish association, prey selection, and seasonality. *Canadian Journal of Fisheries and Aquatic Sciences* 42:1114-1126.
- Kershner, M.W., and D.M. Lodge. 1990. Effect of substrate architecture on aquatic gastropod-substrate associations. *North American Benthological Society* 9(4):319-326.
- Kolodzieczyk, A. 1984. Occurrence of gastropoda in the lake littoral and their role in the production and transformation of detritus. *Ekologia Polska* 32:441-468.
- Krecker, F.H., 1939. A comparative study of the animal population of certain submerged aquatic plants. *Ecology* 20:553-562.
- Krull, J.N. 1970. Aquatic plant-macroinvertebrate associations and waterfowl. *Journal of Wildlife Management* 34:707-718.
- Lodge, David M. 1991. Herbivory on freshwater macrophytes. *Aquatic Botany*. 41:195-224.
- McDermid, K.J., and R.J. Naiman. 1983. Macrophytes: freshwater forests of lakes and rivers. *American Biological Teacher* 45:144-150.
- Merezhko, A.I. 1973. Role of higher aquatic plants in the selfpurification of lakes and rivers. *Hydrobiologia*. 9:103-109.
- Merritt, R.W., and K.W. Cummings. 1984. An introduction to the Aquatic Insects of North America. Kendall/Hunt, Dubuque.
- Mittelbach, G.G. 1984. Predation and resource partitioning in two sunfishes (*Centrarchidae*). *Ecology* 65:499-513.
- Miura, T., Tanimizu, Y. Iwasa, and A. Kawakita. 1978. Macroinvertebrates as an important supplier of nitrogenous

Subst. Arch. and Invert. Colonization

- nutrients in dense macrophyte zone in Lake Birua. *Internationale Veringung fur Theoretische und Angewandte Limnologie Verhandlungen* 20:225-231.
- Murkin, H.R., and J.A. Kadlec. 1986. Relationships between water fowl and macroinvertebrate densities in a northern prairie marsh. *Journal of Wildlife Management* 50:212-217.
- Porter, K.G. 1977. The plant animal interface in freshwater ecosystems. *American Scientist* 65:159-170.
- Rooke, J.B. 1984. The invertebrate fauna of four macrophytes in a lotic system. *Freshwater Biology* 14:509-513.
- Rooke, J.B. 1986a. Seasonal aspects of the invertebrate fauna of three species of plants and rock surfaces in a small stream. *Hydrobiologia* 134:81-87.
- Rooke, J.B. 1986b. Macroinvertebrates associated with macrophytes and plastic imitations in Eramosa River, Ontario, Canada. *Archiv fur Hydrobiologie* 106:307-325.
- Savino, J.F., and R.A. Stein. 1982. Predator-prey interaction between the largemouth bass and bluegills as influenced by simulated submerged vegetation. *Trans-American Fish Society* 111:255-266.
- Soszka, G.J. 1975. The invertebrates on submerged macrophytes in three Masurian lakes. *Ekologia Polska* 23:371-391.
- Stoner, A.W. 1982. The influence of benthic macrophytes on the foraging behavior of pinfish, *Lagodon rhomboides* (Linnaeus). *Biological Ecology* 58:271-284.
- Vanni, M.J. 1986. Competition in zooplankton communities: Suppression of small species by *Daphnia pules*. *Limnology and Oceanography* 31:1039-1056.
- Westfall Jr., M.J. 1984. Odonata, pp.126-176. In R.W. Merritt and K.W. Cummings [eds.], *An introduction to the aquatic insects of North America*. Kendall/Hunt, Dubuque.
- Wiley, M.J., and S.D. Kohler. 1984. Behavioral adaptations of aquatic insects pp. 101-133. In Resh, V.R., and D.M. Rosenberg [eds.], *The ecology of aquatic insects*. Praeger Publishers, New York.

Figure Legends

Figure 1a, b, and c: Actual models and measurements for each of the substrates used in the experiment. Figure 2: Mean total periphyton

Subst. Arch. and Invert. Colonization

biomass for each substrate ($p = .2336$). Tukey's shows no significant difference between any of the substrates.

Figure 3: Mean total invertebrate densities for each substrate ($p = .0001$).

Tukey's shows a significant difference between *Isoetes* and *Nuphar*, but not between *Sparganium* and the other two substrates.

Figure 4a: Mean total amphipod densities for each substrate ($p = .0317$).

Tukey's shows no significant difference between the three substrates.

b: Mean total cladocera densities for each substrate ($p = .0136$). Tukey's shows a significant difference between *Isoetes* and *Nuphar*, but not between *Sparganium* and the other two substrates.

c: Mean total coleoptera densities for each substrate ($p = .0001$). Tukey's shows a significant difference between *Nuphar* and the other two plants.

d: Mean total diptera densities for each substrate ($p = .0002$). Tukey's shows a significant difference between *Isoetes* and the other two plants.

e: Mean total odonata densities for each substrate ($p = .0001$). Tukey's shows a significant difference between *Isoetes* and the other two substrates.

f: Mean total other densities for each substrate ($p = .2336$). Tukey's shows no significant difference between any of the substrates.

g: Mean total trichoptera densities for each substrate ($p = .3520$). Tukey's shows no significant difference between any of the substrates.

Figure 5a, b, and c: Each figure shows the percent composition of each individual taxa of the total invertebrates for each substrate.

Nuphar (Fig. 1a)

$r=5\text{ cm}$
 $l=60\text{cm}$
 $w=.75\text{ cm}$
 $S.A.=168.5\text{cm}^2$

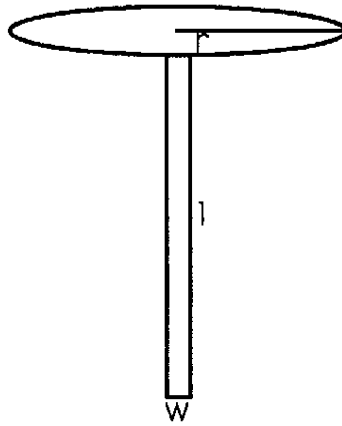

Sparganium (Fig. 1b)

$l=60\text{cm}$
 $w=.4\text{cm}$
 $S.A.=168.5\text{cm}^2$

4 leaves/plant

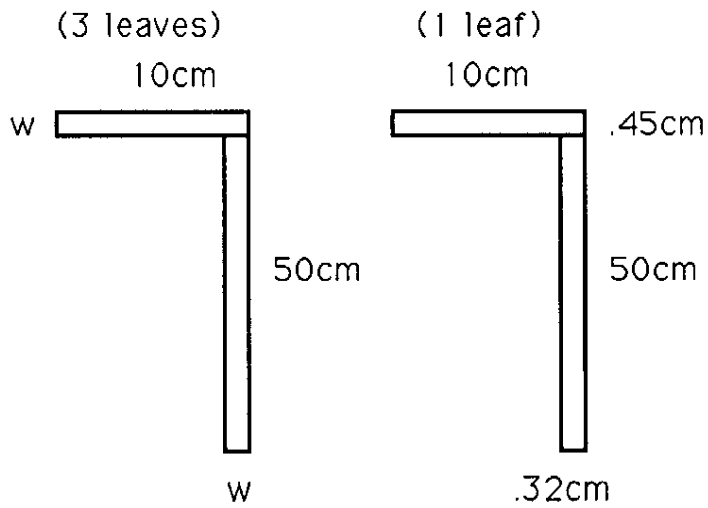

Isoetes (Fig. 1c)

$l=10\text{cm}$
 $w=.15$
 $S.A.=168.5\text{cm}^2$

5 plants (9 reg. leaves)
 1 plant (10 reg. leaves
 & 1 other leaf)

Regular leaf

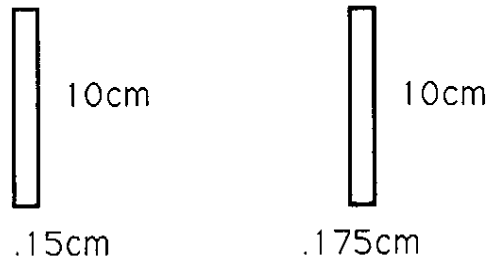

Table 1- Mean Measurements for Actual Substrates

Nuphar

Leaf: Rounded heart shape
Diameter- 20cm
Petiole: semi-circular in cross section
Length- 1 m
Width- .75 cm

Sparganium

Leaf: Flat in cross section
Length- 1 m
Width- .4 cm
5 leaves per plant

Isoetes

Leaf: Cylindrical in cross section
Length- 7 cm
Width- .1 cm
9 leaves per plant

Fig. 2

Tot. Algae

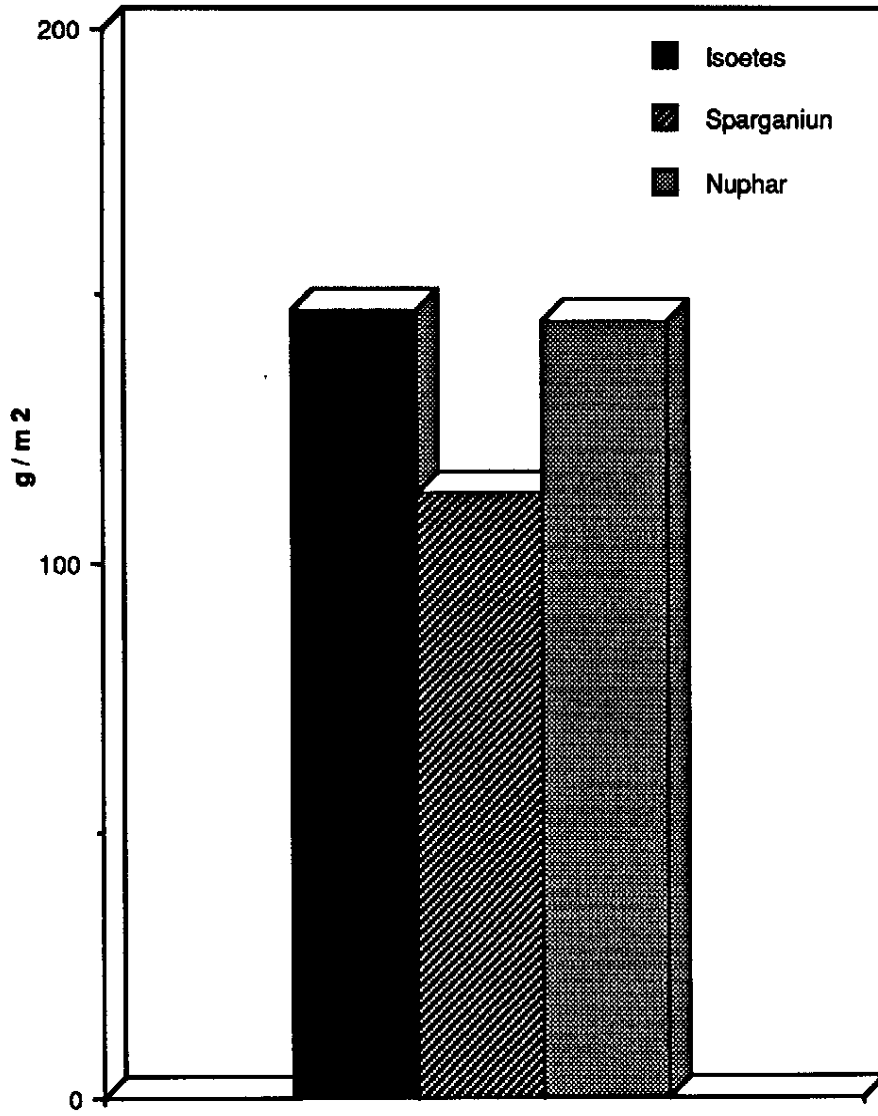
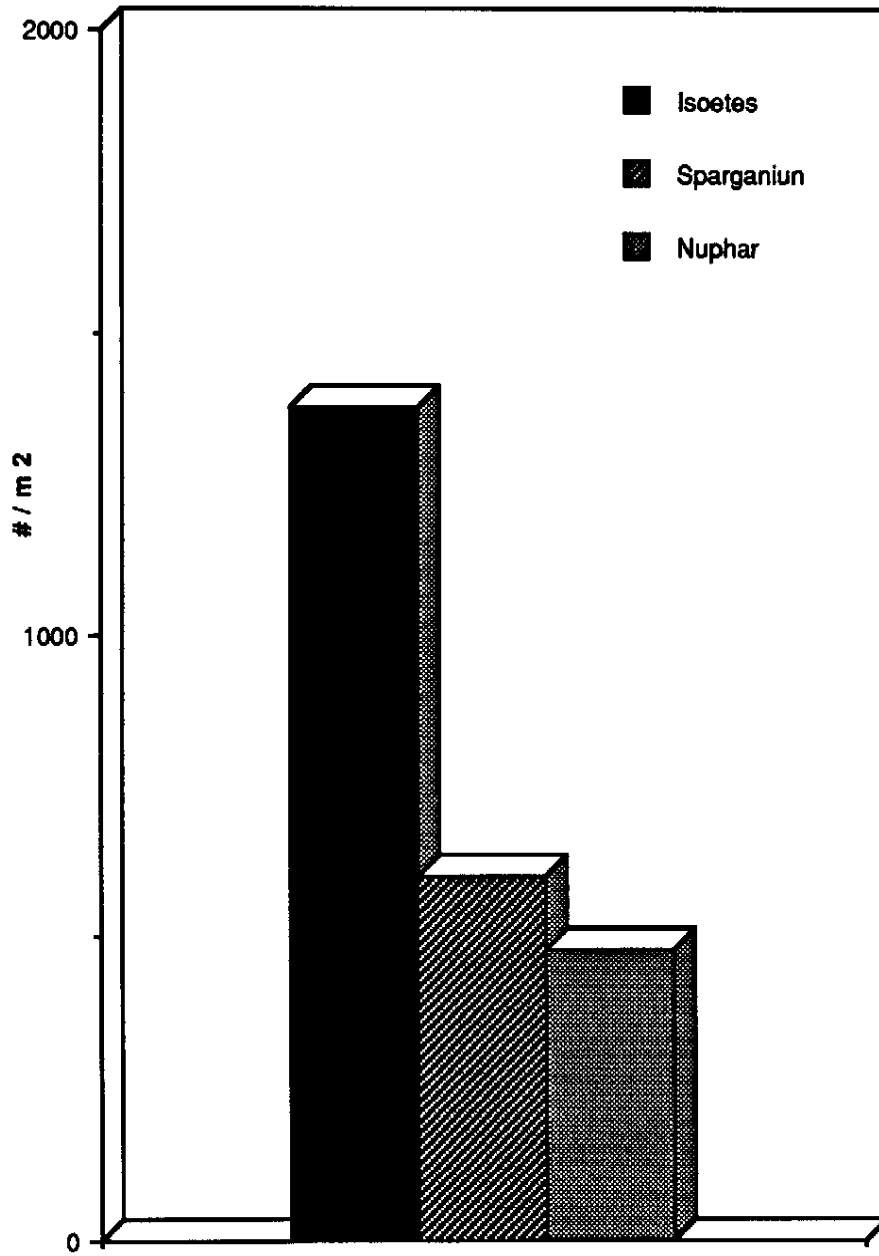

Fig. 3

Tot. Invertebrates



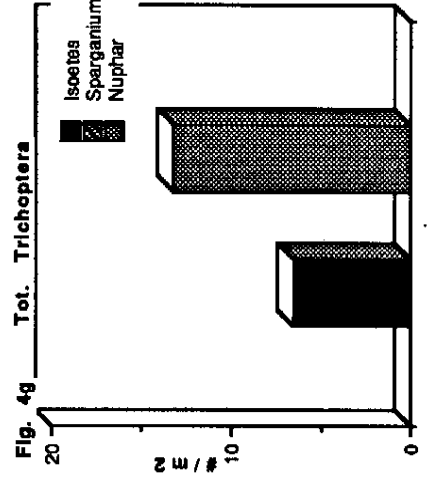
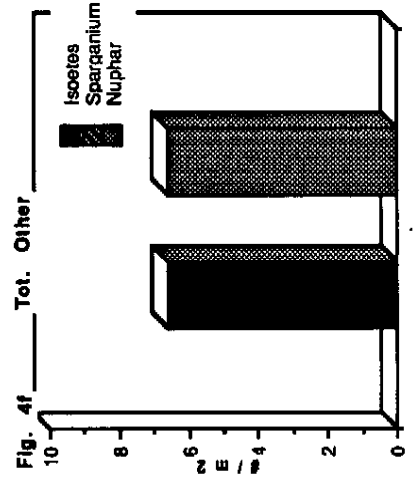
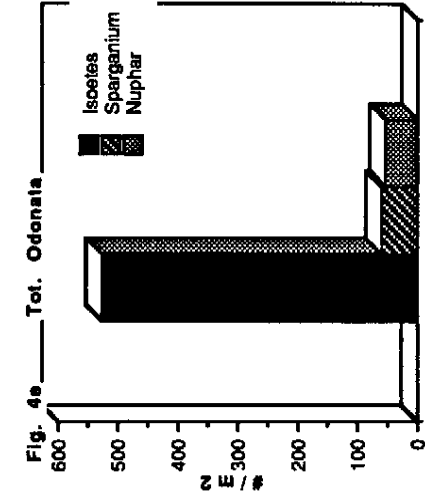
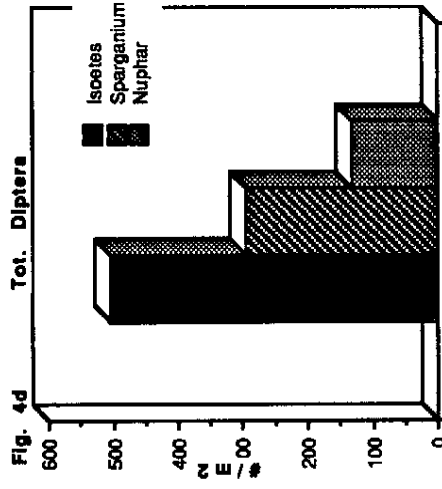
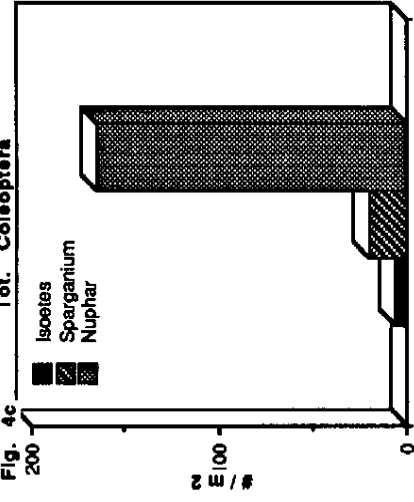
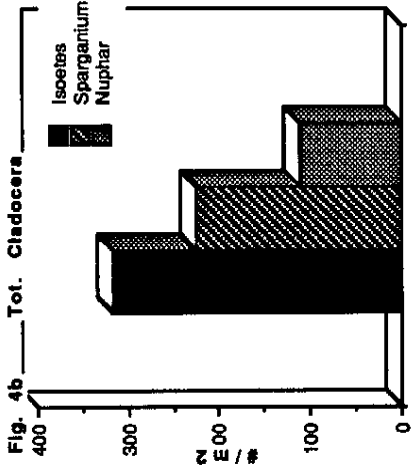
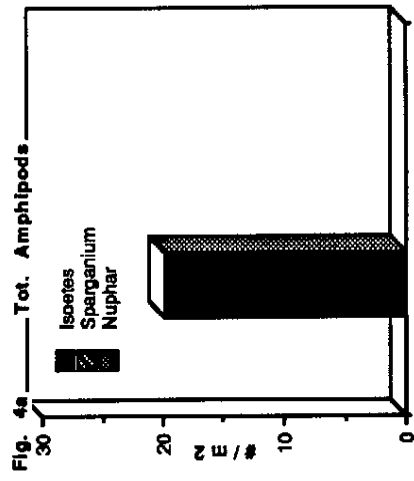
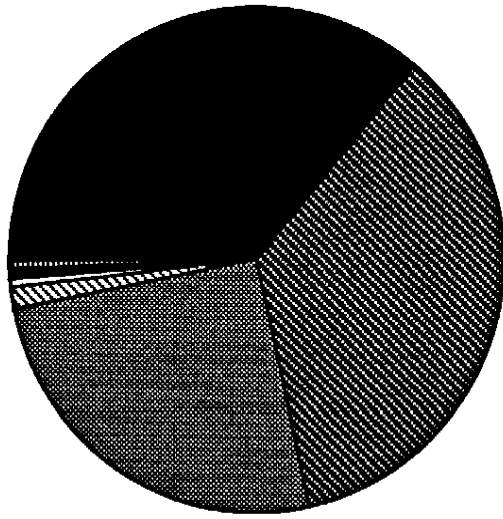
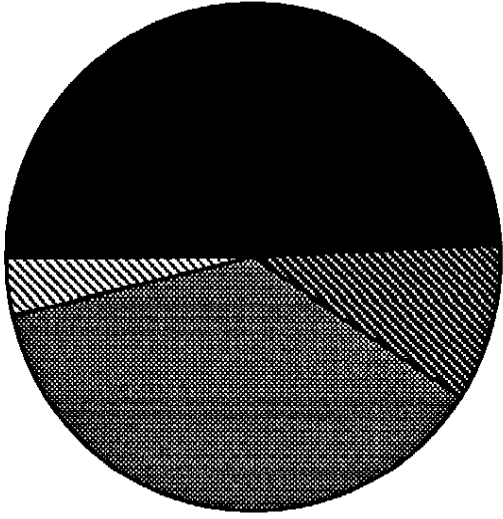

Figure 5a (% Invertebrates on Isoetes)



- Diptera
- ▨ Odonata
- ▩ Cladocera
- ▧ Amphipods
- Trichoptera
- Coleoptera
- ▨ Other

Figure 5b (% Invertebrates on Sparganium)



- Diptera
- ▨ Cladocera
- ▩ Odonata
- ▧ Coleoptera

Figure 5c (% Invertebrates on Nuphar)

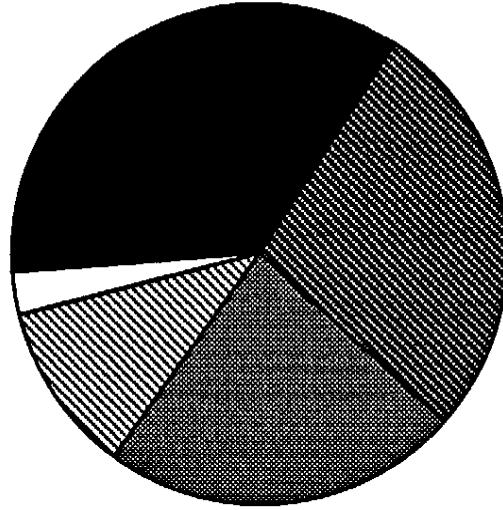

- Coleoptera
- ▨ Diptera
- ▩ Cladocera
- ▧ Odonata
- Trichoptera
- Other