

# Effects of Testosterone on the Mating Behavior of Hyla Versicolor

By: Christine Allison

University of Notre Dame, Notre Dame, In 46556

1990

## Abstract

In this experiment male tree frogs, Hyla versicolor, were injected with dihydrotestosterone during their mating season to test the effects of the steroid on their mating behaviors. The steroid was given to the frogs in a mixture of cocoa butter so that the cocoa butter mixture would harden and disperse the drug into the frogs' system gradually. I hypothesized that the testosterone would have an effect on mate calls, release calls, aggressive behavior, and territorial behavior. My findings suggested that testosterone does have an effect on aggression and release calling, but evidence for it's effects on the other two categories was minimal.

## Introduction

This experiment was created to test the effects of the steroid hormone, testosterone, on the mating behavior of male Hyla frogs. Wells and Bard found that in Hyla ebraccata females responded more favorably to multi-note mating calls than to single-note calls (Wells, 1987). Thus, it would appear that if testosterone has an affect on mating behavior it should produce an increase in multi-note calls and therefore an increase in duration of the calls of males so as to increase their likelihood of finding a mate. In studies of Hyla arborea savignyi calling males exhibited territorial behavior by keeping a minimum of 30 cm from other calling males. If the 30 cm space was invaded by another male, the frog would either become silent, or it would react aggressively. Thus, it exhibits it's territorial tendencies as well as it's aggressive

behaviors (Brzoska, 1983). Testosterone, which has been proposed to increase aggressive tendencies, will be examined for these behaviors in this experiment also.

Steroid hormones are secreted from the testis under the direction of gonadotropins. The principal steroid hormones produced in the males are testosterone and (5 alpha) dihydrotestosterone (Chester-Jones, 1987). These two hormones appear to have an affect on mating behavior according to a number of experiments. During the breeding season, more testosterone and dihydrotestosterone can be found in the blood than at any other time (Chester-Jones, 1987). Since the levels are highest during the breeding season, the hormones may be creating an effect on the sexual behavior. An experiment performed on T. granulosa males showed that testosterone and dihydrotestosterone could initiate mating behaviors even after the animal had been castrated. (The mating behaviors were halted upon castration) (Moore, ?). Kelly and Pfaff were able to restore amplexic clasping, a normal mating behavior, in castrated X. laevis by injecting testosterone into the animal (Moore, 1983). Also, Rana pipiens male sexual behaviors have also been caused by testosterone under certain conditions as reported by Kelley and Pfaff (Moore, 1983). It also appears that when plasma levels of testosterone are greater, reproductive behaviors occur. Although changes in plasma levels are seasonal, "testosterone concentrations cannot be correlated with behavioral activity at any particular season" (Moore, 1983). Testosterone and the other gonadal steroids are found in the highest concentrations at neural sites. These neurons are the ones associated with reproductive behaviors (Moore, 1983). The neurons' integrity appear to survive due to these hormones (Chester-Jones, 1987). All of the above experiments lead to the hypothesis that the addition of testosterone into male Hyla versicolor should produce measurable affects on the mating behaviors.

## Materials and Methods

The experiment began by making observations of the Hyla versicolor in the wild. Unfortunately, the frogs were the most active at night making them difficult to sight without the aid of a flashlight, which would have alerted the frogs to our presence. Thus, no data was collected on their behavior outside of the lab. We discovered that the male frogs could be tracked down by listening for their mating calls. By listening for the calls, the frogs were discovered calling at the water's edge. On May 31, 1990 nine H. versicolor were captured from the a small bog on the University of Notre Dame property in Land O' Lakes, Wisconsin. On June 2, 1990 ten more Hyla were collected, making a total of nineteen frogs. A benefit to catching the frogs by their call was that it assured us their sex since only the male frogs produce mating calls. The frogs were divided among four standard-size terrariums labeled T1-T4. Five frogs were placed into three of the terrariums and four were placed into another. All of the terrariums were set up similarly and as close as possible to the natural habitat. Water from the bog they were captured in was used to fill each of the terraria with approximately an inch of water, and tree branches and rocks found in the same area were also placed in the terraria. This set up allowed the frogs to climb or swim as they would be able to in the wild. The frogs were fed a variety of insects during the course of their captivity. The terraria were only cleaned once during the captivity period. The Hyla were observed during the nights prior to the injections for information on their territoriality, calling, and aggressiveness.

The frogs were in captivity for twenty-nine days before the injections on June 28, 1990. All of the frogs were measured and marked by toe clipping. Cocoa butter was melted and then 2mg of dihydrotestosterone was added so that .2g per 1ml of cocoa butter was injected into each of the frogs in T1 and T4. The mixture was injected into the frogs' abdominal cavities where it would harden and form a small lump that would gradually allow the dispersal of the testosterone over time. One frog in T4 had

complications with the injection and was not used bringing the number of experimental frogs to nine. The nine frogs in T2 and T3 were injected with plain cocoa butter to act as the controls. The frogs were seldom handled during their time in captivity, and their environments were not changed after the injections except for the addition of water once to bring the level in the cages back up to an inch.

Following the injections, the frogs were observed every three nights from June 28 until July 16. A red light was used in the room so that the frogs would not notice the observer. Each terrarium was broken down into six equal sections. These were used to keep track of the frogs' territories. Each observation night a map of the frogs' positions in the terraria was made. A tape recorded version of Hyla mate calling in the wild was played to try to incite the frogs to begin making mating calls. The frogs were observed for any signs of aggressive activity and the results were recorded. Information on release calls was obtained in two ways. The experimenter listened for any of the barking-type release calls during the observation nights and also simulated amplexic clasping on the frogs to procure the calls. This simulation was done by grabbing the frogs from behind around the abdomen, near the back legs, and gently applying pressure to the area. The results of all of these observations were recorded.

## Results

The Hyla versicolor were in captivity for a total of 46 days. The general activity levels of the Hyla remained the same throughout the captivity time. They were always very passive during daylight hours and more active at night. The frogs seemed to prefer to eat smaller insects such as damselfly, moths, and young grasshoppers instead of eating the larger insects such as the dragonflies.

Only a few times during this period did the frogs make any type of calls. During the time period after the injections no mating calls were recorded from either the control or experimental frogs. Simulated clasping on the frogs never produced any release

calling, although uninitiated release calls were recorded on three separate dates. On July 4, 7, and 16 release calls came from the experimentals in T1 (Table 3). On July 16, a faint release call also came from control T2. In general, release calls came from the testosterone injected frogs more often than the controls.

During the day the Hyla showed no fear of contact with one another. They often sat side to side or even on top of one another. Yet there were five recorded instances of aggressive behavior among the frogs during the night (Table 4). Frogs were seen engaged in pushing activities to claim certain places on the glass walls of the tanks. In all three of these instances, the frogs were exhibiting aggression in the same quadrant (4) of each terrarium. These behaviors occurred on the same three dates that the release calls were produced. The average temperature on these three days was  $11.87 \pm 3.15^{\circ}\text{C}$ , while the average temperature of all the observation days together was  $9.94 \pm 1.74^{\circ}\text{C}$ . The aggressive behaviors in T1 were between a 4cm, 4.1cm, and a 4.6cm frog (Table 5). In T2, between 4.2cm and 4.5cm frogs; and in T4 between 4cm and 4.4cm frogs. In both the experimental terraria, the 4cm frogs were the main aggressors, while in the control tank the main aggressor was the larger frog.

The favorite quadrants (Figure 2) of the terraria were determined by the percent of observation time a frog spent in each. A comparison of these favorite areas before and after injection lead to the conclusion that the control frogs switched territories more often than the experimental frogs (Table 6). A comparison of aggression and percentage of time spent in a particular area showed that in most cases, the frogs were fighting for their favorite territories (Table 7).

## Discussion

Release calls were only given by the Hyla on three days, but during these occasions it was the testosterone-injected frogs which called more often and the call from the control was fainter. Since release calls imply amplexic clasping, this result

was somewhat incongruous with the results of Kelley and Pfaff (1976). They found that both testosterone and dihydrotestosterone pellet implantations restored clasping to castrated Xenopus laevis. Yet, these results may be due to the species used. Palka and Gorbman (1973) injected different concentrations of testosterone into castrated Rana pipiens, and the steroid had no effect on either calling or clasping. Similarly, using R. pipiens, Wada and Gorbman (1977) found no increased clasping when testosterone was injected systemically, but the steroid injected into the preoptic nucleus of the frog did cause clasping to occur. The low frequency of calls in this experiment and the lack of reaction to clasping may be due to lack of effect of the steroid, or to the site of the injection since Hyla are more similar to Rana than to Xenopus. Also, the frogs may not have responded to the simulated clasping because the experimenter was not clasping the correct place on the frogs, or because they had become accustomed to being handled (although there was a minimal amount of handling by the experimenter).

The same nights that release calls were made, aggressive behavior was recorded. One frog would push against the body of another frog until one of the frogs moved to a new place on the glass, or fell into the water. The frogs may all have done the most fighting in quadrant 4 because it was the closest spot to the center of the room, so it may have been slightly warmer. Yet, the difference in temperature would have been extremely minimal if it had been recorded. The experimental frogs exhibited this aggressive behavior more often than the controls also. The correlation between release calls and aggressive behavior can only be explained by the fact that the average temperatures of these days was higher than the general average. Yet, the overlap of these temperatures suggests no real difference. The temperatures on the days before and after may have affected these activities and should be recorded in following experiments. The Hyla may have become more active during warmer

weather, or possibly more testosterone is naturally produced during warmer temperatures, but this is hard to derive from the temperatures we collected.

The most aggressive frogs in both T1 and T4 were the smallest frogs. This is a direct effect of the testosterone concentration in their bodies compared to the concentration in the larger frogs. The same amount of steroid was injected into all frogs regardless of size differences, so the smaller frogs would actually have a higher concentration in their bodies. The more aggressive frog in the control terraria was the larger frog, indicating that the testosterone did have an effect on the aggressive behaviors of the small frogs.

Since the terrariums were too small for the frogs to make their own distinct separate territories, it was difficult to acquire much information on their territorial behavior. Territories for H. versicolor have been shown to directly relate to mating call sound levels (Fellers, 1979). Our discrepancies in territorial behavior are a direct affect of our lack of mating calls. The favored quadrants were based on the area of the tank that the frogs frequented the highest percentage of observed time. We determined areas where the frogs spent greater than 60% of the time as territories. The experimental frogs remained in the same quadrants before and after the injection, whereas the control frogs switched quadrants more considering before and after injections. This indicates that the testosterone made the frogs more apt to remain in their territories. The control frogs did not show much concern for frequenting the same places. The aggressive behaviors that did occur were all among the frogs that wanted to be in the same area at the same time. Thus, the frogs, in all cases, became more aggressive when their territories were invaded. The general aggressive tendencies may be a direct effect of the small territory sizes as in the Hyla savignyi, who became more aggressive when their 30cm space was invaded (Brzoska, 1983).

The lack of mating calls from the Hylid frogs may have shown that there is no link between testosterone levels and mating calls, or it may have occurred due to the

effects of captivity. It was most likely due to the latter since testosterone and dihydrotestosterone were used to increase calling in castrated X. laevis (Wetzel and Kelley, 1983), although the species difference may once again be a factor. The frogs may have been too close to each other to call and were using silence as a response to the close proximity (Brzoska, 1983). This lack of calling may also have kept the aggressive acts lower since some species initiate calls before and during fights (Arak, 1983). The photoperiods of the frogs may also have been disturbed since they were kept inside with only one large window for light. The change in photoperiod may have confused the frogs as to what season they were in, thereby inhibiting their desire to call. The main missing factor to incite mate calling may have been the absence of a female nearby. In other studies of Hylid frogs, the approach of a female increased the calling of male frogs (Joermann and Sinsch, 1988).

The length of captivity was an important factor in this experiment. Captivity is very stressful on animals. This stress may have hampered the frogs from reacting to the mating season as they would normally. As frogs are in captivity their testosterone levels fall, thus there may have been less significant effects in the experimentals than expected because the steroid injection brought them back to a normal level but did not surpass it significantly. In future experiments, it may be wise to increase the concentration of testosterone injected per frog, so that it would be dispersed in their bodies more quickly at higher levels. It would also be helpful to contain the frogs in a large area where they have more distance between them as they do in the wild, and to keep the cages in an area where the light levels are more similar to the natural levels. Also temperatures should be regulated according to the conditions outside. Females should be brought into the area of the frogs to act as a stimulus for the mating behaviors. Feeding the frogs the same amount on a regular basis should be implemented to keep their nutritional levels constant. The temperatures should be taken near the cage every day and at different times during the day. Finally, less

disturbance in the room where they are kept during the day and longer observation periods would improve the results.

Research on testosterone and other steroids may lead to a better understanding of the effects that steroids have on athletes that use them. The specific side effects of steroid use need to be better understood, so people will be able to realize the dangers and/or benefits of the drugs they may be using. These steroids are normally occurring in the human body also. An understanding of their effects can lead to new improved ways of treating disorders associated with them, as well as pinpointing areas of the body where their specific effects may be unknown.

#### Acknowledgements

I would like to thank the Hank family for providing the funding for me to attend this special session of classes and to learn about environmental research firsthand. All of the professors that came up to teach and advise us deserve much credit for making the experience so interesting. I especially want to thank Dr. Boyd for advising my research project and assisting me through the difficulties of writing this paper.

**Table 1. Frog Size**

Each frog was measured on the same day by the same person. The length was taken from the tip of the nose to the tip of the body.

Terrarium #1 - Experimental

<u>Frog Numbers</u>	<u>Length (cm)</u>
1	4.1
2	4
3	4.5
4	4
5	4.6

Terrarium #2 - Control

<u>Frog Numbers</u>	<u>Length (cm)</u>
1	4.7
2	4.4
3	4.2
4	4.5

Terrarium #3 - Control

<u>Frog Numbers</u>	<u>Length (cm)</u>
1	4.6
2	4
3	4
4	4
5	3.8

Terrarium #4 - Experimental

<u>Frog Numbers</u>	<u>Length (cm)</u>
1	4.4
2	4.5
4	4
5	4.2

**Figure 1.**

Each terrarium was set up in the following arrangement. Approximately 1inch of water was added to the bottom of each. All of the rocks, branches, and moss were taken from their original habitat.

Top View

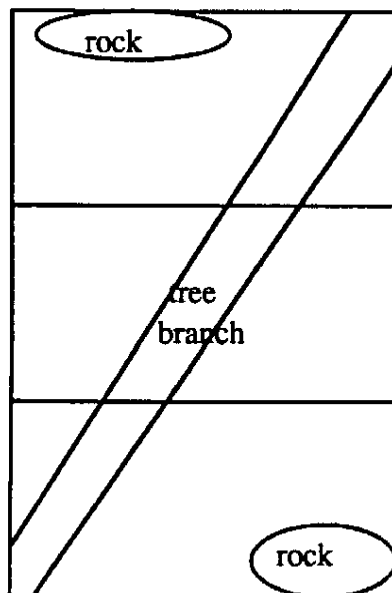

**Table 2.**

**Temperatures**

**For all observation days:**

<b><u>Date (1990)</u></b>	<b><u>Temperatures (°C)</u></b>
6/28	11.8
7/1	8.9
7/4	18.9
7/7	5.6
7/10	10
7/13	3.3
7/16	11.11

Average Temperature = 9.94 °C  
Standard Error of the Mean = 1.74

**Temperatures on nights when release calls and aggressive behavior occurred**

<b><u>Date (1990)</u></b>	<b><u>Temperature (°C)</u></b>
7/4	18.9
7/7	5.6
7/16	11.11

Average Temperature = 11.87 °C  
Standard Error of the Mean = 3.15

**Table 3.**

Release Calls and Temperature

The dates on which release calls were recorded are compared with the temperatures of those dates. The results show that most of the release calls occurred in the experimental terrarium #1.

<u>Dates (1990)</u>	<u>Terrariums Behav. Occurred in</u>	<u>Temp. (°C)</u>
7/4	1	18.9
7/7	1	5.6
7/16	1,2	11.11

**Table 4.**

Aggression and Temperature

The dates on which aggressive behavior occurred are the same dates that the release calls were recorded. Both terrariums 1 & 4 were experimental.

<u>Dates (1990)</u>	<u>Terrariums Behav. Occurred in</u>	<u>Temp. (°C)</u>
7/4	4	18.9
7/7	1,2	5.6
7/16	1,2	11.11

**Table 5.**

**Aggression and Size**

The frogs that exhibited aggressive behavior were compared to their size. In the experimental terrariums, the smallest frogs were the most aggressive. In the control terrarium, the larger frog was more aggressive.

<u>Terrarium in which Aggression Occurred</u>	<u>Length (cm) of frogs involved</u>
1	4.6, 4.1, <b>4</b>
2	<b>4.5</b> , 4.2
4	4.4, <b>4</b>

\* The bold-faced numbers represent the most aggressive frogs in each terrarium.

Figure 2.

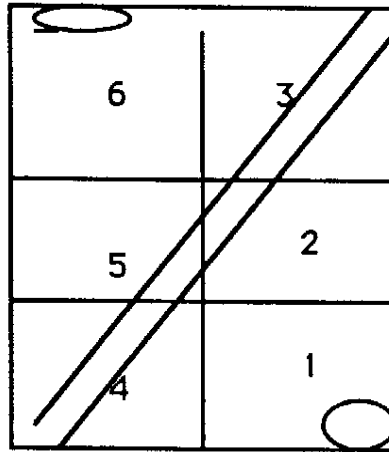

Each terrarium was divided into 6 quadrants.

**Table 6.**

**Territorial Behavior**

Each frog spent a certain amount of time in each quadrant. The greatest amount of time spent in a specific quadrant is shown. The remainder of the time was mixed between all of the other quadrants. These tables attempt to show the favorite quadrant for each frog; the area may be considered the frog's territory if over 60% of the recorded time was spent there.

Favored quadrants *before* injections:

<u>Frog Number</u>	<u>Terrarium #1</u> <u>Favored Quadrant</u>	<u>Percent of time in quad.</u>
1	3	40%
2	3	50%
3	1	60%
4	5	80%
5	4	100%

<u>Frog Number</u>	<u>Terrarium #2</u> <u>Favored Quadrant</u>	<u>Percent of time in quad.</u>
1	4	40%
2	1	100%
3	6	50%
4	6	66.7%

<u>Frog Number</u>	<u>Terrarium #3</u> <u>Favored Quadrant</u>	<u>Percent of time in quad.</u>
1	4	60%
2	1	60%
3	6	40%
4	1	80%
5	4	100%

<u>Frog Number</u>	<u>Terrarium #4</u> <u>Favored Quadrant</u>	<u>Percent of time in quad.</u>
1	4	60%
2	2	60%
4	4	60%
5	6	40%

Favored quads. *after* injections:

<u>Frog Number</u>	<u>Terrarium #1</u> <u>Favored Quadrant(s)</u>	<u>Percent of time in quad.</u>
1	1,4	27% in each
2 *	3	37.5%
3	4	62.5%
4 *	4,5	44% in each
5 *	1,4	30%

<u>Frog Number</u>	<u>Terrarium #2</u> <u>Favored Quadrant</u>	<u>Percent of time in quad.</u>
1	1	27%
2 *	1	33%
3	4	50%
4	4	44%

<u>Frog Number</u>	<u>Terrarium #3</u> <u>Favored Quadrant(s)</u>	<u>Percent of time in quad(s).</u>
1 *	4	50%
2 *	1	38%
3 *	4,6	33.3% in each
4	4	33%
5	6	50%

<u>Frog Number</u>	<u>Terrarium #4</u> <u>Favored Quadrant(s)</u>	<u>Percent time in quad.</u>
1 *	4	37.5%
2	4	33%
4 *	4	41.6%
5 *	4,6	37.5% in each

\* Represents frogs whose favored quadrants did not change before and after injection.

**Table 7.**

**Aggression and Territory**

The frogs that exhibited aggressive behavior were often ones that favored the same quadrants.

<u>Aggressive Frog #</u>	<u>Terrarium #1</u>	<u>Favored Quadrants</u>
1		1,4
2		3
5		1,4

<u>Aggressive Frog #</u>	<u>Terrarium #2</u>	<u>Favored Quadrants</u>
3		4
4		4

<u>Aggressive Frog #</u>	<u>Terrarium #4</u>	<u>Favored Quadrants</u>
1		4
4		4

## Bibliography

- Arak, Anthony. 1983. Vocal Interactions, Call Matching and Territoriality in a Sri Lankan Treefrog, *Philautus leucorhinus*. *Animal Behavior*. 31: 292-302.
- Brzoska, Josef, Hans Schneider and Eviatar Nevo. 1982. Territorial behavior and vocal response in male *Hyla arborea savignyi*. *ISR J Zool*. 31(1/2): 27-37.
- Chester-Jones, I. P.M. Ingleton, and J.G. Phillips. 1987. Fundamentals of Comparative Vertebrate Endocrinology. Plenum Press, New York. 207-221.
- Fellers, Gary M. 1979. Aggression, Territoriality, and Mating Behavior in North American Treefrogs. *Animal Behavior*. 27: 107-119.
- Joermann, Gerhard, and Ursula Sinsch. 1988. Vocalization and Mating Behavior of the Marsupial Frog *Gastrotheca Marsupiata*. *Copeia*. 1989(3): 755-76.
- Kelley, Darcy B. and Donald W. Pfaff. 1976. Hormone Effects on Male Sex Behavior in Adult South African Clawed Frogs, *Xenopus laevis*. *Hormones and Behavior*. 7: 159-181.
- Moore, Frank L. and Pierre Deviche. Neuroendocrine Processing of Environmental Information in Amphibians. Processing of Environmental Information in Vertebrates. M.H. Stetson ed. Springer -Verlag Publishers, New York. 19-45.

Moore, Frank L. 1983. Behavioral Endocrinology of Amphibian Reproduction.

*BioScience*. 33(9): 557-561.

Palka, Yvonne S. and Aubrey Gorbman. 1973. Pituitary and Testicular Influenced

Sexual Behavior in Male Frogs, *Rana pipiens*. *General and Comparative*

*Endocrinology*. 21: 148-151.

Wada, Masura and Aubrey Gorbman. 1977. Relation of Mode of Administration of

Testosterone to Evocation of Male Sex Behavior in Frogs. *Hormones and*

*Behavior*. 8: 310-319.

Wetzel, David M. and Darcy B. Kelley. 1983. Androgen and Gonadotropin Effects of

Male Mate Calls in South African Clawed Frogs, *Xenopus laevis*. *Hormones*

*and Behavior*. 17: 388-404.





Wells, Kentwood D. and Kathleen M. Bard. 1987. Vocal Communication in a

Neotropical Treefrog, *Hyla Ebracatta*: Responses of Females to Advertisement

and Aggressive Calls. *Behavior*. 101(1-3): 200-210.

# Appendix

# Size and Toe Clipping

	T1	T2	T3	T4
right back  ①	4.1cm white w/g	4.7cm grey	4.6cm Grey	4.4cm light green w/green
right back  ②	4cm green w/green	4.4cm green	4cm green	4.5cm light green w/green
front right  ③	4.5cm green	4.2 green w/green	4cm green w/green	<del>4.6cm</del> <del>green w/green</del> lung damage
front right  ④	4cm light g w/g	4.5 grey	4cm grey	4cm green w/green
left back  ⑤	4.6cm green w/green		3.8cm green	4.2cm grey

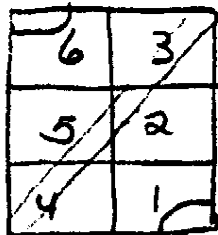

Territory Most Time Spent In

		<u>T1</u>	<u>T2</u>	<u>T3</u>	<u>T4</u>
6/28	1	2 & 4	2 & 1	1 & 2	1
	2	3	4 & 1	3 & 1	4 & 5
	3	4	6	6 & 4	—
	4	4	4	4	4
	5	4	—	6	4
7/1	1	1 & 3	1	4	4
	2	3	1	1 & 3	1
	3	4	4	6	—
	4	4 & 5	4	4	1 & 4
	5	1 & 4	—	3	4
7/4	1	4 & 6	1 & 3	4	4 & 6
	2	1	3	1 & 6	4
	3	4	2 & 4	6 & 4	—
	4	5	4	4	1 & 3
	5	1 & 3	—	3	1 & 6
7/7	1	1 & 3	4 & 6	4	1
	2	1 & 3	3	1, 2, 3	4
	3	4	6	1 & 3	—
	4	4 & 5	4 & 6	1 & 6	4
	5	1 & 6	—	6	6
7/10	1	4	6	6	6
	2	6	6	3	6
	3	6	2	5	—
	4	6	2	6	2
	5	5	—	6	4

	<u>T1</u>	<u>T2</u>	<u>T3</u>	<u>T4</u>
7/31	6	5	1	3
2	6	2	1	3
3	6 & 3	4	1 & 5	-
4	5	2	3	4, 5, 6
5	2	-	4	6

	<u>T1</u>	<u>T2</u>	<u>T3</u>	<u>T4</u>
7/10	1	2 & 3	4	4
2	5	1 & 4	3 & 1	2 & 5
3	4	4	4 & 6	-
4	4	4	3 & 1	1 & 6
5	4	-	6 & 5	5

General Percentages

	<u>T1</u>						<u>T2</u>					
	1	2	3	4	5	6	1	2	3	4	5	6
1	27%	9%	18%	27%	18%	18%	27%	18%	18%	18%	9%	9%
2	25%	37.5%	37.5%	37.5%	37.5%	37.5%	33%	11%	22%	22%	22%	22%
3		12.5%	12.5%	12.5%	12.5%	12.5%	25%		50%	50%	25%	25%
4		4%	4%	4%	4%	4%	11%	11%	22%	44%	11%	11%
5	30%	10%	20%	20%	20%	10%	30%					

	<u>T3</u>						<u>T4</u>					
	1	2	3	4	5	6	1	2	3	4	5	6
1	25%	25%	37.5%	37.5%	37.5%	37.5%	25%		12.5%	37.5%	37.5%	37.5%
2	37.5%	12.5%	12.5%	12.5%	12.5%	12.5%	2	11%	11%	11%	33%	22%
3	12.5%		37.5%	37.5%	37.5%	37.5%	3			11.6%		
4	12.5%	20%	33%	33%	33%	33%	4	25%	8%	41.6%	16.6%	16.6%
5		25%	25%	25%	25%	25%	5	25%		37.5%	12.5%	12.5%

# Territorial Observations

6/25 Arrived 10:25pm No calling  
 warm night - possible storm  
 Active

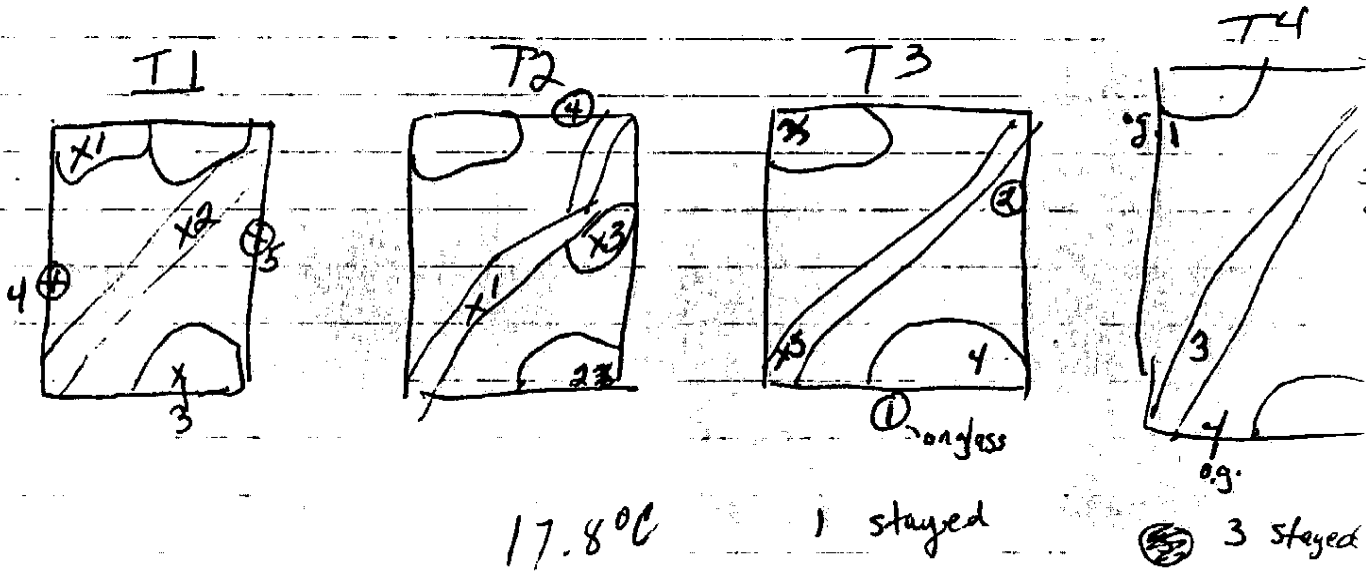

6/27 arrived 9:45pm cool, overcast night no reaction to <sup>Jar</sup> call. <sub>Fro</sub>

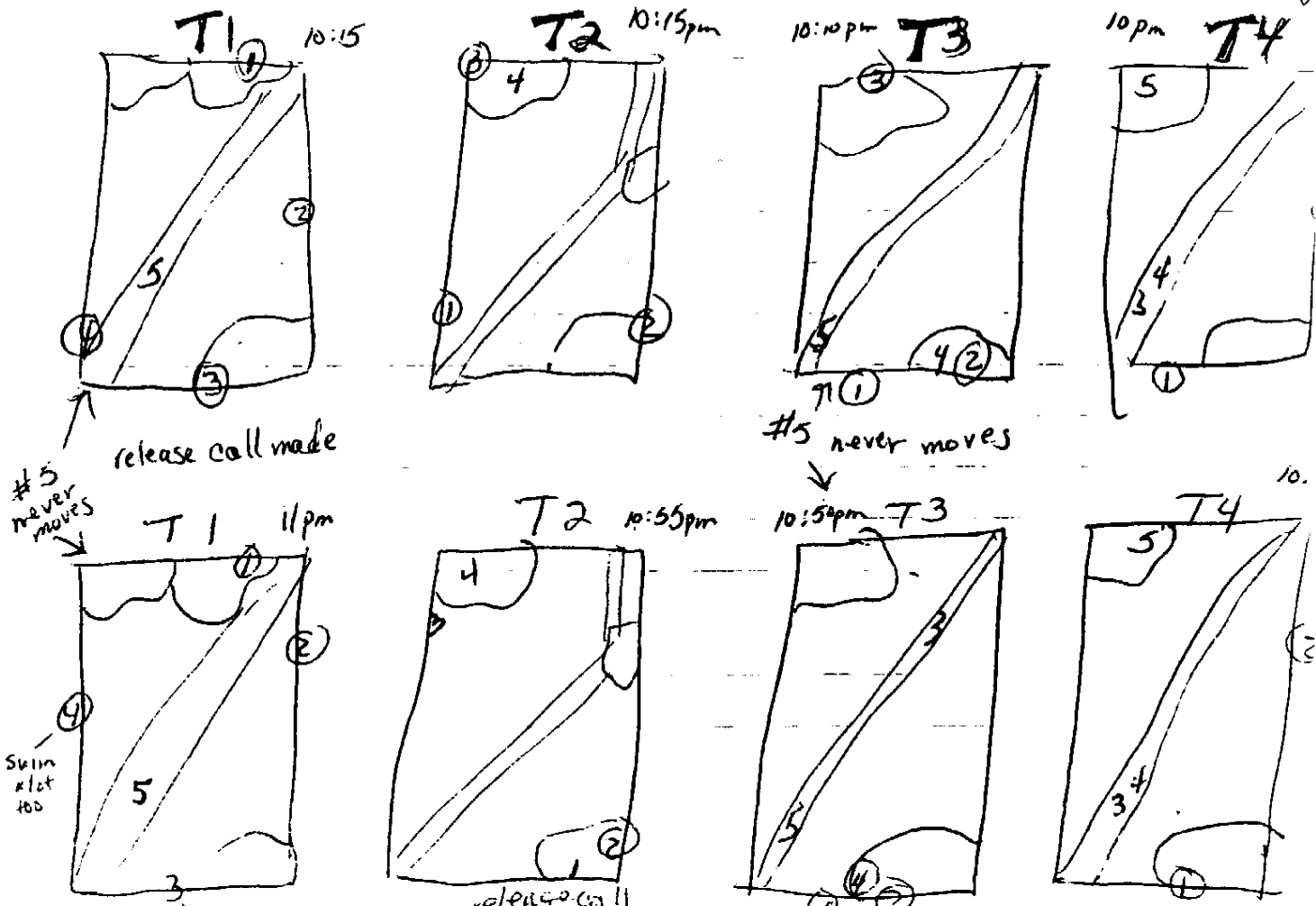

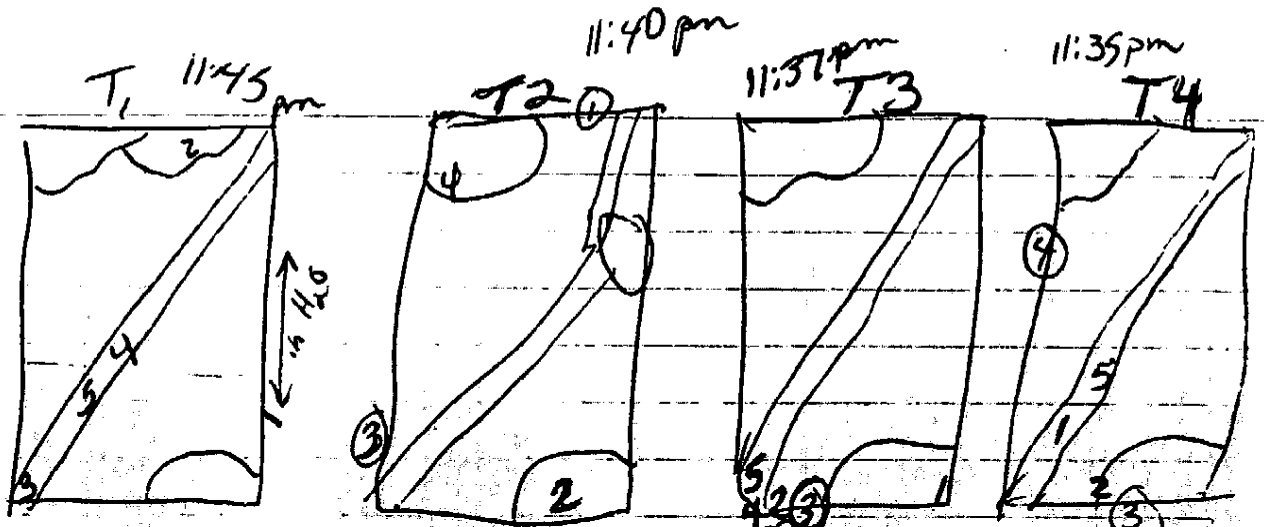

Activity  
very slowed  
in this  
cage, now.  
only #1  
moving  
#1 stopped on sand  
rock

#5 inactive

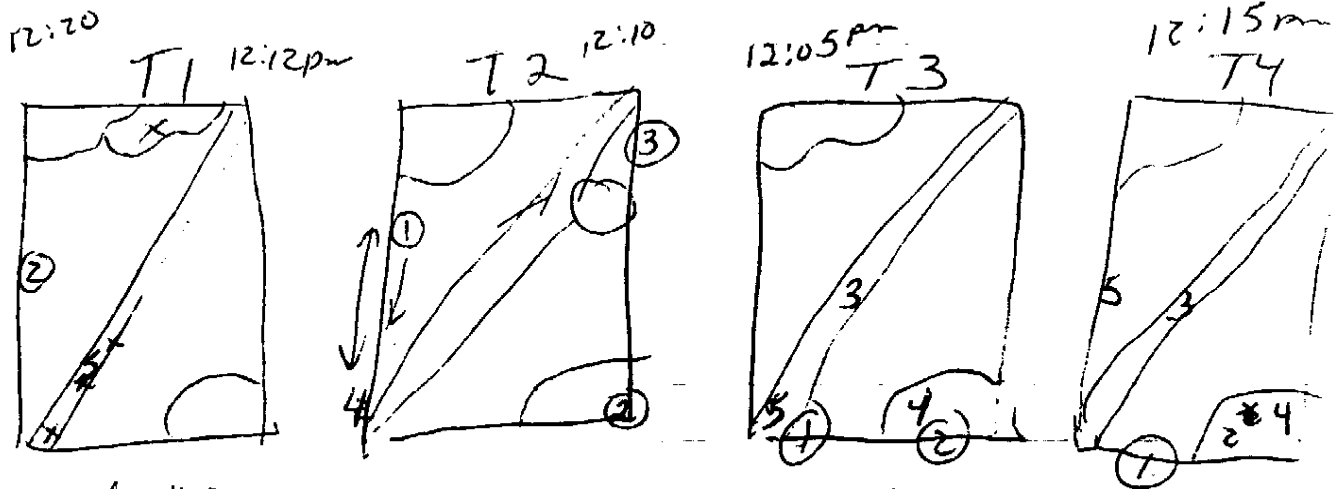

only #2  
active

3 & 5  
inactive

only #1  
active

11.8°C = temp

6/28

overcast 9:20 pm no calling

9:47 pm

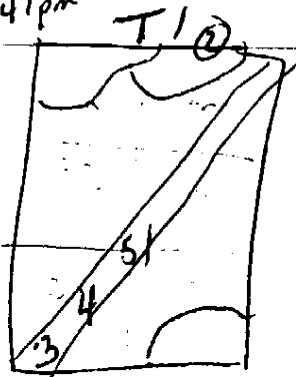

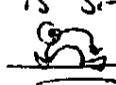
No activity  
but #4  
Keeps opening  
mouth  
& is sitting  
 humped  
up.

9:42

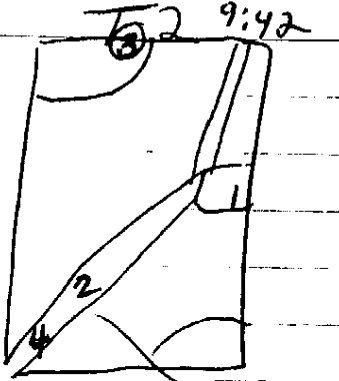

only #3 active

9:37

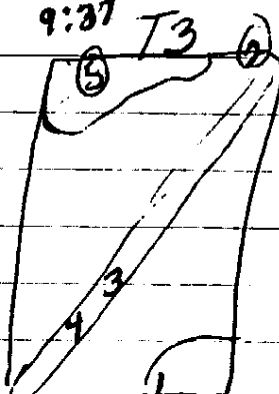

#4 & 3 inactive

9:32 pm

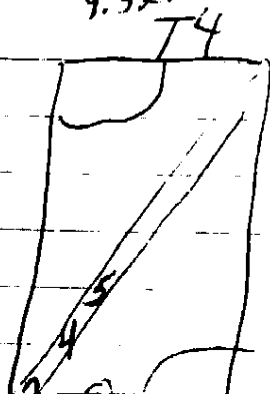

only #1 active

11 pm

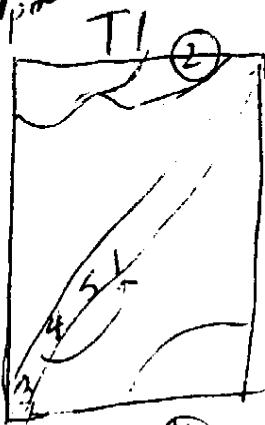

still pretty  
inactive

10:55 pm

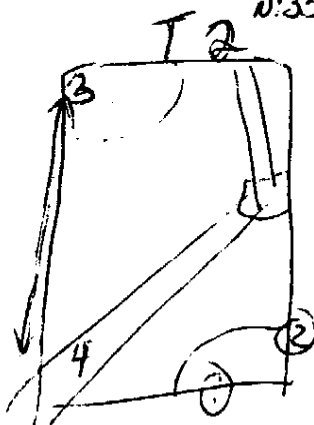

10:50

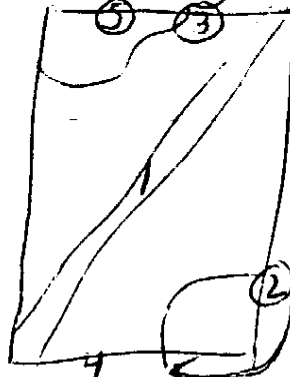

all active  
but #1

10:45 pm

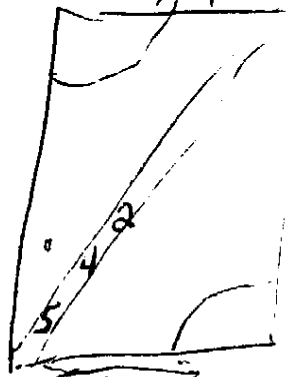

1 m H<sub>2</sub>O  
only #1  
active

7/1

10:20 pm No calling, lots of activity, more release calls heard  
t = 8.900' T1

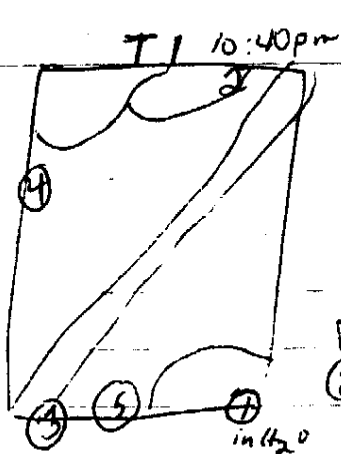

less physical contact w/ each other

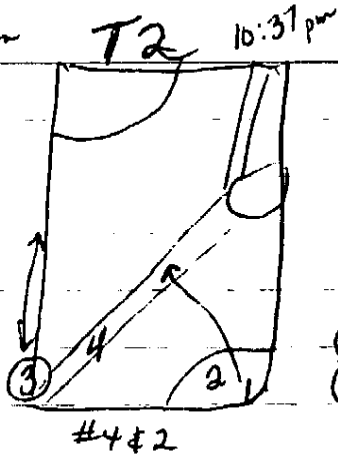

#4 & 2 not very active

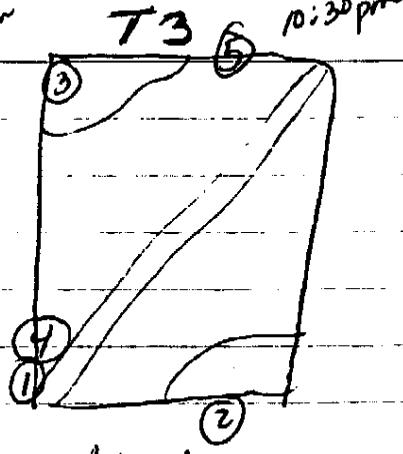

lots of movement

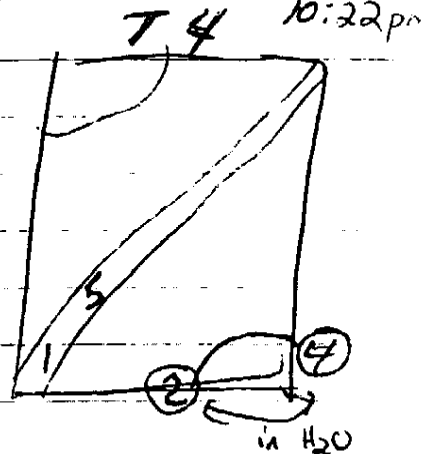

in H2O

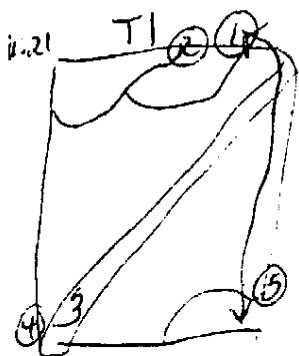

all contact each other

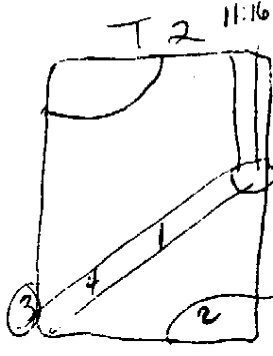

only #3 active

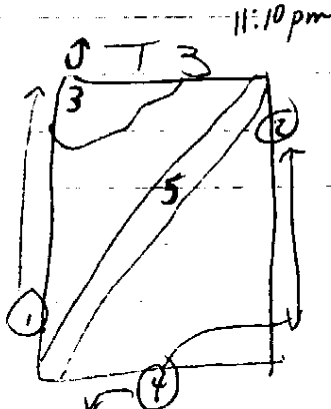

all except 5 active

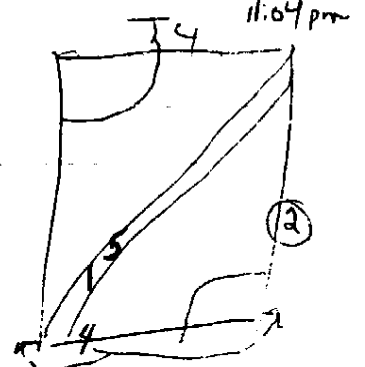

#4 most activity 1 & 5 inactive

7/4

9:45 No calls, clear night

t = 18.9°C

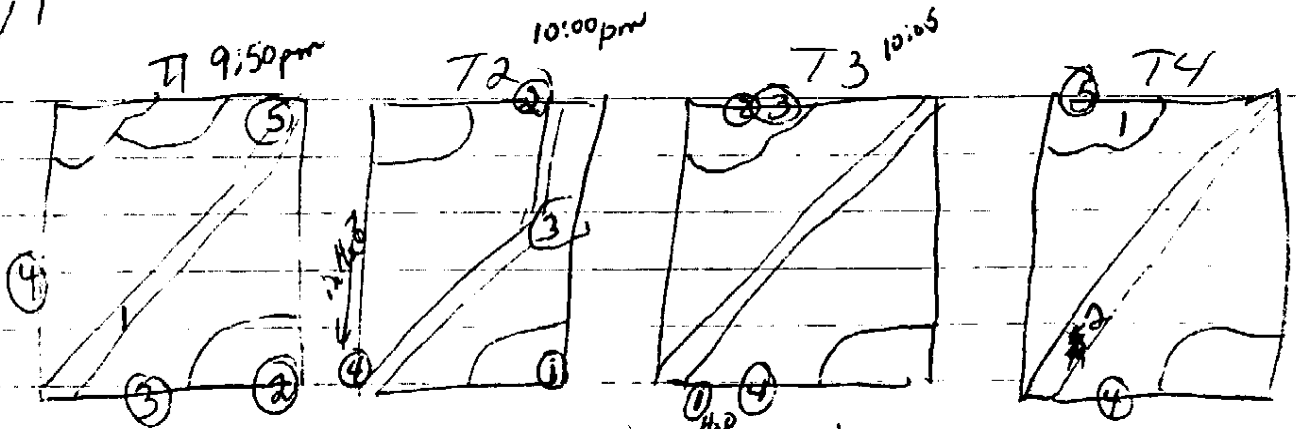

all active but #1

frogs close to each other

#1 has full throat possibly ready to call

release calls 10:15

#2 inactive

more release calls 10:17

" " " 10:45

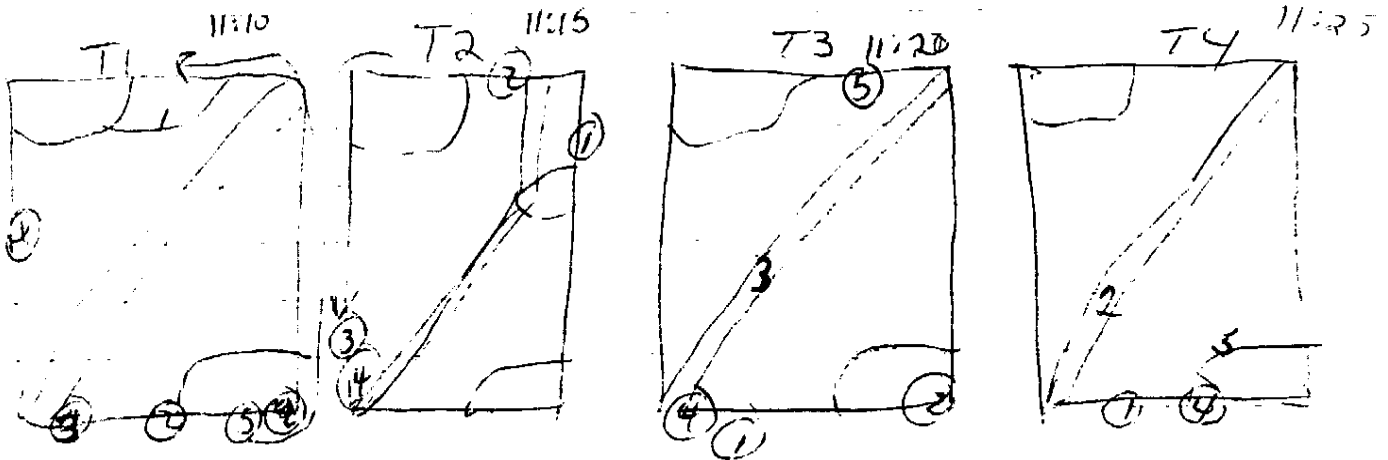

very active do cross territories

active do not move as readily when touch each other

3 not active cross territories touch each other

#4 react quickly to touch by moving away still touch, though

7/7

8:30 pm cloudy & cool  $t = 5.6^{\circ}\text{C}$

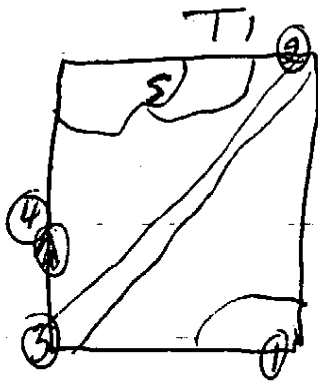

9:05

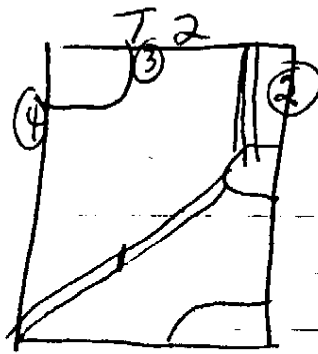

9:00

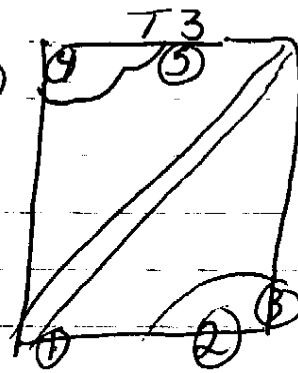

8:50

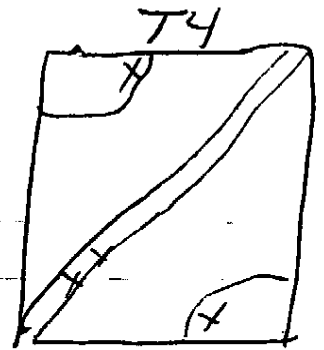

inactive 8:50

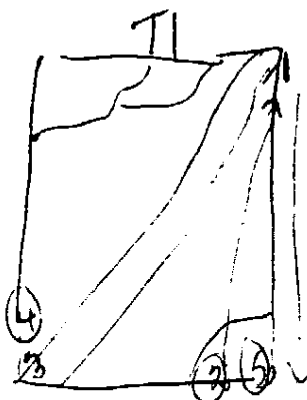

10 pm

#5 pushing each other for corner

then 2 pushed out 1

None remain place long though very active

bunching up at



3 at once not a quick pushing rxn.

release calls in T1

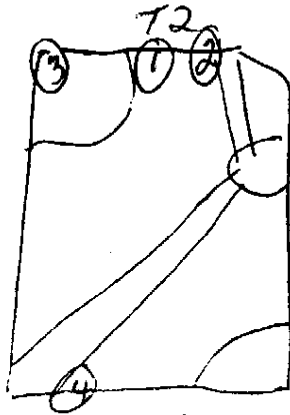

9:45

#4 pushed one out of his corner

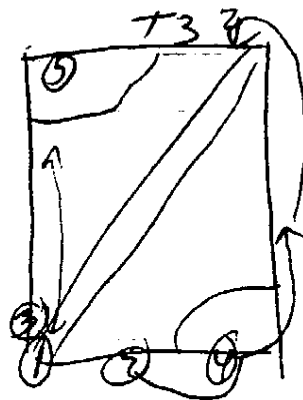

9:42

more avoidance when close, no more pushing

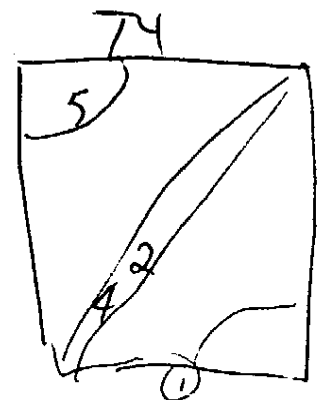

9:37

#1 active only in & out of the

T4 still inactive except #1 at 10:02 p.

7/10 8:20 10°C No sounds, no active yet  
 very cool night

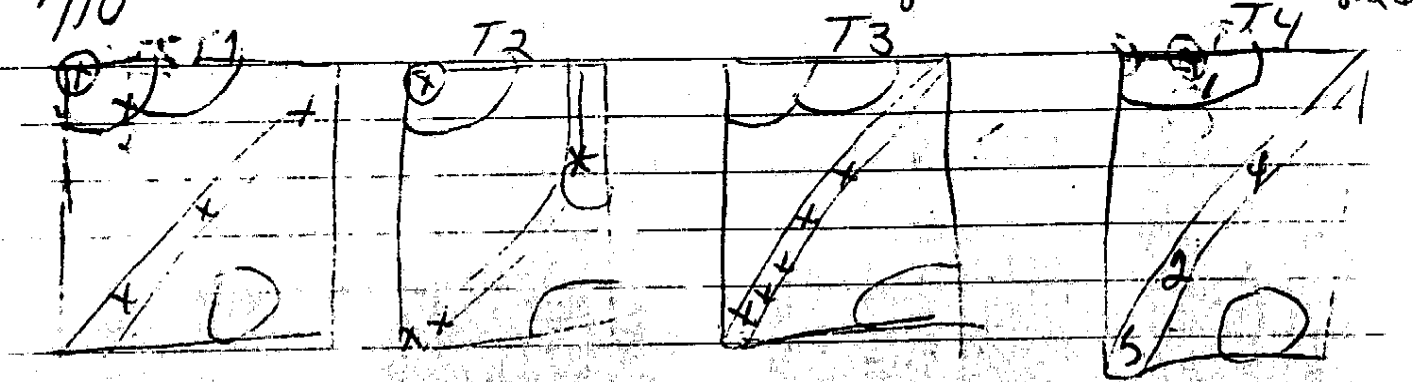

9:20 - no activity yet  
 10:15 - still not very active, most have moved to far end  
 most very close to each other

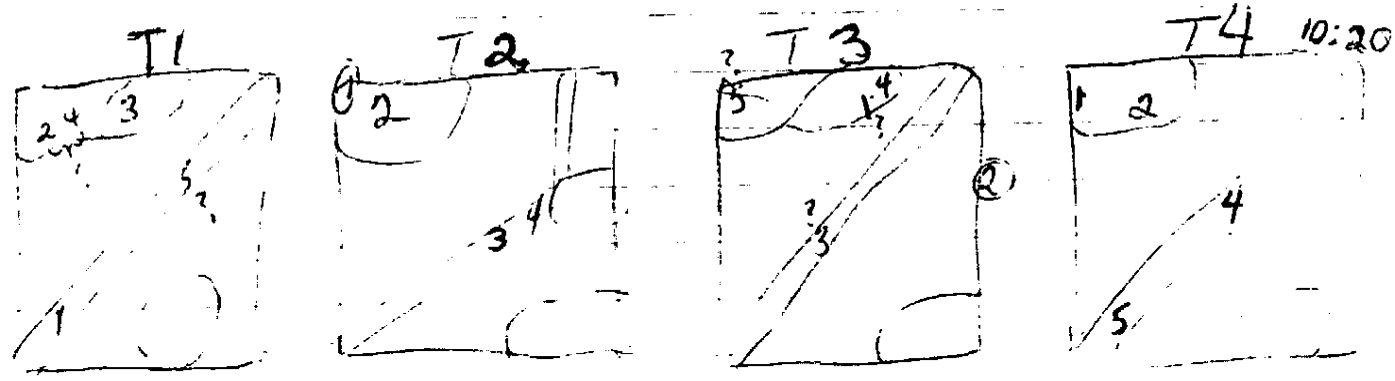

10:40 10:35 10:30 pm

no activity

t = 3.3°C

9 pm activity Activity begins ~ 9:20  
T1 & T4

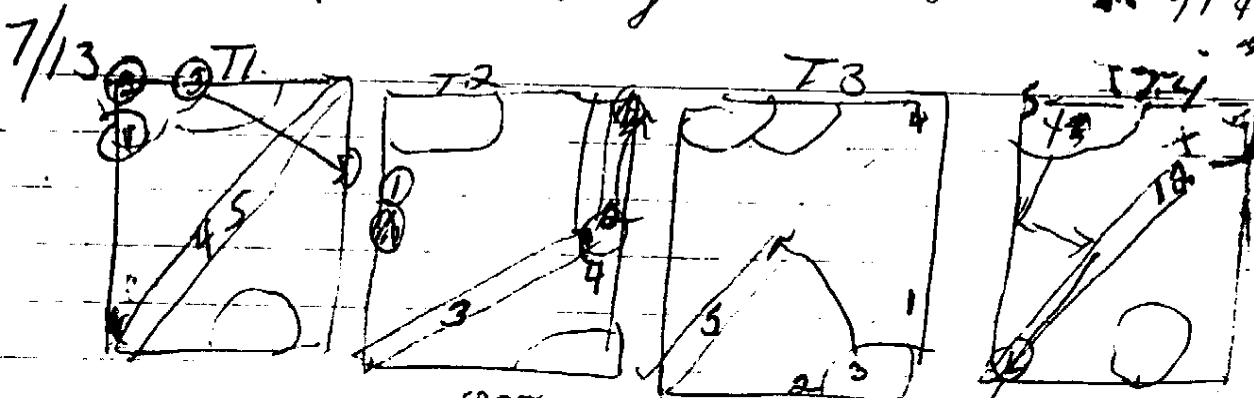

10:40 pm

10:50 pm

10:30 pm

10:05 9:20  
No activ

4 & 2  
are facing  
each other

then 2 jumped up to corner of cage

All cages pretty inactive

4 & 2 become  
somewhat ~~active~~ active  
at 10:55

10 min  
later 4  
follows 2 to  
corner

At 10:55  
1 & 2 move up  
by 4

No aggression  
or pushing

9:40pm active ; warmer night (still cool)

$t = 11.1^{\circ}\text{C}$

7/16

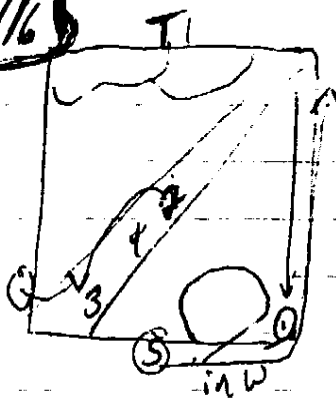

Both 1 & 5 at corner again

2 hopped on 3 while moving

10:15

2 sit on 3 no aggression

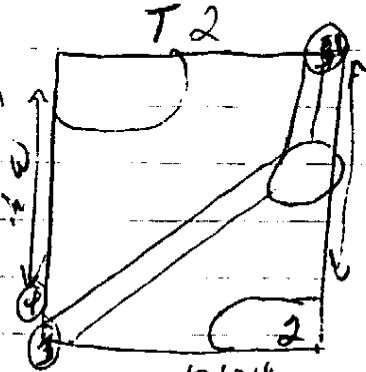

10:04  
Release call  
9:45

only 2 inactive

release call  
short, quiet  
10:37

short release call  
betw. 3 & 4 10:47  
push for corner

Keep pushing often

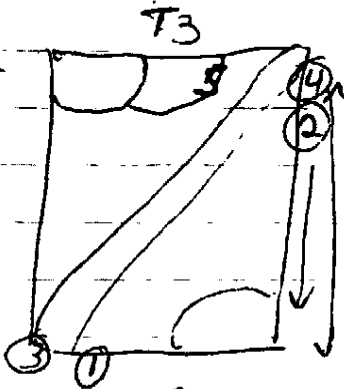

9:50pm  
all active but 5

at least 4  
on front glass  
all the time

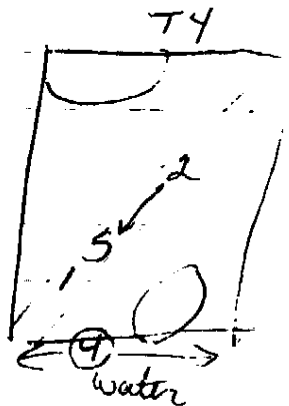

9:50pm  
4 very active  
1 & 5 touch  
1, 5, 2 inactive

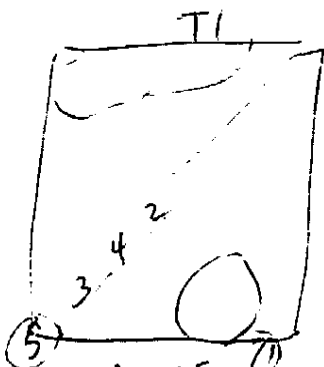

11:35pm  
1 & 5 push for corner

4 & 5  
5 & 2 release call

11:50

5 jumped back to corner

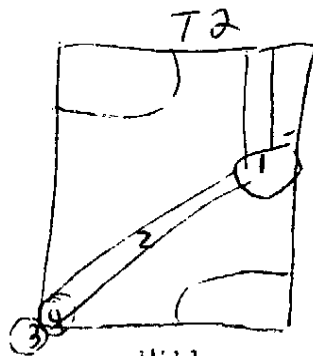

11:33pm  
3 & 4 all active

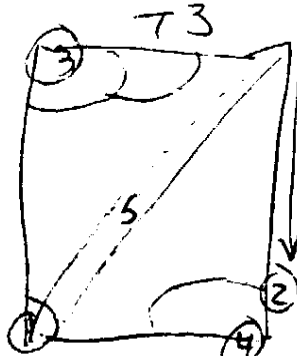

10:27pm  
All active but 5

no pushing

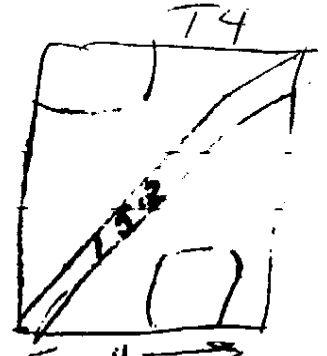

11:25pm