Experiment M10 Remote Control Vehicles Procedure

Deliverables: Checked lab notebook. Race on the south quad on Monday morning!

Overview

Background

In this lab exercise, you will design, build, test, and race remote control vehicles with the overall goal of building a car that can be driven around an outdoor course, a total distance of ~500 ft, in the shortest amount of time. You will use many of things you have learned in the previous lab exercises: DC motors, motor driver boards, remote controls, slotted rail assembly, and driven wheels. Shown below in Fig. 1, there are a wide variety of vehicle design configurations for this lab.

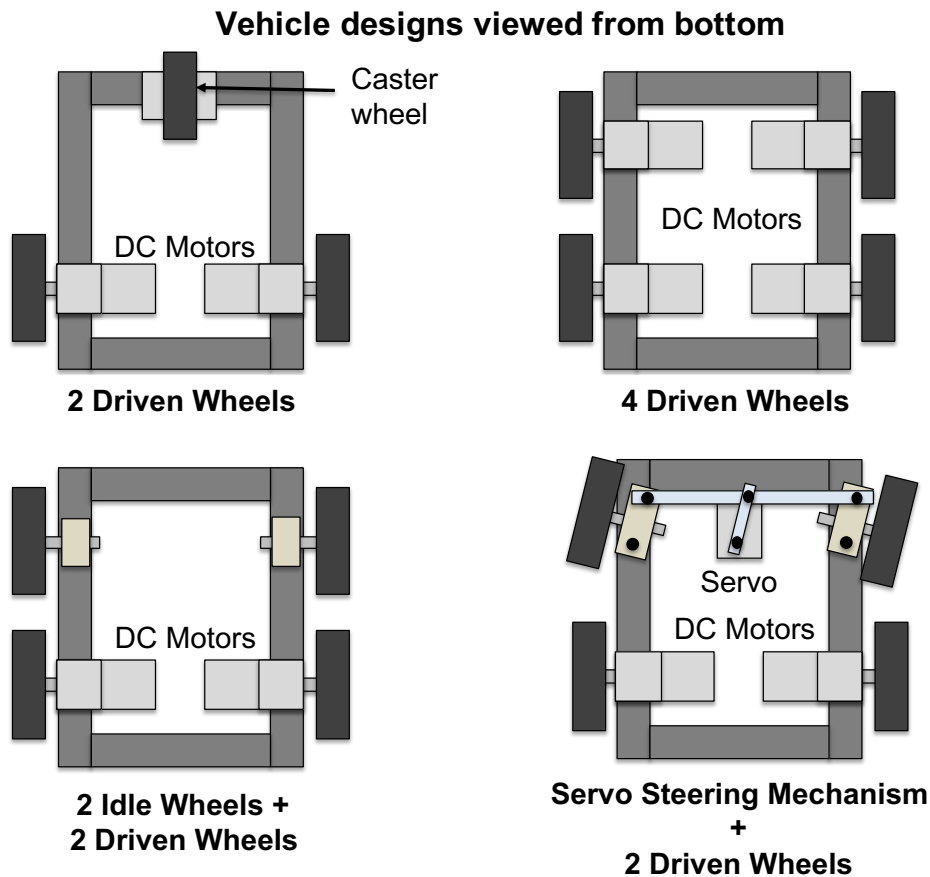

Figure 1 – Four possible vehicle designs include (top left) 2 driven wheels with a single idle caster wheel, (bottom left) 2 driven wheels with two idle wheels, (top right) 4 driven wheels, and (bottom left) two driven wheels with two idle wheels connected to a 4-bar steering mechanism.

Design Decisions

A wide variety of components will be provided in lab for constructing your vehicle, and you will need to make several design decisions.

- Chassis size and wheel-base – Various lengths of 2020 slotted rail
- Motor gear box – No-load speeds of 100, 200, and 550 RPM
- Wheel diameter – $D = 2''$, $2.875''$, $3.875''$, and $4.875''$
- Overall vehicle design configuration – See Figure 1
- Remote control configuration – Human-machine interface (HMI)

Lithium Battery Safety – Standard Operating Procedures

1. Wear safety glasses whenever working with lithium batteries.
2. Inspect all batteries for damage before use. Do not use the battery if:
 - a. The case appears cracked or swollen.
 - b. The external cable insulation is damaged with the inner conducting metal exposed.
3. Charge all LiPo batteries with a proper charger-balancer.
4. Connect the battery to the charger-balancer and verify that all cells have sufficient charge before use.
5. An in-line fuse must be incorporated in any custom circuit that will be connected to a battery. The fuse should be immediately after the battery connector.
6. Do NOT remove the connector from the battery cables. This special connector ensures the battery cannot be accidentally short circuited or connected backward.
7. Lithium batteries should be stored and charged inside a special flame retardant bag or case.

Subsystem A: Electric Powertrain

You will begin by creating the electrical powertrain—the system that distributes electrical power from the battery to the motors.

CAUTION: Lithium batteries pose a serious fire risk. Follow all instructions carefully when building your circuit. Do NOT intentionally modify or damage the battery in any way.

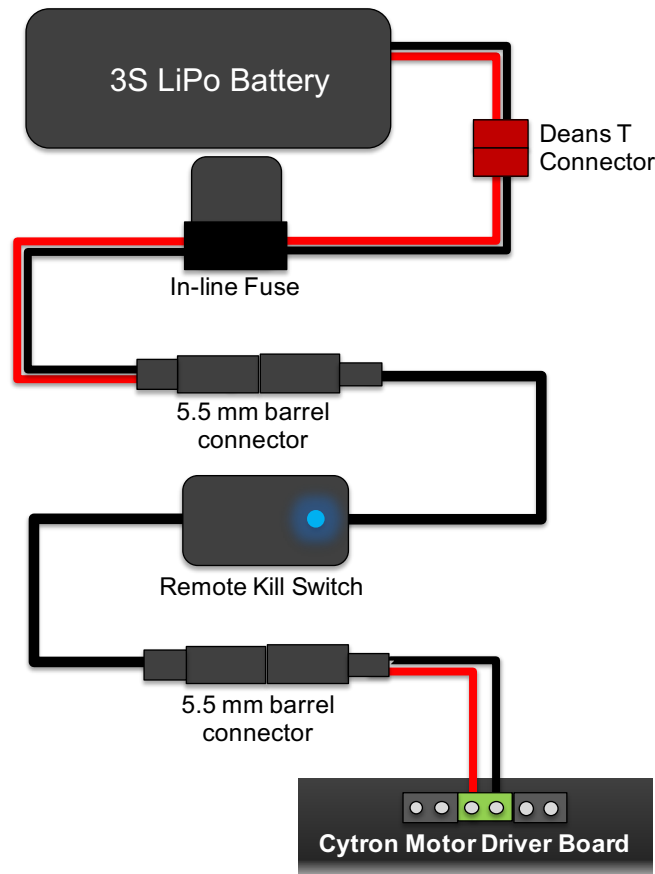

Figure 2 – A 3S LiPo battery is connected to a Cytron dual motor driver board. Between them are a series of safety features that regulate the flow of power.

Safety First: You must wear safety glasses when working with lithium batteries.

Procedure

1. Sketch the system shown in Fig. 2 in your lab notebook.
2. Connect a female 5.5 mm barrel connector to the green screw terminals on the Cytron motor driver board. The red wire goes to the + terminal, and the black wire goes to the – terminal.
3. Locate the 3S LiPo battery. Take it over to the counter top and plug the connector with the four small wires into the battery charger and balancer. You should see all three LEDs light up green, indicating that each of the three cells in the 3S battery are fully charged. If not, ask the lab instructor or TA for help.

4. The red Deans T connector on the battery is our first safety feature. It prevents you from connecting the battery in the reverse polarity, which often results in a short circuit and a fire. Connect the battery to the in-line fuse.
5. The in-line fuse is our second safety feature. It contains a sacrificial metal filament that will melt and break the circuit in the event of a short circuit. Connect the fuse to the remote kill switch via the 5.5 mm barrel connector.
6. The remote kill switch is our third safety feature. It allows the system to be shut down with a small remote control in the event of an emergency.
7. Connect the male end of 5.5 mm barrel on the remote switch to the barrel connector you connected to the motor driver board. The system should now look like Fig. 2.
8. Test the remote kill switch. You should be able to toggle the Cytron motor driver board ON and OFF with the remote key fob.
9. Download the user manual for the Cytron motor driver board from the lab webpage. Read Section 8.1 – RC Input Mode.
10. Connect the any two channels of the RC receiver to the motor driver board, as shown on page 15 of the manual.
11. Choose two motors, both with the same no-load speed. Solder wires to them, and connect them to the motor driver board.
 - a. Solder red and black 20 gage wire to the + and – motor terminals. The wires should be about 10 inches in length. Use the wire strippers in your plastic tote box.
 - b. Seal and protect the solder joints with red and black shrink tubing.
 - c. Connect the motors to the black screw terminals on the motor driver board, as shown on page 15 of the Cytron manual.
12. Turn the system ON with the remote kill switch. Turn ON the RC transmitter, and check that it binds correctly with the receiver.
13. Try using either of the joysticks on the remote control to adjust the speed of the motors.
14. **Demonstrate the working subsystem to the TA, so you can be awarded points on your score sheet.**
15. Use the remote kill switch to turn OFF the electrical powertrain subsystem. Disconnect the motors from the Cytron board. Leave the rest of the subsystem intact, and set it off to the side.

Subsystem B: Chassis and Vehicle Structure

Safety First: You must wear safety glasses when working with lithium batteries.

You will now design (choose parts) and assemble the mechanical structure of your vehicle.

1. Choose a vehicle structure from Figure 1. (We recommend beginning with 2 driven wheels and a caster wheel.) Sketch it in your lab notebook.
2. Design and construct a rectangular chassis out of slotted 2020 rail.
 - a. Choose the dimensions based on the available parts.
 - b. Add the dimensions to the drawing in your lab notebook.
 - c. Attach the pieces using the right-angle brackets and sets screws in the black and orange tackle box on the counter.
3. Fasten the vehicle suspension components to the chassis (motor mounts, caster wheel(s), idle wheels, etc.).
 - a. Use screws and drop-in T-nuts. Sizes M3, M4, and M5 are available. Make sure the screw and T-nut size match.
 - b. Insert T-nuts into the slots sideways. Then, use an allen wrench to push them in, so the rounded side faces down and the flat side faces up.
 - c. The allen wrench can also be used to slide the T-nut to various positions along the slot.
 - d. Add more 2020 rails for additional support, if necessary.
4. Attach the motors you chose to the motor mounts using M3 screws.
5. Attach wheel hubs to the motor shafts.
 - a. Make sure the set screw bites down hard on the flat part of the motor shaft.
 - b. Make sure there is space between the wheel hub and motor.
6. Secure the rubber wheels to the hub. Using the special retaining ring pliers, place a retaining ring on the groove on the hub to secure the rubber wheel in place.
7. Mount a piece of Masonite peg board to the top of the chassis using M5 screws and T-nuts. (You will use this to mount your electrical powertrain in the next part.)
8. Add square plastic endcaps to the ends of the 2020 rails.
9. **Show your fully assembled chassis and vehicle structure to the TA, so you can be awarded points on your score sheet.**

Subsystem C: Remote Controls and HMI

You will now put everything together and program the remote control to steer and drive the vehicle.

1. Use 3M Velcro command strips and zip ties to mount the electric powertrain to the Masonite peg board on top of the chassis.
2. Lift up the vehicle and set the chassis on wood blocks, such that the wheels are not touching the lab bench and are free to spin.
3. Reconnect the DC motors to the Cytron motor driver board and any other wires that may have come loose.
 - a. Refer to the schematic on page 15 of the Cytron manual for details on the wiring.
 - b. Use zip ties to strap down any loose wires.
 - c. Refer to your M7 lab notebook entry to see what channels on the receiver correspond to which knobs and joysticks on the transmitter.
4. Turn on the power and test the remote controlled vehicle. Move the joysticks on the remote control to make the wheels spin.
5. If necessary, adjust the wiring of the receiver and motors so the wheels spin in a logical way corresponding to the controls. Remember, this is the system you will use when you compete in the time trials on Monday.
6. Place adhesive foam corner pads on the corners of your chassis.
7. If you are confident that the remote control is causing the wheels to spin correctly, place the vehicle on the floor and *carefully* drive it around the lab.
8. **Demonstrate your vehicle to the TA by driving it around the lab, so you can be awarded points on your score sheet.**

Design Challenge: Race Day

“If you ain’t first, you’re last!” – Ricky Bobby, *Talladega Nights*

Optimize your vehicle so that it can complete 1 lap around the South Quad race track, a total distance of approximately 520 ft, in under 2 minutes.

Safety First! – Your vehicle must have foam corner pads on the corners of the chassis.

- Take your vehicle out for a test drive. Have the TA or lab instructor come out and time you.
 - You must pass around the outside of the orange cones. You can stay on the sidewalk, or you can cut corners, as long as you stay to the outside of the cones. (Do you even want to cut corners? Is your vehicle strong enough to go off road?)
 - If you can complete a lap in under 2 minutes, you get credit for the design challenge on the score sheet.
 - If not, then that’s when it’s back to the lab again. Rethink your design and make it better.

Clean-up

- Disconnect the RC receiver and battery from the vehicle. Leave the rest of the vehicle intact. You will use it again next week for the M11 – Can Retrieval Vehicle lab. Place the vehicle up in the cabinet above your lab bench.
- Put anything that belongs in your tool kit back into the tote bin.

Data Analysis and Deliverables

You do NOT have to write a tech memo for this lab. Rather, you will need to drive your vehicle around a race track on the South Quad. Only the students who complete 2 laps in less than the average time will receive full credit. (See score sheet.)

Appendix A

Equipment

- 3S LiPo battery, 5200 mAh, fully charged
- 5A In-line fuses with Deans T connectors
- Remote kill switches with key fobs
- Cytron dual motor driver board - SmartDriveDuo-10 MDDS10
- DC motors (greartisan 37mm)
 - 100 RPM
 - 200 RPM
 - 550 RPM
- BaneBots Wheels, Hub Mount, 60A, Black
 - 2" x 0.8"
 - 2-7/8" x 0.8"
 - 3-7/8" x 0.8"
 - 4-7/8" x 0.8"
- BaneBots T81 Hub, 6mm Shaft with retaining rings
- Retaining ring pliers
- Flysky FS-i6X 2.4G 10CH Radio Transmitter and Receiver iA10B – Amazon Part # B0B3T2R65X
- 2020 T-slot rail, various lengths
- Fasteners for 2020 T-slot rail
- Caster wheels
- Pillow block bearings for 6mm shafts
- 6 mm steel shafts
- Tape measure