

Experiment A6 Solar Energy II Procedure

Deliverables: checked lab notebook, **Full Lab Report**

Overview

This week, you will create your own “Solar Microgrid”. The microgrid consists of the solar panel, a 12V lead acid battery, and a charge controller, as shown below in Figure 1. Solar panels obviously do not produce energy at night, so the 12V battery is used to store energy produced during the day. Directly connecting ~20V DC output of the solar panel to charge the 12V battery would damage it, so the charge controller is used to step down the 20V DC to 12V DC. Additionally, the charge controller contains two 5V USB outputs for charging and powering various consumer electronics.

For your midterm lab report, you will independently design a solar microgrid for a custom camper van.

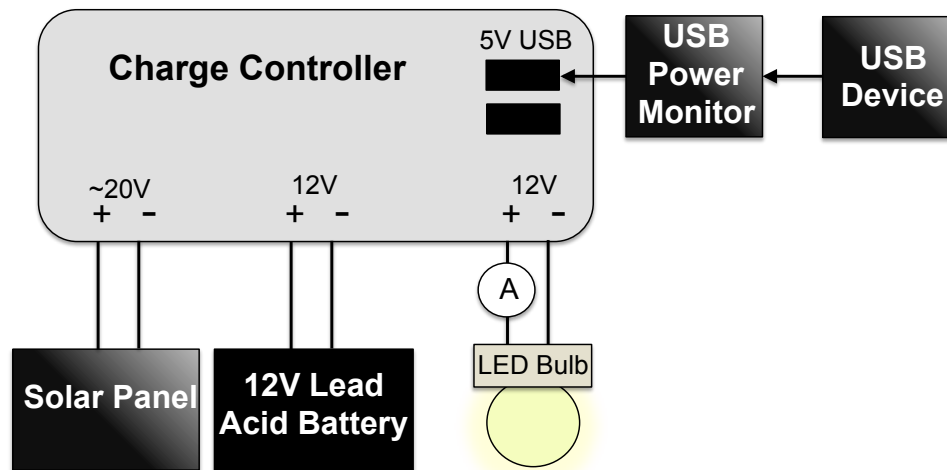

Figure 1: A schematic of the Solar Microgrid.

Part I – Constructing a Microgrid

Procedure

1. Sketch the schematic shown in Figure 1 in your lab notebook.
2. Connect the solar panel to the input terminals on the far left of the charge controller:
 - a) Loosen the two terminal screws on the top of the charge controller.
 - b) Use the female banana cables with stripped wire on the end.
 - c) Twist the stripped end of wire to tidy it up, insert it into the side of the charge controller, and tighten the screw to lock it in place.

3. Place the solar panel directly under the lamp, and set the variac to 120 V.
4. Connect the battery to the charge controller:
 - a) Loosen the two terminal screws on the top of the charge controller.
 - b) Use the “spade connectors” with stripped wire on the ends. Insert the stripped end of each wire on the side of the charge controller and tighten the screws to lock them in place.
 - c) Place the spade connectors on the battery.

Caution: This is a powerful battery. It is NOT a toy. It can cause painful shocks, burns, and even cause fires.

5. Check that the battery is securely connected to the screw terminals of the charge controller.
6. Look at the screen on the charge controller. What do you see? Flip the panel upside-down. Does the screen on the charge controller change? Sketch the screen in your lab notebook.
7. Flip the panel right-side up again.
8. Place the LED bulb upside down in the metal Bunsen burner stand.
9. Connect the LED light bulb to the 12V DC output terminal of the charge controller:
 - a) Insert a length of wire into the 12V “+” output screw terminal.
 - b) Locate the handheld DMM with mini-grabber cables in the 10A socket. Connect one of the DMM cables to the wire in the charge controller. Connect the other DMM cable to the red light bulb wire, such that the DMM is **in series** with the LED bulb, as shown in Figure 1. Switch the DMM knob to the 10A current setting. **Caution: You must use the 10A setting, or you will burn out the DMM!**
 - d) Connect the other light bulb wire to the negative screw terminal on the charge controller.
 - e) Turn on the LED bulb, and you should see a value for the current on the multimeter.
10. Locate the DMM with the pointy metal probes. Make sure the clicker knob is set to measure DC voltage. Measure the **voltage** across the screw terminals on the bottom of the LED bulb. Turn off the LED bulb.
11. Plug the USB power monitor stick into one of the USB charging ports. Choose a USB device and plug it into the other end of the USB power monitor. (Possible devices include your cell phone or tablet or the rechargeable flashlight or fan provided by Prof. Ott.)
12. Use the USB power monitor to measure the voltage and current of the USB device.
13. Copy Table 1 into your notebook. Fill it out by recording the current for the LED bulb and current and voltage for two different USB devices. (Be sure to write down the actual names of the USB devices you used, not just “USB Device 1”.) Put the solar panel directly under the lamp to simulate day and turn it upside down to simulate night. **Demonstrate this to the lab instructor or TA.**
14. When you are all finished, **turn the variac dial back to zero and turn off the variac.** Turn off the LED bulb and disconnect the handheld DMMs. Disassemble everything. Return everything to the plastic case, except for the battery.

Table 1: Energy usage of various electronic devices.

	USB Device 1		USB Device 2		LED Bulb	
	Voltage	Current	Voltage	Current	Voltage	Current
Day						
Night						

Part II – Designing a Solar Microgrid for a Custom Camper Van

In your lab report, you will present a preliminary design of a rooftop solar microgrid for a custom camper van. Each student will be randomly assigned a vehicle (van), location, and several devices that need to be powered by the solar system. You will have to choose the number of solar panels based on the size of van roof. Then, you will need to select a charge controller and batteries with the capacity to store half a day’s worth energy produced by the panels. Lastly, you will compute the average daily power output of the system and determine if each individual device could feasibly be powered by the system.

Procedure

1. Do a bit of online research, and write down the following parameters. Be sure to bookmark your sources, as you will need to reference them in your report.
 - a. What are the dimensions of the roof of the vehicle?
 - b. What is the average solar irradiance in kWhrs/day/m² at the given location?
 - c. What are the typical voltage requirements for each of the devices (i.e. 5V DC, 120V AC, etc.)?
 - d. What are the typical current requirements for each of the devices (i.e. 10 Amps, etc.)?
 - e. What is the typical instantaneous power in kW needed to power each of the devices?
2. Choose a solar panel from one of the preferred vendors. Write down its cost, efficiency, and surface area. (You might have to do a bit of digging to get the technical specifications, but that’s just part of the job!)
 - a. Use the average irradiance of your given location, the area of the solar panel, and its efficiency to calculate the average amount of energy a single solar panel would output in kWhrs/day.
 - b. How many solar panels could fit on the roof of the vehicle? Compute the *total* power output of the panels in kWhrs/day.
3. Choose a battery from the same vendor as the solar panel. Write down its cost, voltage, and charge capacity in Amp-hrs.
 - a. What is the total amount of energy it can store in kWhrs?
 - b. How many of these batteries would you need to store half a day’s worth of energy output by the solar panels?

4. Choose a charge controller and AC power inverter from the same vendor. (They may be separate or a 2-in-1 device.) Check the input power ratings to make sure it is capable of handling the power produced by the solar panels. Check the output power rating to make sure it will be able to power the devices. Be sure to write down its cost.
5. Estimate a typical average daily usage of each device (in hrs/day). Multiply the average daily usage by the instantaneous power to obtain the average daily power consumption for each device (in kWhrs/day). Then, use your engineering judgement to decide if it is even feasible to include this device in the camper van.

Preferred Vendors:

Northern Arizona Wind & Sun - <http://www.solar-electric.com/>

Solar Electric Supply, INC. - <http://www.solarelectricsupply.com/>

Wholesale Solar - <http://www.wholesalesolar.com/>

Week II Deliverables – Download the LaTeX or MS Word template from the course website and use it to write a brief lab report, no longer than **8 pages**. You are required to include the following items in your lab report **along with the deliverables from the previous week**. (See the score sheet for points.)

1. A table summarizing the calculations for the size and number of solar panels and batteries you will need. (Be sure to include references.)
 - a. The approximate size (area) of the vehicle roof in m^2 .
 - b. The number of solar panels that can fit on the vehicle roof.
 - c. The total area of the solar panels you chose in m^2 .
 - d. The average irradiance in kWhrs/day/ m^2 at the given location.
 - e. The percent efficiency of the solar panels you chose.
 - f. The total average power in kWhrs/day you expect all the solar panels to output at your given location.
 - g. The energy storage capacity of the battery you chose.
 - h. The number of batteries needed to store half a day's worth of energy from the panels.
2. A table containing the following parameters for your devices. (Be sure to include references.)
 - a. The typical voltage requirements for each of the devices. (i.e. 5V DC, 120V AC, etc.)
 - b. The typical current requirements for each of the devices. (i.e. 10 Amps, etc.)
 - c. The typical instantaneous power in kW for each device.
 - d. The estimated daily usage of each device in hours/day.
 - e. The estimated average daily power consumption for each device.
 - f. State whether each device is "Feasible" or "Not Feasible" to include in the camper van.

3. A table containing a bill of materials (BOM) for the parts you chose from one of the preferred vendors.
 - a. Solar panels, their part number, individual cost, quantity, and total cost in USD.
 - b. Batteries, their part number, individual cost, quantity, and total cost in USD.
 - c. Charge controller, its part number, individual cost, and total cost in USD.
 - d. Power inverter to convert the DC voltage from the batteries to an AC voltage for the appliances (if necessary), its part number, individual cost, and total cost in USD. (If you chose a 2-in-1 charge controller and power inverter, then only include this device in your BOM.)
 - e. The total cost of the system.

Suggested Talking Points – This lab is to test your ability to work *independently*, so these are merely *suggestions*. Feel free to be as creative as possible in your analysis.

- Write a few paragraphs describing the microgrid, its location, what devices it powers, the vendor, its components, how much power it produces, etc.
- Discuss the economic feasibility of the microgrid. Look up the cost of electricity in USD/kWhr at the given location. Based on the average power output by the solar panels, how many years would it take the microgrid to pay for itself? Compared to the average lifetime of the components, does it make sense to build the microgrid in the given location?

Appendix A

Extra Equipment Available for Independent Experiment

- Solar Panel w/ 24" wire leads ending in male banana connector
- Multi-meter w/ 24" wire leads ending in male banana connector
- BK Precision AC Power Supply
- Halogen lamp Fixture w/ GE Lamp: GE 90w 1900lm M/N 66286 PAR 38
- Extech handheld digital multimeters with minigrabber cables
- Extech handheld digital multimeters with probe cables
- 2 BNC to banana adapters
- Set of banana cables (1 black, 1 red)
- Black plastic case containing Micro-grid
 - Mohoo 20A Charge Controller Solar Charge Regulator Intelligent USB Port Display 12V-24V
 - Eversame USB Digital Power Meter Tester Multimeter Current and Voltage Monitor, DC 5.1A, 30V
 - ExpertPower EXP1272 12V 7.2 Amp-hour Rechargeable Battery
 - ChiChinLighting 12v LED Bulb Daylight AC DC Compatible 7 Watts 6000k Low Voltage
 - Porcelain Medium-Base Light Bulb Socket with Pull Switch, 250 Maximum Watts, 250 Maximum Volts
 - Bunsen burner stand
 - USB device (fan or flash light)
 - Small flathead screw driver
 - Female banana cables with stripped wire end (1 black, 1 red)
 - Black battery wire with spade connection
 - Red battery wire with spade connection and 2A fuse
 - 18 AWG wires with stripped ends (black and red)