

2.

E. L. Leavitt, Jr.
1860.

A MANUAL
OF THE
STEAM ENGINE,
AND OTHER
PRIME MOVERS.

Professor Rankine's
SERIES OF PRACTICAL MANUALS
ON
CIVIL ENGINEERING AND MECHANICS.

Crown 8vo.

In course of Publication.

APPLIED MECHANICS,

COMPRISING

**PRINCIPLES OF STATICS, CINEMATICS, AND DYNAMICS, AND THEORY OF STRUCTURES,
MECHANISM, AND MACHINES.**

With numerous Illustrations, price 12s. 6d.

**THE STEAM ENGINE,
AND OTHER PRIME MOVERS.**

With numerous Tables and Illustrations, price 12s. 6d.

CIVIL ENGINEERING;

COMPRISING

**ENGINEERING SURVEYS, EARTHWORK, FOUNDATIONS, MASONRY, CARPENTRY, METAL-
WORK, ROADS, RAILWAYS, CANALS, RIVERS, WATER-WORKS, HARBOURS, &c.**

With numerous Tables and Illustrations.

MACHINERY AND MILL WORK;

COMPRISING

**GEOMETRY OF MACHINES, MOTIONS OF MACHINES, WORK OF MACHINES, STRENGTH OF
MACHINES, CONSTRUCTION OF MACHINES, OBJECTS OF MACHINES, &c.**

With numerous Tables and Illustrations.

USEFUL RULES AND TABLES

FOR

**ARCHITECTS, BUILDERS, CARPENTERS, ENGINEERS, FOUNDERS, MECHANICS,
SHIPBUILDERS, AND SURVEYORS.**

o A MANUAL
OF THE
STEAM ENGINE
AND OTHER
PRIME MOVERS.

BY

WILLIAM JOHN MACQUORN RANKINE,

CIVIL ENGINEER; LL.D.; F.R.SS. LOND. AND EDIN.; F.R.S.S.A.;

REGIUS PROFESSOR OF CIVIL ENGINEERING AND MECHANICS IN THE UNIVERSITY OF GLASGOW;

PAST PRESIDENT OF THE INSTITUTION OF ENGINEERS IN SCOTLAND; VICE-PRESIDENT

OF THE PHILOSOPHICAL SOCIETY OF GLASGOW; HONORARY MEMBER OF THE

LITERARY AND PHILOSOPHICAL SOCIETY OF MANCHESTER, OF THE

ROYAL SOCIETY OF TASMANIA, ETC., ETC.

With Numerous Diagrams.

LONDON AND GLASGOW:
RICHARD GRIFFIN AND COMPANY,
Publishers to the University of Glasgow.

1859.

[The Author reserves the right of Translation.]

Eng 2698.59
18

Harvard College Library

Aug. 14, 1916.

Bequest of

Erasmus Darwin Leavitt. B

P R E F A C E.

THE purpose of this book is to explain the scientific principles of the action of "PRIME MOVERS," or machines for obtaining motive power, and to show how those principles are to be applied to practical questions.

It has been deemed advisable to prefix to the Treatise a very brief Historical Sketch, relating chiefly to the Steam Engine, the only prime mover whose history is known.

The body of the work commences with an Introduction, treating of principles, and of mechanical contrivances, which are common to all prime movers, and of the laws of the strength of materials, so far as they are applicable to those machines. Some passages in the Introduction are extracted from a previous Treatise on *Applied Mechanics*, and abridged or amplified as may be required, in order to suit the purpose of the present Treatise. Such passages are indicated by the letters *A. M.*, with a reference to the number of the corresponding Article in that work.

The first part following the Introduction treats of the use of muscular strength to obtain motive power.

The second part treats of prime movers driven by the motion of water and of air, including water-pressure engines, waterwheels, turbines, and windmills.

The third and largest part treats of engines driven by the mechanical action of heat, and especially of the steam engine. It explains, in the first place, the phenomena of heat, so far as they affect, directly or indirectly, mechanical action in engines; secondly, the laws of combustion and properties of fuel, and the principles upon which economy of fuel depends; thirdly, the laws of the action of heat in producing motive power, or "PRINCIPLES OF THERMODYNAMICS," as applied to the various engines in which that action takes place, and especially to steam engines of all varieties; fourthly, the nature and action of the parts of furnaces and boilers; fifthly, the nature and action of the mechanism of steam engines.

The fourth part explains the principles of the action of electro-

magnetic engines; but very briefly, in consideration of their small importance as prime movers, and absence of economy; the true practical use of electro-magnetism being, not to drive machinery, but to make signals; and the subject of telegraphy being foreign to the purpose of this work.

The principles of thermodynamics, or the science of the mechanical action of heat, are explained in the third chapter of the third part more fully than would have been necessary but for the fact, that this is the first systematic treatise on that science which has ever appeared; the only previous sources of information regarding it being detached memoirs in the transactions of learned societies, and in scientific journals.

The experimental and practical examples used to illustrate the application of the principles of that science, and of rules and tables deduced from them, are, to a considerable extent, taken from the Author's personal observations of the performance of marine engines.

At the end of the book, as well as interspersed through it, are various tables, useful in calculations respecting prime movers, especially the steam engine; and many of those tables contain results which have never before been published.

The Author has endeavoured to the best of his ability and recollection to acknowledge, in the course of the book, the sources from which he has derived information. For much of that information, for opportunities of inspecting furnaces, boilers, and engines, making experiments, and in some cases for drawings of engines, which have been reduced to a small scale to illustrate this work, he has now to return his most grateful thanks to many engineers, shipbuilders, manufacturers, and men of science; and amongst them to PROFESSOR WEISBACH; M. DU TREMBLEY; MR. JAMES R. NAPIER; MR. FAIRBAIRN; DR. JOULE; DR. WILLIAM THOMSON; PROFESSOR JAMES THOMSON; MESSRS. NEILSON & Co.; MESSRS. CHARLES TENNANT & Co.; MESSRS. R. NAPIER & SONS; MESSRS. RANDOLPH, ELDER, & Co.; MESSRS. ROWAN & Co.; MESSRS. CAIRD & Co.; MESSRS. A. MORE & SON; MESSRS. KITSON, THOMPSON, & HEWITSON; MESSRS. DUNN, HATTERSLEY, & Co.; MESSRS. JOHN REID & Co.; MESSRS. SCOTT & Co.; MESSRS. HENDERSON & SON; THE LANCEFIELD FORGE COMPANY; and many others.

CONTENTS.

	Page
HISTORICAL SKETCH, RELATING CHIEFLY TO THE STEAM ENGINE,	xv
INTRODUCTION,—OF MACHINES IN GENERAL.	
SECTION 1.—Of Resistance and Work.	
Art.	Page
1. Action of a Machine,	1
2. Work, its definition and measures,	1
3. Rate of Work—Horse-power,	2
4. Velocity,	2
5. Work in Terms of Angular Motion,	3
6. Work in Terms of Pressure and Volume,	4
Table of Units of Pressure,	5
7. Algebraical Expressions for Work,	5
8. Work against an Oblique Force,	6
9. Summation of Quantities of Work, Reduction of Resistance to Driving Point,	6
10. Representation of Work by an Area,	7
11. Work against varying Resistance,	8
11 A. Approximate Computation of Integrals,	9
12. Useful Work and Lost Work,	11
13. Friction,	13
14. Unguents,	14
14 A. Work of Acceleration—Mass—Momentum,	16
15. Summation of Work of Acceleration—Moment of Inertia—Inertia reduced to Driving Point,	18
16. Summary of various kinds of Work,	21
SECTION 2.—Of Deviating and Centrifugal Force.	
17. Deviating Force of a Single Body,	24
18. Centrifugal Force,	25
19. Revolving Pendulum,	26
20. Deviating Force in Terms of Angular Velocity,	26
21. Resultant Centrifugal Force,	27
22. Centrifugal Couple—Permanent Axis,	27
SECTION 3.—Of Effort, Energy, Power, and Efficiency.	
23. Effort,	30
24. Condition of Uniform Speed,	31
25. Energy—Potential Energy,	31
26. Equality of Energy exerted and Work performed,	32
27. Various Factors of Energy,	32
28. Energy exerted in Acceleration,	33
SECTION 4.—Of Dynamometers.	
29. Accelerating Effort,	33
30. Work during Retardation—Energy Stored and Restored,	35
31. Actual Energy,	35
32. Reciprocating Force,	36
33. Periodical Motion,	36
34. Starting and Stopping,	37
35. Efficiency,	38
36. Power and Effect—Horse-power,	38
37. General Equation and Principle,	40
SECTION 5.—Of Brakes.	
38. Dynamometers defined and classed,	40
39. Prony's Friction Dynamometer,	41
40. Morin's Traction Dynamometer,	42
41. Morin's Rotatory Dynamometer,	42
42. Integrating Dynamometers,	45
43. Indicator—Application to the Steam Engine,	46
44. Indicator—Other Applications,	47
SECTION 6.—Of Fly Wheels.	
45. Brakes Defined and Classed,	52
46. Action of Brakes in general,	52
47. Block Brakes,	53
48. Brakes of Carriages,	53
49. Flexible Brakes,	54
50. Pump Brakes,	54
51. Fan Brakes,	56
SECTION 7.—Of Fly Wheels.	
52. Periodical Fluctuations of Speed,	58
53. Fly Wheels,	61
SECTION 8.—Of Regulators and Governors in general.	
54. Regulators,	62
55. Pendulum Governors,	63
56. Balanced Governors,	63
57. Fan Governors,	63
SECTION 9.—Summary of Principles of the Strength of Machines.	
58. Nature and Division of the Subject,	64
59. Factors of Safety,	64
60. Proof or Testing,	65
61. Tenacity of Bars,	65
62. Cylindrical Boilers and Pipes,	66
63. Spherical Shells,	67
64. Thick Hollow Cylinder,	68
65. Thick Hollow Sphere,	68

SECTION 8.—*Summary of Principles of the Strength of Machines—continued.*

Art.	Page	Art.	Page
66. Boiler Stays,	69	72. Strength of Timber Posts, Struts, and Connecting Rods,	74
67. Cylindrical Flues,	70	73. Resistance to Cross Breaking,	75
68. Elliptical Flues,	71	74. Resistance to Wrenching.—Axles,	78
69. Shearing Force of Keys, Pins, Bolts, and Rivets,	71	75. Twisting and Bending combined,	79
70. Resistance to direct Crushing,	72	76. Teeth of Wheels,	80
71. Resistance of Iron Rods and Pillars to Crushing by Bending,	78	SECTION 9.— <i>Prime Movers Classed,</i>	80

PART I.—OF MUSCULAR POWER.

CHAPTER I.—GENERAL PRINCIPLES.

78. Nature of the Subject,	81	Time of Working, on Daily Work,	82
79. Daily Work—Circumstances affecting it,	81	81. Influence of other circumstances—Race, Food, Air, &c.,	82
80. Influence of Load, Velocity, and		82. Transport of Loads,	88

CHAPTER II.—POWER OF MEN.

83. Tables of the Performance of Men,	84	85. Lifting Weights by a Rope,	86
84. Work of a Man raising his own Weight,	85	86. Other modes of Exertion,	86
		87. Transporting Loads,	87

CHAPTER III.—POWER OF HORSES AND OTHER BEASTS.

88. Tables of the Performance of Horses,	88	90. Horse Gin,	89
89. Oxen, Mules, Asses,	89	91. Treadwheels for Horses and Oxen, —(See <i>Appendix</i>),	89

PART II.—OF WATER POWER AND WIND POWER.

CHAPTER I.—OF SOURCES OF WATER FOR POWER.

92. Nature of Sources in general—Mill-site or Fall,	91	94. Measurement of a Source of Water Power,	92
93. Power of a Fall of Water,	91		

CHAPTER II.—OF WATER POWER ENGINES IN GENERAL.

95. Parts and Appendages of Water Power Engines,—I. Head-Race; II. By-Wash; III. Regulator; IV. Engine Proper; V. Tail-Race,	97	and Jet Pump,	98
96. Classes of Water Power Engines,—I. Water Bucket Engines; II. Water Pressure Engines; III. Vertical Water Wheels; IV. Turbines; V. Hydraulic Ram		97. Water Power Engines with Artificial sources,	98
		98. Form assumed by Energy of Fall—Dynamic Head,	98
		99. Loss of Head—Available Head and Power—Efficiency of the Fall—Factors of Resistance,	100
		100. Action of the Water on the Engine,	108

CHAPTER III.—OF WATER BUCKET ENGINES.

101. Water Bucket Hoist,	105	103. Double Acting Bucket Engine,	106
102. Loss of Head in Bucket Hoists,	106		

CHAPTER IV.—OF WATER PRESSURE ENGINES.

SECTION 1.—*General Principles.*

104. Parts of a Water Pressure Engine,	107	107 A. Pressure and Vacuum Gauges,	110
105. Suction Pipes—Vacuum,	108	108. Fixing Diameter of Supply Pipe, —(See also Article 140 A.),	112
106. Least Atmospheric Pressure,	109	109. Effect of the Regulator,	115
107. Expansion of Water by Heat—Comparison of Heads of Water with Pressures in other Units,	109	110. Action of the Water on the Piston,	116
		SECTION 2.— <i>Of Valves.</i>	
		111. Valves in general,	117

CHAPTER IV.—OF WATER PRESSURE ENGINES—continued.

Art.	Page
112. Bonnet, Pot-lid, or Conical Valve,	118
113. Common Safety Valve (Relief Clacks, see Article 134 A),	119
114. Ball Clack,	120
115. Divided Conical Valves,	120
116. Double Beat Valve—Equilibrium Valve,	120
117. Flap Valve—Butterfly clack,	122
118. Flap and Grating Valves—(see also Article 134 B),	123
119. Disc and Pivot or Throttle Valve,	123
120. Slide Valves,	124
121. Piston Valves,	125
122. Cocks,	126
123. Flexible Tube and Diaphragm Valves,	126

SECTION 3.—Of Plungers, Pistons, and Packing of Water Pressure Engines.

124. Plungers,	127
125. Cupped Leather Collar,	128
126. Leather Packed Piston,	128
127. Hempen Packing,	129

SECTION 4.—Of Hydraulic Presses and Hoists.

128. Hydraulic Press,	129
---------------------------------	-----

CHAPTER V.—OF VERTICAL WATER WHEELS.

SECTION 1.—General Principles.

137. Pond and Weir,	150
138. Backwater,	151
139. Waste sluices,	153
140. Head-Race and Sluices,	153
140 A. Table of Squares and Fifth Powers,	156
141. Regulating Sluice,	156
142. Water Wheel Governors,	158
143. General Description of Vertical Water Wheels,	160
144. Impulse of Water on Vanes,	163
145. Best form of Vane to receive Jet—Poncelet's Floats,	170
146. Effect of Friction during Impulse,	171
147. Direct Action distinguished from Reaction,	173
148. Efficiency of Vertical Water Wheels in General,—I. Weight and Impulse Wheels; II. Impulse Wheels without and with Reaction,	174
149. Choice of a Class of Wheels,	177

SECTION 2.—Of Overshot and Breast Wheels.

150. Overshot and Breast Wheels Distinguished,	177
--	-----

Art.	Page
129. Direct Water Pressure Hoists and Purchases,	133
130. Water Pressure Cage Hoist—Water Pressure Cranes,	134

SECTION 5.—Of Self-Acting Water Pressure Engines.

131. General Description,	138
132. Single Acting Water Pressure Engine,	140
133. Double Acting Water Pressure Engine,	143
134. Rotative Water Pressure Engines,	143
134 A. Relief Clacks,	144

Supplement to Part II., Chapter IV., Section 2.

134 B. Compound Clacks,	144
-----------------------------------	-----

SECTION 6.—Of Water Pressure Engines with Air Pistons.

135. Hungarian Machine,	144
136. Air Vessels,	148

Supplement to Part II., Chapter I., Article 94.

136 A. Water Meters,	148
--------------------------------	-----

151. Description of a Breast Wheel,	178
152. Diameter of Wheel,	180
153. Pinion and Cogged Rings,	181
154. Strength of Gudgeons,	181
155. Strength of Arms,	181
156. Speed and Dimensions of Shrouding,	182
157. Figure and Dimensions of Buckets,	183
158. Guide Blades and Regulator,	183
159. Breast—Tail-Race,	184
160. Efficiency—Energy of Fall per Horse-Power,	185
161. Overshot Wheels at High Speeds,	185

SECTION 3.—Of Undershot Wheels.

162. Description of a Poncelet Wheel,	186
163. Diameter of Wheel,	186
164. Depth of Shrouding,	187
165. Regulating Sluice,	187
166. Wheel Race,	187
167. Surface Velocity of Wheels,	188
168. Vanes or Floats,	188
169. Efficiency—Energy of Fall per Horse-Power,	188
170. Wheel in an Open Current,	188

CHAPTER VI.—OF TURBINES.

SECTION 1.—General Principles.		Art.	Page	Page
Art.		179.	Efficiency as affected by Regulator,	201
171.	Turbines generally Described and Classed,			189
172.	Velocity of Flow—Dimensions of Drum,			191
173.	Velocity of Whirl—Inclination of Vanes,			192
174.	Efficiency without Friction,			193
175.	Greatest Efficiency without Friction,			196
176.	Reaction Wheel,			197
177.	Efficiency of Turbines, allowing for Friction,			197
178.	Volume of Flow and size of Orifices,			200
SECTION 2.—Description of Various Turbines.				
		180.	Fontaine's Turbine,	201
		181.	Jonval's, or Koechlin & Co.'s Turbine,	203
		182.	Fourneyron's Turbine	204
		183.	Various Outward Flow Turbines,	205
		184.	Reaction Wheels,	206
		185.	Thomson's Turbine or Vortex Wheel,	207

CHAPTER VII.—OF FLUID-ON-FLUID IMPULSE ENGINES.

186.	Introductory Explanations,	211
187.	Hydraulic Ram,	211
187 A.	Jet Pump—Water Blower—Blast Pipe,	213

CHAPTER VIII.—OF WINDMILLS.

188.	General Description,	214
189.	General Principles,	215
190.	Best Form and Proportions of Sails,	217
191.	Best Speed,	218
192.	Power and Efficiency,	218
193.	Tower Mill—Self-acting Cap,	219
194.	Reefing, or Regulation of Sails,	219

PART III.—OF STEAM AND OTHER HEAT ENGINES.

195.	Nature and Division of the Subject,	223
------	---	-----

CHAPTER I.—OF RELATIONS AMONGST THE PHENOMENA OF HEAT.

196.	Heat defined and described,	224
SECTION 1.—Of Temperatures.		
197.	Equal Temperatures,	225
198.	Fixed Temperatures,	225
199.	Degrees of Temperature—Perfect Gas Thermometer,	226
200.	Different Thermometric Scales,	227
201.	Absolute Zero—Absolute Temperature,	228
202.	Expansion of Gases—Imperfect Gases—Steam,	229
203.	Expansion of Liquids—Mercurial Thermometers—Spirit Thermometers,	232
204.	Expansion of Solids—Pyrometers,	234
205.	Melting Points,	235
206.	Pressure of Vapours—Evaporation—Boiling,	235
	I. Liquid,	235
	II. Vapour,	236
	III. Pressure and Density of Vapours,	236
	IV. Atmospheres of Vapour—Spheroidal State,	238
	V. Mixtures of Vapours and Gases,	239
206.	Pressure of Vapours—continued.	
	VI. Evaporation and Condensation,	241
	VII. Ebullition,	241
	VIII. Resistance to Boiling,	242
	IX. Cloud or Nebulous Vapour,	242
	X. Superheated Vapour,	242
SECTION 2.—Of Quantities of Heat.		
207.	Comparison of Quantities of Heat—Sensible Heat,	243
207A.	Calorimeters,	244
208.	Unit of Heat,	244
209.	Specific Heat of Liquids and Solids,	245
210.	Specific Heat of Gases,	248
211.	Latent Heat,	250
212.	Latent Heat of Expansion,	250
213.	Latent Heat of Fusion—Ice,	250
214.	Latent Heat of Evaporation,	252
215.	Total Heat of Evaporation,	253
215 A.	Measurement of Heat by Evaporation,	254
216.	Total Heat of Gasefication,	255
SECTION 3.—Transfer of Heat.		
217.	Transfer of Heat in General,	257
218.	Radiation,	257

SECTION 2.— <i>Transfer of Heat—continued.</i>		Art.	Page
Art.			
219.	Conduction,	267	267
220.	Convection,	261	261
		221.	Efficiency of Heating Surface, 262
		222.	Cooling Surface—Surface-con- densation, 265

CHAPTER II.—OF COMBUSTION AND FUEL.

223.	Total Heat of Combustion of Elements,	267	227.	Total Heat of Combustion of Fuel, 277
224.	Total Heat of Combustion of Compounds,	270	228.	Radiation from Fuel, 278
225.	Ingredients of Fuel,	273	229.	Air required for Combustion and Dilution, 280
226.	Kinds of Fuel,	274	230.	Distribution of Fuel and Air, . . 281
	I. Charcoal,	274	231.	Temperature of Fire, 283
	II. Coke,	274	232.	Rate of Combustion, 284
	III. Coal,	275	233.	Draught of Furnaces, 285
	IV. Peat,	276	234.	Available Heat of Combustion— Efficiency of Furnace, 290
	V. Wood,	276		

CHAPTER III.—PRINCIPLES OF THERMODYNAMICS.

SECTION 1.— <i>Of the Two Laws of Ther- modynamics.</i>				
235.	Thermodynamics defined,	299	257.	Total Heat of Evaporation, . . . 327
236.	First Law of Thermodynamics, . . 299		258.	Total Heat of Gasefication, . . . 327
237.	Dynamical expression of Quan- tities of Heat,	300	258 A.	Latent Heat of Fusion, 331
238.	First Law represented graphically, . 301		SECTION 2.— <i>Efficiency of the Fluid in Heat Engines in General.</i>	
239.	Thermal Lines,	302	259.	Analysis of the Efficiency of Heat Engines, 332
240.	Total Actual or Sensible Heat, . . . 305		260.	Action of the Cylinder and Pis- ton—Indicated Power, 332
241.	Second Law of Thermodynamics, . . 306		261.	Double Cylinder Engines— Combination of Diagrams, . . . 334
242.	Absolute Temperature—Specific Heat, Real and Apparent, 306		262.	Fluid acting as a Cushion, 336
243.	Second Law, expressed with refer- ence to absolute Temperature, . . . 307		263.	Formulæ for Energy exerted by Fluid on Pistons, 337
244.	Second Law, Represented Graphi- cally,	308	264.	Equation between Energy and Work, 340
245.	Heat Potentials and Thermo- dynamic Functions—General Equation of Thermodynamics, . . . 309		265.	Efficiency of the Fluid in an Elementary Heat Engine, 342
			266.	Efficiency of the Fluid in Heat Engines in general, 343
SECTION 2.— <i>Expansive Action of Heat in Fluids.</i>			267.	Heat Engine of Maximum Effi- ciency, 344
246.	General Laws as applied to Fluids, . 810		268.	Heat Economizer or Regenerator, . 344
247.	Intrinsic Energy of a Fluid, 818		269.	Isodiabatic Lines, 345
248.	Expression of the Thermodyna- mic Function in Terms of the Temperature and Pressure, 814		SECTION 3.— <i>Of the Efficiency of Air Engines.</i>	
249.	Principal Applications of the Laws of the Expansive Action of Heat enumerated, 815		270.	Thermal Lines for Air, 845
250.	Real and Apparent specific Heat, . 816		271.	Thermodynamic Functions for Air, 346
251.	Heating and Cooling of Gases and Vapours by Compression and Expansion, 819		272.	Perfect Air Engine, without Re- generator, 347
252.	Velocity of Sound in Gases, 821		273.	Perfect Air Engines with Re- generators, in general, 352
253.	Free Expansion of Gases and Vapours, 322		274.	Temperature changed at Constant Pressure—Ericsson's Engine, . . . 354
254.	Flow of Gases,	324	275.	Temperature changed at Con- stant Volume—Stirling's En- gine—Napier and Rankine's Air Heater, 362
255.	Latent Heat of Evaporation, 325			
256.	Computation of the Density of Vapour from the Latent Heat, . . . 326			

CHAPTER III.—PRINCIPLES OF THERMODYNAMICS—*continued.*

Art.	Page	Art.	Page
276. Heat Received and Rejected at Constant Pressures — Joule's Engine,	871	291. Disturbing Causes— <i>continued.</i>	
277 Furnace-Gas Engines — Cayley's — Gordon's—Avenier de la Grée's,	874	I. Wire Drawing at Cut-off,	417
SECTION 5.—Of the Efficiency of Saturated Steam.		II. Clearance,	418
278. Theoretical Diagrams of Energy of Steam in general,	875	III. Compression,	420
279. Forms of Expression for Energy,	377	IV. Release,	421
279 A. Interpolation of Quantities in the Tables,	380	V. Conduction of Heat,	421
280. Back Pressure,	381	VI. Liquid Water in the Cylinder,	421
281. Thermodynamic Function and Adiabatic Curve for mixed Water and Steam,	383	VII. Undulations,	422
282. Approximate Formulae for Adiabatic Curves,	385	VIII. Friction of Indicator,	422
283. Liquefaction of Steam Working Expansively,	385	IX. Position of Indicator,	422
284. Efficiency of Steam in an Un-jacketed Cylinder,	387	292. Resistance of Engine—Efficiency of Mechanism,	422
285. Approximate Formulae for Un-jacketed Cylinders,	392	293. Action of Steam against a known Resistance — Pambour's Problem,	424
286. Use of the Steam Jacket and Hot Air Jacket,	395	294. Customary Mode of stating Pressures,	427
287. Efficiency of Dry Saturated Steam,	396	SECTION 6.—On the Action of Superheated Steam.	
288. Approximate Formulae for Dry Saturated Steam,	402	295. Objects and Methods of Superheating Steam,	428
289. Examples of the Action of Dry Saturated Steam,	404	296. Provisional Supposition as to Steam-Gas,	430
289 A. Condensing High Pressure Engines,	412	297. Efficiency of Steam-Gas expanding without gain or loss of Heat,	431
290. Difference between Pressure in Boiler and Initial Pressure in Cylinder—Wire-drawn Steam,	413	298. Efficiency of Steam-Gas expanding at constant Temperature,	437
291. Effects of Disturbing Causes on Diagrams,	417	299. Efficiency of Steam-Gas with Regenerator—Siemens' Engine,	439
CHAPTER IV.—OF FURNACES AND BOILERS.		TABLES FOR STEAM-GAS, IX, X, XI, 441	
SECTION 1.—Of Boilers and Furnaces in General.		SECTION 7.—Of Binary Vapour Engines.	
303. General Arrangements of Furnace and Boiler,	449	800. General Description of the Binary Vapour Engine,	444
304. Principal Parts and Appendages of a Furnace,	449	801. Theory of the Steam-and-Æther Engine,	445
305. Principal Parts and Appendages of a Boiler,	451	802. Example of Results of Experiments,	447
306. Grate—Fire-bars,	455	312. Strength and Construction of Boilers,	459
307. Moving Grates,	457	813. Heating Surface — Dimensions and Course of Flues,	461
308. Height of Furnace,	457	314. Total and Effective Heating Surface,	462
309. Hearth for Burning Wood,	457	815. Water Room—Steam Room,	462
310. Dead - Plate — Mouthpiece — Fire Door—Furnace Front—Ashpit Door,	458	316. Feed and Blow-off Apparatus—Donkey-Engine—Brine-Pump—Refrigerator,	464
311. Air Passages—Blowing Apparatus—Chimney,	459	317. Safety Valves,	464
		318. Steel Boilers,	465
		319. Proving Boilers,	466
		820. Explosions,	466
		821. Internal Deposit in Boilers,	467
		822. External Crust,	468
		823. Nominal Horse-Power of Boilers,	468

CHAPTER IV.—OF FURNACES AND BOILERS—*continued.*

SECTION 2.— <i>Examples of Furnaces and Boilers.</i>		Art.	Page	
Art.				
324.	Wagon Boiler,		469	
325.	Cylindrical Egg-Ended Boiler,		470	
326.	Retort Boiler,		470	
327.	Cylindrical Boilers with Heaters,		471	
328.	Cornish Boiler,		472	
		Art.	Page	
		329.	Cylindrical Double Furnace Flue Boiler,	473
		330.	Cylindrical Double Furnace Tubular Boiler,	474
		331.	Marine Flue Boilers,	474
		332.	Marine Tubular Boilers,	474
		333.	Detached-Furnace Boiler,	475
		334.	Miscellaneous Forms of Boilers,	476

CHAPTER V.—OF THE MECHANISM OF STEAM ENGINES.

SECTION 1.—*Of the Mechanism of Steam Engines in General.*

335.	Engines Classed,	478
336.	Nominal Horse-power,	479
337.	Enumeration of the Principal Parts of a Steam Engine,	480
338.	Combined Engines,	482
339.	Parts of an Engine Illustrated,	484

SECTION 2.—*Of Steam Passages, Valves, and Valve Gearing.*

340.	Steam Passages,	485
341.	Throttle Valve,	485
342.	Conical and Double-beat Valves,	485
343.	Plug Rod and Tappets—Cataract,	486
344.	Slide Valves—Long Slide—Short Slide,	486
345.	Eccentric,	490
346.	Reversing by the Loose Eccentric,	491
347.	Lead and Lap—Expansion by the Slide Valve,	491
348.	Link Motion,	496
349.	Expansion-Valve with Cams,	498
350.	Expansion Slide Valve—Grid-iron Valves,	499
351.	Double-beat Valves worked by Eccentrics,	500

SECTION 3.—*Of Cylinders, Pistons, and Piston Rods.*

352.	Common Cylinders,	500
353.	Double Cylinder Engines,	501
354.	Concentric Cylinders,	502
355.	Treble Cylinder Engines,	502
356.	End-to-End Double Cylinder Engine,	503
357.	Double Piston Engine,	503
358.	Oscillating Cylinders,	503
359.	Sector Cylinders,	503
360.	Rotatory Engines,	503
361.	Disc Engine,	504
362.	Pistons and Packing,	505
363.	Piston Rods and Trunks,	506
364.	Speed of Piston,	506

SECTION 4.—*Of Condensers and Pumps.*

365.	Watt's Condenser—Injection Valve,	507
366.	Cold Water Pump,	508
367.	Air Pump—Waste Water,	508
368.	Surface Condensers,	509

SECTION 5.—*Of Connecting Mechanism.*

369.	Beam Engines and Direct Acting Engines,	510
370.	Forces acting on Beam and Cylinder,	510
371.	Effort on Crank Pin—Fly Wheel,	511
372.	Dead Points,	512
373.	Guides for Piston Rod,	512
374.	Parallel Motions,	512
375.	Side Lever Engines,	516
376.	Varieties in Direct Acting Marine Engines,	518
377.	Couplings of Shafts in Marine Engines,	520
378.	Strength of Mechanism and Frame,	520
379.	Balancing of Mechanism,	521

SECTION 6.—*Additional Examples of Pumping and Marine Engines.*

380.	Example of Cornish Pumping Engine,	523
381.	Double Acting Pumping Engines,	525
382.	Example of Vertical Inverted Screw Marine Engines,	525

SECTION 7.—*Of Locomotive Engines.*

383.	References to previous Articles,	528
384.	Adhesion of Wheels,	528
385.	Resistance of Engines and Trains,	529
386.	Balancing of Engines,	530
387.	Blast Pipe,	531
388.	Examples of Locomotive Engines,	532
389.	Locomotive Engines for Common Roads,	537

SECTION 8.—*Of Steam Turbines.*

390.	Reaction Steam Engine,	538
391.	Fan Steam Engine,	538

ADDENDA to Articles 316 and 376,	538
--	-----

PART IV.—OF ELECTRO-MAGNETIC ENGINES.

Art.	Page	Art.	Page
392. Introductory Remarks,	539	396. Electro-chemical Circuit,	542
393. Energy, Actual and Potential,	539	397. Power and Efficiency of Electro-magnetic Engines,	544
394. Energy of Chemical Action in Galvanic Batteries,	540	398. Disc Engine,	546
395. Comparative Cost of Materials consumed in Electro-magnetic Engines and in Heat Engines,	541	399. Rotating Bar Engine,	547
		400. Plunger Engine,	548

APPENDIX.

No. I. (To Part I., Chapter IV.,) Horse-Power Engine,	550
II. (To Articles 292, 293), Efficiency of Propellers,	550
III. (To Articles 297, 298), Superheated Steam Engines,	552
IV. (To Article 337), Counter and Indicator,	552
V. (To Article 344), Equilibrium-piston for Slide Valve,	552
VI. Addenda to Table II.,	552
VII. Density of Steam,	552
VIII. Feed Apparatus,	552
TABLE I. Heights due to Velocities,	553
II. Weight, Volume, Elasticity, Expansion, and Specific Heat,	554
III. Elasticity of a Perfect Gas,	556
IV. Properties of Steam of Maximum Density by the Cubic Foot,	559
V. Properties of Vapour of Æther by the Cubic Foot,	563
VI. Properties of Steam of Maximum Density by the Pound Avoirdupois,	564
VII. Approximate Ratios for Expansion in Unjacketed Cylinders,	568
VIII. Approximate Ratios for Expansion in Jacketed Cylinders,	568
IX. Elasticity and Total Heat of Steam-gas,	441
X. Approximate Ratios for Steam-gas working expansively,	442
XI. Approximate Ratios for Perfect Gases working expansively at Constant Temperature,	443
INDEX,	569

ERRATA.

- Page 26, line 16, for "A B" read "C B."
 ,, 32, line 4 from bottom, for "36" read "26."
 ,, 96, equation 8, for " $2\cdot645 h \frac{5}{2}$ " read " $2\cdot645 a h \frac{5}{2}$."
 ,, 255, line 13, for "215 B" read "216."
 ,, 298, line 5, for "3\cdot35" read "33\cdot5."
 ,, 395, line 21, for "pruning" read "priming."
 ,, 414, line 6, for "second" read "minute."

Page 552, after line 10, insert,—There are cases in which the preceding formulæ require to be considerably modified, such as that in which a screw propeller works in the mass of water that is dragged after a bluff-sterned ship; but such cases cannot be thoroughly investigated except in connection with the principles of ship-building.

HISTORICAL SKETCH,

RELATING CHIEFLY TO

THE STEAM ENGINE.

NATIONS are wrongly accused of having, in the most ancient times, honoured and remembered their conquerors and tyrants only, and of having neglected and forgotten their benefactors, the inventors of the useful arts. On the contrary, the want of authentic records of those benefactors of mankind has arisen from the blind excess of admiration, which led the heathen nations of remote antiquity to treat their memory with divine honours, so that their real history has been lost amongst the fables of mythology.

During a period less remote, but still ancient, the improvers of the mechanical arts were neglected by biographers and historians, from a mistaken prejudice against practice, as being inferior in dignity to contemplation; and even in the case of men such as Archytas and Archimedes, who combined practical skill with scientific knowledge, the records of their labours that have reached our times give but vague and imperfect accounts of their mechanical inventions, which are treated as matters of trifling importance in comparison with their philosophical speculations. The same prejudice, prevailing with increased strength during the middle ages, and aided by the prevalence of the belief in sorcery, rendered the records of the progress of practical mechanics, until about the end of the fifteenth century, almost a blank.

These remarks apply, with peculiar force, to the history of those machines called **PRIME MOVERS**, by whose aid power or energy is derived from natural sources, and made to perform work for human purposes. It would be vain to attempt to trace the history of the application of muscular power, water power, or wind power, to the driving of machinery. With the exception of the air engine and some other heat engines, and the electro-magnetic engine, which are still in their infancy, the **STEAM ENGINE** is the only prime mover whose history is known with any certainty; and even its origin is lost in antiquity.

The published writings on the history of the steam engine are very numerous. They are to be found at the commencement of all

the large treatises on the steam engine, such as Farey's, Tredgold's, and Mr. Bourne's;—and of articles on the same subject, and on steam navigation, by Mr. Scott Russell. The most complete collection of accounts of various inventions is Stuart's *History of the Steam Engine*; a book now very scarce. A complete and exact history of the more important steps in the progress of the steam engine down to the time of Watt, and of the inventions of Watt himself, is contained in Mr. Muirhead's *Mechanical Inventions of James Watt*, and *Life of James Watt*; works specially distinguished by the fullness and precision with which original documents and authorities for facts are cited. It is impossible to pursue the same course within the limits of the present essay, which is only a brief summary of the leading events in the history of the steam engine.

The earliest written account of mechanism in which heat is made to perform work by means of steam, is contained in the *Pneumatics* of Hero of Alexandria, who flourished about 130 B.C. That author describes a rotatory engine, or steam turbine, driven by the reaction of jets of steam issuing from orifices in revolving arms, and also an engine in which the pressure of steam, or of heated air and vapour mixed, is made to raise liquid by expelling it from a receiver. An apparatus similar to the last is described by Giovanni Battista della Porta, in his *Pneumatics*, published in 1601, with this addition, that the condensation of steam within a close vessel is described as a means of producing a vacuum, and thereby causing water to ascend and fill the vessel. A French engineer, Solomon de Caus, in a work entitled *Les Raisons des Forces Mouvantes*, published in 1615, described a machine for propelling a jet of water to a great height by the pressure of steam evaporated in the same vessel from which the water was ejected. In 1629, Branca described an engine, in which a wheel was driven round by the impulse of steam against vanes. The Marquis of Worcester, in his work called *A Century of the Names and Scantlings of Inventions*, &c., published in 1663, described a machine for raising water by the pressure of steam. So far as the description is intelligible, it appears that this machine differed from that of De Caus, in having a separate boiler for the production of the steam which forced water out of other vessels; and it appears further, from the Diary of Cosmo, Grand Duke of Tuscany, that the machine of the Marquis of Worcester had been constructed, and was in operation at Vauxhall, in 1656. It is probable, that in the time of the Marquis of Worcester, the action of steam in exerting a great pressure when confined within a limited space, and the possibility of raising water to a height by means of it, had become generally known to persons acquainted with mechanics, and that the original part

of his machine was the *separate boiler*, without which it would have been practically useless. About 1697, Savery invented an engine in which water was not only (as in that of Worcester) forced above the level of the engine by the pressure of the steam from a separate boiler, but was also raised to the level of the engine, from a lower level, by the pressure of the atmosphere, after the condensation of the steam in the water receiver by means of cold water externally applied. This engine was extensively used for draining mines. In all the machines hitherto described, the steam either acted by its momentum alone, or by pressing directly on the surface of water. The first invention of the important idea of making steam afford the means of driving a *piston*, which should communicate motion to mechanism, appears to be due to Denis Papin, who, about the year 1690, constructed a working model, consisting of a vertical cylinder with a piston. In the lower part of the cylinder was placed a small quantity of water. On placing a fire under the cylinder, the water evaporated and lifted the piston; on removing the fire from the cylinder, or the cylinder from the fire, the steam was condensed, and the piston forced down by the pressure of the atmosphere. Papin proposed that engines on this principle should be made to work pumps, and also, by means of rack and pinion work, and ratchet wheels, to drive paddle wheels of vessels, and other revolving mechanism. Papin had, about ten years before, invented the safety valve for boilers. In 1705, Newcomen, Savery, and Cawley, combined the cylinder and piston with the separate boiler, and with surface condensation, and produced the well known atmospheric engine for pumping mines. They afterwards rendered the condensation more rapid and complete by injecting a shower of cold water into the interior of the cylinder. Apparatus for enabling the engine to open and shut its own valves was introduced by Humphry Potter, and improved by Beighton. The high pressure engine was invented in 1725, by Leupold. About 1770, the details of the atmospheric engine were much improved by Smeaton, until it became, considering the general condition of practical mechanics at the time, a very perfect machine in workmanship and mechanism.

Fig. I. shows a vertical section of the principal parts of Savery's engine:—*a*, receiver, in which the steam presses on the surface of the water; *b*, ascending pipe; *c d*, clacks opening upwards; *f*, boiler; *g*, steam pipe from boiler to receiver; *h*, cock, to open and close it; *i k*, flues; *l m*, gauge cocks to ascertain the water level; *n*, safety valve (it is doubtful, however, whether Savery used the safety valve); *o*, condensing cock, to let a stream of cold water fall on the receiver, and condense the steam. The engine was worked by opening and closing the cocks *h* and *o* alternately. On opening

b

h, steam from the boiler forced the water from the receiver *a* up through the pipe *b*; on closing *h* and opening *o*, the steam was

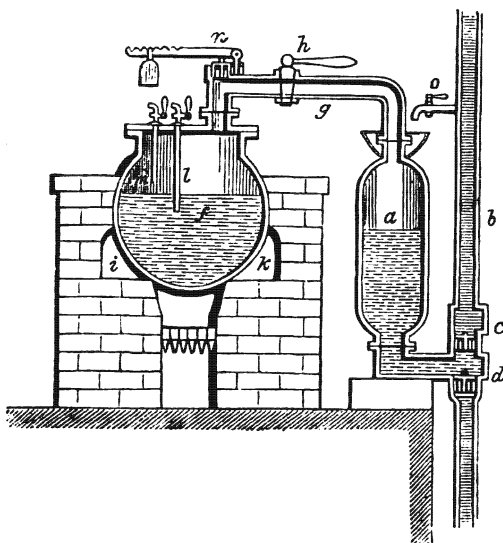

Fig. I.—Savery's Engine.

condensed, and the pressure of the atmosphere forced water up through the clack *d*, so as to fill the receiver again.

Two improvements made by Savery on his engine are not shown in the figure: a second receiver, similar to *a*, and standing alongside of it, to be filled and emptied alternately with *a*, so as to keep up a continuous stream of water; and an auxiliary boiler, or heating vessel, in which water was heated before being supplied to the principal boiler *f*, and from which the water was forced into *f* by the pressure of steam when required.

Fig. II. is Newcomen's atmospheric engine in its earliest form. *a*, beam or lever; *b*, boiler; *c*, lever wall; *d*, pump rod chain; *e*, pump rod; *f*, furnace; *g g*, counterpoise; *h*, cylinder; *p*, steam pipe; *u*, steam cock; *l*, tank for condensation water; *m*, its supply pipe, coming from the pump in the pit; *n*, condensation water pipe; *o*, cock; *q*, discharge pipe for water from cylinder, leading downwards to a point thirty-four feet below it (being one atmosphere of water); *s*, piston rod; *x*, piston rod chain; *y z*, sectors on ends of beam.

For an example of the atmospheric engine in its most perfect

state, reference may be made to the description and drawing of the "long Benton engine" in Smeaton's reports.

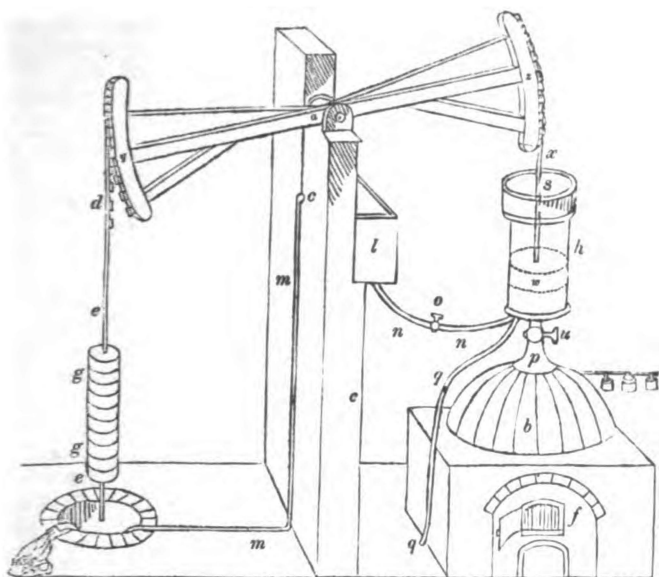

Fig. II.—Newcomen's Atmospheric Engine.

Fig. III. is Leupold's proposed high pressure engine, with a pair of cylinders in which the steam acts alternately, being admitted and discharged by a "four-way-cock."

In the history of mechanical art two modes of progress may be distinguished—the *empirical* and the *scientific*. Not the *practical* and the *theoretic*, for that distinction is fallacious: all real progress in mechanical art, whether theoretical or not, must be practical. The true distinction is this: that the empirical mode of progress is purely and simply practical; the scientific mode of progress is at once practical and theoretic.

Empirical progress is that which has been going on slowly and continually from the earliest times to the present day, by means of gradual amelioration in materials and workmanship, of small successive augmentations of the size of structures and power of machines, and of the exercise of individual ingenuity in matters of detail. This mode of progress, though essential to the perfecting of mechanical art in its details, is confined to making small altera-

tions on existing examples, and is consequently limited in the range of its effects.

Scientific progress in the mechanical arts takes place, not continuously, but at intervals, often distant, and by great efforts.

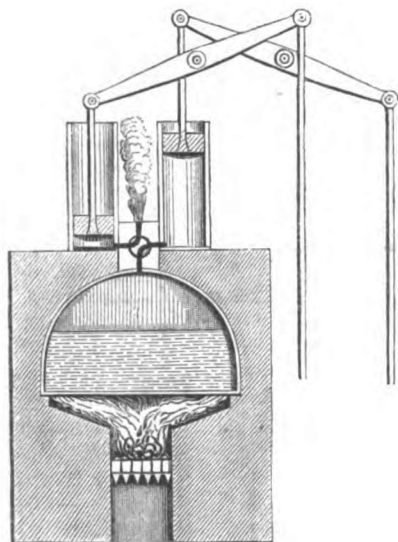

Fig. III.—Leupold's Engine.

When the results of experience and observation on the properties of the materials which are used, and on the laws of the actions which take place, in a class of machines, have been reduced to a science, then the improvement of such machines is no longer confined to amendments or enlargements in detail of previously existing examples; but from the principles of science practical rules are deduced, showing not only how to bring the machine to the condition of greatest efficiency consistent with the available materials

and workmanship, but also how to adapt it to any combination of circumstances, how different soever from those which have previously occurred. When a great advance has thus been made by scientific progress, empirical progress again comes into play, to perfect the results in their details.

Up to the period when Smeaton perfected the atmospheric engine, the progress of the "fire engine," as the steam engine was then called, had been merely *empirical*; and in everything that depended on principle, the steam engine of that period was a most rude, wasteful, and inefficient machine. Then came the time when science was to effect more in a few years than mere empirical progress had done in nineteen centuries. In 1759, James Watt had his attention directed by Robison to the subject of the steam engine, and for a few years afterwards made various experiments on the properties of steam. In 1763 and 1764, Watt, while engaged in the repair of a small model of Newcomen's engine (belonging to the University of Glasgow, and since preserved by

that University as the most precious of relics),* perceived the various defects of that machine, and ascertained by experiment their

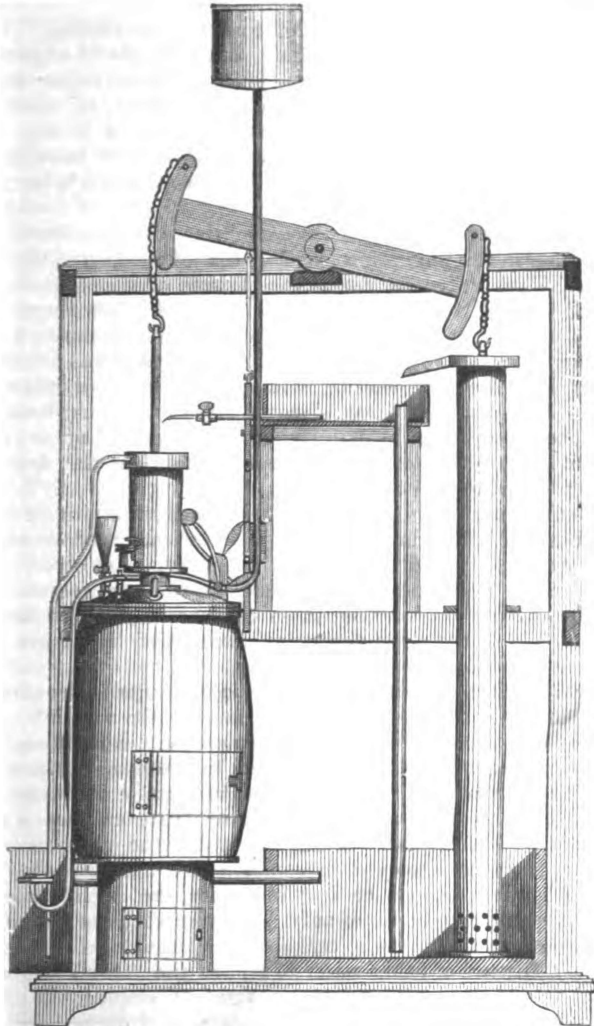

* Fig. IV.—Watt's model in Glasgow College.

causes. Watt set to work scientifically from the first. He studied the laws of the pressure of elastic fluids, and of the evaporating action of heat, so far as they were known in his time; he ascertained as accurately as he could, with the means of experimenting at his disposal, the expenditure of fuel in evaporating a given quantity of water, and the relations between the temperature, pressure, and volume of the steam. Then reasoning from the data which he had thus obtained, he framed a body of principles expressing the conditions of the efficient and economic working of the steam engine, which are embodied in an invention described by himself in the following words, in the specification of his patent of 1769:—

“My method of lessening the consumption of steam, and consequently fuel, in fire engines, consists of the following principles:—

“*First*, That vessel in which the powers of steam are to be employed to work the engine, which is called the cylinder in common fire engines, and which I call the steam vessel, must, during the whole time the engine is at work, be kept as hot as the steam that enters it; first, by inclosing it in a case of wood, or any other materials that transmit heat slowly; secondly, by surrounding it with steam or other heated bodies; and thirdly, by suffering neither water nor any other substance colder than the steam, to enter or touch it during that time.

“*Secondly*, In engines that are to be worked wholly or partially by condensation of steam, the steam is to be condensed in vessels distinct from the steam vessels or cylinders, although occasionally communicating with them; these vessels I call condensers; and, whilst the engines are working, these condensers ought at least to be kept as cold as the air in the neighbourhood of the engines, by application of water, or other cold bodies.

“*Thirdly*, Whatever air or other elastic vapour is not condensed by the cold of the condenser, and may impede the working of the engine, is to be drawn out of the steam vessels or condensers by means of pumps, wrought by the engines themselves, or otherwise.

“*Fourthly*, I intend, in many cases, to employ the expansive force of steam to press on the pistons, or whatever may be used instead of them, in the same manner in which the pressure of the atmosphere is now employed in common fire engines. In cases where cold water cannot be had in plenty, the engines may be wrought by this force of steam only, by discharging the steam into the air after it has done its office.

“*Lastly*, Instead of using water to render the pistons and other parts of the engines air and steam tight, I employ oils, wax, resinous bodies, fat of animals, quicksilver, and other metals in their fluid state.”

The expense of carrying out of Watt's invention was at first defrayed by Dr. John Roebuck, the original projector of the Carron Iron Works. On his retirement from the enterprise, his place was taken by Matthew Boulton of Birmingham, whose liberality and energy furnished all that was necessary to render the genius of Watt practically available. Few patents have had their validity more obstinately contested than that of Watt's great invention; and the successful result of the trials of which it was the subject has greatly contributed to ascertain and fix the interpretation of the patent laws. In 1769, Watt had invented the cutting-off the admission of steam, so as to make it work expansively, as appears from a letter of his to his friend Dr. Small. He began to use that invention in 1776, but did not publish it till 1782, when he patented along with it his invention of the double acting engine. It is certain that before 1778, Watt had invented the double acting steam engine, and the application of the crank to the steam engine; but the latter invention having been pirated and patented by another, Watt invented and patented other methods of producing rotatory from reciprocating motion, which were used until the patent for the crank expired; after which time the use of the crank became general. The adaptation of the steam engine to the production of rotatory motion was the crowning improvement, which led to its employment as the prime mover of every kind of mechanism. In 1784, Watt patented and published his inventions of the parallel motion, the counter for recording the strokes of engines, the throttle valve, the governor for regulating the speed, and the indicator for ascertaining the power, and also a locomotive engine; which last, however, he did not put in practice. The improvements on the steam engine since the time of Watt have chiefly related either to the boiler and furnace, to the details of the mechanism, to the more full development of Watt's principle of using the expansive force of the steam to drive the piston; or to the means of applying the steam engine to the propulsion of carriages and ships. The double cylinder engine was invented by Hornblower in 1781, and was afterwards combined with Watt's condenser by Woolf.

The history of the application of the steam engine to the propulsion of ships has been brought into a very complete state by the compilation, under the direction of Mr. Woodcroft, of abridgments of patents for marine propulsion, together with various documents relative to inventions of that class patented in Britain.

It appears from the correspondence between Papin and Leibnitz, that Papin was present, in 1688, at a trial of a boat propelled by a machine contrived by Savery, in which paddle wheels were driven by a water wheel, which was itself driven by water raised by means

of Savery's steam engine, already mentioned; and also that Papin himself, in 1707, made either a vessel or a model of a vessel (it is not clear which) on a similar plan, with which he was on his way by the Fulda and Weser to England, when it was taken from him and destroyed by boatmen.

In 1736, Jonathan Hulls patented a steam vessel in which paddle wheels were driven by ratchet work, acted upon by chains or ropes attached to the pistons of atmospheric cylinders.

In 1752, Daniel Bernouilli invented a form of screw propeller, which he proposed to drive by a steam engine.

In 1781 and 1783, the Marquis de Jouffroy executed and used upon the Rhone two steam vessels of considerable size—in the first of which paddle wheels were driven by chains, and in the second by rack work. They are said to have realized a considerable speed.

The early attempts at steam navigation made in France by the Marquis de Jouffroy in 1781 and 1783, in America by Rumsey and Fitch about 1783 and 1784, and in Scotland in 1788, and 1789, by Miller of Dalswinton, Taylor, and Symington, appear to have failed chiefly because of the imperfect nature of the means employed for the transmission of motion from the piston to the propeller. In fact, Watt's invention of [the rotative engine, which effects that transmission smoothly and without shocks, was an indispensable step towards the success of steam navigation. Symington, instructed by the previous failure of his engine in Miller's boat, availed himself of that invention, when he built for Lord Dundas, in 1801, the "Charlotte Dundas," which was used in 1802 on the Forth and Clyde Canal, with complete success as a tug, but abandoned owing to an apprehension on the part of the directors of the canal to the banks. The "Charlotte Dundas" (fig. V.) had one

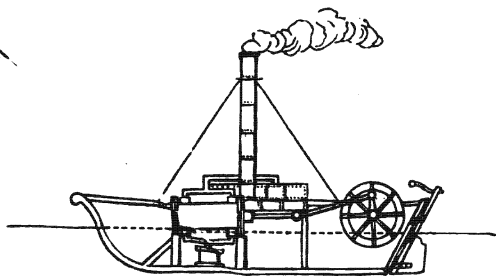

Fig. V.—The "Charlotte Dundas," 1801-2.

paddle wheel near the stern, driven by a direct acting horizontal

engine, with a connecting rod and crank. The arrangement of her mechanism was such as would be considered creditable at the present day; and she has been justly styled by Mr. Woodcroft "the first practical steamboat."

Fulton having made himself well acquainted with what had been previously done in steam navigation, began to experiment with a small paddle steamer in 1803. In 1804, Stevens ran a steamer between New York and Hoboken, with a screw propeller, driven by one of Watt's engines.

The establishment of steam navigation as a remunerative art was first effected in America, by Fulton, in 1807, on the East river; and in Europe, by Bell, in 1812, on the Clyde. Fulton's vessel, the "Clermont," was propelled by paddles, driven by an engine made by Boulton and Watt. Bell's vessel, the "Comet," was propelled by two pairs of paddles (fig. VI), driven by an

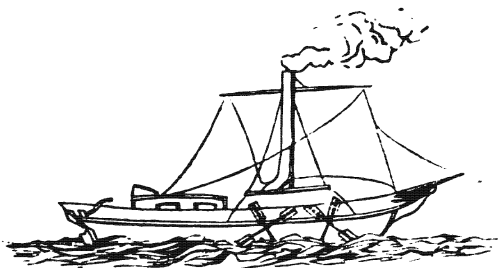

Fig. VI.—The "Comet," 1811-12.

engine of peculiar design (fig. VII.) Since that period the advancement of steam navigation has consisted not so much in the development of new principles, as in the improvement of workmanship, arrangement, and economy of fuel, and the progress of increase of the size, power, and speed of steam ships, and the of their voyages—the climax at the present time being the "Eastern," 680 feet long, 83 feet broad, drawing 30 feet, when loaded, displacing 26,000 tons of water, having a boiler capable of working at from 8,000 to 12,000 indicated horse power, and capable of carrying coals for a voyage round the world of the quality, as Mr. Scott Russell has stated, is the best of any to be had in bulk. The highest speed attained in Europe is 17½ nautical miles, or 20 statute miles per hour, and in some instances, by steamers on the Atlantic, 20 or 22 miles per hour. If a similar vessel were to be built, it would be a great improvement on the present state of the art.

The application of the steam engine to land locomotion, according to Watt, suggested by James Watt, was first applied to the

patented a locomotive engine, which, however, he never executed. About the same time Murdoch, assistant to Watt, made a very

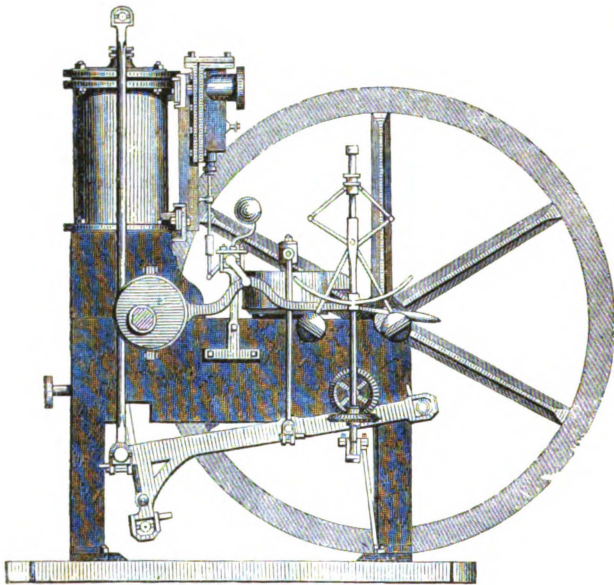

Fig. VII.—Engine of the “Comet,” 1811-12.

efficient working model of a locomotive engine. In 1802, Trevithick and Vivian patented a locomotive engine, which was constructed and set to work in 1804 or 1805. It travelled at about five miles per hour, with a net load of ten tons. The use of fixed steam engines to drag trains on railways by ropes, was introduced by Cook

various inventors had long exerted their ingenuity in the locomotive engine a firm hold of the track by work-rails, and toothed driving wheels, legs, and contrivances, Blackett and Hedley, in 1813, made the discovery that no such aids are required, the tooth wheels and smooth rails being sufficient. The engine to the great and widely varied uses to travel, and the varied loads which

Fig. V.—The original source of the power of the paddle wheel near the stern, draws the work which the engine has to

perform, and shall, when required, be capable of being increased to many times the rate at which fuel is burned in the furnace of a stationary engine of the same size; and that the surface through which heat is communicated from the burning fuel to the water shall be very large compared with the bulk of the boiler. The first of these objects is attained by the *blast-pipe*, invented and used by George Stephenson before 1825; the second, by the tubular boiler, invented about 1829, simultaneously by Séguin in France and Booth in England, and by the latter suggested to Stephenson. On the 6th October, 1829, occurred that famous trial of locomotive engines, when the prize offered by the directors of the Liverpool and Manchester Railway was gained by Stephenson's engine, the "Rocket," the parent of the swift and powerful locomotives of the present day, in which the blast-pipe and tubular boiler are combined. (Fig. VIII.) Since that time the locomotive engine has been varied and

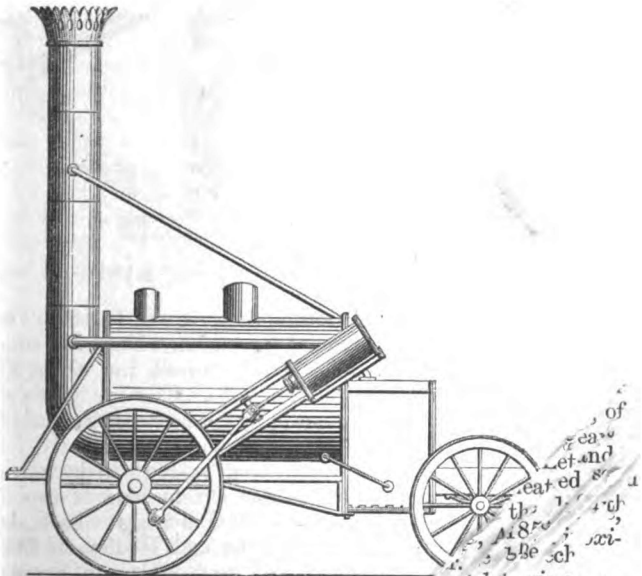

Fig. VIII.—The "Rocket," 1825

improved in various details, and by varying the pressure, now ranges from five tons to fifty tons, and its speed from ten to hundred tons; its speed from ten to hundred tons; its speed from ten to hundred tons. The reduction of the laws wh...

energy to a physical theory, or connected system of principles, called the science of Thermodynamics, is of recent date, and, in many respects, may be considered to be still in progress. The steps in reasoning, and in experimental knowledge, which have gradually led to the formation of that system of principles, are difficult to trace, and more difficult to separate from the history of the two kinds of mechanical hypotheses which have been proposed as means of deducing the laws of heat from those of motion and force; for one of those hypotheses—that which supposes the phenomena of heat to be caused by the presence, in greater or less quantity, of a substance called "*caloric*"—has been the chief impediment to the progress of the accurate knowledge of the laws of the relations between heat and motive power; while the other hypothesis, which supposes the phenomena of heat to be caused by molecular vibrations and revolutions, has been the means, in some instances, of anticipating laws, and predicting numerical results, which have since been confirmed by experiment, and in others, of suggesting experiments whereby important laws have been discovered.

In the stage which our knowledge has now attained, it is possible to express the laws of thermodynamics in the form of independent principles, deduced by induction from the facts of observation and experiment, without reference to any hypothesis as to the occult molecular operations with which the sensible phenomena may be conceived to be connected; and that course will be followed in the body of the present treatise. But, in giving a brief historical sketch of the progress of thermodynamics, the progress of the hypothesis of thermic molecular motions cannot be wholly separated from that of the purely inductive theory.

The Aristotelian hot element, as well as the other *στοιχία*, appears, so far as we can judge, to have been understood by Aristotle himself, not as a *substance*, but as one of the *states* of which substances are susceptible.

In the *scholastic* sense of the term "*Elementum Ignis*," viz, the hot substance, afterwards called "*phlogiston*" and "*caloric*," Lavoisier disputes the real existence of anything corresponding to it, and declares it to be one of those "*nomina nihilorum*" which he calls "*Idola fori molestissima*." The hypothesis of molecular motions was maintained by Galileo, Bacon, Boyle, Daniel Bernoulli, and later by Rumford, Davy, Leslie, Montgolfier, and Grove. Rumford and Davy supported their views by experiments on the production of heat by friction, which is the key to the whole science of thermodynamics. Lavoisier endeavoured to put the mechanical theory on a firm basis: Young, in his lectures, stating that the heat produced in a forcible manner peculiar to him,

Fig. V.—1.

showed that the facts of experiment, as known in his time, were conclusive against the hypothesis of substantial caloric. That hypothesis, however, continued to hold its ground, and to a considerable extent does so still—a fact which is probably in a great measure owing to the employment of its language in works of reference, and to the popular tendency to ascribe substantive existence to the subject of a name. The adoption of the hypothesis of thermic molecular motions, and, what is of more importance, the abandonment of the hypothesis of substantial caloric, have been much promoted by the series of discoveries which have shown, that the communication of light and heat by radiation, if not actually consisting in the propagation of molecular vibratory movements, takes place according to laws analogous to those of the propagation of such movements, and wholly at variance with those of the diffusion of any conceivable substance.

A most important step towards the formation of a true physical theory of the relations, not only between heat and motive power, but between heat and every other kind of physical energy, was made by Black's great discovery of latent heat, and by Watt's application of that discovery in the improvement of the steam engine.

The term "*latent heat*," when freed from hypothetical notions, means, an amount of that condition of matter called *heat*, which has disappeared in producing physical effects different from heat,—such as expansion, fusion, evaporation, and chemical changes,—and which may be made to reappear by reversing the changes in which such physical effects consisted,—that is, by compression, congelation, liquefaction of vapours, and inverse chemical changes. The progress in the true theory of thermodynamics, to which this discovery might have led, was for a long time retarded by a fallacious principle, arising from the hypothesis of substantial caloric in the following manner:—Let a substance change from a less bulky to a more bulky condition, or from the liquid to the gaseous state, or generally, from the state A to the state B, that change being of such a nature, that according to Black's discovery, heat disappears and some physical effect different from heat is produced. Let this operation be called (A, B), and let H_1 be the amount of heat which disappears. Next, let the substance change back from the state B to the original state A: let this change be called (B, A), because a certain quantity of heat H_0 to reappear. If the process of intermediate changes undergone by the substance during the process (B, A), be exactly the reverse, step by step, to which undergone during the process (A, B), every physical effect of the first process will be exactly undone by the second, and a resultant physical effect will ensue from the second, if a similar condition and the amount of heat which reappears, be the same where re-



equal to the amount of heat H_1 , which formerly disappeared. This was understood from the time of the first discovery of latent heat; and so far there is no fallacy, but an important truth. But it was further assumed, that heat has a substantial existence, and that, consequently, $H_0 = H_1$, under all circumstances, even although the processes (A, B) and (B, A) should differ in their intermediate steps. This assumption leads to the following paradoxical result, which shows it to be fallacious. It is known that the process (B, A) may be made to differ from (A, B), in its intermediate steps, in such a manner that a permanent mechanical effect shall be produced by the combined processes. Now, if under such circumstances H_0 is assumed to be still $= H_1$, it follows, that by employing the mechanical effect of the combined processes in *developing heat by friction*, we may *increase the amount of heat in the universe, or create caloric*;—a consequence opposed to the original assumption of the substantiality of caloric, and proving that assumption to be self-contradictory.

That fallacious assumption unfortunately pervaded the reasonings of Carnot (son of the great Carnot), in his *Réflexions sur la Puissance Motrice du Feu* (Paris, 1824)—a work which, notwithstanding this fallacy, contains the first discovery of an important law:—*that the ratio of the greatest possible work performed by a heat engine, to the whole heat expended, is a function of the two limits of temperature between which the engine works, and not of the nature of the substance employed.*—(Thomson's *Account of Carnot's Theory*, Edinb. Trans., 1849, Vol. xvi.)—The fallacy referred to prevented Carnot from discovering what that function of the limits of temperature is.

The phenomena of the development of heat by the friction of a fluid possesses peculiar advantages as a means of ascertaining the relations between heat and mechanical power, owing to the simplicity of the action which takes place; for at the end of the process the fluid is left exactly in the same condition as it was at the beginning; so that the evolution of a certain amount of heat is the effect produced; and this being compared with the mechanical work expended in agitating the fluid, exhibits in the most simple, accurate, and satisfactory manner possible, the relation between heat and mechanical power. The idea of subjecting this to experimental measurement appears to have been practiced independently by M. Mayer in 1842, and Mr. Joule in 1843. The numerical results at first obtained were, as shown in a new kind of experiment, somewhat rough and uncertain. By long perseverance, Mr. Joule increased the accuracy of his experiments, until he succeeded in determining the mechanical equivalents on the friction of water, oil, mercury, and iron, by means of a paddle wheel near the steel axis, to the accuracy of $\frac{1}{100}$ of its amount, if

not more closely still, the *mechanical equivalent of a unit of heat*; that is, the number of foot-pounds of mechanical energy which must be expended in order to raise the temperature of one pound of water by one degree. For Fahrenheit's degree, that quantity is 772 foot-pounds: for the Centigrade degree, $\frac{9}{5} \times 772 = 1389.6$ foot-pounds (*Phil. Trans.*, 1850). This, the most important numerical constant in molecular physics, has been styled by other writers on the subject "Joule's Equivalent," in order that the name of its discoverer may be perpetuated by connection with the most imperishable of memorials—a truth. Mr. Joule, at the same time, proved by experiment the law which had previously been only a matter of speculative theory with others: that not only heat and motive power, but all other kinds of physical energy, such as chemical action, electricity, and magnetism, are convertible and equivalent; that is to say, that any one of those kinds of energy may, by its expenditure, be made the means of developing any other in certain definite proportions. Meanwhile, partly through a theoretical anticipation of this law, and partly through the influence of the hypothesis of *molecular motions* as applied to heat, the formation of a systematic theory of the relations between heat and motive power advanced. Messrs. Helmholtz and Waterston may be referred to as having aided that progress. The investigations of the Count de Pambour on the theory of the steam engine, although not involving the discovery of any principle in thermodynamics properly speaking, were conducive to the progress of that science by pointing out the proper mode of applying mechanical principles to the expansive action of an elastic fluid.

The *general equation of thermodynamics*, which expresses the relations between heat and mechanical energy under all circumstances, was arrived at independently, and by different methods, in 1849, by Professor Clausius and the Author of this work; and published by the former in *Poggendorff's Annalen*, and communicated by the latter to the Royal Society of Edinburgh in February, 1850. (*Edin. Trans.*, 1850). The consequences of that equation have since been developed, and applied to scientific and practical questions in a series of papers which have appeared in *Poggendorff's Annalen*; the *Philosophical Magazine* since 1850; the *Edinburgh Philosophical Journal* for 1849 and 1850; the *Transactions of the Royal Society of Edinburgh*, since 1850; and the *Philosophical Transactions* for 1854 and 1855.

Professor William Thomson, adopting the true ratio to which 1850, not only solved some new problems in the change devised and carried out, jointly with Mr. Joule, a series of important experiments; but he extended analogously a similar relation on tricity and magnetism, and thereby created a new branch of science re-

styled a new science. His papers have appeared in the *Transactions of the Royal Society of Edinburgh* for 1851, and subsequently in the *Philosophical Magazine* since 1851, and the *Philosophical Transactions* since 1854. Numerical data, without which the theoretical researches before referred to would have been fruitless, were furnished by the experiments of Dulong, and MM. Bravais, Martins, Moll, Van Beek, and others, on the velocity of sound; by those of M. Rudberg, on the expansion of gases; by the experiments, almost unparalleled for extent and precision, of M. Regnault, on the properties of gases and vapours, made at the expense of the French Government, and published in the *Proceedings and Memoirs of the Academy of Sciences*, from 1847 to 1854; and by the joint experiments of Messrs. Joule and Thomson, on the thermic effects of currents of elastic fluids, made at the expense of the Royal Society, and published in the *Philosophical Transactions* for 1854.

HYPOTHESIS OF MOLECULAR VORTICES.—In thermodynamics as well as in other branches of molecular physics, the laws of phenomena have to a certain extent been anticipated, and their investigation facilitated, by the aid of hypotheses as to occult molecular structures and motions with which such phenomena are assumed to be connected. The hypothesis which has answered that purpose in the case of thermodynamics, is called that of “molecular vortices,” or otherwise, the “centrifugal theory of elasticity.” (On this subject, see the *Edinburgh Philosophical Journal*, 1849; *Edinburgh Transactions*, vol. xx.; and *Philosophical Magazine*, *passim*, especially for December, 1851, and November and December, 1855.)

SCIENCE OF ENERGETICS.—Although the mechanical hypothesis just mentioned may be useful and interesting as a means of anticipating laws, and connecting the science of thermodynamics with that of ordinary mechanics, still it is to be remembered that the science of thermodynamics is by no means dependent for its certainty on that or any other hypothesis, having been now reduced to a system of principles, or general facts, expressing strictly the results of experiment as to the relations between heat and motive power. In this point of view the laws of thermodynamics may be regarded as particular cases of more general laws, applicable to all states of matter as constitute *Energy*, or the capacity to perform work, which more general laws form the basis of the *science of Energetics*.—a science comprehending, as special branches, the science of motion, heat, light, electricity, and all other physical

November, 1859.—The experiments of Mr. Fairbairn and Mr. Fig. 10 have just been published. They agree well with the work (see page 552).

paddle wheel near the *Edinburgh Philosophical Journal*, 1855.

INTRODUCTION.

OF MACHINES IN GENERAL.

SECTION 1.—*Of Resistance and Work.*

1. The **Action of a Machine** is to produce Motion against Resistance. For example, if the machine is one for lifting solid bodies, such as a crane, or fluid bodies, such as a pump, its action is to produce upward motion of the lifted body against the resistance arising from gravity; that is, against its own weight: if the machine is one for propulsion, such as a locomotive engine, its action is to produce horizontal or inclined motion of a load against the resistance arising from friction, or from friction and gravity combined: if it is one for shaping materials, such as a planing machine, its action is to produce relative motion of the tool and of the piece of material shaped by it, against the resistance which that material offers to having part of its surface removed; and so of other machines.

2. **Work.** (*A. M.*, 513.)—The action of a machine is measured, or expressed as a definite quantity, by multiplying the motion which it produces into the resistance, or force directly opposed to that motion, which it overcomes; the product resulting from that multiplication being called **WORK**.

In Britain, the distances moved through by pieces of mechanism are usually expressed in feet; the resistances overcome, in pounds *avoirdupois*; and quantities of work, found by multiplying distances in feet by resistances in pounds, are said to consist of so many *foot-pounds*. Thus the work done in lifting a weight of one pound, through a height of one foot, is *one foot-pound*; the work done in lifting a weight of twenty pounds, through a height of one hundred feet, is $20 \times 100 = 2,000$ foot-pounds.

In France, distances are expressed in *mètres*, resistances in *kilogrammes*, and quantities of work in what are called *grammètres*, one *kilogrammètre* being the work performed in lifting a weight of one *kilogramme* through a height of one *mètre*. If a similar machine were represented by a weight of one *kilogramme* through a height of one *mètre*, the work done would be one *grammètre*. The following are the proportions amongst resistances, and work, with their logarithms.

	Logarithms.
One mètre = 3.2808992 feet,.....	0.5159929
One foot = 0.30479449 mètres,.....	1.4840071
One kilogramme = 2.20462 lbs. avoirdupois,.....	0.3433340
One lb. avoirdupois = 0.453593 kilogramme,.....	1.6566660
One kilogrammètre = 7.23314 foot-pounds,.....	0.8593269
One foot-pound = 0.138253 kilogrammètres,.....	1.1406731

3. The **Rate of Work** of a machine means, the quantity of work which it performs in some given interval of time, such as a second, a minute, or an hour (*A. M.*, 661). It may be expressed in units of work (such as foot-pounds) per second, per minute, or per hour, as the case may be; but there is a peculiar unit of power appropriated to its expression, called a **HORSE-POWER**, which is, in Britain,

550 foot-pounds per second,
or 33,000 foot-pounds per minute,
or 1,980,000 foot-pounds per hour.

This is also called an *actual* or *real* horse-power, to distinguish it from a *nominal* horse-power, the meaning of which will afterwards be explained. It is greater than the performance of any ordinary horse, its name having a conventional value attached to it.

In France, the term **FORCE DE CHEVAL**, or **CHEVAL-VAPEUR**, is applied to the following rate of work :—

	Foot-lbs.
75 kilogrammètres per second =	542½
or 4,500 kilogrammètres per minute =	32,549
or 270,000 kilogrammètres per hour =	1,952,948

being about one-seventieth part less than the British horse-power.

4. **Velocity**.—If the *velocity of the motion* which a machine causes to be performed against a given resistance be given, then the product of that velocity into the resistance obviously gives the rate of work, or effective power. If the velocity is given in feet per second, and the resistance in pounds, then their product is the rate of work in foot-pounds per second, and so of minutes, or hours, or other time.

—The most convenient, for purposes of calculation, to express the velocities of the parts of machines either in feet per second, or in feet per minute. For certain dynamical calculations referred to, the second is the more convenient unit. In the performance of machines for practical purposes, the foot-pound is the unit most commonly employed.

Comparison of Different Measures of Velocity.

	Miles per hour.	Feet per second.	Feet per minute.	Feet per hour.
	1	= 1'46	= 88	= 5280
	0'6818	= 1	= 60	= 3600
	0'01136	= 0'016	= 1	= 60
	0'0001893	= 0'00027	= 0'016	= 1
1 nautical mile } per hour, or "knot,"	= 1'1507	= 1'6877	= 101'262	= 6075'74

The units of time being the same in all civilized countries, the proportions amongst their units of velocity are the same with those amongst their linear measures.

5. *Work in Terms of Angular Motion.* (A. M., 593.)—When a resisting force opposes the motion of a part of a machine which moves round a fixed axis, such as a wheel, an axle, or a crank, the product of the amount of that resistance into its *leverage* (that is, the perpendicular distance of the line along which it acts from the fixed axis) is called the *moment*, or *statical moment*, of the resistance. If the resistance is expressed in pounds, and its leverage in feet, then its moment is expressed in terms of a measure which may be called a *foot-pound*, but which, nevertheless, is a quantity of an entirely different kind from a foot-pound of work.

Suppose now that the body to whose motion the resistance is opposed turns through any number of revolutions, or parts of a revolution; and let T denote the angle through which it turns, expressed in revolutions, and parts of a revolution; also, let

$$2 \pi = 6.2832$$

denote, as is customary, the ratio of the circumference of a circle to its radius. Then the distance through which the given resistance is overcome is expressed by

$$\text{the leverage} \times 2 \pi \times T;$$

that is, by the product of the circumference of a circle whose radius is the leverage, into the number of turns and fractions made by the rotating body.

The distance thus found being multiplied by the resistance which comes, gives the work performed; that is to say, $\text{work} = \text{resistance} \times \text{distance}$

The work performed = *the resistance* \times *the leverage* \times 2π \times *T*

But the product of the resistance into the leverage is what is called the *moment* of the resistance, and the product $2\pi T$ is called the *angular motion* of the rotating body; consequently,

$$\begin{aligned} & \textit{The work performed} \\ & = \textit{the moment of the resistance} \times \textit{the angular motion.} \end{aligned}$$

The mode of computing the work indicated by this last equation is often more convenient than the direct mode already explained in Article 2.

The angular motion $2\pi T$ of a body during some definite unit of time, as a second or a minute, is called its *angular velocity*; that is to say, *angular velocity is the product of the turns and fractions of a turn made in an unit of time into the ratio ($2\pi = 6.2832$) of the circumference of a circle to its radius.* Hence it appears that

$$\begin{aligned} & \textit{The rate of work} \\ & = \textit{the moment of the resistance} \times \textit{the angular velocity.} \end{aligned}$$

6. **Work in Terms of Pressure and Volume.** (*A. M.*, 517.)—If the resistance overcome be a pressure uniformly distributed over an area, as when a piston drives a fluid before it, then the amount of that resistance is equal to the intensity of the pressure, expressed in units of force on each unit of area (for example, in pounds on the square inch, or pounds on the square foot) multiplied by the area of the surface at which the pressure acts, if that area is perpendicular to the direction of the motion; or, if not, then by the projection of that area on a plane perpendicular to the direction of motion. In practice, when the *area of a piston* is spoken of, it is always understood to mean the projection above mentioned.

Now, when a plane area is multiplied into the distance through which it moves in a direction perpendicular to itself, if its motion is straight, or into the distance through which its centre of gravity moves, if its motion is curved, the product is the *volume of the space traversed* by the piston.

Hence the work performed by a piston in driving a fluid before it, or by a fluid in driving a piston before it, may be expressed in any one of the following ways:—

$$\begin{aligned} & \textit{Resistance} \times \textit{distance traversed} \\ & \textit{—intensity of pressure} \times \textit{area} \times \textit{distance traversed}; \\ & \textit{—intensity of pressure} \times \textit{volume traversed.} \end{aligned}$$

Fig. compute the work in foot-pounds, if the pressure is in pounds per square foot, the area should be stated in square feet, and the distance in feet; if the pressure is stated in pounds per square inch, the area should be stated in square inches, and the distance in inches; if the pressure is stated in pounds per cubic foot, the volume should be stated in cubic feet; if the pressure is stated in pounds per cubic inch, the volume should be stated in cubic inches.

pounds on the square inch, the area should be stated in square inches, and the volume in units, each of which is a prism of one foot in length and one square inch in area; that is, of $\frac{1}{144}$ of a cubic foot in volume.

The following table gives a comparison of various units in which the intensities of pressures are commonly expressed. (A. M., 86.)

	Pounds on the square foot.	Pounds on the square inch.
One pound on the square inch,.....	144	1
One pound on the square foot,.....	1	$\frac{1}{144}$
One inch of mercury (that is, weight of a column of mercury at 32° Fahr., one inch high),.....	70.73	0.4912
One foot of water (at 39.1 Fahr.),	62.425	0.4335
One inch of water,.....	5.2021	0.036125
One atmosphere, of 29.922 inches of mercury, or 760 millimètres,	2116.4	14.7
One foot of air, at 32° Fahr., and under the pressure of one atmosphere,.....	0.080728	0.0005606
One kilogramme on the square mètre,	0.20481	0.00142228
One kilogramme on the square millimètre,	204810	1422.28
One millimètre of mercury,.....	2.7847	0.01934

7. Algebraical Expressions for Work. (A. M., 515, 517, 593.)—

To express the results of the preceding articles in algebraical symbols, let

s denote the distance in feet through which a resistance is overcome in a given time;

R , the amount of the resistance overcome in pounds.

Also, supposing the resistance to be overcome by a piece which turns about an axis, let

T be the number of turns and fractions of a turn made in given time, and $i = 2\pi T = 6.2832 T$ the angular motion; o original time; and let

l be the leverage of the resistance; that is, the perpendicular distance of the line along which it acts from the axis to which so that $s = il$, and Rl is the statical moment of the resistance; when posing the resistance to be a pressure, exerted by a fluid, represented a fluid, let A be the area or projected area of the surface on intensity of the pressure in pounds per unit area where the resistance re-

Then the following expressions all give quantities of work in the given time in foot-pounds:—

$$R s; i R l; p A s; i p A l.$$

The last of these expressions is applicable to a piston turning on an axis, for which l denotes the distance from the axis to the centre of gravity of the area A .

8. **Work Against an Oblique Force.** (*A. M.*, 511.)—The resistance directly due to a force which acts against a moving body in a direction oblique to that in which the body moves, is found by resolving that force into two components, one at right angles to the direction of motion, which may be called a *lateral force*, and which must be balanced by an equal and opposite lateral force, unless it takes effect by altering the direction of the body's motion, and the other component directly opposed to the body's motion, which is the *resistance* required. That resolution is effected by means of the well known principle of the parallelogram of forces as follows:—

In fig. 1, let A represent the point at which a resistance is overcome, AB the direction in which



Fig. 1.

that point is moving, and let \overline{AF} be a line whose direction and length represent the direction and magnitude of a force obliquely opposed to the motion of A .

From F upon BA produced, let fall the perpendicular \overline{FR} ; the length of that perpendicular will represent the magnitude of the lateral component of the oblique force, and the length \overline{AR} will represent the direct component or resistance.

To express this in algebraical symbols, let F denote the obliquely applied force, θ the angle of its obliquity, or $\angle RAF$, Q the lateral force, and R the resistance; then

$$Q = F \cdot \sin \theta; R = F \cdot \cos \theta.$$

9. **Summation of Quantities of Work.**—In every machine, resistances are overcome during the same interval of time, by different moving pieces, and at different points in the same moving and the whole work performed during the given interval is adding together the several products of the resistances respective distances through which they are simultaneously

It is convenient, in algebraical symbols, to denote the summation by the symbol—

$$\Sigma \cdot R s; \dots\dots\dots(1.)$$

paddle wheel near the the operation of taking the sum of a set of

quantities of the kind denoted by the symbols to which it is prefixed.

When the resistances are overcome by pieces turning upon axes, the above sum may be expressed in the form—

$$\Sigma \cdot i R l ; \dots\dots\dots(2.)$$

and so of other modes of expressing quantities of work.

The following are particular cases of the summation of quantities of work performed at different points:—

I. In a *shifting piece*, or one which has the kind of movement called *translation only*, the velocities of every point at a given instant are equal and parallel; hence, in a given interval of time, the motions of all the points are equal; and the work performed is to be found by multiplying the *sum of the resistances* into the motion as a common factor; an operation expressed algebraically thus—

$$s \Sigma R ; \dots\dots\dots(3.)$$

II. For a *turning piece*, the angular motions of all the points during a given interval of time are equal; and the work performed is to be found by multiplying the *sum of the moments of the resistances relatively to the axis* into the angular motion as a common factor—an operation expressed algebraically thus—

$$i \Sigma \cdot R l ; \dots\dots\dots(4.)$$

The sum denoted by $\Sigma \cdot R l$ is the *total moment of resistance* of the piece in question.

III. In every *train of mechanism*, the *proportions* amongst the motions performed during a given interval of time by the several moving pieces, can be determined from the mode of connection of those pieces, independently of the absolute magnitudes of those motions, by the aid of the science called by Mr. Willis, *Pure Mechanism*. This enables a calculation to be performed which is called *reducing the resistances to the driving point*; that is to say, determining the resistances, which, if they acted directly at the point where the motive power is applied to the machine, would require the same quantity of work to overcome them with their actual resistances.

Suppose, for example, that by the principles of pure mechanics it is found, that a certain point in a machine, where a resistance is to be overcome, moves with a velocity bearing the ratio which the velocity of the driving point. Then the work performed in overcoming that resistance will be the same as if a resistance were overcome directly at the driving point. If a similar condition be made for each point in the machine where a resistance re-

overcome, and the results added together, as the following symbol denotes:—

$$\Sigma \cdot n R, \dots\dots\dots(5.)$$

that sum is the *equivalent resistance at the driving point*; and if in a given interval of time the driving point moves through the distance *s*, then the work performed in that time is—

$$s \Sigma \cdot n R. \dots\dots\dots(6.)$$

The process above described is often applied to the steam engine, by reducing all the resistances overcome to equivalent resistances acting directly against the motion of the piston.

A similar method may be applied to the moments of resistances overcome by rotating pieces, so as to reduce them to *equivalent moments at the driving axle*. Thus, let a resistance *R*, with the leverage *l*, be overcome by a piece whose angular velocity of rotation bears the ratio *n* : 1 to that of the driving axle. Then the equivalent moment of resistance at the driving axle is *n R l*; and if a similar calculation be made for each rotating piece in the machine which overcomes resistance, and the results added together, the sum—

$$\Sigma \cdot n R l \dots\dots\dots(7.)$$

is the total *equivalent moment of resistance at the driving axle*; and if in a given interval of time the driving axle turns through the arc *i* to radius unity, the work performed in that time is—

$$i \Sigma \cdot n R l \dots\dots\dots(8.)$$

IV. *Centre of Gravity*.—The work performed in lifting a body is the *product of the weight of the body into the height through which its centre of gravity is lifted*.

If a machine lifts the centres of gravity of several bodies at once to heights either the same or different, the whole quantity of work performed in so doing is the sum of the several products of the weights and heights; but that quantity can also be computed by *multiplying the sum of all the weights into the height through which their common centre of gravity is lifted*.

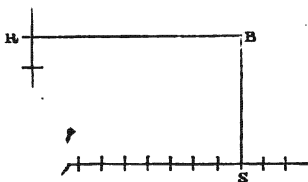

Fig. 2.

10. *Representation of Work by an Area*.—As a quantity of work is the product of two quantities, a force and a motion, it may be represented by the

paddle wheel plane figure, which is the product of two dimensions.

Let the base of the rectangle A , fig. 2, represent *one foot* of motion, and its height *one pound* of resistance; then will its area represent one foot-pound of work.

In the larger rectangle, let the base \overline{OS} represent a certain motion s , on the same scale with the base of the unit-area A ; and let the height \overline{OR} represent a certain resistance R , on the same scale with the height of the unit-area A ; then will the number of times that the rectangle $\overline{OS} \cdot \overline{OR}$ contains the unit-rectangle A , express the number of foot-pounds in the quantity of work $R s$, which is performed in overcoming the resistance R through the distance s .

11. **Work Against Varying Resistance.** (*A. M.*, 515).—In fig. 3,

let distances as before, be represented by lengths measured along the base line OX of the figure; and let the magnitudes of the resistance overcome at each instant be represented by the lengths of ordinates drawn perpendicular to OX , and parallel to OY :—For example,

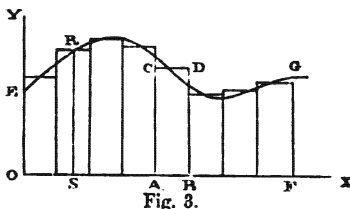

Fig. 3.

when the working body has moved through the distance represented by \overline{OS} , let the resistance be represented by the ordinate \overline{SR} .

If the resistance were constant, the summits of those ordinates would lie in a straight line parallel to OX , like RB in fig. 2; but if the resistance varies continuously as the motion goes on, the summits of the ordinates will lie in a line, straight or curved, such as that marked $ER G$, fig. 3, which is not parallel to OX .

The values of the resistance at each instant being represented by the ordinates of a given line $ER G$, let it now be required to determine the work performed against that resistance during a motion represented by $OF = s$.

Suppose the area $OEGF$ to be divided into bands by a series of parallel ordinates, such as AC and BD , and between the upper ends of those ordinates let a series of short lines, such as CD , be drawn parallel to OX , so as to form a stepped or serrated outline, consisting of lines parallel to OX and OY alternately, and approximating to the given continuous line EG .

Now conceive the resistance, instead of varying continuously, to remain constant during each of the series of divisions into which the motion is divided by the parallel ordinates, and to change abruptly at the instants between those divisions, being represented for each division by the height of the rectangle which stands on that division: for example, during the division of the motion re-

presented by $\overline{A B}$, let the resistance be represented by $A C$, and so for other divisions.

Then the work performed during the division of the motion represented by $\overline{A B}$, on the supposition of alternate constancy and abrupt variation of the resistance, is represented by the rectangle $\overline{A B} \cdot \overline{A C}$; and the whole work performed, on the same supposition, during the whole motion $\overline{O F}$, is represented by the sum of all the rectangles lying between the parallel ordinates; and inasmuch as the supposed mode of variation of the resistance represented by the stepped outline of those rectangles is an approximation to the real mode of variation represented by the continuous line $E G$, and is a closer approximation the closer and the more numerous the parallel ordinates are, so the sum of the rectangles is an approximation to the exact representation of the work performed against the continuously varying resistance, and is a closer approximation the closer and more numerous the ordinates are, and by making the ordinates numerous and close enough, can be made to differ from the exact representation by an amount less than any given difference.

But the sum of those rectangles is also an approximation to the area $O E G F$, bounded above by the continuous line $E G$, and is a closer approximation the closer and the more numerous the ordinates are, and by making the ordinates numerous and close enough, can be made to differ from the area $O E G F$ by an amount less than any given difference.

Therefore the area $O E G F$, bounded by the straight line $O F$, which represents the motion, by the line $E G$, whose ordinates represent the values of the resistance, and by the two ordinates $O E$ and $F G$, represents exactly the work performed.

The MEAN RESISTANCE during the motion is found by dividing the area $O E G F$ by the motion $\overline{O F}$.

The following is the mode of expressing the above results in algebraical symbols:—

Let any division of the motion, such as $\overline{A B}$, be denoted by Δs ; $s = \Sigma \cdot \Delta s$ being the sum of all these divisions, or the entire motion $\overline{O F}$.

Let one of the values of the resistance for the division $\overline{A B}$ of the motion be R ; and let this represent the height $\overline{A C}$ of the rectangle which stands on $A B$ in the approximate representation of the work. Then

$$R \Delta s$$

represents the area of that rectangle; and the sum of the whole series of rectangles, which is an approximate representation of the work performed, is denoted by

$$\sum R \Delta s \dots \dots \dots (1.)$$

The limit or INTEGRAL towards which that sum approximates as the divisions Δs are increased indefinitely in number, and diminished indefinitely in length, being the area O E G F, and the exact representation of the work performed, is denoted by

$$\int R ds; \dots \dots \dots (2.)$$

and the mean resistance by

$$\frac{\int R ds}{s} \dots \dots \dots (3.)$$

To illustrate the application of those principles by an example, let there be a spiral spring which exerts a tension of 100 lbs. when it is stretched one-tenth of a foot, and whose tension at other elongations varies simply as the elongation; and let it be required to find how much work is performed in stretching it from its ordinary state to an elongation of 0.06 of a foot. In fig. 4, on the straight line O X, take \overline{OA} to represent 0.1

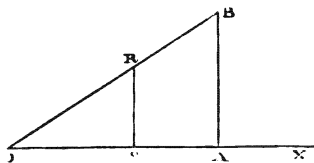

Fig. 4.

foot, and draw $\overline{AB} \perp \overline{OX}$ to represent 100 lbs. Draw the straight line O B; then because the tensions are simply proportional to the elongations, the ordinate $\overline{RS} \parallel \overline{AB}$ will represent the tension R for any given elongation $\overline{OS} = s$; and the triangular area O S R = $\frac{R s}{2}$ will represent the work performed in producing that elongation. In the present case,

$$s = 0.06 \text{ foot; } R = \frac{0.06 \times 100}{0.1} = 60 \text{ lbs.; and}$$

$$\frac{R s}{2} = 1.8 \text{ foot-pounds,}$$

while the mean resistance during the elongation is

$$\frac{R s}{2} \div s = \frac{R}{2} = 30 \text{ lbs.}$$

11 A. **Approximate Computation of Integrals.** (Extracted from A. M., 81).—Reference having been made to the process of *integration*, the present article is intended to afford to those who have not

made that branch of mathematics a special study, some elementary information respecting it.

The meaning of the symbol of an integral, viz. :—

$$\int y \, dx,$$

is of the following kind :—

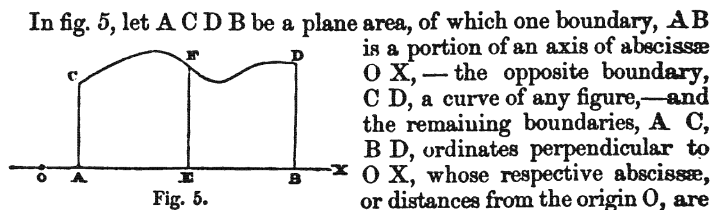

Fig. 5.

$$\overline{O A} = a; \quad \overline{O B} = b.$$

Let $\overline{E F} = y$ be any ordinate whatsoever of the curve C D, and $\overline{O E} = x$ the corresponding abscissa. Then the integral denoted by the symbol,

$$\int_a^b y \, dx,$$

means, *the area of the figure A C D B*. The abscissæ a and b , which are the least and greatest values of x , and which indicate the longitudinal extent of the area, are called the *limits of integration*; but when the longitudinal extent of the area is otherwise indicated, the symbols of those limits are sometimes omitted, as in the preceding Article.

When the relation between y and x is expressed by any ordinary algebraical equation, the value of the integral for a given pair of values of its limits can generally be found by means of formulæ which are contained in works on the Integral Calculus, or by means of mathematical tables.

Cases may arise, however, in which y cannot be so expressed in terms of x ; and then approximate methods must be employed. Those approximate methods are founded upon the division of the area to be measured into bands by parallel and equi-distant ordinates, the approximate computation of the areas of those bands, and the adding of them together; and the more minute that division is, the more near is the result to the truth. The simplest approximation is as follows :—

Divide the area A C D B, as in fig. 6, into any convenient num-

ber of bands by parallel ordinates, whose uniform distance apart is Δx ; so that if n be the number of bands, $n + 1$ will be the number of ordinates, and

$$b - a = n \Delta x,$$

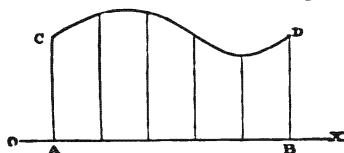

Fig. 6.

the length of the figure.

Let y' , y'' , denote the two ordinates which bound one of the bands; then the area of that band is

$$\frac{y' + y''}{2} \cdot \Delta x, \text{ nearly};$$

and consequently, adding together the approximate areas of all the bands,—denoting the extreme ordinates as follows,—

$$\overline{AC} = y_n; \quad \overline{BD} = y_0;$$

and the intermediate ordinates by y_i , we find for the approximate value of the integral—

$$\int_a^b y \, dx = \left(\frac{y_n}{2} + \frac{y_0}{2} + \sum y_i \right) \Delta x, \text{ nearly.}$$

12. Useful Work and Lost Work.—The useful work of a machine is that which is performed in effecting the purpose for which the machine is designed. The lost work is that which is performed in producing effects foreign to that purpose. The resistances overcome in performing those two kinds of work are called respectively *useful resistance* and *prejudicial resistance*.

The useful work and the lost work of a machine together make up its *total* or *gross work*.

In a pumping engine, for example, the useful work in a given time is the product of the weight of water lifted in that time into the height to which it is lifted: the lost work is that performed in overcoming the friction of the water in the pumps and pipes, the friction of the plungers, pistons, valves, and mechanism, and the resistance of the air pump and other parts of the engine.

In many machines, there is great difficulty in precisely drawing the line between useful work and lost work. In the case of the special subjects of this treatise, **PRIME MOVERS**, that difficulty seldom exists. They are *machines for driving other machines*; so that their useful work is that performed in overcoming the resistances of the machines which they drive; and their lost work is that performed in overcoming their own resistances.

For example, the useful work of a marine steam engine in a given time is the product of the resistance opposed by the water to the motion of the ship, into the distance through which she moves: the lost work is that performed in overcoming the resistance of the water to the motion of the propeller through it, the friction of the mechanism, and the other resistances of the engine, and in raising the temperature of the condensation water, of the gases which escape by the chimney, and of adjoining bodies.

There are some cases, such as those of muscular power and of windmills, in which the useful work of a prime mover can be determined, but not the lost work.

13. **Friction.** (Partly extracted and abridged from *A. M.*, 189, 190, 191, 204, and 669 to 685).—The most frequent cause of loss of work in machines is friction—being that force which acts between two bodies at their surface of contact so as to resist their sliding on each other, and which depends on the force with which the bodies are pressed together. The following law respecting the friction of solid bodies has been ascertained by experiment:—

The friction which a given pair of solid bodies, with their surfaces in a given condition, are capable of exerting, is simply proportional to the force with which they are pressed together.

There is a limit to the exactness of the above law, when the pressure becomes so intense as to crush or grind the parts of the bodies at and near their surface of contact. At and beyond that limit the friction increases more rapidly than the pressure; but that limit ought never to be attained at the bearings of any machine. For some substances, especially those whose surfaces are sensibly indented by a moderate pressure, such as timber, the friction between a pair of surfaces which have remained for some time at rest relatively to each other, is somewhat greater than that between the same pair of surfaces when sliding on each other. That excess, however, of the *friction of rest* over the *friction of motion*, is instantly destroyed by a slight vibration; so that the *friction of motion* is alone to be taken into account as causing continuous loss of work. In general, the bearings of machines ought not to be left long enough at rest at a time to allow the friction sensibly to increase beyond the friction of motion.

The friction between a pair of bearing surfaces is calculated by multiplying the force with which they are directly pressed together, by a factor called the *co-efficient of friction*, which has a special value depending on the nature of the materials and the state of the surfaces as to smoothness and lubrication. Thus, let R denote the friction between a pair of surfaces; Q , the force, in a direction perpendicular to the surfaces, with which they are pressed together; and f the co-efficient of friction; then

$$R = f Q \dots\dots\dots(1.)$$

The co-efficient of friction of a given pair of surfaces is the tangent of an angle called the *angle of repose*, being the greatest angle which an oblique pressure between the surfaces can make with a perpendicular to them, without making them slide on each other.

The following is a table of the angle of repose ϕ , the co-efficient of friction $f = \tan \phi$, and its reciprocal $1 : f$, for the materials of mechanism—condensed from the tables of General Morin, and other sources, and arranged in a few comprehensive classes. The values of those constants which are given in the table have reference to the *friction of motion*.*

No.	SURFACES.	ϕ	f	$1 : f$
1	Wood on wood, dry,.....	14° to $26\frac{1}{2}^\circ$.25 to .5	4 to 2
2	" " soaped,.....	$11\frac{1}{2}^\circ$ to 2°	.2 to .04	5 to 25
3	Metals on oak, dry,	$26\frac{1}{2}^\circ$ to 31°	.5 to .6	2 to 1.67
4	" " wet,	$13\frac{1}{2}^\circ$ to $14\frac{1}{2}^\circ$.24 to .26	4.17 to 3.85
5	" " soapy,.....	$11\frac{1}{2}^\circ$.2	5
6	Metals on elm, dry,.....	$11\frac{1}{2}^\circ$ to 14°	.2 to .25	5 to 4
7	Hemp on oak, dry,.....	28°	.53	1.89
8	" " wet,.....	$18\frac{1}{2}^\circ$.33	3
9	Leather on oak,.....	15° to $19\frac{1}{2}^\circ$.27 to .38	3.7 to 2.86
10	Leather on metals, dry,.....	$29\frac{1}{2}^\circ$.56	1.79
11	" " wet,.....	20°	.36	2.78
12	" " greasy,.....	13°	.23	4.35
13	" " oily,.....	$8\frac{1}{2}^\circ$.15	6.67
14	Metals on metals, dry,.....	$8\frac{1}{2}^\circ$ to $11\frac{1}{2}^\circ$.15 to .2	6.67 to 5
15	" " wet,.....	$16\frac{1}{2}^\circ$.3	3.33
16	Smooth surfaces, occasionally greased,	4° to $4\frac{1}{2}^\circ$.07 to .08	14.3 to 12.5
17	" " continually greased,	3°	.05	20
18	" " best results,.....	$1\frac{3}{4}^\circ$ to 2°	.03 to .036	33.3 to 27.6
19	Bronze on lignum vitæ, constantly wet,	$3^\circ ?$.05 ?	20 ?

* In a paper, of which an abstract has appeared in the *Comptes Rendus* of the French Academy of Sciences for the 26th of April, 1858, M. H. Bochet describes a series of experiments which have led him to the conclusion, that the friction between a pair of surfaces of iron is not, as it has hitherto been believed, absolutely independent of the velocity of sliding, but that it diminishes slowly as that velocity increases, according to a law expressed by the following formula. Let

R denote the friction ;

Q, the pressure ;

v, the velocity of sliding, in mètres per second = velocity in feet per second $\times 0.3048$;

f, a, γ , constant co-efficients ; then

$$\frac{R}{Q} = \frac{f + \gamma av}{1 + av}$$

The following are the values of the co-efficients deduced by M. Bochet from his

14. **Unguents.**—Three results in the preceding table, Nos. 16, 17, and 18, have reference to smooth firm surfaces of any kind, greased or lubricated to such an extent that the friction depends chiefly on the continual supply of unguent, and not sensibly on the nature of the solid surfaces; and this ought almost always to be the case in machinery. Unguents should be thick for heavy pressures, that they may resist being forced out, and thin for light pressures, that their viscosity may not add to the resistance.

Unguents may be divided into four classes, as follows:—

I. *Water*, which acts as an unguent on surfaces of wood and leather. It is not, however, an unguent for a *pair* of metallic surfaces; for when applied to them, it increases their friction.

II. *Oily unguents*, consisting of animal and vegetable fixed oils, as tallow, lard, lard oil, seal oil, whale oil, olive oil. The vegetable drying oils, such as linseed oil, are unfit for unguents, as they absorb oxygen, and become hard. The animal oils are on the whole better than the vegetable oils.

III. *Soapy unguents*, composed of oil, alkali, and water. For a temporary purpose, such as lubricating the ways for the launch of a ship, one of the best unguents of this class is soft soap, made from whale oil and potash, and used either alone or mixed with tallow. But for a permanent purpose, such as lubricating railway carriage axles, it is necessary that the unguent should contain less water and more oil or fatty matter than soft soap does, otherwise it would dry and become stiff by the evaporation of the water. The best grease for such purposes does not contain more than from 25 to 30 per cent. of water; that which contains 40 or 50 per cent. is bad.

IV. *Bituminous unguents*, composed of solid and liquid mineral hydrocarbons. These unguents have the advantage of not becoming dry, nor being altered by the action of the air.

The *intensity of the pressure* between a pair of greased surfaces ought not to be so great as to force out the unguent. It appears, that in practice, the following are ordinary values of that intensity:—

	Lbs. per square inch.
1. For cylindrical journals,.....	45 ^o to 150
mult. For flat pivots,.....	224 ^o
by a For timber ways used in launching ships,.....	50
value d. For iron surfaces of wheels and skids rubbing longitudinally on iron surfaces	
friction b. For perpendicular surfaces, 0.3, 0.25, 0.2; for damp surfaces, 0.14.	
pendicular c. For wheels sliding on rails, 0.08; for skids sliding on rails, 0.07.	
and f the c. determined, but treated meanwhile as inappreciably small.	

The *work performed* in a given time in overcoming the friction between a pair of surfaces is the product of that friction into the distance through which one surface slides over the other.

When the motion of one surface relatively to the other consists in rotation about an axis, the work performed may also be calculated by multiplying the relative *angular motion* of the surfaces to radius unity into the *moment of friction*; that is, the product of the friction into its leverage, which is the mean distance of the rubbing surfaces from the axis.

For a cylindrical journal, the leverage of the friction is simply the radius of the journal.

For a *flat pivot*, the leverage is two-thirds of the radius of the pivot.

For a *collar*, let r and r' be the inner and outer radii; then the leverage of the friction is

$$\frac{2}{3} \cdot \frac{r^3 - r'^3}{r^2 - r'^2} \dots \dots \dots (1.)$$

For "*Schiele's anti-friction pivot*," whose longitudinal section is the curve called the "*tractrix*," the moment of friction is $f \times$ the load \times the external radius. This is greater than the moment for an equally smooth flat pivot of the same radius; but the anti-friction pivot has the advantage, inasmuch as the wear of the surfaces is uniform at every point, so that they always fit each other accurately, and the pressure is always uniformly distributed, and never becomes, as is the case in other pivots, so intense at certain points as to force out the unguent and grind the surfaces.

In the *cup and ball* pivot, the end of the shaft, and the step on which it presses, present two recesses facing each other, into which are fitted two shallow cups of steel or hard bronze. Between the concave spherical surfaces of those cups is placed a steel ball, being either a complete sphere, or a lens having convex surfaces of a somewhat less radius than the concave surfaces of the cups. The moment of friction of this pivot is at first almost inappreciable, from the extreme smallness of the radius of the circles of contact of the ball and cups; but as they wear, that radius and the moment of friction increase.

By the rolling of two surfaces over each other without sliding, a resistance is caused, which is called sometimes "*rolling friction*," but more correctly *rolling resistance*. It is of the nature of a *couple* resisting rotation; its *moment* is found by multiplying the normal pressure between the rolling surfaces by an *arm* whose length depends on the nature of the rolling surfaces; and the work lost in an unit of time in overcoming it is the product of its moment by the *angular velocity* of the rolling surfaces relatively to each

other. The following are approximate values of the arm in *decimals of a foot* :—

Oak upon oak,.....	0.006 (Coulomb).
Lignum-vitæ on oak,.....	0.004 —
Cast-iron on cast-iron,.....	0.002 (Tredgold).

The work lost in friction produces HEAT in the proportion of one British thermal unit, being so much heat as raises the temperature of a pound of water one degree of Fahrenheit, for every 772 foot-pounds of lost work.

The heat produced by friction, when moderate in amount, is useful in softening and liquefying unguents; but when excessive, it is prejudicial by decomposing the unguents, and sometimes even by softening the metal of the bearings, and raising their temperature so high, as to set fire to neighbouring combustible matters.

Excessive heating is prevented by a constant and copious supply of a good unguent. The elevation of temperature produced by the friction of a journal is sometimes used as an experimental test of the quality of unguents. When the velocity of rubbing is about four or five feet per second, the elevation of temperature has been found by some recent experiments to be, with good fatty and soapy unguents, 40° to 50° Fahrenheit, with good mineral unguents about 30°.

14A. Work of Acceleration. (*A. M.*, 12, 521–33, 536, 547, 549, 554, 589, 591, 593, 595–7.)—In order that the velocity of a body's motion may be changed, it must be acted upon by some other body with a force in the direction of the change of velocity, which force is proportional directly to the change of velocity, and to the mass of the body acted upon, and inversely to the time occupied in producing the change. If the change is an acceleration or increase of velocity, let the first body be called the *driven body*, and the second the *driving body*. Then the force must act upon the driven body in the direction of its motion. Every force being a pair of equal and opposite actions between a pair of bodies, the same force which accelerates the driven body is a *resistance* as respects the driving body.

For example, during the commencement of the stroke of the piston of a steam engine, the velocity of the piston and of its rod is accelerated; and that acceleration is produced by a certain part of the pressure between the steam and the piston, being the excess of the pressure above the whole resistance which the piston has to overcome. The piston and its rod constitute the driven body; the surfaces of the driving body; and the same part of the pressure which acts on the piston, acts as a *resistance* to the motion of the piston. In addition to the resistance which would have to be overcome if the velocity of the piston were uniform.

The resistance due to acceleration is computed in the following manner:—It is known by experiment, that if a body near the earth's surface is accelerated by the attraction of the earth,—that is, by its own weight, or by a force equal to its own weight, its velocity goes on continually increasing very nearly at the rate of *32.2 feet per second of additional velocity, for each second during which the force acts.* This quantity varies in different latitudes, and at different elevations, but the value just given is near enough to the truth for purposes of mechanical engineering. For brevity's sake, it is usually denoted by the symbol g ; so that if at a given instant the velocity of a body is v_1 feet per second, and if its own weight, or an equal force, acts freely on it in the direction of its motion for t seconds, its velocity at the end of that time will have increased to

$$v_2 = v_1 + g t \dots\dots\dots(1.)$$

If the acceleration be at any different rate per second, *the force necessary to produce that acceleration, being the resistance on the driving body due to the acceleration of the driven body, bears the same proportion to the driven body's weight which the actual rate of acceleration bears to the rate of acceleration produced by gravity acting freely.*

To express this by symbols, let the weight of the driven body be denoted by W . Let its velocity at a given instant be v_1 feet per second; and let that velocity increase at an uniform rate, so that at an instant t seconds later, it is v_2 feet per second.

Let f denote the rate of acceleration; then

$$f = \frac{v_2 - v_1}{t}; \dots\dots\dots(2.)$$

and the force R necessary to produce it will be given by the proportion,

$$g : f :: W : R;$$

that is to say,

$$R = \frac{f W}{g} = \frac{W (v_2 - v_1)}{g t} \dots\dots\dots(3.)$$

The factor $\frac{W}{g}$, in the above expression, is called the **MASS** of the driven body; and being the same for the same body, in what place soever it may be, is held to represent the *quantity of matter* in the body.

The product $\frac{W v}{g}$ of the mass of a body into its velocity at any

instant, is called its **MOMENTUM**; so that the resistance due to a given acceleration is equal to *the increase of momentum divided by the time which that increase occupies.*

If the product of the force by which a body is accelerated, equal and opposite to the resistance due to acceleration, into the time during which it acts, be called **IMPULSE**, the same principle may be otherwise stated by saying, that *the increase of momentum is equal to the impulse by which it is caused.*

If the rate of acceleration is not constant, but variable, the force R varies along with it. In this case, the value, at a given instant of the rate of acceleration, is represented by $f = \frac{dv}{dt}$, and the corresponding value of the force is

$$R = \frac{fW}{g} = \frac{W}{g} \cdot \frac{dv}{dt} \dots \dots \dots (4.)$$

The **WORK PERFORMED** in accelerating a body is the product of the resistance due to the rate of acceleration into the distance moved through by the driven body while the acceleration is going on. The resistance is equal to the mass of the body, multiplied by the increase of velocity, and divided by the time which that increase occupies. The distance moved through is the product of the mean velocity into the same time. Therefore, the work performed is equal to the mass of the body multiplied by the increase of the velocity, and by the mean velocity; that is, *to the mass of the body, multiplied by the increase of the half-square of its velocity.*

To express this by symbols, in the case of an uniform rate of acceleration, let s denote the distance moved through by the driven body during the acceleration; then

$$s = \frac{v_2 + v_1}{2} t; \dots \dots \dots (5.)$$

which being multiplied by equation 3, gives for the work of acceleration,

$$R s = \frac{W}{g} \cdot \frac{v_2 - v_1}{t} \cdot \frac{v_2 + v_1}{2} \cdot t = \frac{W}{g} \cdot \frac{v_2^2 - v_1^2}{2} \dots \dots \dots (6.)$$

In the case of a variable rate of acceleration, let v denote the mean velocity, and ds the distance moved through, in an interval of time dt so short that the increase of velocity dv is indefinitely small compared with the mean velocity. Then

$$ds = v dt; \dots \dots \dots (7.)$$

which being multiplied by equation 4, gives for the work of acceleration during the interval $d t$,

$$\begin{aligned} R d s &= \frac{W}{g} \cdot \frac{d v}{d t} \cdot v d t \\ &= \frac{W}{g} \cdot v d v; \dots\dots\dots(8.) \end{aligned}$$

and the *integration* of this expression (see Article 11 A) gives for the work of acceleration during a finite interval,

$$\int R d s = \frac{W}{g} \int v d v = \frac{W}{g} \cdot \frac{v_2^2 - v_1^2}{2} \dots\dots\dots(9.)$$

being the same with the result already arrived at in equation 6.

From equation 9 it appears that *the work performed in producing a given acceleration depends on the initial and final velocities, v_1 and v_2 , and not on the intermediate changes of velocity.*

If a body falls freely under the action of gravity from a state of rest through a height h , so that its initial velocity is 0, and its final velocity v , the work of acceleration performed by the earth on the body is simply the product $W h$ of the weight of the body into the height of fall. Comparing this with equation 6, we find—

$$h = \frac{v^2}{2g} \dots\dots\dots(10.)$$

This quantity is called the *height, or fall, due to the velocity v* ; and from equations 6 and 9 it appears that *the work performed in producing a given acceleration is the same with that performed in lifting the driven body through the difference of the heights due to its initial and final velocities.*

If work of acceleration is performed by a prime mover upon bodies which neither form part of the prime mover itself, nor of the machines which it is intended to drive, that work is lost; as when a marine engine performs work of acceleration on the water that is struck by the propeller.

Work of acceleration performed on the moving pieces of the prime mover itself, or of the machinery driven by it, is not necessarily lost, as will afterwards appear.

15. Summation of Work of Acceleration—Moment of Inertia—Reduced Inertia.—If several pieces of a machine have their velocities increased at the same time, the work performed in accelerating them is the sum of the several quantities of work due to the acceleration of the respective pieces; a result expressed in symbols by

$$\Sigma \left\{ \frac{W}{g} \cdot \frac{v_2^2 - v_1^2}{2} \right\} \dots\dots\dots(1.)$$

The process of finding that sum is facilitated and abridged in certain cases by special methods.

I. *Accelerated Rotation—Moment of Inertia.*—Let a denote the angular velocity of a solid body rotating about a fixed axis;—that is, as explained in Article 5, the velocity of a point in the body whose radius-vector, or distance from the axis, is unity.

Then the velocity of a particle whose distance from the axis is r , is

$$v = a r; \dots\dots\dots(2.)$$

and if in a given interval of time the angular velocity is accelerated from the value a_1 to the value a_2 , the increase of the velocity of the particle in question is

$$v_2 - v_1 = r (a_2 - a_1) \dots\dots\dots(3.)$$

Let w denote the weight, and $\frac{w}{g}$ the mass of the particle in question. Then the work performed in accelerating it, being equal to the product of its mass into the increase of the half-square of its velocity, is also equal to *the product of its mass into the square of its radius-vector, and into the increase of the half-square of the angular velocity*; that is to say, in symbols,

$$\frac{w}{g} \cdot \frac{v_2^2 - v_1^2}{2} = \frac{w r^2}{g} \cdot \frac{a_2^2 - a_1^2}{2} \dots\dots\dots(4.)$$

To find the work of acceleration for the whole body, it is to be conceived to be divided into small particles, whose velocities at any given instant, and also their accelerations, are proportional to their distances from the axis; then the work of acceleration is to be found for each particle, and the results added together. But in the sum so obtained, the increase of the half-square of the angular velocity is a common factor, having the same value for each particle of the body; and the rate of acceleration produced by gravity, $g = 32.2$, is a common divisor. It is therefore sufficient to *add together the products of the weight of each particle (w) into the square of its radius-vector (r^2), and to multiply the sum so obtained ($\Sigma w r^2$) by the increase of the half-square of the angular velocity ($\frac{1}{2} (a_2^2 - a_1^2)$), and divide by the rate of acceleration due to gravity (g). The result, viz. :—*

$$\Sigma \left\{ \frac{w}{g} \cdot \frac{v_2^2 - v_1^2}{2} \right\} = \frac{a_2^2 - a_1^2}{2g} \cdot \Sigma w r^2 \dots\dots\dots(5.)$$

is the work of acceleration sought. In fact, the sum $\Sigma w r^2$ is *the weight of a body, which, if concentrated at the distance unity from*

the axis of rotation, would require the same work to produce a given increase of angular velocity which the actual body requires.

The term **MOMENT OF INERTIA** is applied in some writings to the sum $\sum w r^2$, and in others to the corresponding mass $\sum w r^2 \div g$. For purposes of mechanical engineering, the sum $\sum w r^2$ is, on the whole, the most convenient, bearing as it does the same relation to angular acceleration which *weight* does to acceleration of linear velocity.

The *Radius of Gyration*, or *Mean Radius* of a rotating body, is a line whose square is the mean of the squares of the distances of its particles from the axis; and its value is given by the following equation:—

$$\rho^2 = \frac{\sum w r^2}{\sum w} \dots\dots\dots(6.)$$

so that if we put $W = \sum w$ for the weight of the whole body, the moment of inertia may be represented by

$$I = W \rho^2 \dots\dots\dots(7.)$$

The following examples of radii of gyration of bodies of different figures rotating about their axes of figure are extracted from a more extensive table in *A. M.*, 578:—

FIGURE OF SOLID.	SQUARE OF RADIUS OF GYRATION.
Sphere of radius r ,	$\frac{2 r^2}{5}$
Spherical shell—external radius r , internal r' ,	$\frac{2 (r^5 - r'^5)}{5 (r^3 - r'^3)}$
Spherical shell, insensibly thin, radius r ,	$\frac{2 r^2}{3}$
Cylinder or flat circular disc, radius r ,	$\frac{r^2}{2}$
Hollow cylinder or ring, external radius r , internal r' ,	$\frac{r^2 + r'^2}{2}$
Hollow cylinder or ring, insensibly thin, radius r ,	r^2

The square of the radius of gyration of a body rotating about an axis which does not traverse its centre of gravity, is equal to the square of its radius of gyration about a parallel axis traversing its centre of gravity, added to the square of the distance between those two axes.

II. *Inertia Reduced to the Driving Point.*—If by the principles of

pure mechanism it is known, that in a machine, a certain moving piece whose weight is W , has a velocity always bearing the ratio $n:1$ to the velocity of the driving point, it is evident that when the driving point undergoes a given acceleration, the work performed in producing the corresponding acceleration in the piece in question is the same with that which would have been required if a weight $n^2 W$ had been concentrated at the driving point.

If a similar calculation be performed for each moving piece in the machine, and the results added together, the sum

$$\Sigma \cdot n^2 W \dots\dots\dots(8.)$$

gives the weight which, being concentrated at the driving point, would require the same work for a given acceleration of the driving point that the actual machine requires; so that if v_1 is the initial, and v_2 the final velocity of the driving point, the work of acceleration of the whole machine is

$$\frac{v_2^2 - v_1^2}{2g} \cdot \Sigma \cdot n^2 W \dots\dots\dots(9.)$$

This operation may be called *the reduction of the inertia to the driving point*. Mr. Moseley, by whom it was first introduced into the theory of machines, calls the expression (8.) the "*co-efficient of steadiness*," for reasons which will afterwards appear.

In finding the reduced inertia of a machine, the mass of each rotating piece is to be treated as if concentrated at a distance from its axis equal to its radius of gyration ρ ; so that if v represents the velocity of the driving point at any instant, and a the corresponding angular velocity of the rotating piece in question, we are to make

$$n^2 = \frac{a^2 \rho^2}{v^2} \dots\dots\dots(10.)$$

in performing the calculation expressed by the formula (8.)

16. **Summary of Various Kinds of Work.**—In order to present at one view the symbolical expression of the various modes of performing work described in the preceding articles, let it be supposed that in a certain interval of time dt the driving point of a machine moves through the distance ds ; that during the same time its centre of gravity is elevated through the height dh ; that resistances, any one of which is represented by R , are overcome at points, the respective ratios of whose velocities to that of the driving point are denoted by n ; that the weight of any piece of the mechanism is W , and that n' denotes the ratio of its velocity (or if it rotates, the ratio of the velocity of the end of its radius of gyration) to the velocity of the driving point; and that the driving point, whose mean velocity

is $v = \frac{ds}{dt}$, undergoes the acceleration dv . Then the *whole work performed* during the interval in question is

$$dh \cdot \Sigma W + ds \cdot \Sigma n R + \frac{v dv}{g} \cdot \Sigma n^2 W \dots (1.)$$

The *mean total resistance, reduced to the driving point*, may be computed by dividing the above expression by the motion of the driving point $ds = v dt$, giving the following result:—

$$\frac{dh}{ds} \cdot \Sigma W + \Sigma n R + \frac{dv}{g dt} \cdot \Sigma n^2 W \dots \dots \dots (2.)$$

SECTION 2.—Of Deviating and Centrifugal Force.

17. Deviating Force of a Single Body. (*A. M.*, 537.)—It is part of the first law of motion, that if a body moves under no force, or balanced forces, it moves in a straight line. (*A. M.*, 510, 512.)

It is one consequence of the second law of motion, that in order that a body may move in a curved path, it must be continually acted upon by an unbalanced force at right angles to the direction of its motion, the direction of the force being that towards which the path of the body is curved, and its magnitude bearing the same ratio to the weight of the body that the height due to the body's velocity bears to half the radius of curvature of its path.

This principle is expressed symbolically as follows:—

Half radius of curvature.	Height due to velocity.	Body's weight.	Deviating force.
$\frac{r}{2}$	$\frac{v^2}{2g}$	W	$Q = \frac{W v^2}{g r} \dots \dots \dots (1.)$

In the case of projectiles and of the heavenly bodies, deviating force is supplied by that component of the mutual attraction of two masses which acts perpendicular to the direction of their relative motion. In machines, deviating force is supplied by the strength or rigidity of some body, which *guides* the revolving mass, making it move in a curve.

A pair of free bodies attracting each other have both deviated motions, the attraction of each guiding the other; and their deviations of motion relatively to their common centre of gravity are inversely as their masses.

In a machine, each revolving body tends to press or draw the body which guides it away from its position, in a direction from the centre of curvature of the path of the revolving body; and that tendency is resisted by the strength and stiffness of the guiding body, and of the frame with which it is connected.

18. **Centrifugal Force** (*A. M.*, 538) is the force with which a revolving body reacts on the body that guides it, and is equal and opposite to the deviating force with which the guiding body acts on the revolving body.

In fact, as has been already stated, every force is an action between two bodies; and *deviating force* and *centrifugal force* are but two different names for the same force, applied to it according as the condition of the revolving body or that of the guiding body is under consideration at the time.

19. **A Revolving Pendulum** is one of the simplest practical applications of the principles of deviating force, and is described here because its use in regulating the speed of prime movers will afterwards have to be referred to. It consists of a ball A, suspended from a point C by a rod CA of small weight as compared with the ball, and revolving in a circle about a vertical axis AB. The tension of the rod is the resultant of the weight of the ball A, acting vertically, and of its centrifugal force, acting horizontally; and therefore the rod will assume such an inclination that

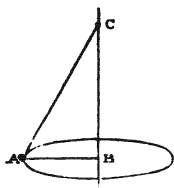

Fig. 7.

$$\frac{\text{height } \overline{BC}}{\text{radius } \overline{AB}} = \frac{\text{weight}}{\text{centrifugal force}} = \frac{gr}{v^2} \dots (1.)$$

where $r = AB$. Let T be the *number of turns per second* of the pendulum; then

$$v = 2\pi Tr;$$

and therefore, making $\overline{BC} = h$,

$$h = \frac{gr^2}{v^2} = \frac{g}{4\pi^2 T^2}$$

$$= (\text{in the latitude of London}) \frac{0.8154 \text{ foot}}{T^2} = \frac{9.7848 \text{ inches}}{T^2} \dots (2.)$$

20. **Deviating Force in Terms of Angular Velocity.** (*A. M.*, 540.) —When a body revolves in a circular path round a fixed axis, as is almost always the case with the revolving parts of machines, the radius of curvature of its path, being the perpendicular distance of the body from the axis, is constant; and the velocity v of the body is the product of that radius into the angular velocity; or symbolically, as in Article 5—

$$v = ar = 2\pi Tr.$$

If these values of the velocity be substituted for v in equation 1 of Article 17, it becomes—

$$Q = \frac{W a^2 r}{g} = \frac{W \cdot 4 \pi^2 T^2 r}{g} \dots\dots\dots(1.)$$

21. **Resultant Centrifugal Force.** (*A. M.*, 603.)—The whole centrifugal force of a body of any figure, or of a system of connected bodies, rotating about an axis, is the same in *amount* and *direction* as if the whole mass were concentrated at the centre of gravity of the system. That is to say, in the formula of Article 20, *W* is to be held to represent the weight of the whole body or system, and *r* the perpendicular distance of its centre of gravity from the axis; and the line of action of the resultant centrifugal force *Q* is always *parallel* to *r*, although it does not in every case *coincide* with *r*.

When the axis of rotation *traverses* the centre of gravity of the body or system, the amount of the centrifugal force is *nothing*; that is to say, the rotating body does not tend to pull its axis as a whole out of its place.

The centrifugal forces exerted by the various rotating pieces of a machine against the bearings of their axles are to be taken into account in determining the lateral pressures which cause friction, and the strength of the axles and framework.

As those centrifugal forces cause increased friction and stress, and sometimes, also, by reason of their continual change of direction, produce detrimental or dangerous vibration, it is desirable to reduce them to the smallest possible amount; and for that purpose, unless there is some special reason to the contrary, the axis of rotation of every piece which rotates rapidly ought to traverse its centre of gravity, that the resultant centrifugal force may be nothing.

22. **Centrifugal Couple—Permanent Axis.**—It is not, however, sufficient to annul the effect of centrifugal force, that there should be no tendency to *shift* the axis as a whole; there should also be no tendency to *turn* it into a new angular position.

To show, by the simplest possible example, that the latter tendency may exist without

the former, let the axis of rotation of the system shown in fig. 8 be the centre line of an axle resting in bearings at *E* and *F*. At *B* and *D* let two arms project perpendicularly to that axle, in opposite directions in the same plane, carrying at their extremities two heavy bodies *A* and *C*. Let the weights of the arms be

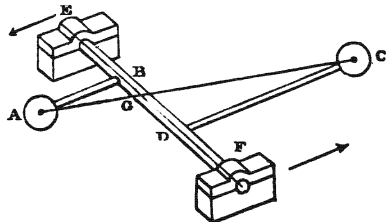

Fig. 8.

insensible as compared with the weights of those bodies; and let the weights of the bodies be inversely as their distances from the axis; that is, let

$$A \cdot \overline{AB} = C \cdot \overline{CD}.$$

Let AC be a straight line joining the centres of gravity of A and C, and cutting the axis in G; then G is the common centre of gravity of A and C, and being in the axis, the resultant centrifugal force is nothing.

In other words, let a be the angular velocity of the rotation; then

The centrifugal force exerted on the axis by A

$$= \frac{a^2 A \cdot \overline{AB}}{g};$$

The centrifugal force exerted on the axis by C

$$= \frac{a^2 C \cdot \overline{CD}}{g};$$

and those forces are equal in magnitude and opposite in direction; so that there is no tendency to remove the point G in any direction.

There is, however, a tendency to *turn the axis about* the point G, being the product of the common magnitude of the *couple* of centrifugal forces above stated, into their leverage; that is, the perpendicular distance \overline{BD} between their lines of action. That product is called *the moment of the centrifugal couple*; and is represented by

$$Q \cdot \overline{BD}; \dots \dots \dots (1.)$$

Q being the common magnitude of the equal and opposite centrifugal forces.

That couple causes a couple of equal and opposite pressures of the journals of the axle against their bearings at E and F, in the directions represented by the arrows, and of the magnitude given by the formula—

$$Q \cdot \frac{\overline{BD}}{\overline{EF}}; \dots \dots \dots (2.)$$

these pressures continually change their directions as the bodies A and C revolve; and they are resisted by the strength and rigidity of the bearings and frame. It is desirable, when practicable, to reduce them to nothing; and for that purpose, the points B, G, and D should coincide; in which case the centre line of the axle EF is said to be a *permanent axis*.

When there are more than two bodies in the rotating system, the centrifugal couple is found as follows:—

Let XX' , fig. 9, represent the axis of rotation; G , the centre of gravity of the rotating body or system, situated in that axis; so that the resultant centrifugal force is nothing.

Let W be any one of the parts of which the body or system is composed, so that, the weight of that part being denoted by W , the weight of the whole body or system may be denoted by $\Sigma \cdot W$.

Let r denote the perpendicular distance of the centre of W from the axis; then

$$\frac{W a^2 r}{g},$$

is the centrifugal force of W , pulling the axis in the direction xW .

Assume a pair of axes of co-ordinates, GZ , GY , perpendicular to XX' and to each other, and fixed relatively to the rotating body or system—that is, rotating along with it.

From W let fall \overline{Wy} perpendicular to the plane of GX and GY , and parallel to GZ ; also \overline{Wz} , perpendicular to the plane of GX and GZ , and parallel to GY ; and make

$$\overline{xy} = \overline{Wz} = y; \quad \overline{xz} = \overline{Wy} = z; \quad \overline{Gx} = x.$$

Then the centrifugal force which W exerts on the axis, and which is proportional to r , may be resolved into two components, in the direction of, and proportional to, y and z respectively, viz:—

$$\frac{W a^2 y}{g} \text{ parallel to } GY, \text{ and}$$

$$\frac{W a^2 z}{g} \text{ parallel to } GZ;$$

and those two component forces, being both applied at the end of the lever $Gx = x$, exert *moments*, or tendencies to turn the axis XX' about the point Z , expressed as follows:—

$$\frac{W a^2 y x}{g}, \text{ tending to turn } GX \text{ about } GZ \text{ towards } GY;$$

$$\frac{W a^2 z x}{g}, \text{ tending to turn } GX \text{ about } GY \text{ towards } GZ.$$

In the same manner are to be found the several moments of the

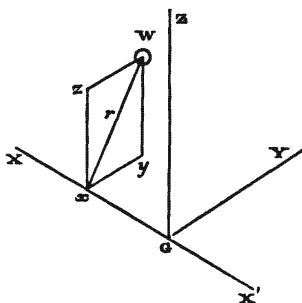

Fig. 9.

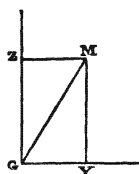

Fig. 10.

centrifugal forces of all the other parts of which the body or system consists; and care is to be taken to distinguish moments which tend to turn the axis *towards* G Y or G Z from those which tend to turn it *from* those positions, by treating one of these classes of quantities as positive, and the other as negative.

Then by adding together the positive moments and subtracting the negative moments for all the parts of the body or system, are to be found the two sums,

$$\frac{a^2}{g} \cdot \Sigma \cdot W y x; \frac{a^2}{g} \cdot \Sigma \cdot W z x; \dots \dots \dots (3.)$$

which represent the total tendencies of all the centrifugal forces to turn the axis in the planes of G Y and G Z respectively.

In fig. 10, lay down $\overline{G Y}$ to represent the former moment, and $\overline{G Z}$, perpendicular to G Y, to represent the latter. Then the diagonal $\overline{G M}$ of the rectangle G Z M Y will represent the resultant moment of what is called the CENTRIFUGAL COUPLE, and the direction of that line will indicate the direction in which that couple tends to turn the axis G X about the point G. Its value, and its angular position, are given by the equations,

$$\left. \begin{aligned} \overline{G M} &= \sqrt{(\overline{G Y}^2 + \overline{G Z}^2)}; \\ \tan \angle Y G M &= \overline{G Z} \div \overline{G Y} \end{aligned} \right\} \dots \dots \dots (4.)$$

The condition which it is desirable to fulfil in all rapidly rotating pieces of machines, that the axis of rotation shall be a *permanent axis*, is fulfilled when each of the sums in the formula 3 is nothing; that is, when

$$\Sigma \cdot W y x = 0 \cdot \Sigma \cdot W z x = 0, \dots \dots \dots (5.)$$

The question, whether the axis of a rotating piece is a permanent axis or not, is tested experimentally by making the piece spin round rapidly with its shaft resting in bearings which are suspended by chains or cords, so as to be at liberty to swing to and fro. If the axis is not a permanent axis, it oscillates; if it is a permanent axis, it remains steady.

The practical application of those principles to locomotive engines will be explained in the sequel.

SECTION 3.—Of Effort, Energy, Power, and Efficiency.

23. **Effort** is a name applied to a force which acts on a body in the direction of its motion (*A. M.*, 511).

If a force is applied to a body in a direction making an acute

angle with the direction of the body's motion, the component of that oblique force along the direction of the body's motion is an effort. That is to say, in fig. 11, let AB represent the direction in which A is moving; let \overline{AF} represent a force applied to A , obliquely to that direction; from F draw \overline{FP} perpendicular to AB ; then \overline{AP} is the effort due to the force \overline{AF} . The transverse component \overline{PF} is a lateral force, like the transverse component of the oblique resisting force in Article 8.

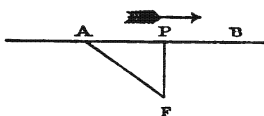

Fig. 11.

To express this algebraically, let the entire force $\overline{AF} = F$, the effort $\overline{AP} = P$, the lateral force $\overline{PF} = Q$, and the angle of obliquity $\angle PAF = \theta$. Then

$$\left. \begin{aligned} P &= F \cdot \cos \theta; \\ Q &= F \cdot \sin \theta \end{aligned} \right\} \dots\dots\dots(1.)$$

24. Condition of Uniform Speed. (*A. M.*, 510, 512, 537.)—According to the first law of motion, in order that a body may move uniformly, the forces applied to it, if any, must balance each other; and the same principle holds for a machine consisting of any number of bodies.

When the *direction* of a body's motion varies, but not the *velocity*, the lateral force required to produce the change of direction depends on the principles set forth in Section 2; but the condition of balance still holds for the forces which act *along* the direction of the body's motion, that is, for the *efforts* and *resistances*; so that, whether for a single body or for a machine, the condition of *uniform velocity* is, that the *efforts shall balance the resistances*.

In a machine, this condition must be fulfilled for each of the single moving pieces of which it consists.

It can be shown from the principles of statics (that is, the science of balanced forces), that in any body, system, or machine, that condition is fulfilled when the *sum of the products of the efforts into the velocities of their respective points of action is equal to the sum of the products of the resistances into the velocities of the points where they are overcome*.

Thus, let v be the velocity of a *driving point*, or point where an effort P is applied; v' the velocity of a *working point*, or point where a resistance R is overcome; the condition of uniform velocity for any body, system, or machine is

$$\sum P v = \sum R v' \dots\dots\dots(1.)$$

If there be only one driving point, or if the velocities of all the

driving points be alike, then P being the total effort, the single product $P v$ may be put in in place of the sum $\Sigma \cdot P v$; reducing the above equation to

$$P v = \Sigma \cdot R v' \dots\dots\dots ..(2.)$$

Referring now to Article 9, let the machine be one in which the *comparative or proportionate* velocities of all the points at a given instant are known independently of their absolute velocities, from the construction of the machine; so that, for example, the velocity of the point where the resistance R is overcome bears to that of the driving point the ratio

$$\frac{v'}{v} = n;$$

then the condition of uniform speed may be thus expressed:—

$$P = \Sigma \cdot n R; \dots\dots\dots (3.)$$

that is, *the total effort is equal to the sum of the resistances reduced to the driving point.*

25. **Energy—Potential Energy.** (*A. M.*, 514, 517, 593, 660.)—*Energy* means *capacity for performing work*, and is expressed, like work, by the product of a force into a space.

The energy of an effort, sometimes called “*potential energy*” (to distinguish it from another form of energy to be afterwards referred to), is the *product of the effort into the distance through which it is capable of acting*. Thus, if a weight of 100 pounds be placed at an elevation of 20 feet above the ground, or above the lowest plane to which the circumstances of the case admit of its descending, that weight is said to possess potential energy to the amount of $100 \times 20 = 2,000$ *foot-pounds*; which means, that in descending from its actual elevation to the lowest point of its course, the weight is *capable of performing work* to that amount.

To take another example, let there be a reservoir containing 10,000,000 gallons of water, in such a position that the centre of gravity of the mass of water in the reservoir is 100 feet above the lowest point to which it can be made to descend while overcoming resistance. Then as a gallon of water weighs 10 lbs., the weight of the store of water is 100,000,000 lbs., which being multiplied by the height through which that weight is capable of acting, 100 feet, gives 10,000,000,000 *foot-pounds* for the potential energy of the weight of the store of water.

36. **Equality of Energy Exerted and Work Performed.**—When an effort actually does drive its point of application through a certain distance, energy to the amount of the product of the effort into that distance is said to be *exerted*; and the potential energy,

or energy which remains *capable of being exerted*, is to that amount diminished.

When the energy is exerted in driving a machine at an uniform speed, it is *equal to the work performed*.

To express this algebraically, let t denote the time during which the energy is exerted, v the velocity of a driving point at which an effort P is applied, s the distance through which it is driven, v' the velocity of any working point at which a resistance R is overcome, s' the distance through which it is driven; then

$$s = v t; s' = v' t;$$

and multiplying equation 1 of Article 24 by the time t , we obtain the following equation :—

$$\Sigma \cdot P v t = \Sigma \cdot R v' t = \Sigma \cdot P s = \Sigma \cdot R s'; \dots \dots (1.)$$

which expresses the equality of energy exerted, and work performed, for constant efforts and resistances.

When the efforts and resistances vary, it is sufficient to refer to Article 11 to show, that the same principle is expressed as follows :—

$$\Sigma \int P ds = \Sigma \int R ds'; \dots \dots (2.)$$

where the symbol \int expresses the operation of finding the work performed against a varying resistance, or the energy exerted by a varying effort, as the case may be; and the symbol Σ expresses the operation of adding together the quantities of energy exerted, or work performed, as the case may be, at different points of the machine.

27. Various Factors of Energy.—A quantity of energy, like a quantity of work, may be computed by multiplying either a force into a distance, or a statical moment into an angular motion, or the intensity of a pressure into a volume. These processes have already been explained in detail in Articles 5 and 6.

28. The Energy Exerted in Producing Acceleration (*A. M.*, 549) is equal to the work of acceleration, whose amount has been investigated in Articles 14 A and 15.

29. The Accelerating Effort (*A. M.*, 554) by which a given increase of velocity in a given mass is produced, and which is exerted by the *driving body* against the *driven body*, is equal and opposite to the resistance due to acceleration which the driven body exerts against the driving body, and whose amount has been given in Articles 14 A and 15. Referring, therefore, to equations 4 and 8 of Article 14 A, we find the two following expressions, the first of which gives the accelerating effort required to produce a given

acceleration $d v$ in a body whose weight is W , when the *time* $d t$ in which that acceleration is to be produced is given, and the second, the same accelerating effort, when the *distance* $d s = v d t$ in which the acceleration is to be produced is given :—

$$P = \frac{W}{g} \cdot \frac{d v}{d t} \dots\dots\dots(1.)$$

$$= \frac{W}{g} \cdot \frac{v d v}{d s} = \frac{W}{g} \cdot \frac{d (v^2)}{2 d s} \dots\dots\dots(2.)$$

Referring next to Article 15, case 1, we find from equations 5, 6, and 7, that the work of acceleration corresponding to an increase $d a$ in the angular velocity of a rotating body whose moment of inertia is I , is

$$\frac{I \cdot d (a^2)}{2 g} = \frac{I a d a}{g}.$$

Let $d t$ be the *time*, and $d i = a d t$ the *angular motion* in which that acceleration is to be produced; let P be the accelerating effort, and l its *leverage*, or the perpendicular distance of its line of action from the axis; then, according as the time $d t$, or the angle $d i$, is given, we have the two following expressions for the *accelerating couple* :—

$$P l = \frac{I}{g} \cdot \frac{d a}{d t} \dots\dots\dots(3.)$$

$$= \frac{I}{g} \cdot \frac{a d a}{d i} = \frac{I}{g} \cdot \frac{d (a^2)}{2 d i} \dots\dots\dots(4.)$$

Lastly, referring to Article 15, case 2, equation 9, we find, that if a train of mechanism consists of various parts, and if W be the weight of any one of those parts, whose velocity v' bears to that of the driving point v the ratio $\frac{v'}{v} = n$, then the accelerating effort which must be applied to the driving point, in order that, during the interval $d t$, in which the driving point moves through the distance $d s = v d t$, that point may undergo the acceleration $d v$, and each weight W the corresponding acceleration $n d v$, is given by one or other of the two formulæ—

$$P = \frac{\Sigma n^2 W}{g} \cdot \frac{d v}{d t} \dots\dots\dots(5.)$$

$$= \frac{\Sigma n^2 W}{g} \cdot \frac{v d v}{d s} = \frac{\Sigma n^2 W}{g} \cdot \frac{d (v^2)}{2 d s} \dots\dots\dots(6.)$$

30. **Work During Retardation—Energy Stored and Restored.** (*A. M.*, 528, 549, 550.)—In order to cause a given retardation, or diminution of the velocity of a given body, in a given time, or while it traverses a given distance, resistance must be opposed to its motion equal to the effort which would be required to produce in the same time, or in the same distance, an acceleration equal to the retardation.

A moving body, therefore, while being retarded, *overcomes resistance* and *performs work*; and that work is equal to the energy exerted in producing an acceleration of the same body equal to the retardation.

It is for this reason that it has been stated, in Article 12, that the work performed in accelerating the speed of the moving pieces of a machine is not necessarily lost; for those moving pieces, by returning to their original speed, are capable of performing an equal amount of work in overcoming resistance; so that the performance of such work is not prevented, but only deferred. Hence energy exerted in acceleration is said to be *stored*; and when by a subsequent and equal retardation an equal amount of work is performed, that energy is said to be *restored*.

The algebraical expressions for the relations between a retarding resistance, and the retardation which it produces in a given body by acting during a given time or through a given space, are obtained from the equations of Article 29 simply by putting *R*, the symbol for a resistance, instead of *P*, the symbol for an effort, and $-dv$, the symbol for a retardation, instead of dv , the symbol for an acceleration.

31. The **Actual Energy** (*A. M.*, 547, 589) of a moving body is the work which it is capable of performing against a retarding resistance before being brought to rest, and is equal to the energy which must be exerted on the body to bring it from a state of rest to its actual velocity. The value of that quantity is the *product of the weight of the body into the height from which it must fall to acquire its actual velocity*; that is to say,

$$\frac{W v^2}{2g} \dots\dots\dots(1.)$$

The total actual energy of a system of bodies, each moving with its own velocity, is denoted by

$$\frac{\Sigma \cdot W v^2}{2g} ; \dots\dots\dots(2.)$$

and when those bodies are the pieces of a machine, whose velocities

bear definite ratios (any one of which is denoted by n) to the velocity of the driving point v , their total actual energy is

$$\frac{v^2}{2g} \cdot \sum n^2 W, \dots \dots \dots (3.)$$

being *the product of the reduced inertia* (or co-efficient of steadiness, as Mr. Moseley calls it) *into the height due to the velocity of the driving point.*

The actual energy of a rotating body whose angular velocity is a , and moment of inertia $\sum W r^2 = I$, is

$$\frac{a^2 I}{2g}; \dots \dots \dots (4.)$$

that is, *the product of the moment of inertia into the height due to the velocity, a , of a point, whose distance from the axis of rotation is unity.*

When a given amount of energy is alternately stored and re-stored by alternate increase and diminution in the speed of a machine, the actual energy of the machine is alternately increased and diminished by that amount.

Actual energy, like motion, is *relative* only. That is to say, in computing the actual energy of a body, which is the capacity it possesses of performing work upon certain other bodies by *reason of its motion*, it is the motion *relatively to those other bodies* that is to be taken into account.

For example, if it be wished to determine how many turns a wheel of a locomotive engine, rotating with a given velocity, would make, before being stopped *by the friction of its bearings only*, supposing it lifted out of contact with the rails,—the actual energy of that wheel is to be taken *relatively to the frame of the engine* to which those bearings are fixed, and is simply the actual energy due to the rotation. But if the wheel be supposed to be detached from the engine, and it is inquired *how high it will ascend up a perfectly smooth inclined plane before being stopped by the attraction of the earth*, then its actual energy is to be taken *relatively to the earth*; that is to say, to the energy of rotation already mentioned, is to be added the energy due to the *translation* or forward motion of the wheel along with its axis.

32. **A Reciprocating Force** (*A. M.*, 556) is a force which acts alternately as an effort and as an equal and opposite resistance, according to the direction of motion of the body. Such a force is the weight of a moving piece whose centre of gravity alternately rises and falls; and such is the elasticity of a perfectly elastic body

The work which a body performs in moving against a reciprocating force is employed in increasing its own potential energy, and is not lost by the body; so that by the motion of a body alternately against and with a reciprocating force, energy is *stored* and *restored*, as well as by alternate acceleration and retardation.

Let ΣW denote the weight of the whole of the moving pieces of any machine, and h a height through which the common centre of gravity of them all is alternately raised and lowered. Then the quantity of energy—

$$h \Sigma W,$$

is stored while the centre of gravity is rising, and restored while it is falling.

These principles are illustrated by the action of the plungers of a single acting pumping steam engine. The weight of those plungers acts as a resistance while they are being lifted by the pressure of the steam on the piston; and the same weight acts as effort when the plungers descend and drive before them the water with which the pump barrels have been filled. Thus, the energy exerted by the steam on the piston is stored during the up-stroke of the plungers; and during their down-stroke the same amount of energy is restored, and employed in performing the work of raising water and overcoming its friction.

33. Periodical Motion. (*A. M.*, 553.)—If a body moves in such a manner that it periodically returns to its original velocity, then at the end of each period, the entire variation of its actual energy is nothing; and if, during any part of the period of motion, energy has been stored by acceleration of the body, the same quantity of energy exactly must have been during another part of the period restored by retardation of the body.

If the body also returns in the course of the same period to the same position relatively to all bodies which exert reciprocating forces on it—for example, if it returns periodically to the same elevation relatively to the earth's surface—any quantity of energy which has been stored during one part of the period by moving against reciprocating forces must have been exactly restored during another part of the period.

Hence *at the end of each period, the equality of energy and work, and the balance of mean effort and mean resistance, holds with respect to the driving effort and the resistances, exactly as if the speed were uniform and the reciprocating forces null*; and all the equations of Articles 24 and 26 are applicable to periodic motion, provided that in the equations of Article 24, and equation 1 of Article 26, P , R , and v are held to denote the *mean values* of the efforts, resistances, and velocities,—that s and s' are held to denote spaces moved through in one or more *entire periods*,—and that in equa-

tion 2 of Article 26, the integrations denoted by \int be held to extend to one or more *entire periods*.

These principles are illustrated by the steam engine. The velocities of its moving parts are continually varying, and those of some of them, such as the piston, are periodically reversed in direction. But at the end of each period, called a *revolution*, or *double-stroke*, every part returns to its original position and velocity; so that the *equality of energy and work*, and the *equality of the mean effort to the mean resistance reduced to the driving point*,—that is, the equality of the mean effective pressure of the steam on the piston to the mean total resistance reduced to the piston—hold for one or any whole number of *complete revolutions*, exactly as for uniform speed.

It thus appears that there are two fundamentally different ways of considering a periodically moving machine, each of which must be employed in succession, in order to obtain a complete knowledge of its working.

I. In the first place is considered the action of the machine during one or more whole periods, with a view to the determination of the relation between the mean resistances and mean efforts, and of the *EFFICIENCY*; that is, the ratio which the *useful* part of its work bears to the whole expenditure of energy. The motion of every ordinary machine is either uniform or periodical.

II. In the second place is to be considered the action of the machine during intervals of time less than its period, in order to determine the law of the periodic changes in the motions of the pieces of which the machine consists, and of the periodic or reciprocating forces by which such changes are produced.

34. *Starting and Stopping.* (*A. M.*, 691.)—The *starting* of a machine consists in setting it in motion from a state of rest, and bringing it up to its proper mean velocity. This operation requires the exertion, besides the energy required to overcome the mean resistance, of an additional quantity of energy equal to the actual energy of the machine when moving with its mean velocity, as found according to the principles of Article 31.

If, in order to *stop* a machine, the effort of the prime mover is simply suspended, the machine will continue to go until work has been performed in overcoming resistances equal to the actual energy due to the speed of the machine at the time of suspending the effort of the prime mover.

In order to diminish the time required by this operation, the resistance may be increased by means of the friction of a *brake*. Brakes will be further described in the sequel.

35. The *Efficiency* of a machine (*A. M.*, 660, 664) has already

been defined to be a fraction expressing the ratio of the useful work to the whole work performed, which is equal to the energy expended. The limit to the efficiency of a machine is *unity*, denoting the efficiency of a perfect machine in which no work is lost. The object of improvements in machines is to bring their efficiency as near to unity as possible.

As to useful and lost work, see Article 12. The algebraical expression of the efficiency of a machine having uniform or periodical motion, is obtained by introducing the distinction between useful and lost work into the equations of the conservation of energy. Thus, let P denote the mean effort at the driving point, s the space described by it in a given interval of time, being a whole number of periods or revolutions, R , the mean useful resistance, s_1 the space through which it is overcome in the same interval, R_2 , any one of the prejudicial resistances, s_2 the space through which it is overcome; then

$$P s = R_1 s_1 + \Sigma \cdot R_2 s_2; \dots\dots\dots(1.)$$

and the efficiency of the machine is expressed by

$$\frac{R_1 s_1}{P s} = \frac{R_1 s_1}{R_1 s_1 + \Sigma \cdot R_2 s_2} \dots\dots\dots(2.)$$

In many cases the lost work of a machine, $R_2 s_2$, consists of a constant part, and of a part bearing to the useful work a proportion depending in some definite manner on the sizes, figures, arrangement, and connection of the pieces of the train, on which also depends the constant part of the lost work. In such cases the whole energy expended and the efficiency of the machine are expressed by the equations

$$\left. \begin{aligned} P s &= (1 + A) R_1 s_1 + B; \\ \frac{R_1 s_1}{P s} &= \frac{1}{1 + A + \frac{B}{R_1 s_1}} \end{aligned} \right\} \dots\dots\dots(3.)$$

and the first of these is the mathematical expression of what Mr. Moseley calls the "modulus" of a machine.

The useful work of an intermediate piece in a train of mechanism consists in driving the piece which follows it, and is less than the energy exerted upon it by the amount of the work lost in overcoming its own friction. Hence the efficiency of such an intermediate piece is the ratio of the work performed by it in driving the following piece, to the energy exerted on it by the preceding piece; and it is evident that *the efficiency of a machine is the product of the efficiencies of the series of moving pieces which transmit energy from the driving point to the working point.*

The same principle applies to a train of *successive machines*, each driving that which follows it.

36. Power and Effect—Horse-Power.—The *power* of a machine is the energy exerted, and the *effect*, the useful work performed, in some interval of time of definite length, such as a second, a minute, an hour, or a day.

The unit of power called conventionally a *horse-power*, is 550 foot-pounds per second, or 33,000 foot-pounds per minute, or 1,980,000 foot-pounds per hour. The effect is equal to the power multiplied by the efficiency. The loss of power is the difference between the effect and the power. (See also Article 3.)

37. General Equation.—The following general equation presents at one view the principles of the action of machines, whether moving uniformly, periodically, or otherwise:—

$$\int P ds = z \int R ds' \pm h z W + z \cdot \frac{W (v_2^2 - v_1^2)}{2g}$$

where W is the weight of any moving piece of the machine ;

h , when positive, the elevation, and when negative, the depression, which the common centre of gravity of all the moving pieces undergoes in the interval of time under consideration ; v_1 the velocity at the beginning, and v_2 the velocity at the end, of the interval in question, with which a given particle of the machine of the weight W is moving ;

g , the acceleration which gravity causes in a second, or 32.2 feet per second ;

$\int R ds'$, the work performed in overcoming any resistance during the interval in question ;

$\int P ds$, the energy exerted during the interval in question.

The second and third terms of the right hand side, when positive, are *energy stored* ; when negative, *energy restored*.

The principle represented by the equation is expressed in words as follows:—

The energy exerted, added to the energy restored, is equal to the energy stored added to the work performed.

SECTION 4.—Of Dynamometers.

38. Dynamometers are instruments for measuring and recording the energy exerted and work performed by machines. They may be classed as follows:—

I. Instruments which merely *indicate the force* exerted between a driving body and a driven body, leaving the *distance* through

which that force is exerted to be observed independently. The following are examples of this class:—

a. The weight of a solid body may be so suspended as to balance the resistance to be overcome, as in Mr. Scott Russell's experiments on the resistance of canal boats, published in the *Transactions of the Royal Society of Edinburgh*, vol. xiv.

b. The weight of a column of liquid may be employed to balance and measure the effort required to drag a carriage or other body, as in the mercurial dynamometer invented by Mr. John Milne of Edinburgh.

c. The available energy of a prime mover may be wholly expended in overcoming friction, the magnitude of which is measured by a weight, as in Prony's dynamometer, to be afterwards more particularly described.

d. A spring balance may be interposed between a prime mover and a body whose resistance it overcomes, so as to indicate at each instant the magnitude of that resistance.

II. Instruments which *record* at once the *force*, *motion*, and *work* of a machine, by drawing a line, straight or curved, as the case may be (such as that shown in fig. 3, Article 11) whose abscissæ represent on a suitable scale the distances moved through, its ordinates the corresponding resistances overcome, and its area the work performed.

A dynamometer of this class consists essentially of two principal parts: a spring whose deflection indicates the force exerted between a driving body and a driven body, and a band of paper, or a card, moving at right angles to the direction of deflection of the spring with a velocity bearing a known constant proportion to the velocity with which the resistance is overcome. The spring carries a pen or pencil, which marks on the paper or card the required line. The following examples of this class of instruments will be described in the sequel:—

- a. Morin's Traction Dynamometer.
- b. Morin's Rotatory Dynamometer.
- c. Watt and M'Naught's Steam Engine Indicator.

III. Instruments which record the work performed, but not the resistance and motion separately.

39. **Prony's Friction Dynamometer** measures the useful work performed by a prime mover, by causing the whole of that work to be expended in overcoming the friction of a brake. In fig. 12, A represents a cylindrical drum, driven by the prime mover. The block D, attached to the lever BC, and the

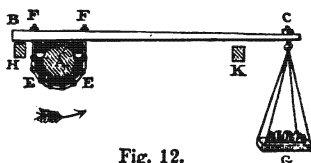

Fig. 12.

smaller blocks with which the chain E is shod, form a brake which embraces the drum, and which is tightened by means of the screws F, F, until its friction is sufficient to cause the drum to rotate at an uniform speed. The end C of the lever carries a scale G, in which weights are placed to an amount just sufficient to balance the friction, and keep the lever horizontal. The lever ought to be so loaded at B that when there are no weights in the scale, it shall be balanced upon the axis. The lever is prevented from deviating to any inconvenient extent from a horizontal position by means of safety stops or guards H, K.

The weight of the load in the scale which balances the friction being multiplied into the horizontal distance of the point of suspension C from the axis, gives the *moment of friction*, which being multiplied into the angular velocity of the drum, gives the *rate of useful work* or *effective power* of the prime mover.

As the whole of that power is expended in overcoming the friction between the drum and the brake, the heat produced is in general considerable; and a stream of water must be directed on the rubbing surfaces to abstract that heat.

The friction dynamometer is simple and easily made; but it is ill adapted to measure a variable effort; and it requires that when the power of a prime mover is measured, its ordinary work should be interrupted, which is inconvenient and sometimes impracticable.

40. *Morin's Traction Dynamometer*.—The descriptions of this and some other dynamometers invented by General Morin are abridged from his works entitled *Sur quelques Appareils dynamométriques* and *Notions fondamentales de Mécanique*.

Fig. 13 is a plan and fig. 13 a an elevation of a dynamometer for recording by a diagram the work of dragging a load horizontally. *a a*, *b b*, are a pair of steel springs, through which the tractive force is transmitted, and which serve by their deflection to measure that force. They are connected together at the ends by the steel links *f, f*. The effort of the prime mover is applied, through the link *r*, to the gland *d*, which is fixed on the middle of the foremost spring; the equal and opposite resistance of the vehicle is applied to the gland *c*, which is fixed on the middle of the aftermost spring. When no tractive force is exerted, the inward faces of the springs are straight and parallel; when a force is exerted, the springs are bent, and are drawn apart, through a distance proportional to the force. The springs are protected against being bent so far as to injure them by means of the safety bridles *i, i*, with their bolts *e, e*. Those bridles are carried by the after-gland, and their bolts serve to stop the foremost spring when it is drawn forward as far as is consistent with the preservation of elasticity and strength.

The frame of the apparatus for giving motion to the paper band

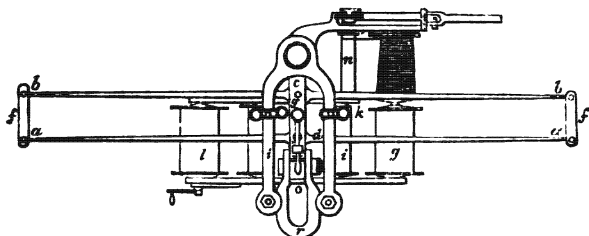

Fig. 13.

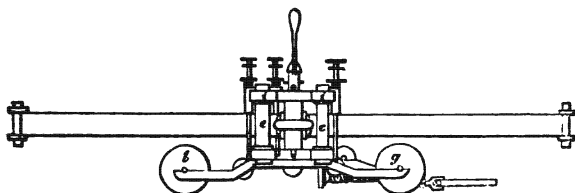

Fig. 13 a.

is carried by the after-gland. The principal parts of that apparatus are the following:—

l, store drum on which the paper band is rolled before the commencement of the experiment, and off which it is drawn as the experiment proceeds;

g, taking-up drum, to which one end of the paper band is glued, and which draws along and rolls up the paper band with a velocity proportional to that of the vehicle. Fixed on the axis of this drum is a fusee having a spiral groove round it, whose radius gradually increases at the same rate as that at which the effective radius of the drum *g* is increased during its motion by the rolling of successive coils of paper upon it. The object of this is to prevent that increase of the effective radius of the drum from accelerating the speed of the paper band;

n is a drum which receives through a train of wheelwork and endless screws, a velocity proportional to that of the wheels of the vehicle, and which, by means of a cord, drives the fusee. The mechanism is usually so designed that the paper moves at one-fiftieth of the speed of the vehicle.

Between the drums *l* and *g*, there are three small rollers to support the paper band and keep it steady.

One of the safety bridles carries a pencil *k*, which, being at rest

relatively to the frame of the recording apparatus, traces a straight line on the band of paper as the latter travels below the pencil. That line is called the *zero line*, and corresponds to O X in fig. 3.

An arm fixed to the forward gland carries another pencil, whose position is adjusted before the experiment, so that when there is no tractive force its point rests on the zero line. During the experiment, this pencil traces on the paper band a line such as E R G, fig. 3, whose ordinate or distance from any given point in the zero line is the deflection of the pair of springs, and proportional to the tractive force, at the corresponding point in the journey of the vehicle.

The areas of the diagrams drawn by this apparatus, representing quantities of work, may be found either by the method described in Articles 11, 11A, or by an instrument for measuring the areas of plane figures, called the *Planimeter*, of which various forms have been invented by M. Ernst, Mr. Edward Sang, and Professor Clerk Maxwell.

A third pencil, actuated by a clock, is sometimes caused to mark a series of dots on the paper band at equal intervals of time, and so to record the changes of velocity.

When one vehicle (such as a locomotive engine) drags one or more others, the apparatus may, if convenient, be turned hind side before, and carried by the foremost vehicle. In such a case the motion of the band of paper ought to be derived, not from a driving wheel, which is liable to slip, but from a training wheel.

When the apparatus is used to record the tractive force and work performed in towing a vessel, the apparatus for moving the paper band may be driven by means of a wheel or fan, acted upon by the water; in which case, the ratio of the velocity of the band to that of the vessel should be determined by experiment.

Owing to the varieties which exist in the elasticity of steel, the relation between the deflections of the springs and the tractive forces can only be roughly calculated beforehand, and should be determined exactly by direct experiment—that is, by hanging known weights to the springs and noting the deflections.

The best form of longitudinal section for each spring is that which gives the greatest flexibility for a given strength, and consists of two parabolas, having their vertices at the two ends of the spring, and meeting base to base in the middle—that is to say, the thickness of the spring at any given point of its length should be proportional to the square root of the distance of that point from the nearest end of the spring. To express this by a formula, let

c be the half-length of the spring;

h the thickness in the middle;

x the distance of any point in the spring from the end nearest to it;

h' the thickness at that point; then

$$h' = h \cdot \sqrt{\frac{x}{c}} \dots \dots \dots (1.)$$

The breadth of each spring should be uniform, and, according to General Morin, should not exceed from $1\frac{1}{2}$ to 2 inches. Let it be denoted by b .

The following is the formula for calculating beforehand the *probable* joint deflection of a given pair of springs under a given tractive force:—

Let the dimensions c, h, b , be stated in inches, and the force P in pounds.

Let y denote the deflection in inches.

Let E denote the *modulus of elasticity* of steel, in pounds on the square inch. Its value, for different specimens of steel, varies from 29,000,000 to 42,000,000, the smaller values being the most common. Then

$$y = \frac{8 P c^3}{E b h^3} \dots \dots \dots (2.)$$

The deflection should not be permitted to exceed about one-tenth part of the length of the springs.

41. **Morin's Rotatory Dynamometer** is represented in figs. 14, 14 a,

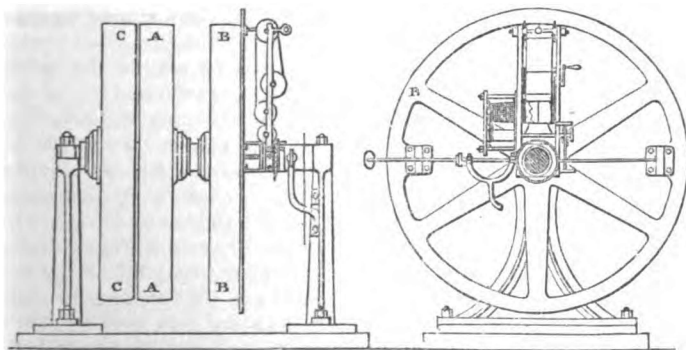

Fig. 14.

Fig. 14 a.

and is designed to record the work performed by a prime mover in transmitting rotatory motion to any machine. A is a fast pulley,

and C a loose pulley, on the same shaft. A belt transmits motion from the prime mover to one or other of those pulleys according as it is desired to transmit motion to the shaft or not.

A third pulley, B, on the same shaft, carries the belt which transmits motion to the machine to be driven. This pulley is also loose on the shaft to a certain extent, so that it is capable of moving relatively to the shaft, backwards and forwards through a small arc, sufficient to admit of the deflection of a steel spring by which motion is transmitted from the shaft to the pulley.

One end of that spring is fixed to the shaft, so that the spring projects from the shaft like an arm, and rotates along with it. The other end of the spring is connected with the pulley B near its circumference, and is the means of driving that pulley; so that the spring undergoes deflection proportional to the effort exerted by the shaft on the pulley.

A frame projecting radially like an arm from the shaft, and rotating along with it, carries an apparatus similar to that used in the traction dynamometer, for making a band of paper move radially with respect to the shaft with a velocity proportional to the speed with which the shaft rotates. A pencil carried by this frame traces a zero line on the paper band; and another pencil carried by the end of the spring, traces a line whose ordinates represent the forces exerted, just as in the traction dynamometer.

The mechanism for moving the paper band is driven by a toothed ring surrounding the shaft, and kept at rest while the shaft rotates by means of a catch. When that catch is drawn back, the toothed ring is set free, rotates along with the shaft, and ceases to drive the mechanism; and thus the motion of the paper band can be stopped if necessary.

42. **Merin's Integrating Dynamometers** record simply the work performed in dragging a vehicle or driving a machine, without recording separately the force and the motion. The general principle of the method by which this is effected is shown by fig. 15, in

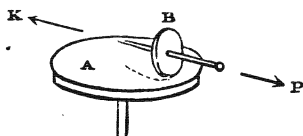

Fig. 15.

which A represents a plane circular disc, made to rotate with an angular velocity proportional to the speed of the motion of the vehicle or machine, and B a small wheel driven by the friction of the disc against its edge, and having its axis parallel to a radius of the disc. The wheel B,

and some mechanism which it drives, are carried by a frame which is carried by one of the dynamometer springs, and so adjusted that the distance of the edge of B from the centre of A is equal to the deflection of the springs, and proportional to the effort.

The velocity of the edge of B at any instant being the product of its distance from the centre of A into the angular velocity of A, is proportional to the product of the effort into the velocity of the vehicle or machine—that is, to the *rate at which work is performed*; therefore the motion of the wheel B, in any interval of time, is *proportional to the work performed in that time*; and that work can be recorded by means of dial plates, with indexes moved by a train of wheelwork driven by the wheel B.

43. Indicator—Application to the Steam Engine.—This instrument was invented by Watt, and has since been improved by other inventors, and especially by Mr. M'Naught. Its object is to record, by means of a diagram, the intensity of the pressure exerted by steam against one of the faces of a piston at each point of the piston's motion, and so to afford the means of computing, according to the principles of Article 6 and Article 11, first, the energy exerted by the steam in driving the piston during the forward stroke; secondly, the work lost by the piston in expelling the steam from the cylinder during the return stroke; and thirdly, the difference of these quantities, which is the *available* or *effective* energy exerted by the steam on the piston, and which, being multiplied by the number of strokes per minute and divided by 33,000 foot-pounds, gives the INDICATED HORSE-POWER.

The indicator in its present form is represented by fig. 16. A B is a cylindrical case. Its lower end A contains a small cylinder, fitted with a piston, which cylinder, by means of the screwed nozzle at its lower end, can be fixed in any convenient position on a tube communicating with that end of the engine cylinder where the work of the steam is determined. The communication between the engine cylinder and the indicator cylinder can be opened and shut at will by means of the cock K. When it is open, the intensity of the pressure of the steam on the engine piston and on the indicator piston is the same, or nearly the same.

The upper end B of the cylindrical case contains a spiral spring, one end of which is attached to the piston or to its rod, and the other to the top of the casing. The indicator piston is pressed from below by the steam, and from above by the atmosphere. When the pressure of the steam is equal to that of the atmosphere, the spring retains its unstrained length, and the piston its original position. When the pressure of the steam exceeds that of the atmosphere, the piston is driven outwards, and the spring com-

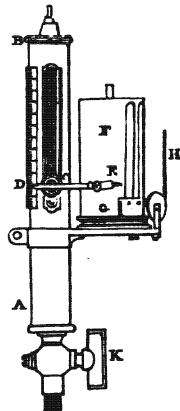

Fig. 16.

pressed; when the pressure of the steam is less than that of the atmosphere, the piston is driven inwards, and the spring extended. The compression or extension of the spring indicates the difference, upward or downward, between the pressure of the steam and that of the atmosphere.

A short arm C projecting from the indicator piston rod carries at one side a pointer D, which shows the pressure on a scale whose zero denotes the *pressure of the atmosphere*, and which is graduated into pounds on the square inch both upwards and downwards from that zero. At the other side, the short arm has a longer arm jointed to it, carrying a pencil E.

F is a brass drum, which rotates backward and forward about a vertical axis, and which, when about to be used, is covered with a piece of paper called a "card." It is alternately pulled round in one direction by the cord H, which wraps on the pulley G, and pulled back to its original position by a spring contained within itself. The cord H is to be connected with the mechanism of the steam engine in any convenient manner which shall insure that the velocity of rotation of the drum shall at every instant bear a constant ratio to that of the steam engine piston: the back and forward motion of the surface of the drum representing that of the steam engine piston on a reduced scale. This having been done, and before opening the cock K, the pencil is to be placed in contact with the drum during a few strokes, when it will mark on the card a line which, when the card is afterwards spread out flat, becomes a straight line. This line, whose position indicates the pressure of the atmosphere, is called the *atmospheric line*. In fig. 17, it is represented by A A.

Then the cock K is opened, and the pencil moving up and down with the variations of the pressure of the steam, traces on the card during each complete or double stroke a curve such as B C D E B. The ordinates drawn to that curve from any point in the atmospheric line, such as \overline{HK} and \overline{HG} , indicate the differences between the pressure of the steam and the atmospheric pressure at the corresponding point of the motion of the piston.

The ordinates of the part B C D E represent the pressures of the steam during the forward stroke, when it is driving the piston; those of the part E B represent the pressures of the steam when the piston is expelling it from the cylinder.

To found exact investigations on the indicator diagrams of steam

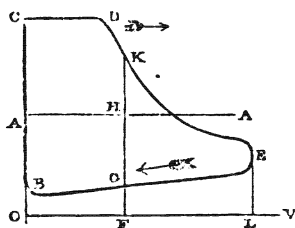

Fig. 17.

engines, the atmospheric pressure at the time of the experiment ought to be ascertained by means of a barometer; but this is generally omitted; in which case the atmospheric pressure may be assumed at its mean value, being 14.7 lbs. on the square inch, or 2116.4 lbs. on the square foot, at and near the level of the sea.

Let $\overline{AO} = \overline{HF}$ be ordinates representing the pressure of the atmosphere. Then OFV parallel to AA , is the *absolute* or *true* zero line of the diagram, corresponding to *no pressure*; and ordinates drawn to the curve from that line represent the absolute intensities of the pressure of the steam. Let OB and LE be ordinates touching the ends of the diagram; then

\overline{OL} represents the *volume* traversed by the piston at each single stroke ($= sA$, where s is the length of the stroke and A the area of the piston);

The area $OBCELO$ represents the energy exerted by the steam on the piston during the forward stroke;

The area $OBEL$ represents the work lost in expelling the steam during the back stroke;

The area $BCEB$, being the difference of the above areas, represents the *effective work* of the steam on the piston, during the complete stroke.

Those areas can be found by the method explained in Article 11A.

The *mean forward pressure*, the *mean back pressure*, and the *mean effective pressure*, are found by dividing those three areas respectively by the volume sA , which is represented by \overline{OL} .

Those mean pressures, however, can be found by a direct process, without first-measuring the areas, viz. :—

Divide the length of the diagram \overline{OL} into any convenient number, n , of equal parts (the usual number is *ten*), and measure the ordinates at the two ends and the $n - 1$ points of division; so that ordinates are measured from $n + 1$ equi-distant points in OL .

Let p_0 be the first, p_n the last, and $p_1, p_2, \&c.$, the intermediate ordinates of the upper curve CDE ; let p'_0 be the first, p'_n the last, and $p'_1, p'_2, \&c.$, the intermediate ordinates of the lower curve EGB ; let p_m denote the mean forward pressure, p'_m the mean back pressure, and $p_m - p'_m$ the mean effective pressure. Then

$$\left. \begin{aligned} p_m &= \frac{1}{n} \left(\frac{p_0 + p_n}{2} + p_1 + p_2 + \&c. \right); \\ p'_m &= \frac{1}{n} \left(\frac{p'_0 + p'_n}{2} + p'_1 + p'_2 + \&c. \right); \\ p_m - p'_m &= \frac{1}{n} \left(\frac{p_0 + p_n}{2} + p_1 + p_2 + \&c. \dots - \frac{p'_0 + p'_n}{2} - p'_1 - p'_2 - \&c. \right). \end{aligned} \right\} (1.)$$

It is obvious that the mean effective pressure may be computed at once irrespectively of the forward and back pressures, and of the true zero line, simply by measuring a series of equi-distant *breadths* of the diagram perpendicular to A A, such as \overline{GK} ; the mean of which breadths represents the mean effective pressure. That is, let b_0 be the first, b_n the last, and $b_1, b_2, \&c.$, the intermediate breadths; then

$$p_m - p'_m = \frac{1}{n} \left(\frac{b_0 + b_n}{2} + b_1 + b_2 + \&c. \right) \dots\dots\dots(2.)$$

The effective energy exerted by the steam on the piston during each double stroke is the product of the mean effective pressure, the area of the piston, and the length of stroke, or

$$(p_m - p'_m) A s ; \dots\dots\dots(3.)$$

and if N be the number of double strokes in a minute, the *indicated power in foot-pounds per minute* is

$$(p_m - p'_m) A N s ; \dots\dots\dots(4.)$$

from which the *indicated horse-power* is found by dividing by 33,000.

In a **Double Acting Engine** the steam acts alternately on either side of the piston; and to measure the power accurately, two indicators should be used at the same time, communicating respectively with the two ends of the cylinder. Thus a pair of diagrams will be obtained, one representing the action of the steam on each face of the piston. The mean effective pressure is to be found as above for each diagram separately, and then, if the areas of the two faces of the piston are sensibly equal, *the mean of those two results* is to be taken as the *general mean effective pressure*; which being multiplied by the area of the piston, the length of stroke, and *twice* the number of double strokes or revolutions in a minute, gives the indicated power per minute; that is to say, if p'' denotes the general mean effective pressure, the indicated power per minute is

$$p'' A \cdot 2 N s \dots\dots\dots(5.)$$

If the two faces of the piston are sensibly of unequal areas (as in "trunk engines"), the indicated power is to be computed separately for each face, and the results added together.

If there are two or more cylinders, the quantities of power indicated by their respective diagrams are to be added together.

The following is an example from a double cylinder, double acting engine:—

BREADTHS OF DIAGRAMS, MEASURED BY A SCALE REPRESENTING POUNDS ON THE SQUARE INCH.

$n = 10.$

	FIRST CYLINDER.		SECOND CYLINDER.	
	TOP.	BOTTOM.	TOP.	BOTTOM.
b_0	27	36	16.0	12.4
b_{10}	13	12	2.0	3.8
Sum,	40	48	18.0	16.2
Half sum,	20	24	9.0	8.1
b_1	83	97	10.5	10.8
b_2	91	96	8.5	9.0
b_3	91	84	7.5	8.0
b_4	64	64	7.0	7.1
b_5	57	57	6.6	6.7
b_6	53	46	6.2	6.0
b_7	42	40	6.0	5.6
b_8	35	32	5.1	5.4
b_9	22	22	4.5	5.0
Sum,	558	562	70.9	71.7
Sum $\div 10 =$ mean eff. pres.	55.8	56.2	7.09	7.17
Mean of top and bottom, \times Area of piston, sq. ins.,	56.0	345	7.13	1380
Mean effort, in lbs., \times Stroke, in feet, $2\frac{1}{2}$ \times revolutions per minute, $52\frac{1}{2} \times 2 =$	19320	262.5	9839.4	262.5
Indicated power, in ft.- lbs. per minute, }	5071500		2582842.5	
Total indic. power, in ft.-lbs. per min.,	7654342.5			
$\div 33000 =$ indicated horse-power,	232			

The *inertia* of the moving parts of the indicator, combined with the elasticity of the spring, cause oscillations of its piston above and below the curve which would accurately represent the pressures; but the errors which those oscillations produce in the indication of the pressures at particular instants, being alternately upward and downward, neutralize each other, and do not in the least affect the indicated power, nor the mean effective pressure.

The *friction* of the moving parts of the indicator tends on the whole to make the indicated power and indicated mean effective pressure less than the truth, but to what extent is uncertain.

Every indicator should have the accuracy of the graduation of its scale of pressures frequently tested by comparison with a standard pressure gauge.

The conclusions to be drawn from the figures of indicator diagrams will be treated of in the part of this treatise which relates specially to the steam engine.

44. Indicator—Other Applications.—The indicator may obviously be used for measuring the energy exerted by any fluid, whether liquid or gaseous, in driving a piston; or the work performed by a pump, in lifting, propelling, or compressing any fluid.

SECTION 5.—*Of Brakes.*

45. Brakes Defined and Classed.—The contrivances here comprehended under the general title of *Brakes* are those by means of which friction, whether exercised amongst solid or fluid particles, is purposely opposed to the motion of a machine, in order either to stop it, to retard it, or to employ superfluous energy during uniform motion. The use of a brake involves waste of energy, which is in itself an evil, and is not to be incurred unless it is necessary to convenience or safety.

Brakes may be classed as follows:—

I. *Block brakes*, in which one solid body is simply pressed against another, on which it rubs.

II. *Flexible brakes*, which embrace the periphery of a drum or pulley (as in Prony's dynamometer, Article 39).

III. *Pump brakes*, in which the resistance employed is the friction amongst the particles of a fluid forced through a narrow passage.

IV. *Fan brakes*, in which the resistance employed is that of a fluid to a fan rotating in it.

46. Action of Brakes in General.—The work disposed of by a brake in a given time is the product of the resistance which it produces into the distance through which that resistance is overcome in a given time.

To *stop* a machine, the brake must employ work to the amount of the whole actual energy of the machine, as already stated in Article 34. To *retard* a machine, the brake must employ work to an amount equal to the difference between the actual energies of the machine at the greater and less velocities respectively.

To *dispose of surplus energy*, the brake must employ work equal to that energy; that is, the resistance caused by the brake must balance the surplus effort to which the surplus energy is due; so that if n is the ratio which the velocity of rubbing of the brake bears to the velocity of the driving point, P the *surplus effort* at the driving point, and R the resistance of the brake, we ought to have—

$$R = \frac{P}{n} \dots \dots \dots (1.)$$

It is obviously better, when practicable, to store surplus energy, or to prevent its exertion, than to dispose of it by means of a brake.

When the action of a brake composed of solid material is continuous, a stream of water must be supplied to the rubbing surfaces, to abstract the heat that is produced by the friction, according to the law stated in Article 13.

47. Block Brakes.—When the motion of a machine is to be controlled by pressing a block of solid material against the rim of a rotating drum, it is advisable, inasmuch as it is easier to renew the rubbing surface of the block than that of the drum, that the drum should be of the harder and the block of the softer material—the drum, for example, being of iron and the block of wood. The best kinds of wood for this purpose are those which have considerable strength to resist crushing, such as elm, oak, and beech. The wood forms a facing to a frame of iron, and can be renewed when worn.

When the brake is pressed against the rotating drum, the direction of the pressure between them is obliquely opposed to the motion of the drum so as to make an angle with the radius of the drum equal to the *angle of repose* of the rubbing surfaces (denoted by ϕ ; see Article 13). The component of that oblique pressure in the direction of a tangent to the rim of the drum is the friction (R); the component perpendicular to the rim of the drum is the normal pressure (Q) required in order to produce that friction, and is given by the equation—

$$Q = \frac{R}{f}; \dots \dots \dots (1.)$$

f being the co-efficient of friction, and the proper value of R being determined by the principles stated in Article 46.

It is in general desirable that the brake should be capable of effecting its purpose when pressed against the drum by means of the strength of one man, pulling or pushing a handle with one hand or one foot. As the required normal pressure Q is usually considerably greater than the force which one man can exert, a lever, or screw, or a train of levers, screws, or other convenient mechanism must be interposed between the brake block and the handle, so that when the block is moved towards the drum, the handle shall move at least through a distance as many times greater than the distance by which the block *directly* approaches the drum, as the required normal pressure is greater than the force which the man can exert.

Although a man may be able occasionally to exert with one hand a force of 100 lbs. or 150 lbs. for a short time, it is desirable that, in working a brake, he should not be required to exert a force greater than he can keep up for a considerable time, and exert repeatedly in the course of a day, without fatigue—that is to say, about 20 lbs. or 25 lbs.

48. The **Brakes of Carriages** are usually of the class just described, and are applied either to the wheels themselves or to drums rotating along with the wheels. Their effect is to stop or to retard the rotation of the wheels, and make them slip instead of rolling on the road or railway. The resistance to the motion of a carriage which is caused by its brake may be less but cannot be greater than the friction of the stopped or retarded wheels on the road or rails under the load which rests on those wheels. The distance which a carriage or train of carriages will run on a level line during the action of the brakes before stopping is found by dividing the actual energy of the moving mass before the brakes are applied by the sum of the ordinary resistance and of the additional resistance caused by the brakes; in other words, that distance is as many times greater than the height due to the speed as the weight of the moving mass is greater than the total resistance.

The *skid* or *slipper drag*, being placed under a wheel of a carriage, causes a resistance due to the friction of the skid upon the road or rail under the load that rests on the wheel.

49. **Flexible Brakes** (*A. M.*, 678).—A flexible brake embraces a greater or less arc of the rim of a drum or pulley, whose motion it resists. In some cases it consists of an iron strap, of a radius naturally a little greater than that of the drum; so that when left free, the strap remains out of contact with the drum, and does not resist its motion; but when tension is applied to the ends of the strap, it clasps the drum, and produces the required friction. The rim of the drum may be either of iron or of wood. In other cases, the brake consists of a chain, or jointed series of iron bars, usually

faced with wooden blocks on the side next the drum. When tension is applied to the ends of the chain, the blocks clasp the drum and produce friction; when that tension is removed, the blocks are drawn back from the drum by springs to which they are attached, and the friction ceases.

The following formulæ are exact for perfectly flexible continuous bands, and approximate for elastic straps and for chains of blocks. For their demonstration, the reader is referred to treatises on mechanics.

In fig. 18, let AB be the drum, and C its axis, and let the direction of rotation of the drum be indicated by the arrow. Let T_1 and T_2 represent the tensions at the two ends of the strap, which embraces the rim of the drum throughout the arc AB. The tension T_1 exceeds the tension T_2 by an amount equal to the friction between the strap and drum, R; that is,

$$R = T_1 - T_2$$

Let c denote the ratio which the arc of contact AB bears to the circumference of the drum; f the co-efficient of friction between the strap and drum; then the ratio $T_1 : T_2$ is the number whose common logarithm is $2.7288fc$, or

$$\frac{T_1}{T_2} = 10^{2.7288fc} = N ; \dots\dots\dots(1.)$$

which number having been found, is to be used in the following formulæ for finding the tensions T_1, T_2 , required in order to produce a given resistance R:—

Backward or greatest tension, $T_1 = R \cdot \frac{N}{N-1} ; \dots\dots\dots(2.)$

Forward or least tension, $T_2 = R \cdot \frac{1}{N-1} \dots\dots\dots(3.)$

The following cases occur in practice:—

I. When it is desired to produce a great resistance compared with the force applied to the brake, the backward end of the brake, where the tension is T_1 , is to be fixed to the framework of the machinery, and the forward end moved by means of a lever or other suitable mechanism; when the force to be applied by means of that mechanism will be T_2 , which, by making N sufficiently great, may be made small as compared with R.

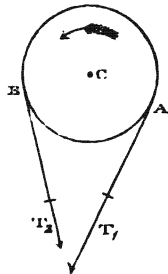

Fig. 18.

II. When it is desired that *the resistance shall always be less than a certain given force*, the forward end of the brake is to be fixed, and the backward end pulled with a force not exceeding the given force. This will be T_1 ; and, as the equation 2 shows, how great soever N may be, R will always be less than T_1 . This is the principle of the brake applied by Professor William Thomson, to apparatus for paying out submarine telegraph cables, with a view to limiting the resistance within the amount which the cable can safely bear.

In any case in which it is desired to give a great value to the ratio N , the flexible brake may be coiled spirally round the drum, so as to make the arc of contact greater than one circumference.

50. **Pump Brakes.**—The resistance of a fluid, forced by a pump through a narrow orifice, may be used to dispose of superfluous energy.

The energy which is expended in forcing a given weight of fluid through an orifice is found by multiplying that weight into the height due to the greatest velocity which its particles acquire in that process, and into a factor greater than unity, which for each kind of orifice is determined experimentally, and whose excess above unity expresses the proportion which the energy expended in overcoming the friction between the fluid and the orifice bears to the energy expended in giving velocity to the fluid.

The following are some of the values of that factor, which will be denoted by $1 + F$:—

For an orifice in a thin plate, $1 + F = 1.054$(1.)

For a straight uniform pipe of the length l , and whose *hydraulic mean depth*, that is, the area divided by the circumference of its cross-section, is m ,

$$1 + F = 1.505 + \frac{fl}{m} \dots\dots\dots(2.)$$

For cylindrical pipes, m is one-fourth of the diameter.

The factor f in the last formula is called the *co-efficient of friction* of the fluid. For *water in iron pipes*, the velocity v being expressed in feet per second, its value, according to Weisbach, is

$$f = 0.0036 + \frac{0.0043}{\sqrt{v}} ; \dots\dots\dots(3.)$$

For *air*, $f = 0.006$ nearly.....(4.)

The greatest velocity of the fluid particles is found by dividing the volume of fluid discharged in a second by the area of the outlet

at its most contracted part. When the outlet is a cylindrical pipe, the sectional area of that pipe may be employed in this calculation; but when it is an orifice in a thin plate, there is a *contracted vein* of the issuing stream after passing the orifice, whose area is on an average about 0.62 of the area of the orifice itself; and that contracted area is to be employed in computing the velocity. Its ratio to the area of the orifice in the plate is called the *co-efficient of contraction*.

The computation of the energy expended in forcing a given quantity of a given fluid in a given time through a given outlet, is expressed symbolically as follows:—

Let V be the volume of fluid forced through, in *cubic feet per second*.

D , the density, or weight of a cubic foot, in *pounds*.

A , the area of the orifice, in *square feet*.

c , the co-efficient of contraction.

v , the velocity of outflow, in *feet per second*.

R , the resistance overcome by the piston of the pump in driving the water, in *pounds*.

u , the velocity of that piston, in *feet per second*.

Then

$$v = \frac{V}{c A}; \dots\dots\dots(5.)$$

and

$$R u = D V (1 + F) \frac{v^2}{2 g}; \dots\dots\dots(6.)$$

the factor $1 + F$ being computed by means of the formulæ 1, 2, 3, 4.

To find the intensity of the pressure (p) within the pump, it is to be observed, as in Article 6, that if A' denotes the area of the piston,

$$V = A' u; R = p A'; \dots\dots\dots(7.)$$

consequently,

$$p = \frac{R}{A'} = D (1 + F) \cdot \frac{v^2}{2 g}; \dots\dots\dots(8.)$$

that is, the *intensity of the pressure is that due to the weight of a vertical column of the fluid, whose height is greater than that due to the velocity of outflow in the ratio $1 + F : 1$.*

To allow for the friction of the piston, about *one-tenth* may in general be added to the result given by equation 6.

The piston and pump have been spoken of as single; and such may be the case when the velocity of the piston is uniform. When a piston, however, is driven by a crank on a shaft rotating at an

uniform speed, its velocity varies; and when a pump brake is to be applied to such a shaft, it is necessary, in order to give a sufficiently near approximation to an uniform velocity of outflow, that there should be at least, either three single acting pumps, driven by three cranks making with each other angles of 120° , or a pair of double acting pumps, driven by a pair of cranks at right angles to each other; and the result will be better if the pumps force the fluid into one common air vessel before it arrives at the resisting orifice.

That orifice may be provided with a valve, by means of which its area can be adjusted, so as to cause any required resistance.

A pump brake of a simple kind is exemplified in the apparatus called the "*cataract*," for regulating the opening of the steam valve in single acting steam engines. It will be more fully described under the head of those engines.*

51. **Fan Brakes.**—A fan, or wheel with vanes, revolving in water, oil, or air, may be used to dispose of surplus energy; and the resistance which it causes may be rendered to a certain extent adjustable at will, by making the vanes so as to be capable of being set at different angles with their direction of motion, or at different distances from their axis.

Fan brakes are applied to various machines, and are usually adjusted so as to produce the requisite resistance by trial. It is, indeed, by trial only that a final and exact adjustment can be effected; but trouble and expense may be saved by making, in the first place, an approximate adaptation of the fan to its purpose by calculation.

The following formulæ are the results of the experiments of Duchemin, and are approved of by Poncelet in his *Mécanique Industrielle*.

For a thin flat vane, whose plane traverses its axis of rotation, let

A denote the area of the vane;

l , the distance of its centre of gravity from the axis of rotation;

s , the distance from the centre of gravity of the entire vane, to the centre of gravity of that half of it which lies nearest the axis of rotation;

v , the velocity of the centre of gravity of the vane ($= a l$, if a is the angular velocity of rotation);

D , the density of the fluid in which it moves;

$R l$, the moment of resistance;

k , a co-efficient, whose value is given by the formula

* Pump brakes have been applied to railway carriages by Mr. Laurence Hill. In 1855, it was proposed by Mr. John Thomson and the author to apply them to the paying-out apparatus of telegraph cables; but that proposal has not yet been practically tried.

$$k = 1.254 + 1.6244 \frac{\sqrt{A}}{l - s}; \dots\dots\dots(1.)$$

then

$$R l = l k D A \cdot \frac{v^2}{2g} \dots\dots\dots(2.)$$

When the vane is oblique to its direction of motion, let i denote the acute angle which its surface makes with that direction; then the result of equation 2 is to be multiplied by

$$\frac{2 \sin^2 i}{1 + \sin^2 i} \dots\dots\dots(3.)$$

It appears that the resistance of a fan with several vanes increases nearly in proportion to the number of vanes, so long as their distances apart are not less at any point than their lengths. Beyond that limit the law is uncertain.

SECTION 6.—*Of Fly Wheels.*

52. **Periodical Fluctuations of Speed** in a machine (*A. M.*, 689) are caused by the alternate excess and deficiency of the energy exerted above the work performed in overcoming resisting forces, which produce an alternate increase and diminution of actual energy, according to the law explained in Article 30.

To determine the greatest fluctuations of speed in a machine moving periodically, take $A B C$, in fig. 19, to represent the motion of the driving point during one period; let the effort P of the prime mover at each instant be represented by the ordinate of the curve $D G E I F$; and let the sum of the resistances, reduced to the driving point as in Article 9, at each instant, be denoted by R , and represented by the ordinate of the curve $D H E K F$, which cuts the former curve at the ordinates $A D$, $B E$, $C F$. Then the integral—

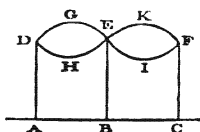

Fig. 19.

$$\int (P - R) ds,$$

being taken for any part of the motion, gives the excess or deficiency of energy, according as it is positive or negative. For the entire period $A B C$ this integral is nothing. For $A B$, it denotes an *excess of energy received*, represented by the area $D G E H$; and for $B C$, an equal *excess of work performed*, represented by the equal area $E K F I$. Let those equal quantities be each represented by

ΔE . Then the actual energy of the machine attains a maximum value at B, and a minimum value at A and C, and ΔE is the difference of those values.

Now let v_0 be the mean velocity, v_1 the greatest velocity, v_2 the least velocity of the driving point, and $\Sigma \cdot n^2 W$ the *reduced inertia* of the machine (see Article 15); then

$$\frac{v_1^2 - v_2^2}{2g} \cdot \Sigma \cdot n^2 W = \Delta E; \dots\dots\dots(1.)$$

which, being divided by the *mean actual energy*—

$$\frac{v_0^2}{2g} \cdot \Sigma \cdot n^2 W = E_0,$$

gives

$$\frac{v_1^2 - v_2^2}{v_0^2} = \frac{\Delta E}{E_0}; \dots\dots\dots(2.)$$

and observing that $v_0 = (v_1 + v_2) \div 2$, we find

$$\frac{v_1 - v_2}{v_0} = \frac{\Delta \cdot E}{2 E_0} = \frac{g \Delta E}{v_0^2 \Sigma \cdot n^2 W}; \dots\dots\dots(3.)$$

a ratio which may be called the *co-efficient of fluctuation of speed* or of *unsteadiness*.

The ratio of the periodical excess and deficiency of energy ΔE to the whole energy exerted in one period or revolution, $\int P ds$, has been determined by General Morin for steam engines under various circumstances, and found to be from $\frac{1}{10}$ to $\frac{1}{4}$ for single cylinder engines. For a pair of engines driving the same shaft, with cranks at right angles to each other, the value of this ratio is about one-fourth, and for three engines with cranks at 120° , one-twelfth of its value for single cylinder engines.

The following table of the ratio $\Delta E \div \int P ds$ for *one revolution* of steam engines of different kinds is extracted and condensed from General Morin's works:—

NON-EXPANSIVE ENGINES.

$\frac{\text{Length of connecting rod}}{\text{Length of crank}}$	=	∞	6	5	4
$\Delta E \div \int P ds$	=	.105	.118	.125	.132

EXPANSIVE CONDENSING ENGINES.

Connecting rod = crank \times 5.

Fraction of stroke at } which steam is cut off }	$\frac{1}{3}$	$\frac{1}{4}$	$\frac{1}{5}$	$\frac{1}{6}$	$\frac{1}{7}$	$\frac{1}{8}$
$\Delta E \div \int P ds =$	·163	·173	·178	·184	·189	·191

EXPANSIVE NON-CONDENSING ENGINES.

Steam cut off at	$\frac{1}{2}$	$\frac{1}{3}$	$\frac{1}{4}$	$\frac{1}{5}$
$\Delta E \div \int P ds =$	·160	·186	·209	·232

For double cylinder expansive engines, the value of the ratio $\Delta E \div \int P ds$ may be taken as equal to that for single cylinder non-expansive engines.

For *tools working at intervals*, such as punching, slotting, and plate-cutting machines, coining presses, &c., ΔE is nearly equal to the whole work performed at each operation.

53. **Fly Wheels** (*A. M.*, 690).—A fly wheel is a wheel with a heavy rim, whose great moment of inertia being comprehended in the reduced moment of inertia of a machine, reduces the co-efficient of fluctuation of speed to a certain fixed amount, being about $\frac{1}{32}$ for ordinary machinery, and $\frac{1}{50}$ or $\frac{1}{60}$ for machinery for fine purposes.

Let $\frac{1}{m}$ be the intended value of the co-efficient of fluctuation of speed, and ΔE , as before, the fluctuation of energy. If this is to be provided for by the moment of inertia I of the fly wheel alone, let a_0 be its mean angular velocity; then equation 3 of Article 52 is equivalent to the following:—

$$\frac{1}{m} = \frac{g \Delta E}{a_0^2 I}; \dots\dots\dots(1.)$$

$$I = \frac{m g \Delta E}{a_0^2}; \dots\dots\dots(2.)$$

the second of which equations gives the requisite moment of inertia of the fly wheel.

The fluctuation of energy may arise either from variations in the effort exerted by the prime mover, or from variations in the resistance, or from both those causes combined. When but one fly

wheel is used, it should be placed in as direct connection as possible with that part of the mechanism where the greatest amount of the fluctuation originates; but when it originates at two or more points, it is best to have a fly wheel in connection with each of those points.

For example, let there be a steam engine which drives a shaft that traverses a workshop, having at intervals upon it pulleys for driving various machine tools. The steam engine should have a fly wheel of its own, as near as practicable to its crank, adapted to that value of ΔE which is due to the fluctuations of the effort applied to the crank-pin above and below the mean value of that effort, and which may be computed by the aid of General Morin's tables, quoted in Article 52; and each machine tool should also have a fly wheel, adapted to a value of ΔE equal to the whole work performed by the tool at one operation.

As the rim of a fly wheel is usually heavy in comparison with the arms, it is often sufficiently accurate for practical purposes to take the moment of inertia as simply equal to the weight of the rim multiplied by the square of the mean between its outside and inside radii, a calculation which may be expressed thus:—

$$I = W r^2; \dots\dots\dots(3.)$$

whence the weight of the rim is given by the formula—

$$W = \frac{m g \Delta E}{a_0^2 r^2} = \frac{m g \Delta E}{v'^2}, \dots\dots\dots(4.)$$

if v' be the velocity of the rim of the fly wheel.

The usual mean radius of the fly wheel in steam engines is from *three to five* times the length of the crank.

The ordinary values of the product $m g$, the unit of time being the second, lie between 1,000 and 2,000 feet.

The fly wheel of a steam engine is often itself a pulley, used to transmit motion to machinery by means of a belt.

SECTION 7.—*Of Regulators and Governors in General (A. M., 693).*

54. The **Regulator** of a prime mover is some piece of apparatus by which the rate at which it receives energy from the source of energy can be varied; such as the sluice or valve which adjusts the size of the orifice for supplying water to a water wheel, the apparatus for varying the surface exposed to the wind by wind-mill sails, the throttle valve which adjusts the opening of the steam pipe of a steam engine, and the damper which controls the supply of air to its furnace. In prime movers whose speed and power have to be varied at will, such as locomotive engines, and winding engines for mines, the regulator is adjusted by hand.

55. **Pendulum Governors.**—In other cases, the regulator is adjusted by means of a self-acting apparatus called a *governor*.

In the most ordinary governors, the principal part of the apparatus consists of a pair or set of equal and similar revolving pendulums (see Article 19) turning about one vertical axis, and driven by a train of mechanism which causes their angular velocity of revolution to bear a fixed ratio to the velocity of the prime mover. The rods of the pendulums place themselves at an angle with the vertical axis, such that the common *height* of the pendulums (\overline{BC} , fig. 7, Article 19) is that corresponding to the number of turns in a second, as given by equation 2 of that Article. Consequently, in a given governor, the cosine of that angle, $\overline{BC} \div \overline{CA}$, varies inversely as the square root of the speed. The regulator must be so adjusted, as to be in the proper position for supplying the proper amount of power when the pendulum rods are at the angle of inclination corresponding to the proper speed of the machine. When the speed deviates above or below that amount, the outward or inward motion of the pendulum rods acts on the regulator so as to open it when the speed is too low, and close it when the speed is too high, either directly through levers and linkwork, as in Watt's steam engine governor, or by throwing into gearing with a revolving bevel wheel, one or other of a pair of bevel wheels which move the regulator opposite ways, as in water wheel governors, or by means of epicyclic gearing moving the regulator in a direction and with a velocity depending on the difference between the velocity of a wheel driven with a speed varying with that of the engine, and a wheel rotating with a constant speed along with the set of pendulums, as in Mr. Siemens's governor.

56. **Balanced Governors.**—Mr. Silver's governor consists of a pair of rotating pendulums, each suspended by its centre of gravity from their common axis, to which a pair of springs tend to place them parallel. When made to rotate, the pendulums diverge from the axis until the *centrifugal couple* of each (Article 22) balances the statical moment of the force exerted by the spring. This governor is useful for marine engines, because of its action being independent of the direction of its axis, and of the force of gravity.

57. **Fan Governors.**—Mr. Hick, Mr. G. H. Smith, and others, have invented governors in which the greater or less resistance of air or of some liquid to the motion of a fan driven by the prime mover, causes the adjustment of the opening of the regulator.

The details of regulators and governors vary so much with the kind of prime mover to which they are applied, that they can be described in connection with special prime movers only.

SECTION 8.—*Summary of the Principles of the Strength of Machines.*

58. **Nature and Division of the Subject.** (*A. M.*, 244).—The present section contains a very brief summary of the application of the principles of the strength of materials to the most simple questions which arise in designing machines. The rules are given without demonstration, in as small compass as possible, in order to save the necessity of referring, in ordinary cases, to more bulky treatises; and are almost all abstracted and abridged from a treatise on *Applied Mechanics*, Part II., Chapter III.

The *load*, or combination of external forces, which is applied to any piece, moving or fixed, in a machine, produces *stress* amongst the particles of that piece, being the combination of forces which they exert in resisting the tendency of the load to disfigure and break the piece, which is accompanied by *strain*, or alteration of the volumes and figures of the whole piece, and of each of its particles. If the load is continually increased, it at length produces either *fracture*, or (if the material is very tough and ductile) such a disfigurement of the piece as is practically equivalent to fracture, by rendering the piece useless.

The **Ultimate Strength** of a body is the load required to produce fracture in some specified way. The **Proof Strength** is the load required to produce the greatest strain of a specific kind consistent with safety; that is, with the retention of the strength of the material unimpaired. A load exceeding the proof strength of the body, although it may not produce instant fracture, produces fracture eventually by long-continued application and frequent repetition.

The **Working Load** on each piece of a machine is made less than the proof strength in a certain ratio determined by practical experience, in order to provide for unforeseen contingencies.

Each solid has as many different kinds of strength as there are different ways in which it can be strained or broken, as shown in the following classification:—

	Strain.	Fracture.
Longitudinal.....	Extension	Tearing.
	Compression.....	Crushing.
Transverse.....	Distortion	Shearing.
	Twisting	Wrenching.
	Bending	Breaking across.

59. (*A. M.*, 247.) **Factors of Safety** are of three kinds, viz:— the ratio in which the *ultimate strength* exceeds the *proof strength*, the ratio in which the *ultimate strength* exceeds the *working load*, and the ratio in which the *proof strength* exceeds the *working load*.

The following table gives examples of the values of those factors which occur in machines :—

	Ult. strength. Proof strength.	Ult. strength. Working load.	Proof strength. Working load.
Steel and wrought iron,.....	2	4 to 6	2 to 3
Wrought iron boilers,.....	2	6	3
Cast iron,.....	2 to 3	6 to 8	2 to 3
Timber; average,.....	3	10	3½
Stone and brick,.....	2	8	4

Almost all the experiments hitherto made on the strength of materials give the *ultimate strength* only. In using those data for the designing of structures and machines, the most convenient process of calculation is to multiply the intended *working load* of a piece by the proper factor, so as to find the *breaking load*, and to make the ultimate strength of the piece equal to that breaking load.

60. The **Proof or Testing** by experiment of the strength of a piece of material is to be conducted in two different ways, according to the object in view.

I. If the piece is to be *afterwards used*, the testing load must be so limited that there shall be no possibility of its impairing the strength of the piece; that is, it must not exceed the proof strength, being from one-third to one-half of the ultimate strength. About double of the working load is in general sufficient. Care should be taken to avoid vibrations and shocks when the testing load approaches near to the proof strength.

II. If the piece is to be *sacrificed* for the sake of ascertaining the strength of the material, the load is to be increased by degrees until the piece breaks, care being taken, especially when the breaking point is approached, to increase the load by small quantities at a time, so as to get a sufficiently precise result.

The *proof strength* requires much more time and trouble for its determination than the ultimate strength. One mode of approximating to the proof strength of a piece is to apply a moderate load and remove it, apply the same load again and remove it, two or three times in succession, observing at each time of application of the load, the *strain* or alteration of figure of the piece when loaded, by stretching, compression, bending, distortion, or twisting, as the case may be. If that alteration does *not sensibly increase* by repeated applications of the same load, the load is within the limit of proof strength. The effects of a greater and a greater load being successively tested in the same way, a load will at length be reached whose successive applications produce increasing disfigurements of the piece; and this load will be greater than the proof

strength, which will lie between the last load and the last load but one in the series of experiments.

It was formerly supposed that the production of a *set*, that is, a disfigurement which continues after the removal of the load, was a test of the proof strength being exceeded; but Mr. Hodgkinson showed that supposition to be erroneous, by proving that in most materials a *set* is produced by almost any load, how small soever.

The strength of bars and beams to resist breaking across, and of axles to resist twisting, can be tested by the application of known weights either directly or through a lever.

To test the tenacity of rods, chains, and ropes, and the resistance of pillars to crushing, more powerful and complex mechanism is required. The apparatus most commonly employed is the hydraulic press. In computing the stress which it produces, no reliance ought to be placed on the load on the safety valve, or on a weight hung to the pump handle, as indicating the intensity of the pressure, which should be ascertained by means of Bourdon's gauge. This remark applies also to the proving of boilers by water pressure.

From experiments made by Messrs. More of Glasgow, and by the Author, it appears, that in experiments on the tension and compression of bars, about *one-tenth* should be *deducted* from the pressure in the hydraulic press for the friction of the press plunger.

The measurement of tension and compression by means of the hydraulic press is but a rough approximation at the best. It may be sufficient for an immediate practical purpose; but for the exact determination of general laws, although the load may be applied at one end of the piece to be tested by means of a hydraulic press, it ought to be resisted and measured at the other end by means of a combination of levers such as that used at Woolwich Dockyard, and described by Mr. Barlow.

61. **Tenacity** (*A. M.*, 265, 268, 269).—The ultimate strength or breaking load of a bar exposed to direct and uniform tension is the product of the area of cross-section of the bar into the *tenacity* of the material. Therefore, let

P denote the breaking load, in pounds;

S the area of section, in square inches;

f the tenacity, in pounds on the square inch; then

$$P = fS; \quad S = \frac{P}{f} \dots \dots \dots (1.)$$

The following are some of the most useful values of the tenacity of materials used in machinery, in lbs. on the square inch:—

METALS.

Bronze or gun metal (copper 8, tin 1),	36,000
Copper, cast,	19,000
" sheet,	30,000
" bolts,	36,000
" wire,	60,000
Iron, cast, various qualities,	13,400 to 29,000
" " average British,	about 16,500
Iron, malleable: boiler plates,	51,000
" " bars, rods, and bolts,	60,000 to 70,000
" " wire,	70,000 to 100,000
Steel,	100,000 to 130,000

TIMBER.

Ash,	17,000
Fir and pine,	12,000 to 14,000
Oak,	10,000 to 19,800
Teak, Indian,	15,000

MISCELLANEOUS.

Hempen cables,	5,600
Iron wire ropes, <i>per square inch of iron</i> ,	90,000
" " <i>per pound weight to the fathom</i> ,	4,480
Leathern belts, <i>working tension</i> ,	285

62. **Cylindrical Boilers and Pipes.**—Let r denote the radius of a thin hollow cylinder, such as the shell of a high pressure boiler ;
 t the thickness of the shell ;
 f the tenacity of the material, in pounds per square inch ;
 p the intensity of the pressure, in pounds per square inch, required to burst the shell. This ought to be taken at **SIX TIMES** the effective working pressure—*effective pressure* meaning the excess of the pressure from within above the pressure from without, which last is usually the atmospheric pressure, of 14.7 lbs. on the square inch or thereabouts.

Then

$$p = \frac{ft}{r} \dots \dots \dots (1.)$$

and the proper proportion of thickness to radius is given by the formula—

$$\frac{t}{r} = \frac{p}{f} \dots \dots \dots (2.)$$

The tenacity of good wrought iron boiler plates has been stated as 51,000 lbs. per square inch. That of a double rivetted joint, *per square inch of the iron left between the rivet holes*, is the same; that of a single rivetted joint somewhat less, as the tension is not uniformly distributed. It is convenient in practice to state the tenacity of rivetted joints in lbs. *per square inch of the entire plate*; and it is so stated in the annexed table, in which the results for rivetted joints are from the experiments of Mr. Fairbairn, and that for a welded joint from an experiment by Mr. Dunn. The joints of plate iron boilers are single rivetted; but from the manner in which the plates break joint, analogous to the bond in masonry, the tenacity of such boilers is considered to approach more nearly to that of a double rivetted joint than that of a single rivetted joint.

Wrought iron plate joints, double rivetted, the diameter of each hole being $\frac{1}{8}$ of the distance from centre to centre of holes,.....	35,700
Wrought iron plate joints, single rivetted,	28,600
Wrought iron boiler shells, with single rivetted joints properly crossed,	34,000
Wrought iron retort, with a welded joint,.....	30,750
Cast iron boilers, cylinders, and pipes (average British iron),.....	16,500

63. **Spherical Shells**, such as the ends of "egg-ended" cylindrical boilers, the tops of steam domes, &c., are *twice as strong* as cylindrical shells of the same radius and thickness.

Suppose a shell of the figure of a segment of a sphere to have a circular flange round its base, through which it is bolted to a flange upon a cylindrical shell, or upon another spherical shell.

Let r denote the radius of the sphere, in inches;

r' , the radius of the circular base of the segmental shell, in inches;

p , the bursting pressure, in lbs. on the square inch;

then the number and dimensions of the bolts by which the flange is held should be such, that the load required to tear them asunder all at once shall be

$$3.1416 r'^2 p; \dots \dots \dots (1.)$$

and the flange itself should require, in order to crush it, the following thrust in the direction of a tangent to it:—

$$\frac{1}{2} p r' \cdot \sqrt{r^2 - r'^2} \dots \dots \dots (2.)$$

If the segment is a complete hemisphere, $r' = r$, and the last expression becomes = 0.

Resistance to a crushing force will be considered farther on.

64. **Thick Hollow Cylinder** (*A. M.*; 273).—The assumption that the tension in a hollow cylinder is uniformly distributed throughout the thickness of the shell is approximately true only when the thickness is small as compared with the radius.

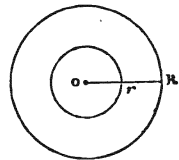

Fig. 20.

Let R represent the external and r the internal radius of a thick hollow cylinder, such as a hydraulic press, the tenacity of whose material is f , and whose bursting pressure is p . Then we must have

$$\frac{R^2 - r^2}{R^2 + r^2} = \frac{p}{f}; \dots\dots\dots(1.)$$

and, consequently,

$$\frac{R}{r} = \sqrt{\left(\frac{f + p}{f - p}\right)}; \dots\dots\dots(2.)$$

by means of which formula, when r , f , and p are given, R may be computed.

65. **Thick Hollow Sphere** (*A. M.*, 275).—In this case, using the same symbols as in the last Article, the following formulæ give the ratios of the bursting pressure to the tenacity, and of the external to the internal radius :—

$$\frac{p}{f} = \frac{2 R^3 - 2 r^3}{R^3 + 2 r^3}; \dots\dots\dots(1.)$$

$$\frac{R}{r} = \sqrt[3]{\left(\frac{2 f + 2 p}{2 f - p}\right)} \dots\dots\dots(2.)$$

66. **Boiler Stays** (*A. M.*, 276).—The sides of locomotive fire-boxes, the ends of cylindrical boilers, and the sides of boilers of irregular figures like those of marine steam engines, are often made of flat plates, which are fitted to resist the pressure from within by being connected together across the water-space or steam-space between them by tie-bars, called stays when long, bolts when short. For example, fig. 21 represents part of the flat side of a locomotive fire-box, and shows the arrangement of the bolts by which it is tied to the flat plate at the other side of the water-space.

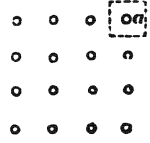

Fig. 21.

Each of these bolts or stays sustains the pressure of the steam against a certain area of the plate to which it is attached. Thus, in fig. 21, the bolt a resists the pressure of the steam on the square area which surrounds it, and whose side is equal to the distance from centre to centre of the bolts.

Let a be the sectional area of a stay; A , that of the portion of flat plate which it holds; p , the bursting pressure, and f the tenacity of the material of the stay. Then

$$a = \frac{p A}{f}$$

Experience has shown, that the plate, if its material is as strong as that of the stay, should have its thickness equal to *half the diameter* of the stay. If the plate be of a weaker material than the stay, its thickness should be proportionally increased.

The flat ends of cylindrical boilers are sometimes stayed to the cylindrical sides by means of triangular plates of iron called "*gussets*." These plates are placed in planes radiating from the axis of the boiler, and have one edge fixed to the flat end, and the other to the cylindrical body. Each gusset sustains the pressure of the steam against a *sector* of the flat circular end. Considering that the resultant tension of a gusset must be concentrated near one edge, it appears advisable that its sectional area should be three or four times that of a stay bar suited for sustaining the pressure on the same area.

The best experimental data respecting the strength of boilers are due to the researches of Mr. Fairbairn, especially those recorded in his work called *Useful Information for Engineers*.

67. **Cylindrical Flues.**—When a thin hollow cylinder, such as an internal boiler flue, is pressed from without, it gives way by *collapsing*, under a pressure whose intensity has been found by Mr. Fairbairn (*Philos. Trans.*, 1858) to vary nearly according to the following laws:—

Inversely as the length;

Inversely as the diameter;

Inversely as a function of the thickness, which is very nearly the power whose index is 2.19; but which for ordinary practical purposes may be treated as sensibly equal to the *square* of the thickness.

The following formula gives approximately the *collapsing pressure* p , in lbs. on the square inch, of a plate iron flue, whose length l , diameter d , and thickness t , are all expressed in *the same units of measure*:—

$$p = 9,672,000 \frac{t^2}{l d} \dots \dots \dots (1.)$$

Let t and d be expressed in inches, and let L be the length in feet; the above formula becomes

$$p = 806,000 \frac{t^2}{L d} \dots \dots \dots (2.)$$

As the resistance of flues to collapse depends very much on their being exactly cylindrical, Mr. Fairbairn recommends that they should be made, not with lap joints, like boiler shells, but with butt joints and covering strips.

Mr. Fairbairn having strengthened tubes by rivetting round them rings of T-iron, or angle iron, at equal distances apart, finds that their strength is that corresponding to the *length from ring to ring*. Safety requires that the collapsing pressure of a flue should be the same with the bursting pressure of the boiler shell in which it is contained; and for other reasons it is desirable that the plates of the flue should be of the same thickness with those of the shell. The thickness of the shell having been adapted to a given bursting pressure by the formula of Article 62, and the same thickness having been assumed for the flue, its collapsing pressure is to be computed by the formulæ 1 or 2 of this Article, putting for l or L the whole length of the boiler. Should the collapsing pressure so calculated prove less than the bursting pressure of the shell, let n be either the ratio

$$\frac{\text{bursting pressure}}{\text{collapsing pressure}},$$

if that is a whole number, or the nearest whole number exceeding that ratio, if it is fractional; then $n - 1$ rings are to be rivetted round the flue, so as to divide its length into n equal divisions; when it will become as nearly as possible of the same strength with the shell.

68. **Elliptical Flues.**—Mr. Fairbairn finds that the collapsing pressure of a flue of an elliptic form of cross-section is found approximately by substituting in the formulæ of the preceding Article, for d , the diameter of the osculating circle at the flattest part of the ellipse; that is, let a be the greater, and b the less *semi-axis* of the ellipse; then we are to make

$$d = \frac{2a^2}{b}.$$

69. **Shearing Force of Keys, Pins, Bolts, Rivets, &c.** (*A. M.*, 280).—In machines, cases occur in which the principal pieces, such as plates, links, or bars, being themselves subjected to a direct pull, are connected with each other at their joints by fastenings, such as rivets, bolts, pins, screws, cotters, or keys, which are under the action of a shearing force. It is in every such case important, that the pieces connected and their fastenings should be of equal strength.

Let f denote the resistance per square inch of the material of the principal pieces to tearing; S , the total sectional area, whether of

one piece or of two or more parallel pieces, which must be torn asunder in order that the structure may be destroyed; f' , the resistance per square inch of the material of the fastenings to shearing; S' , the total sectional area of fastenings at one joint, which must be sheared across in order that the connection may be destroyed; then the principal pieces and their fastenings ought to be so proportioned, that

$$fS = f' S'; \text{ or } \frac{S'}{S} = \frac{f}{f'} \dots \dots \dots (1.)$$

For wrought iron rivetted plates, taking the value of f' as determined by the experiments of Mr. Doyne, we have

$$\frac{f}{f'} = 1 \text{ nearly, and } \therefore S' = S \dots \dots \dots (2.)$$

For wrought iron bars connected by bolts or rivets, we have

$$\frac{f}{f'} = \frac{6}{5} \text{ nearly, and } \therefore S' = \frac{6}{5} S \dots \dots \dots (3.)$$

The following are the resistances of some materials to shearing, in pounds on the square inch :—

Cast iron,.....	32,500
Wrought iron,.....	50,000
Fir and pine,.....	500 to 800
Oak,.....	2,300

70. **Resistance to Direct Crushing** (*A. M.*, 282-4, 286).—The formulæ of this Article have reference to direct crushing only, and are limited in their application to those cases in which the pillars, blocks, struts, or rods, along which the pressure acts are not so long in proportion to their diameter as to have a sensible tendency to give way by bending sideways. Those cases comprehend—

Stone and brick pillars and blocks of ordinary proportions ;

Pillars, rods, and struts of cast iron, in which the length is not more than five times the diameter, approximately ;

Pillars, rods, and struts of wrought iron, in which the length is not more than ten times the diameter, approximately ;

Pillars, rods, and struts of dry timber, in which the length is not more than about twenty times the diameter.

Let P denote the *crushing load* of the piece ;

S the area of its tranverse section in square inches ;

f the resistance of the material to crushing, in lbs. on the square inch ; then

$$S = \frac{P}{f}.$$

MATERIALS.	Crushing pressure, in lbs. on the square inch.
Brick, red,.....	550 to 1,100
Fire brick,.....	1,700
Granite,.....	5,500 to 11,000
Limestone,.....	4,000 to 4,500
Sandstone,.....	2,200 to 5,500
Rubble masonry,.....	$\frac{1}{15}$ of cut stone.
Cast brass,.....	10,300
Cast iron,.....	82,000 to 145,000
" " average,.....	112,000
Wrought iron,.....	about 36,000 to 40,000
Ash (dry, along the grain),.....	9,000
Oak, elm, " " 	10,000
Fir, pine, " " 	5,400 to 6,200
Teak, Indian, " " 	12,000

The resistance of timber to crushing, while green, is about one-half of its resistance after having been dried.

71. **Resistance of Iron Rods and Pillars to Crushing by Bending** (*A. M.*, 327-335).—Pillars and struts whose lengths exceed their diameters in considerable proportions (as is almost always the case with those of timber and metal), give way, not by direct crushing, but by bending sideways and breaking across—being crushed at one side and torn asunder at the other.

Let P be the crushing load of a long rod or pillar, in lbs. ;
 S the sectional area of material in it, in square inches ;
 l , its length,
 h , its least external diameter, } both in the same units of measure.
 Then, approximately—

$$P = \frac{fS}{1 + a \cdot \frac{l^2}{h^2}} \dots \dots \dots (1.)$$

The following are the values of f and a , as computed by Mr. Gordon from Mr. Hodgkinson's experiments on pillars FIXED AT BOTH ENDS, by having flat capitals and bases:—

	f , lbs. per inch.	a .
Wrought iron,.....	36,000	$\frac{1}{3,000}$
Cast iron,.....	80,000	$\frac{1}{400}$

A pillar or rod **ROUNDED OR JOINTED AT BOTH ENDS** is as flexible as a pillar of the same diameter, fixed at both ends, and of double

the length, and its strength is nearly the same. Hence, for such pillars—

$$P = \frac{fS}{1 + 4a \frac{l^2}{h^2}} \dots \dots \dots (2.)$$

Mr. Hodgkinson found the strength of a pillar, *fixed at one end and rounded at the other* to be a mean between the strengths of two pillars of the same length and diameter, one fixed at both ends, and the other rounded at both ends.

In using the formulæ, the ratio $\frac{l}{h}$ is generally fixed beforehand, to a degree of approximation sufficient for the purposes of the calculation.

CONNECTING RODS of *double acting steam engines* are to be considered as in the condition of pillars rounded at both ends; PISTON RODS, as in the condition of pillars fixed at one end and rounded at the other.

The piston rods of *single acting steam engines* are exposed to tension only.

In wrought iron framework and machinery, the bars which act as struts, in order that they may have sufficient stiffness, are made of various forms in cross-section, well known as "angle iron," "channel iron," "T-iron," "double T-iron," &c. In each of these forms, the line to be considered as represented by h in the formulæ is the diameter in that direction in which the bar is most flexible of a triangle or rectangle circumscribed about its section.

Wrought iron cells are rectangular tubes (generally square) usually composed of four plate iron sides, rivetted to angle iron bars at the corners. The *ultimate resistance* of a single square cell to crushing by the buckling or bending of its sides, when the thickness of the plates is *not less than one-thirtieth of the diameter of the cell*, as determined by Mr. Fairbairn and Mr. Hodgkinson, is

27,000 lbs. per square inch section of iron ;

but when a number of cells exist side by side, their stiffness is increased, and their ultimate resistance to a thrust may be taken at

33,000 to 36,000 lbs. per square inch section of iron.

The latter co-efficients apply also to cylindrical cells.

72. **Strength of Timber Posts, Struts, and Connecting Rods.**—The following formula is given on the authority of Mr. Hodgkinson's experiments, for the *ultimate resistance* of posts of *oak* and *red pine* to crushing by bending :—

$$P = A \frac{h^2}{l^2} S ; \dots\dots\dots (1.)$$

S being the sectional area in square inches, $h:l$ the ratio of the least diameter to the length, and $A = 3,000,000$ lbs. per square inch.

The *factor of safety* for the working load of timber is 10.

For square posts and struts, the formula becomes

$$P = A \frac{h^4}{l^2} \dots\dots\dots (2.)$$

If the strength of a timber post be computed both by this formula and by the formula for direct crushing, viz:—

$$P = f S, \dots\dots\dots (3.)$$

the *lesser* value should be adopted as the true strength.

Timber connecting rods for steam engines, being in the condition of pillars jointed at both ends, are of the same strength with *fixed pillars of double the length*.

73. Resistance to Cross Breaking.—The formulæ of this Article are applicable not only to beams for supporting weights, but to levers, cross-heads, cross-tails, axles, journals, cranks, and all pieces in machinery or framework to which forces are applied tending to break them across.

The tendency of a force to bend or break a beam is called the *moment of flexure*. It is the product of the *magnitude* of the force into its *leverage*—that is, into the perpendicular distance from the line of action of the force to the place where the beam will soonest give way.

When the load is *distributed* over a finite length of the beam, the leverage of its *resultant* is to be taken.

The place where the beam will soonest give way is—

In a beam fixed at one end and free at the other, the boundary between the fixed and free parts ;

In a beam supported at both ends and loaded at any intermediate point, or supported at any intermediate point and loaded at the ends, the intermediate point ;

In a beam supported at both ends, with an uniformly distributed load, the middle of the beam.

The *magnitude* of the load is most conveniently expressed in *pounds*, and the *leverage* in *inches* ; so that the *moment of flexure* may be said to be expressed in *inch-pounds*.

In the following formulæ, W denotes the *total load*, in pounds ; c , in beams fixed at one end and free at the other, the *length of the free part*, in inches ;

c , in beams either loaded or supported at both ends, the *half span*, between the extreme points of load or support and the middle, in inches ;

M , the moment of flexure in inch-pounds.

For beams	{	fixed at one end and loaded at the other,.....	$M = c W \dots\dots(1.)$
		fixed at one end and uni- formly loaded,.....	$M = \frac{c W}{2} \dots\dots(2.)$
		supported at both ends and loaded at an intermediate point, whose distance from the middle of the beam is x ,	$M = \frac{(c^2 - x^2) W}{2 c} \dots\dots(3.)$
		supported at both ends and loaded in the middle,.....	$(x=0); M = \frac{c W}{2} \dots\dots(4.)$
		supported at both ends and uniformly loaded,.....	$M = \frac{c W}{4} \dots\dots(5.)$

If W be the intended *breaking load* of the piece, found by multiplying the working load by a proper factor of safety, M will be the *moment of rupture*, to which the *resistance to rupture* at the place where the tendency to break is greatest must be made equal.

That resistance is given by the formula—

$$M = n f b h^2 \dots\dots\dots(6.)$$

in which

b denotes the extreme breadth of the piece, in inches ;

h its extreme depth, in inches ;

f a factor depending on the material, called the *modulus of rupture*, in pounds on the square inch ;

n a factor depending on the figure of the cross-section.

M having been computed from the breaking load and its leverage, and f and n being known, the *scantling* or transverse dimensions of the beam are to be such that

$$b h^2 = \frac{M}{n f} \dots\dots\dots(7.)$$

It is obvious that the breadth and depth may be varied, and still give the product $b h^2$ the same value ; but there are limits to that variation founded on considerations of stiffness and stability, which make it desirable that in most cases h should not greatly differ from *one-fourteenth* of the span, unless there be special reasons to the contrary.

The following table gives examples of the values of the factor n for some of the more usual forms of cross-section :—

I. Rectangle $b h$ (including square),.....	$\frac{1}{6}$.
II. Ellipse, vertical axis h , horizontal axis b , } (including circle, for which $b = h$),..... }	$\frac{1}{10.2} = 0.0982$.
III. Hollow rectangle, $b h - b' h'$; also I-formed } section, where b' is the sum of the } breadths of the lateral hollows,..... }	$\frac{1}{6} \left(1 - \frac{b' h^3}{b h^3}\right)$.
IV. Hollow square, $h^2 - h'^2$	$\frac{1}{6} \left(1 - \frac{h'^4}{h^4}\right)$.
V. Hollow ellipse,.....	$\frac{1}{10.2} \left(1 - \frac{b' h^3}{b h^3}\right)$.
VI. Hollow circle,.....	$\frac{1}{10.2} \left(1 - \frac{h'^4}{h^4}\right)$.

MODULUS OF RUPTURE, IN LBS. ON THE SQUARE INCH.

Wrought iron, plate beams,	f 42,000
„ „ bars and axles,	54,000
Cast iron,.....	$18,750 + 23,000 \frac{H}{h}$
(where H is the <i>depth of solid metal</i> in the section of the beam, and h the <i>extreme depth</i> .)	
Ash,.....	12,000 to 14,000
Fir, pine,.....	7,000 to 12,300
Larch,	5,000 to 10,000
Oak, British, Russian, and American,.....	10,000 to 13,600
Teak,.....	14,800

The modulus of rupture is *eighteen* times the load required to break a bar, one inch square, supported at two points, one foot apart, by being applied in the middle of the bar.

The section for cast iron beams first proposed by Mr. Hodgkinson, in consequence of his discovery of the fact, that the resistance of cast iron to direct crushing is more than six times its resistance to tearing, consists, as in fig. 22, of a lower flange B, an upper flange A, and a vertical web connecting them. The sectional area of the lower flange, which is subjected to tension, is nearly six

times that of the upper flange, which is subjected to thrust. In order that the beam, when cast, may not be liable to crack from unequal cooling, the vertical web has a thickness at its lower side nearly equal to that of the lower flange, and at its upper side, nearly equal to that of the upper flange.

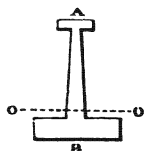

Fig. 22.

The tendency of beams of this class to break by tearing of the lower flange is slightly greater than the tendency to break by crushing of the upper flange; and their modulus of rupture is equal, or nearly equal, to the direct tenacity of the iron of which they are made, being, on an average of different kinds of British iron, 16,500 lbs. per square inch.

The following formula for the moment of rupture of such beams, though not strictly exact, is in general near enough to the truth for practical purposes:—Let B be the sectional area of the lower flange, in square inches; h' the depth in inches from the centre of the upper flange to the centre of the lower flange; then

$$M = 16500 h' B \dots \dots \dots (8.)$$

74. **Resistance to Wrenching.**—For equal values of the modulus of rupture, denoted by f , the strength of a cylindrical axle to resist wrenching is double of its strength to resist breaking across.

Let l denote the length, in inches, of the lever (such as a crank), at the end of which a wrenching or twisting force is applied to an axle; let the working load, in pounds, multiplied by a suitable factor of safety (usually *six*) be denoted by W ; then

$$Wl = M \dots \dots \dots (1.)$$

is the *wrenching moment*, in inch-pounds.

The following are the formulæ which serve to compute the dimensions of axles whose resistances to wrenching shall be equal to a given wrenching moment:—

For a solid axle, let h be its diameter; then

$$M = \frac{f h^3}{5 \cdot 1}; \text{ and } h = \sqrt[3]{\frac{5 \cdot 1 M}{f}} \dots \dots \dots (2.)$$

For a hollow axle, let h_1 be the external and h_0 the internal diameter; then

$$\left. \begin{aligned} M &= \frac{f(h_1^4 - h_0^4)}{5 \cdot 1 h_1} = \frac{f h_1^3}{5 \cdot 1} \cdot \left(1 - \frac{h_0^4}{h_1^4}\right); \\ \text{and } h_1 &= \sqrt[3]{\left\{ \frac{5 \cdot 1 M}{f \left(1 - \frac{h_0^4}{h_1^4}\right)} \right\}}; \end{aligned} \right\} \dots \dots \dots (3.)$$

which last formula serves to compute the diameter of a hollow axle when the ratio $h_0:h_1$ of its internal and external diameter has been fixed.

The values of the modulus of wrenching f are—

- For cast iron,.....about 30,000
- For wrought iron,....., 54,000

and taking six as the factor of safety, if we put the *working moment of torsion* for M in the formulæ instead of the *wrenching moment*, we may put instead of f —

- For cast iron,.....5,000
- For wrought iron,.....9,000

75. Twisting and Bending Combined (*A. M.*, 325).—One of the most important examples of this is shown in fig. 23, which represents a shaft having a crank at one end. At the centre of the crank-pin P is applied the pressure of the connecting rod; and at the centre of the bearing S acts the equal and opposite resistance of that bearing. Representing the common magnitude of those forces by P , they form a couple whose moment is

$$M = P \cdot \overline{SP}.$$

Draw SQ bisecting the angle PSM . On SQ let fall the perpendicular PQ . From Q let fall QM perpendicular to SM .

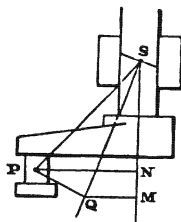

Fig. 23.

Calculate the diameter of the shaft as if to resist the bending action of P applied at M , and it will be strong enough to resist the combined bending and twisting action of P applied at the point marked P .

To express this symbolically, taking the factor of safety at 6, let $W = 6P$. Make the angle $\overline{PSM} = j$; then

$$\overline{SM} = \overline{PS} \cdot \frac{1 + \cos j}{2};$$

and the diameter h of the axles is to be suited to the *moment of breaking across*—

$$M' = W \cdot \overline{SM} = W \cdot \overline{SP} \frac{1 + \cos j}{2} \dots \dots \dots (1.)$$

that is,

$$h = \sqrt[3]{\frac{10 \cdot 2 M'}{f}} \dots \dots \dots (2.)$$

76. **Teeth of Wheels.**—The following is Tredgold's formula for the thickness of the cast iron teeth of wheels, which are to transmit the *working pressure* P.

Let that pressure be expressed in pounds, and the thickness *h* of each tooth in inches; then

$$h = \sqrt{\frac{P}{1500}}$$

SECTION 9.—*Prime Movers Classed.*

77. Prime movers are classed according to the forms in which the energy that drives them is first obtained. These are—

I. *Muscular Power*, applied by men to machines and implements of very various kinds,—and by beasts, chiefly to overcoming resistance by traction and to carrying of burdens.

II. *The Weight and Motion of Fluids*, acting in water pressure engines, water wheels, and other hydraulic engines, and in wind-mills.

III. *Heat*, obtained by means of chemical combination, and applied to the producing of changes in the volume and pressure of fluids, so as to drive engines, of which the *steam engine* is the chief.

IV. *Electricity*, obtained originally by means of chemical combination, and applied to the production and alteration of magnetic force, so as to drive certain engines.

The division of the remainder of this work is founded on the above classification.

PART I.

OF MUSCULAR POWER.

CHAPTER I.

GENERAL PRINCIPLES.

78. *Nature of the Subject.*—Although it has been shown, in a paper by Dr. Joule and the late Dr. Scoresby (*Phil. Mag.*, 1846), that animals acting as prime movers have a higher efficiency than any inorganic machines, still the present state of our knowledge is insufficient to enable us to frame a complete theory of their efficiency. We cannot determine with precision the whole amount of energy which a given animal develops in a given time, so as to compare that amount with the energy which can be rendered effective in the same time in overcoming mechanical resistance. All that we can do is to ascertain by experiment and observation the quantities of *effective energy* exerted by different animals working under different circumstances, and to compare those quantities with each other.

In the present chapter will be stated some principles which hold respecting the muscular power both of men and of beasts. The power of men will be considered specially in the second chapter, and that of beasts in the third.

79. The *Daily Work* of an animal is the product of three quantities—the *resistance* overcome, the *velocity* with which it is overcome, and the number of *units of time per day* during which work is continued. It is known that the amount of the daily work depends on various circumstances, of which the principal are—

- (1.) The species and race.
- (2.) The health, strength, activity, and disposition of the individual.
- (3.) The abundance and quality of food and air, the climate, and other external circumstances affecting those mentioned under head 2.
- (4.) The load, or resistance overcome.
- (5.) The velocity.

(6.) The fraction of the day employed in working.

(7.) The nature of the machine or implement used in performing the work. This cause affects men more especially, owing to the variety and complexity of the machines on which they can exert their muscular power. Beasts are made to work almost exclusively in two ways—by traction and by carrying of burdens; so that little variation in the amount of their mechanical work arises from the circumstances under the present head.

(8.) The practice and training of the individual. This applies principally to men, and in a less degree to beasts.

80. **Influence of Load, Velocity, and Time of Working on Daily Work.**—It is known that for each individual animal there is a certain set of values of the three factors of the daily work which makes their product a maximum, and is therefore the best for economy of power, and that any departure from that set of values diminishes the daily work. Various attempts have been made to represent the law of that diminution by an equation, but they have succeeded imperfectly. The equation which agrees on the whole best with observation is that of Maschek, which is as follows:—Let R_1, V_1, T_1 , represent respectively the resistance, velocity, and daily time of working which give the greatest daily work, and R, V, T , any other resistance, velocity, and daily time of working; then

$$\frac{R}{R_1} + \frac{V}{V_1} + \frac{T}{T_1} = 3 \dots \dots \dots (1.)$$

According to this equation, the maximum daily work $R_1 V_1 T_1$ is realized under the following circumstances:—

R_1 is one-third of the resistance which the man or beast can overcome for an instant and no more.

V_1 is one-third of the velocity which can be maintained without resistance for an instant.

T_1 is one-third of a day. This last principle is generally admitted to be true; the others are doubtful.

The above formula agrees approximately with experiment for circumstances not greatly deviating from those in which the daily work is a maximum.

81. **Influence of Other Circumstances.**—The circumstances numbered 4, 5, and 6 in Article 79 have been considered first, because for them alone has anything approaching to a mathematical principle been ascertained. The effect of the circumstance 7 will be considered in the ensuing chapters. The influence of the other circumstances, 1, 2, 3, and 8, involves questions of natural history and physiology rather than of mechanics. With respect to the circumstance 3, it may be stated, that other things being alike,

the individual that can beneficially breathe most air and digest most food, can also perform most muscular work; and inasmuch as the capacity for the beneficial digestion of food depends in a great measure on the capacity for the beneficial breathing of air, the volume, strength, and soundness of the lungs, and the abundance and purity of the air supplied to them, are of primary importance to muscular power.

It is well known that, by a reciprocal action, muscular exertion increases the powers of respiration and digestion.

82. In the **Transport of Loads**, cases sometimes occur in which it is impossible exactly to determine the resistance overcome by an animal; and it is consequently impossible to calculate the absolute value of the work performed. But a quantity can be computed in each such case which bears some unknown proportion to the work performed, viz:—*the product of the load into the horizontal distance over which it is conveyed.* That product is called “*transport,*” and examples of its values will be given in the sequel.

CHAPTER II.

POWER OF MEN.

83. **Tables of the Performance of Men.**—The results in the following tables are given on the authority of Coulomb, Navier, and Poncelet, with the exception of those marked 16, which are from experiments by Lieutenant David Rankine.

I. WORK OF A MAN AGAINST KNOWN RESISTANCES.

KIND OF EXERTION.	R lbs.	V ft. p. sec.	$\frac{T''}{3600}$ (hours p. day.)	R V ft.-lbs. per sec.	R V T ft.-lbs. p. day.
1. Raising his own weight up stair or ladder,	143	0.5	8	72.5	2,088,000
2. Hauling up weights with rope, and lowering the rope unloaded,	40	0.75	6	30	648,000
3. Lifting weights by hand, ...	44	0.55	6	24.2	522,720
4. Carrying weights up stairs, and returning unloaded,	143	0.13	6	18.5	399,600
5. Shovelling up earth to a height of 5 ft. 3 in.,	6	1.3	10	7.8	280,800
6. Wheeling earth in barrow up slope of 1 in 12, $\frac{1}{2}$ horiz. veloc. 0.9 ft. per sec., and returning unloaded,	132	0.075	10	9.9	356,400
7. Pushing or pulling horizontally (capstan or oar),	26.5	2.0	8	53	1,526,400
8. Turning a crank or winch, ...	12.5	5.0	?	62.5	...
	18.0	2.5	8	45	1,296,000
	20.0	14.4	2 mins.	288	...
9. Working pump,	13.2	2.5	10	33	1,188,000
10. Hammering,	15	?	8?	?	480,000

Explanation.—R, resistance; V, *effective velocity* = distance through which R is overcome \div total time occupied, including the time of moving unloaded, if any; T'', time of working, in seconds per day; $\frac{T''}{3600}$, same time, in hours per day; R V, effective power, in foot-pounds per second; R V T, daily work.

II. PERFORMANCE OF A MAN IN TRANSPORTING LOADS HORIZONTALLY.

KIND OF EXERTION.	L lbs.	V ft. p. sec.	$\frac{T}{3600}$ (hours p. day.)	L V lbs. conveyed 1 foot.	L V T lbs. conveyed 1 foot.
11. Walking unloaded, transport of own weight,.....	140	5	10	700	25,200,000
12. Wheeling load L in 2-wld. barrow, return. unloaded,	224	$1\frac{3}{4}$	10	873	18,428,000
13. Ditto in 1-wh. barrow, ditto,	132	$1\frac{3}{4}$	10	220	7,920,000
14. Travelling with burden,.....	90	$2\frac{1}{2}$	7	225	5,670,000
15. Carrying burden, returning unloaded,.....	140	$1\frac{3}{4}$	6	233	5,082,800
16. Carrying burden, for 30 seconds only,.....	252	0	...	0	...
	126	11.7	...	1474.2	...
	0	23.1	...	0	...

Explanation.—L, load ; V, *effective velocity*, computed as before ; T, time of working, in seconds per day ; $\frac{T}{3600}$, in hours per day, as before ; L V, *transport per second*, in foot-pounds ; L V T, daily transport.

84. *Work of a Man Raising his Own Weight.*—The average amount of this is given in line 1 of the table in Article 83, and is greater than the work which the man can perform by any other mode of exertion. The most simple method of rendering available this kind of work is that invented by a French officer of engineers, Captain Coignet, and applied to the lifting of barrows of earth from an excavation about forty feet deep. A *hoist* is constructed, consisting of a strong rope passing over a large pulley, and having suspended at each end of it a *cage* or enclosed platform. Each barrow of earth on being brought to the foot of the hoist is placed in the cage which has just descended to the lower level. At the same time a man with an empty barrow steps into the other cage at the upper level, and descending along with it, causes the cage containing the full barrow to rise to the higher level, and the barrow is then removed. The man then leaves the cage in which he has descended, and at once returns to the higher level by mounting a ladder. When he mounts the ladder, he *stores energy* to an amount equal to the product of his weight into the vertical height of ascent, which energy is expended when he descends in one cage and raises the load in the other. A party of men are employed in this operation alone, the barrows being wheeled to and from the hoist by others. There is one man whose sole duty it is to attend

to the machine, and either by hand or by means of a brake to control the motion when it tends to become too rapid.

The velocity of vertical ascent given in the table being the *effective* velocity only, is found by dividing the whole height ascended in a day by the whole number of seconds occupied, whether in ascending or in descending.

85. **Lifting Weights by a Rope.**—The data in line 2 of the tables are obtained from the results of the exertions of men in working a *ringing pile engine*, in which a heavy ram moving vertically between guides is attached to a rope passing over a pulley. The other end of the rope branches out into several smaller ropes, held by a sufficient number of men, in the proportion of about one man for each 40 lb. weight of the ram. The men, pulling all together, lift the ram from three to four feet, and let it drop suddenly on the head of the pile. It is found that they work most effectively when, after every three or four minutes of exertion, they have an interval of rest.

86. **Other Modes of Exertion.**—It is scarcely necessary to state that in none of the lines of the first table except that marked 1 is the weight of the man himself included in any load which he is stated as moving.

In line 6, the resistance $R = 132$ lbs. is the *net weight* of the earth in the barrow, and excludes the weight of the barrow itself. The mean actual velocity going and returning is 1·8 feet per second; but as the *effective* velocity is to be computed from the distance travelled *when loaded* only, it is one-half of 1·8, or 0·9 foot per second; and as the rate of ascent of the slope is 1 in 12, the effective vertical velocity is $0·9 \div 12 = 0·075$ of a foot per second, as set down in the column V. It is to be observed that the work set down in this line is that due to the *vertical raising* of the earth only, and is by no means the whole work performed by the man; the conveying the earth horizontally also involves the overcoming of resistance and performing of work, though to what amount is only known by a rough approximation to be mentioned in the next Article.

Line 7 shows that, next to raising his own weight up a ladder, the most favourable modes of exerting a man's strength are the pushing of a capstan bar and pulling of an oar.

Next in amount of daily work, as shown by line 8, is the turning of a crank or winch—the ordinary mode of driving purchases, cranes, monkey pile engines, and a great variety of other machines.

The result in line 9, relative to working a pump, will also apply to windlasses which are worked by levers in the position of pump handles. It applies, amongst other pumps, to those of hydraulic presses—a kind of machine which, although generally worked by

men, involves hydrodynamic principles, which make it necessary to defer its consideration till Part II. of this work.

In line 10, relative to swinging a 15 lb. hammer, some of the data are wanting, and the result is doubtful.

87. **Transporting Loads.**—In the second table, the only line in which the weight of the man is taken into account is that marked 11, where his own weight is the only load conveyed.

By comparing line 13 in the second table with line 6 in the first, it appears that the exertion of wheeling a load of earth horizontally in a one-wheeled barrow from ten to twelve feet or thereabouts, must be nearly equal to that due to the raising of the same earth one foot vertically in wheeling it up a slope.

CHAPTER III.

POWER OF HORSES AND OTHER BEASTS.

88. **Tables of the Performance of Horses.**—The results in the following table are given on the authority of Navier and Poncelet, except the line marked 1, which is from experiments by Mr. David Rankine and the Author. Line 2 contains the mean of several results of experiments on draught horses, and may be considered the *average* of their ordinary performance under the most favourable circumstances as to time of working and velocity.

I. WORK OF A HORSE AGAINST A KNOWN RESISTANCE.

KIND OF EXERTION.	R	V	$\frac{T}{3600}$	RV	RVT
1. Cantering and trotting, drawing a light railway carriage (thoroughbred),.....	$\left. \begin{array}{l} \text{min. } 22\frac{1}{2} \\ \text{mean } 30\frac{1}{2} \\ \text{max. } 50 \end{array} \right\}$	14 $\frac{1}{2}$	4	447 $\frac{1}{2}$	6,444,000
2. Horse drawing cart or boat, walking (draught horse),	120	3.6	8	432	12,441,600
3. Horse drawing a gin or mill, walking,.....	100	3.0	8	800	8,640,000
4. Ditto, trotting,.....	66	6.5	4 $\frac{1}{2}$	429	8,950,000

Explanation.—R, resistance, in lbs.; V, velocity, in feet per second; $T \div 3600$, hours' work per day; RV, work per second; RVT, work per day.

II. PERFORMANCE OF A HORSE IN TRANSPORTING LOADS HORIZONTALLY.

KIND OF EXERTION.	L	V	$\frac{T}{3600}$	LV	LVT
5. Walking with cart, always loaded,.....	1,500	3.6	10	5,400	194,400,000
6. Trotting ditto,.....	750	7.2	4 $\frac{1}{2}$	5,400	87,480,000
7. Walking with cart, going loaded, returning empty; V = $\frac{1}{2}$ mean velocity,.....	1,500	2.0	10	8,000	108,000,000
8. Carrying burden, walking,...	270	3.6	10	972	84,992,000
9. Ditto, trotting,.....	180	7.2	7	1,296	82,659,200

Explanation.—L, load, in lbs.; V, velocity in feet per second; T ÷ 3600, working hours per day; L V, transport per second; L V T, transport per day.

Table II. has reference to conveyance on common roads only, and those evidently in bad order as respects the resistance to traction upon them.

The average power of a draught horse, as given in line 2, Table I., being 432 foot-pounds per second, is $\frac{432}{550} = 0.785$ of the conventional value assigned by Watt to the ordinary unit of the rate of work of prime movers (Article 3).

89. **Oxen, Mules, Asses.**—Authorities differ considerably as to the power of these animals. The following may be taken as an approximative comparison between them and draught horses:—

Ox.—Load, the same as that of average draught horse; best velocity, and work, $\frac{2}{3}$ of horse.

MULE.—Load, one-half of that of average draught horse; best velocity, the same with horse; work, one-half.

Ass.—Load, one quarter of that of average draught horse; best velocity, the same; work, one quarter.

90. **Horse Gin.**—In this machine, as is shown by line 3, a horse works less advantageously than in drawing a carriage along a straight track. In order that the best possible results may be realized with a horse gin, the diameter of the circular track in which the horse walks should not be less than about forty feet.

91. **Tread Wheels for Horses and Oxen** have been used, each consisting of a plane circular platform, rotating about an axis somewhat inclined to the vertical, and ribbed to prevent the feet of the animal from slipping. The animal walks continually up the slope of the platform at or near one end of the horizontal diameter, and by its weight causes the platform to rotate against a resistance.

PART II.

OF WATER POWER AND WIND POWER.

CHAPTER I.

OF SOURCES OF WATER FOR POWER.

92. **Nature of Sources in General.**—The original source of water power is the solar heat, which evaporates liquid water from the surface of the earth and sea. The vapour, condensing in the upper and colder regions of the atmosphere, falls as rain, and forms streams, whose waters, in descending from a high to a low level, exert energy equal to the product of the weight of water which descends into the height through which it descends. In the natural condition of a stream, the whole of the energy due to the descent of its waters is employed in wearing and carrying away the materials of its bed, and in producing heat by friction; but by proper management, a part of that energy can be made available to overcome the resistance of machines.

The art of collecting and distributing, for useful purposes, the rain-fall of a district,—of planning and making reservoirs for storing part of it in seasons of flood, in order to supply its deficiency in seasons of drought, and of adapting natural lakes to answer the same purposes—the art of preserving and improving the natural channels in which it flows, and of planning and making artificial channels, constitute a great and important branch of civil engineering, and cannot be considered within the limits of the present treatise, whose object, as applied to water power, is to set forth the principles and the mode of action of those engines which render that power available when a convenient source has been obtained; that is to say, a stream, discharging a given quantity of water per second, and having a given vertical descent within a convenient distance. Such a combination of circumstances makes a “MILL SITE” or “FALL.”

93. **Power of a Fall of Water—Efficiency.**—The gross power of a fall of water is the product of the *weight* of water discharged in a given unit of time (such as a second, or a minute), into the *total head*; that is, the difference of vertical elevation of the *upper surface*

of the water at the points where the fall in question begins and ends. To express this in symbols, let

Q be the flow, or volume of water discharged, in cubic feet per second;

D, the weight of a cubic foot of water, in lbs., = 62.4 lbs., nearly;

H, the total head; then

$$D Q H \dots \dots \dots (1.)$$

is the *gross power*, in foot-lbs. per second; which being divided by 550, gives the gross horse-power.

There is in every case a certain *loss of head* arising from the waste of energy in various ways to be afterwards mentioned. That waste can usually be computed in the form of a certain fraction of the whole energy exerted; let k denote that fraction; then the *effective power*, in foot-lbs. per second, is

$$(1 - k) D Q H; \dots \dots \dots (2.)$$

and the *efficiency* is

$$1 - k; \dots \dots \dots (3.)$$

$k H$ is called the *loss of head*, and $(1 - k) H$ the *effective head*.

94. *Measurement of a Source of Water Power.*—Two things are to be measured about a fall of water, the head H , and the flow Q . The head is measured by the ordinary operation of levelling. The flow is measured by different methods, according to circumstances.

I. In large streams, the flow can in general be only measured directly; that is, by finding the area of cross-section of the stream, measuring by suitable instruments the velocities of the current, at various points in that cross-section; taking the mean of these velocities, and multiplying it by the sectional area. The most convenient instrument for such measurements of velocity is a small light revolving fan, on whose axis there is a screw, which drives a train of wheel work, carrying indexes that record the number of revolutions made in a given time. The whole apparatus is fixed at the end of a pole, so that it can be immersed to different depths in different parts of the channel. The relation between the number of revolutions of the fan per minute, and the corresponding velocity of the current, should be determined experimentally, by moving the instrument with different known velocities through a piece of still water, and noting the revolutions of the fan in a given time.

II. When from the want of the proper instrument, or any other cause, the velocity of the current cannot be measured at various points, the velocity of its swiftest part, which is at the middle of the surface of the stream, may be measured by observing the motions of any convenient body floating down. Let this greatest velocity in

feet per second be denoted by V ; then according to an empirical formula of Prony's, the mean velocity is

$$v = V \cdot \frac{7.71 + V}{10.25 + V} \dots \dots \dots (1.)$$

III. When the stream is so small that it is practicable to make across it a temporary weir, such a weir is to be made, care being taken that it shall be perfectly water tight at every point except the outlet through which the whole flow of the stream is to pass. The site ought to be chosen with a view to the tightness and security of the weir; and the channel of the stream immediately below the weir should be straight, in order that the rapid current rushing from the outlet may not injure the banks.

The outlet should be a *notch* or depression in the upper edge of a vertical board; hence weirs of this class are called *notch boards*. In fig. 24, A represents a front view, and B a vertical section, of a notch board with a rectangular notch.

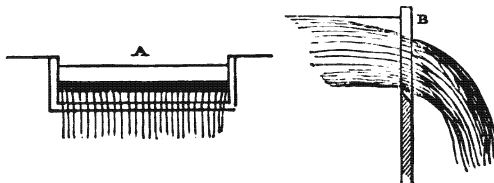

Fig. 24.

The sides and bottom of the notch should be

chamfered to a fine edge, with a vertical surface opposed to the water in the pond above the weir, as shown in the section B; and the better to fulfil this condition, the notch may be edged all round with thin sheet iron. The object of this is, to prevent as far as possible the friction and cohesion between the water and the edge of the notch from interfering with the result.

A vertical scale, divided into feet and decimals, and having its zero at the level of the lower edge of the notch, is to be placed in the pond above the notch board, at some point where the water is either sensibly still, or has a very slow motion only; and the height at which the surface of the water stands on that scale is to be noted from time to time.

Let h be that height, in feet; let b be the breadth of the notch, also in feet. Then the flow, *in cubic feet per second*, is given by the formula

$$Q = \frac{2c}{3} \cdot b h \sqrt{2gh}; \dots \dots \dots (1.)$$

$2g$ being 64.4 , and $\sqrt{2gh}$ the velocity due to the height h ; while c is a fraction called the *co-efficient of contraction*, expressing the

ratio which the sectional area of the most contracted part of the jet or cascade flowing from the notch bears to the area of the rectangle $b h$.

The above formula may also be expressed as follows :—

$$Q = 5.35 c b h^{\frac{3}{2}} \dots\dots\dots *(2.)$$

It is advisable that the breadth of the notch should not be less than *one-fourth* of that of the weir. It may have any convenient breadth from that amount up to the entire width of the weir.

The values of the co-efficient of contraction are—

For a notch of $\frac{1}{4}$ of the width of the weir,.....	.595
For a notch of the whole width of the weir,.....	.667

and for intermediate proportions, the following empirical formula is very nearly correct :—

$$c = 0.57 + \frac{b}{10 B} \dots\dots\dots (3.)$$

B being the breadth of the weir.

When the velocity of the current at the point where the vertical scale stands is too large to be neglected, let v_0 denote that velocity (called the *velocity of approach*), and

$$h_0 = \frac{v_0^2}{2g}$$

the height due to it. Then, according to Mr. Neville's work on Hydraulics, the flow is the difference between that from a still pond due to the height $h + h_0$, and that due to the height h_0 ; so that it is given by the formula

$$Q = 5.35 c b \left\{ (h + h_0)^{\frac{3}{2}} - h_0^{\frac{3}{2}} \right\} \dots\dots\dots (4.)$$

When v_0 cannot be directly measured, it can be computed approximately by taking an approximate value of Q from equation 2, and dividing by the sectional area of the channel at the place where the scale stands.

TABLE OF VALUES OF c AND $5.35 c$.

$\frac{b}{B}$,.....	1.0	0.9	0.8	0.7	0.6	0.5	0.4	0.3	0.25
c ,667	.66	.65	.64	.63	.62	.61	.60	.595
$5.35 c$, 3.57	3.57	3.53	3.48	3.42	3.37	3.32	3.26	3.21	3.18

* $h^{\frac{3}{2}}$ is easily computed, as follows, by the aid of an ordinary table of squares and cubes :—Look in the column of squares for the nearest square to h ; then opposite, in the column of cubes, will be an approximate value of $h^{\frac{3}{2}}$.

IV. Besides the variations in the co-efficient of contraction already stated, which depend on the proportion between the breadths of the weir and of the notch, there are other variations which have been reduced to no general law, depending on the proportions of the dimensions of the notch to each other.

To avoid this inconvenience, Professor Thomson of Belfast has adopted a form of notch in which the section of the issuing jet is always of a similar figure—that is to say, a triangle with the apex downwards, as in fig. 25.

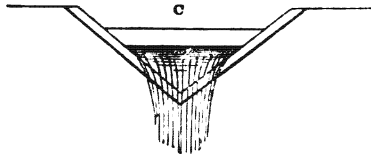

Fig. 25.

Let h be the depth, in feet, of the apex of the notch below the surface of still water in the pond, b the breadth of the notch at the level of the surface of still water; then the area of the triangle bounded by that level and the edges of the notch is $\frac{1}{2} b h$; and theory gives for the discharge in cubic feet per second—

$$Q = \frac{8c}{15} \cdot \frac{bh}{2} \cdot \sqrt{2gh}; \dots\dots\dots(5.)$$

Mr. Thomson's experiments, made for the British Association, give for the co-efficient of contraction—

$$c = .619; \dots\dots\dots(6.)$$

whence

$$Q = .33 \frac{bh}{2} \sqrt{2gh} = 2.645 \frac{bh^{\frac{5}{2}}}{2} \dots\dots\dots(7.)$$

Let $b = 2 a h$, a being a constant ratio; then

$$Q = 2.645 h^{\frac{5}{2}} \dots\dots\dots(8.)$$

V. Instead of an open notch in the top of a weir board, there may be an *orifice*, or a *row of orifices*, wholly beneath the level of the water in the pond. In that case, on account of the variations in the co-efficient of contraction which occur when the orifice has various proportions of length to breadth, and also when the ratio of the *head* of water above the orifice to the breadth of the orifice varies, it is desirable to select such forms and proportions as shall give rise to the smallest variations. For that purpose the orifices should be made either *square* or *circular*; and their size should be such that the height of the surface of still water in the pond shall not be less at any time than three times the diameter of an orifice. These conditions being fulfilled, let A be the area of an

orifice, h the depth of its *centre* below the upper surface of still water; then the flow through it in cubic feet per second is

$$Q = c A \sqrt{2 g h}; \dots\dots\dots(9.)$$

the values of c being—

For round orifices,.....	0·62
For square orifices,.....	0·6

and the values of $c \sqrt{2 g} = 8·02 c$ —

For round orifices,.....	4·98
For square orifices,.....	4·82

No very serious error will be incurred by using these co-efficients, even when the height h falls to *double* the diameter of the orifice.

VI. When the edge of an orifice partly coincides with the border of the channel by which the water is brought to it, so that the water is partially *guided* in a straight course towards the orifice, the case is called one of *partial contraction*; and in computing the discharge, instead of the co-efficient c , there is to be employed—

$$c + 0·09 n; \dots\dots\dots(10.)$$

n being the fraction of the edge of the orifice which coincides with the border of the channel. This formula is Mr. Neville's, and is shown by him to be sensibly correct when n is any fraction not exceeding $\frac{3}{4}$.

CHAPTER II.

OF WATER POWER ENGINES IN GENERAL.

95. **Parts and Appendages of Water Power Engines.**—In every water power engine, or in connection with it, there exist the following parts, or parts equivalent to them :—

I. The **CHANNEL OF SUPPLY**, or **HEAD RACE**, whereby water is brought to the engine, and which extends from the beginning of the fall to the place where the water begins to act on the mechanism. It may be an open conduit, or a close pipe, or a combination of both. Economy of power requires that it should be as large as possible : economy of first cost that it should be as small as possible. The right mean is a matter for the judgment of the engineer in each particular case. This channel usually commences at a head reservoir or pond, and the lower end of it is sometimes of such dimensions as to constitute a second reservoir or *pentstock*. The lower end of the supply channel is of various kinds and forms according to the nature of the engine.

II. The **WASTE CHANNEL**, or **BYE WASH**, whereby any flow of water which is in excess of that required for the stream, and which there is not reservoir room to store, is discharged into the natural drainage channels of the country. This generally commences with a weir or overfall forming part of the boundary of a reservoir, and of such length that the greatest possible flow of waste water can escape over it without rising to a dangerous or inconvenient height.

III. The **REGULATOR**, being the sluice, valve, or other apparatus whereby the flow of water delivered by the head race to the engine is adjusted to the work to be performed. For reasons which will afterwards appear, economy of power requires that the regulator should be as close as possible to the engine, and therefore at the lower end of the channel of supply. The regulator is very frequently controlled by a governor, usually of the revolving pendulum class (Art. 55), of which the details will be exemplified farther on.

IV. The **ENGINE PROPER**, being the machine to which the water transmits energy.

V. The **TAIL RACE**, by which the water is discharged after having driven the engine, and which terminates at the bottom of the fall. The same principles of economy of power and economy of cost apply to this as to the head race.

96. The **Classes of Water Power Engines** are :—

I. **WATER-BUCKET ENGINES**, in which water, poured into suspended buckets, causes them to descend vertically, and so to lift loads or overcome other resistance, as in certain hydraulic hoists.

II. **WATER-PRESSURE ENGINES**, in which water by its pressure drives a piston.

III. **VERTICAL WATER WHEELS**, being wheels rotating in a vertical plane, and driven by the weight and impulse of water. These are the most common of all water power engines.

IV. **HORIZONTAL WATER WHEELS, or TURBINES**, being wheels rotating in a horizontal plane, and driven by the pressure and impulse of water.

V. **RAMS and JET PUMPS**, in which the impulse of one mass of fluid is used to drive another.

97. **Water Power Engines with Artificial Sources.**—The smoothness and steadiness of motion, and some other advantages of water power engines, sometimes occasion the use of machines exactly resembling them in everything, except that the flow and head of water are produced artificially—for example, by pumps worked by hand, as in the common hydraulic press, or by pumps worked by steam, as in some hydraulic hoists and cranes, and in some water wheels for driving fine manufacturing machinery, which are supplied by pumping steam engines.

Such machines are not, properly speaking, *prime movers* for obtaining energy from natural sources, but rather pieces of mechanism for transmitting and conveniently applying energy already obtained by means of other prime movers. The identity of their construction and action, however, with those of true water power engines, renders it advisable to consider them in the present treatise.

98. **Form Assumed by Energy of Fall** (*A. M.*, 619–621).—Let a continuous and uniform stream, whose volume of flow is Q cubic feet per second, and weight of flow DQ lbs. per second, descend from the height or head of H feet to a given point of discharge. That stream is capable of performing work, by the direct ACTION OF ITS WEIGHT in descending, to the amount of

$$D Q H \text{ ft.-lbs. per second.} \dots \dots \dots (1.)$$

Now suppose that from the original elevation H of the upper surface of the stream, down to a point whose elevation above the bottom of the fall is z feet, the descent of the water takes place *without resistance*. It will at the latter point possess the power of performing work *by its weight* to the amount of

$$D Q z \text{ ft.-lbs. per second only; } \dots \dots \dots (2.)$$

but supposing the source to be a reservoir, where the velocity is insensible, the stream will now by its free descent through the height $H - z$, have acquired the velocity—

$$v = \sqrt{2g(H-z)}; \dots\dots\dots(3.)$$

so that, before being brought back to an insensible velocity, it is capable, by **IMPULSE**, of performing the additional work due to its *actual energy*, viz:—

$$\frac{D Q v^2}{2g} = D Q (H-z) \text{ ft.-lbs. per second,} \dots\dots\dots(4.)$$

which being added to the quantity of work in the expression 2, reproduces $D Q H$, the total original power.

Next, let the stream be supposed to descend, in a *close pipe* so large that the velocity of current is still insensible, from the original head H to the less elevation z above the bottom of the fall. Then, as in the last example, equation 2, the stream will at the latter point possess the power of performing $D Q z$ ft.-lbs. per second only of work *by its weight*; but its *pressure* will have become, in lbs. on the square foot—

$$p = D (H-z); \dots\dots\dots(5.)$$

and **BY MEANS OF ITS PRESSURE** the stream will be capable of performing work to the amount of

$$p Q = D Q (H-z) \text{ ft.-lbs. per second,} \dots\dots\dots(6.)$$

which being added to the quantity of work in equation 2, reproduces the total original power $D Q H$, as before.

It appears, then, that if it were possible for a stream to descend absolutely without resistance from the elevation H to any less elevation above the bottom of the fall, and if the pressure at the latter elevation were p lbs. on the square foot, and the velocity v feet per second, the power or energy per second at that elevation, being equal to the original power, would be expressed by

$$Q \left(p + D z + \frac{D v^2}{2g} \right) = D Q H; \dots\dots\dots(7.)$$

or, if the *height due to the pressure* be denoted by $p \div D$ —

$$D Q \left(z + \frac{v^2}{2g} + \frac{p}{D} \right) = D Q H \dots\dots\dots(8.)$$

In this expression,

$$\left. \begin{aligned} D Q \left(z + \frac{p}{D} \right) & \text{ is potential energy, or capacity for performing work by weight and pressure.} \\ D Q \cdot \frac{v^2}{2g} & \text{ actual energy, or capacity for performing work by impulse.} \end{aligned} \right\} (9.)$$

The following equation:—

$$z + \frac{v^2}{2g} + \frac{p}{D} = H, \dots\dots\dots(10.)$$

shows, that at a given elevation z , where the velocity of the stream is v , and the pressure p , there is,

Besides the *actual head* z ,

A *virtual head*, composed of—

The height due to the velocity, $v^2 \div 2g$,

And the height due to the pressure, $p \div D$,

making together a *total head*, which, if the stream has descended without resistance, is equal to the original head H .

Throughout this Article, and the present Part of the treatise, when not otherwise specified, *pressure* is used to mean, the *excess of the pressure of the water above that of the atmosphere*.

99. **Loss of Head** is the form in which the effect of waste of energy in the stream of water during its descent is most conveniently expressed. It may be denoted in the form of a certain fraction of the total head—

$$h = k' H,$$

and then

$$H - h = (1 - k') H \dots\dots\dots(1.)$$

will be the *available head*;

$$D Q (H - h) = (1 - k') D Q H, \dots\dots\dots(2.)$$

the *available power*, or the energy exerted per second by the fall on the engine; and

$$1 - k' = \frac{H - h}{H}, \dots\dots\dots(3.)$$

the *efficiency of the fall*.

If, in the working of the engine, there is a further waste of the fraction k'' of the energy exerted on it, so that the *useful effect* is

$$(1 - k'') (1 - k') D Q H, \dots\dots\dots(4.)$$

then $1 - k''$ is the *efficiency of the mechanism*, and

$$(1 - k'')(1 - k) = 1 - k \text{ (as in Article 93).} \dots \dots \dots (5.)$$

the *resultant efficiency* of the fall and engine combined.

The causes of loss of head are, the velocity of the current in the tail race, and fluid friction.

I. *Current in the tail race.*—If v be the velocity with which the stream is discharged along the tail race, there must be a descent of $v^2 \div 2g$ to produce that velocity, which descent is a loss of head. Hence, as stated in Article 95, the tail race should be as large as is consistent with due economy of first cost.

II. *Friction of passages and channels in general.*—Let A be the sectional area of any passage or channel along which the stream is conveyed, then

$$v = \frac{Q}{A} \dots \dots \dots (6.)$$

is the mean velocity of the current through it.

The loss of head from friction is expressed by the following general formula:—

$$F \cdot \frac{v^2}{2g}; \dots \dots \dots (7.)$$

that is, the product of the height due to the velocity by a *factor of resistance* F , whose value depends mainly on the nature, form, and dimensions of the passage.

The friction takes effect in open channels by producing a declivity of the surface and a loss of actual head; in a close pipe it takes effect by diminishing the pressure, and the virtual head due to it.

A few values of the factor denoted by F have already been given in Article 50, under the head of "Pump Brakes." They will now be repeated in greater detail, and with several additions.

III. *Friction of an orifice in a thin plate:*—

$$F = 0.054 \dots \dots \dots (8.)$$

IV. *Friction of mouthpieces or entrances from reservoirs into pipes.*—Straight cylindrical mouthpiece, perpendicular to side of reservoir:—

$$F = 0.505 \dots \dots \dots (9.)$$

The same mouthpiece making the angle i with a perpendicular to the side of the reservoir:—

$$F = 0.505 + 0.303 \sin i + 0.226 \sin^2 i \dots \dots \dots (10.)$$

For a mouthpiece of the form of the "contracted vein," that is, one of such a form, that if d be its diameter on leaving the reservoir, then at a distance $d \div 2$ from the side of the reservoir it contracts to the diameter $\cdot 7854 d$,—the resistance is insensible, and F nearly = 0.

V. *Friction at sudden enlargements.*—Let A be the sectional area of a channel, in which a sluice, or slide valve, or some such object, produces a sudden contraction to the smaller area a , followed by a sudden enlargement back again to the original area A . Let $v = Q \div A$ be the velocity in the enlarged part of the channel. The *effective* area of the orifice a will be ca , c being a *co-efficient of contraction* whose value may be taken at $\cdot 62 \div \sqrt{1 - \cdot 62 \frac{a^2}{A^2}}$. Let the ratio in which the channel is suddenly enlarged be denoted by

$$m = A \div ca = \sqrt{\left(2 \cdot 62 \frac{A^2}{a^2} - 1 \cdot 62\right)} \dots \dots \dots (11.)$$

Then mv is the velocity in the most contracted part. It appears that all the energy due to the *difference* of the velocities, mv and v , is expended in fluid friction, and consequently that there is a loss of head given by the formula—

$$(m - 1)^2 \cdot \frac{v^2}{2g}; \dots \dots \dots (12.)$$

so that in this case

$$F = (m - 1)^2 \dots \dots \dots (12 A.)$$

VI. *Friction in pipes and conduits.*—Let A be the sectional area of a channel; b its border, that is, the length of that part of its girth which is in contact with the water; l the length of the channel; then, for the friction between the water and the sides of the channel—

$$F = f \cdot \frac{lb}{A}; \dots \dots \dots (13.)$$

in which the co-efficient f has the following values:—

$$\text{For iron pipes,} \dots \dots \dots f = 0 \cdot 0036 + \frac{0 \cdot 0043}{\sqrt{v}} \dots \dots \dots (14.)$$

$$\text{For open conduits,} \dots \dots \dots f = 0 \cdot 00741 + \frac{0 \cdot 000227}{v} \dots \dots \dots (15.)$$

The ratio $\frac{A}{b}$ is called the "*hydraulic mean depth*" of the channel, and for cylindrical and square pipes running full is obviously *one-fourth*

of the diameter ; and the same is its value for a semi-cylindrical open conduit, and for an open conduit whose sides are tangents to a semi-circle of a diameter equal to twice the greatest depth of the conduit.

In an open conduit, the loss of head—

$$h = \frac{f l b}{A} \cdot \frac{v^2}{2g}, \dots \dots \dots (16.)$$

takes place as an actual fall in the surface of the water, producing a declivity at the rate—

$$\frac{h}{l} = \frac{f b}{A} \cdot \frac{v^2}{2g}; \dots \dots \dots (17.)$$

and by the last two formulæ are to be determined the fall and the rate of declivity of open head races and tail races of given dimensions, which are to convey a given flow. In close pipes, the loss of head takes place in the virtual head due to the pressure.

VII. For *bends in circular pipes*, let d be the diameter of the pipe, r the radius of curvature of its centre line at the bend, i the angle through which it is bent, π two right angles ; then, according to Professor Weisbach—

$$F = \frac{i}{\pi} \left\{ 0.131 + 1.847 \left(\frac{d}{2r} \right)^{\frac{1}{2}} \right\} \dots \dots \dots (18.)$$

VIII. For *bends in rectangular pipes* :—

$$F = \frac{i}{\pi} \left\{ 0.124 + 3.104 \left(\frac{d}{2r} \right)^{\frac{1}{2}} \right\} \dots \dots \dots (19.)$$

IX. For *knees*, or sharp turns in pipes, let i be the angle made by the two portions of the pipe at the knee ; then

$$F = 0.946 \sin^2 \frac{i}{2} + 2.05 \sin^4 \frac{i}{2} \dots \dots \dots (20.)$$

X. *Summary of losses of head.*—Let v' be the velocity of the current in the tail race ; F' the factor of resistance for the tail race ; v the velocity in any other part of the course of the water ; F the proper factor of resistance for that part of the course ; then the whole loss of head may be thus expressed :—

$$h = (1 + F') \frac{v'^2}{2g} + \Sigma \cdot F \frac{v^2}{2g} \dots \dots \dots (21.)$$

100. The **Action of the Water on the Engine** has already been distinguished, in Articles 96 and 98, as taking place in three ways :—

- I. By weight.
- II. By pressure.
- III. By impulse.

Now, in all those three modes of acting, the *immediate* effort by which energy is exerted by the water on the engine is a *pressure* between a certain layer of the water and the surface of a moving piece, whether a bucket, a piston, a vane, or another fluid mass which that layer of water drives before it; and the original cause of that effort is the *weight* of the descending stream. The distinction set forth arises in the nature of the process whereby the weight causes the pressure.

I. When the water is said to act *by weight*, portions of it are poured into buckets, and the pressure by which each bucket is driven is the direct effect of, and simply equal to the weight of the water contained in the bucket, and acts vertically downwards, its resultant traversing the centre of gravity of the mass of water in the bucket.

Waste of energy may occur in this case through spilling of the water from the buckets during their descent, or through the remaining of water in the buckets during their ascent. The latter cause of waste of energy ought not to operate to any sensible amount in a well designed machine. The former ought to be reduced to as small an amount as possible.

II. When the water is said to act *by pressure*, the pressure which drives the piston or vane acted upon is not simply the effect of the weight of a portion of water descending along with it, but is the effect of the weight of some more or less distant mass of water transmitted through an intervening mass, and altered to any extent in direction and in the velocity of its action.

III. When the water is said to act *by impulse*, its weight, either directly, or through intervening pressure, is allowed to act freely to such an extent as to produce a jet or current of a certain velocity, whose particles, coming in contact with a float board or vane, or another fluid mass, have that velocity either diminished or taken away; and during that operation they exert a pressure against the float board or vane, or the driven mass of fluid, proportional to the momentum which is taken away from them in each second.

CHAPTER III.

OF WATER BUCKET ENGINES.

101. The **Water Bucket Hoist**, the simplest engine driven directly by the weight of water, is frequently used for raising waggons of coal and other materials to an elevated platform. It consists of—

I. A strong timber frame, supporting at the top one or more large pulleys.

II. A chain passing over the pulleys.

III. A cage for waggons, hung to one end of the chain, and moving between vertical guides. The upper and lower platforms, between which the cage travels, should be provided with strong catches to fix the cage at the higher and lower levels when required.

IV. A water bucket, hung to the other end of the chain, usually moving between vertical guides, and having a valve in the bottom, opening upwards, for discharging the water. This valve may be made self-acting, by making its spindle project downwards, below the bottom of the bucket, so that when the bucket has finished its descent, the spindle may strike upon a floor and lift the valve; but in some cases it is more convenient that the valve should be opened by hand. Rectangular wooden buckets are used; but for lightness and strength, the best material is sheet iron, and the best shape a cylindrical body with a hemispherical bottom.

V. A reservoir and spout for filling the bucket when it is at the higher level. The valve of the spout may, if required, be made self-acting, by causing it to be opened by the rising and shut by the falling of a weighted lever, which is lifted by the edge of the bucket when it reaches the top of its ascent, held up until the bucket is full, and allowed to drop when the bucket begins to descend.

VI. A drain or tail race, to carry away the water discharged from the bucket at the lower level.

VII. A brake, which may be applied to one of the pulleys.

It is advisable, for safety's sake, in most cases, to enclose the course of the cage and that of the bucket in light wooden casings.

The weight of the unloaded cage ought to be somewhat in excess of that of the empty bucket, added to the friction of the machine when unloaded.

The weight of the full bucket ought to be somewhat in excess of that of the loaded cage, added to the friction of the machine when loaded.

The friction is from one-tenth to one-twentieth of the gross load.

In order that the weight of the chain may always be balanced, two pieces of chain with their lower ends lying loose on the ground are hung, the one from the bottom of the cage, and the other from the bottom of the bucket.

The bucket hoist is a bulky and heavy machine, and slow in its operation ; but from its great simplicity, it is easy to make, maintain, and manage, and very durable. Its reservoir may be supplied by a natural source, where one is available ; in other cases, water may be raised to it by a pump worked by a steam engine. The latter combination is a good means of economizing power when heavy loads have to be lifted during short times and at distant intervals. During the intervals when the hoist is standing idle, the steam engine is still storing energy by pumping water into the reservoir ; so the work performed by the hoist during a few hours of each day may be distributed, so far as the exertion of energy by the steam engine is concerned, over the whole twenty-four hours ; and a steam engine, quite inadequate to lift the load to be raised directly, may thus be made to perform the whole work easily by the intervention of the reservoir and hoist as means of storing and restoring energy.

102. **Loss of Head in Bucket Hoists.**—The actual energy with which the water runs from the reservoir into the bucket, and from the bucket into the tail race, is wholly wasted in fluid friction. Therefore in every bucket engine, besides the fall of the tail race, there is a loss of head equal to the height of the surface of the water in the reservoir above the highest level of the surface of the water in the bucket, added to the height of the surface of the water in the bucket when at the bottom of its stroke above the surface of the water in the tail race ; that is, the depth of the bucket at least. In other words, while the *total head* is the elevation of the top water of the reservoir above the outfall of the tail race, the *available head* is the height through which the bucket descends only.

103. **A Double Acting Bucket Engine** has sometimes been used, consisting of a balanced beam, having a pair of equal and similar buckets hung to its two ends, which rise and fall alternately. Each bucket, on arriving at the top of its stroke, is filled with water by a spout from a reservoir, with a valve which is opened and closed by the mechanism. On arriving at the bottom of its stroke, each bucket is emptied through a self-acting valve in its bottom into the tail race. Thus, as in the bucket hoist, the buckets descend full and ascend empty ; and the energy due to the descent of the water in them is employed to work pumps, or otherwise.

The chief advantage of this kind of machine is its adaptation to regions where only rude workmanship can be obtained.

CHAPTER IV.

OF WATER PRESSURE ENGINES.

SECTION 1.—*General Principles.*

104. **Parts of a Water Pressure Engine.**—In a water pressure engine, the several principal parts mentioned in Article 95 as belonging to water power engines in general, take forms suited to that class of engine.

I. The *head race* consists of a *supply pipe* leading from a reservoir to the working cylinder. That pipe, together with the reservoir, constitute what is called the *pressure column*. Besides the regulator, to be presently mentioned, there should be a stop valve or sluice at the upper end of the supply pipe, in or close to the reservoir, so that in the event of an accident occurring to the supply pipe, the current of water may be prevented from entering it. There should also be a grating to prevent the entrance of solid bodies from the reservoir.

All water contains air diffused through it, and most water contains sediment. If there are summits and hollows in the course of the supply pipe (which is often of great length), the air collects at the former and the sediment at the latter. There should be a cock at the upper side of each summit in the course of the pipe, for blowing off air, and at the lower side of each hollow for blowing off sediment.

II. The bye wash has no peculiarities arising from the class of engines.

III. The *regulator* is a valve of one or other of certain kinds to be afterwards mentioned, which are capable of being adjusted to any required extent of opening.

IV. The *engine proper* consists of a *piston* moving in a *cylinder*, together with the *valves* for admitting and discharging the water from the cylinder. The engine is single acting or double acting according as the water acts on one face of the piston only or on each face alternately.

The valves are sometimes worked by hand, in which case the same valve may act as the regulator and the admission valve,—sometimes by mechanism directly driven by the piston of the engine,—and sometimes by a small auxiliary water pressure engine.

The place of the piston is sometimes supplied by a mass of air ; in which case the alterations of volume of that air require to be taken into account.

V. The *tail race* consists of a *discharge pipe*, whose final outlet may be either at, below, or above the level of the cylinder.

105. **Suction Pipe.**—The pressure of the water at the outlet of the discharge pipe is equal to that of the atmosphere, added to that due to the depth at which the water outside the pipe stands above that outlet ; so that when the outlet is below the level of the piston, the pressure within the upper end of the discharge pipe, and in the cylinder while the water is being discharged, may be less than the atmospheric pressure. In this case, the discharge pipe is called a *suction pipe*, and the pressure at its upper end is described by stating *by how much it is below the atmospheric pressure*, either in pounds on the square inch or square foot, or in feet of water, and that deficiency of pressure is conventionally called so many pounds on the inch or foot, or so many feet, "*of vacuum.*" Thus, if the atmospheric pressure is 14·7 lbs. on the square inch, being equivalent to 33·9 feet of head of water, and the absolute pressure in the cylinder during the discharge is two lbs. on the square inch, being equivalent to 4·6 feet of head of water, that pressure is described as 12·7 lbs. on the square inch, or 29·3 feet, *of vacuum.* This mode of expression has been adopted on account of the practical convenience of reckoning pressures from that of the atmosphere as an arbitrary zero.

The absolute pressure against the piston during the discharge is equal to the atmospheric pressure, added to the pressure required to overcome the resistance of the discharge pipe, less the pressure due to the elevation of the upper surface of the water beneath the piston above the bottom of the fall. There never acts in water, at all events in agitated water, negative pressure (that is, tension) to an amount appreciable in practice ; therefore, the height of the upper surface of the water beneath the piston can never be greater than the head due to the atmospheric pressure, added to the head lost in overcoming the friction in the discharge pipe. Should the height of the piston itself above the bottom of the fall be greater than this, the water in the cylinder, on the opening of the discharge valve, will not continue in contact with the piston, but will suddenly drop down to the level given by the principle just stated, leaving between itself and the piston what is commonly called a "vacuum" or "empty space," being in reality a space filled with rare vapour. The height of that space is so much head lost ; its existence tends to make the piston leak, and its periodical emptying and filling is accompanied by shocks or abrupt motions in the water, which tend to injure and wear out the machine ; therefore,

its formation ought to be avoided; and for that purpose the height of the piston above the bottom of the fall ought never to be greater than that due to the least atmospheric pressure and the resistance of the discharge pipe. Now, the water in the discharge pipe is sometimes at rest, and then the resistance is nothing; so that we arrive finally at this rule:—*The greatest height of the piston above the bottom of the fall ought not to exceed the head of water equivalent to the least atmospheric pressure in the locality.*

106. The **Least Atmospheric Pressure** at the level of the sea is about 28 inches of mercury, or 13.75 lbs. on the square inch, or 31.7 feet of water.

The ratio in which the least atmospheric pressure is less than the above amount at a given elevation (z) above the level of the sea, is computed with sufficient exactness for practical purposes by the following formula, in which p_0 is the pressure at the level of the sea, and p_1 the pressure at the elevation of z feet:—

$$\log \frac{p_0}{p_1} = \frac{z}{60346}, \dots \dots \dots (1.)$$

In the absence of tables of logarithms, the following formula, deduced from one proposed by Mr. Babinet, is approximately correct, for heights not exceeding 3,000 feet:—

$$\frac{p_1}{p_0} = \frac{52400 - z}{52400 + z} \dots \dots \dots (2.)$$

When the height exceeds 3,000 feet, divide it into a series of *stages*, each not exceeding 3,000 feet in height; calculate the ratio of the pressures at the top and bottom of each stage, and multiply together the several ratios so found for the ratio of the pressures at the top and bottom of the entire height.

For moderate heights, the following rule is sufficient:—*deduct from the pressure one-hundredth part of itself for each 262 feet of elevation.*

107. **Expansion of Water by Heat—Approximate Formula—Comparison of Units of Pressure.**—It is seldom necessary in calculations connected with water pressure engines to take into account the expansion of water by heat; but in the event of its being at any time requisite to do so, the following formula, although only a rough approximation in a scientific point of view, is sufficiently accurate for the practical purpose in question, and is extremely convenient, from the ease and rapidity with which its results can be computed, especially when a table of reciprocals is at hand:—

Let $D_0 = 62.425$ lbs. to the cubic foot, be the maximum density

of water; D_1 its density at a given temperature of T° on Fahrenheit's scale; then

$$D_1 \text{ nearly} = \frac{2 D_0}{\frac{T^\circ + 461^\circ}{500} + \frac{500}{T^\circ + 461^\circ}}$$

At 212° , this formula gives too great a result by about $\frac{1}{300}$; at lower temperatures its errors are much smaller.

COMPARISON OF HEADS OF WATER IN FEET WITH PRESSURES IN VARIOUS UNITS.

One foot of water at 39°.1 Fahr. =	62.425	lbs. on the square foot.
" "	0.4335	lbs. on the square inch.
" "	0.0295	atmosphere.
" "	0.8826	inch of mercury at 32° .
" "	773.3	{ feet of air at 32° , and 1 atmosphere.
One lb. on the square foot,.....	0.01602	foot of water.
One lb. on the square inch,.....	2.307	feet of water.
One atmosphere of 29.922 inches } of mercury,.....	33.9	" "
One inch of mercury at 32° ,.....	1.133	" "
One foot of air at 32° , and one } atmosphere,.....	0.001293	" "
One foot of average sea water,.....	1.026	foot of pure water.

107 A. **Pressure Gauges — Vacuum Gauges.**— Instruments for indicating the intensity of the pressure of a fluid contained in a close vessel are called "pressure gauges," or "vacuum gauges," according as they show how much that pressure is above or how much it is below that of the atmosphere. Frequently the same instrument answers both those purposes. Of this an example has already been given, in the Indicator (Articles 43, 44), which can be applied to water pressure engines as well as to the steam engine. The following are three examples of other kinds of gauges:—

I. The *mercurial pressure gauge* is the most exact for scientific purposes. It consists, like a siphon barometer, of an inverted siphon, or U-shaped tube, the lower part of which contains mercury, and whose vertical legs have a scale attached alongside of them, divided either into inches and decimals, or divisions corresponding to pounds on the square inch, or other convenient units of pressure. One leg, by means of a brass nozzle, communicates with the vessel within which the fluid is contained; the other is open to the air. The mercury stands lowest in that leg in which the

pressure on its upper surface is most intense; and the difference of level of the mercury in the two legs indicates the difference between the pressure in the vessel, and the atmospheric pressure.

To determine, if required, the absolute pressure within the vessel, the absolute pressure of the atmosphere at the time of observation may be ascertained by means of an ordinary barometer.

Mercurial vacuum gauges are sometimes used, which indicate *directly* the absolute pressure within a vessel, by being constructed exactly like a barometer, having the leg containing the mercurial column that balances the pressure to be measured closed hermetically at the top, with a Torricellian vacuum above the mercury, produced in the usual way, by inverting the tube and boiling the mercury in it.

It is necessary to accurate measurement, that the scales of mercurial pressure gauges should be exactly vertical.

The relations stated in Articles 6 and 107 between inches of mercury and other units of intensity of pressure, have reference to a temperature of 32° Fahrenheit. For any other temperature, T° , on Fahrenheit's scale, let h' be the observed height of a mercurial column, and h the corresponding height *reduced to 32°*; then

$$h = \frac{h'}{1 + 0.0001008 (T^\circ - 32^\circ)} \dots \dots \dots (1.)$$

II. The *air manometer* consists of a long vertical glass tube, closed at the upper end, open at the lower end, containing air, provided with a scale, and immersed, along with a thermometer, in a transparent liquid, such as water or oil, contained in a strong cylinder of glass, which communicates with the vessel in which the pressure is to be ascertained. The scale shows the volume occupied by the air in the tube.

Let v_0 be that volume, at the temperature of 32° Fahrenheit, and mean pressure of the atmosphere p_0 ; let v_1 be the volume of the air, at the temperature T° , and under the absolute pressure to be measured, p_1 ; then

$$p_1 = \frac{(T^\circ + 461^\circ) p_0 v_0}{493^\circ \cdot v_1} \dots \dots \dots (2.)$$

III. *Bourdon's gauge* is the most useful yet known for practical purposes. Its ordinary construction is represented in fig. 26. A is a cock, communicating with the vessel in which the pressure is to be measured. BB is a curved metallic tube, communicating with A at one end, and closed at the other. The cross-section of this tube is of the flattened form represented in fig. 27, and its greatest breadth is in the direction perpendicular to the plane in which the

tube is curved. When the pressure within the tube is greater than the pressure without, the tube becomes less curved; when the

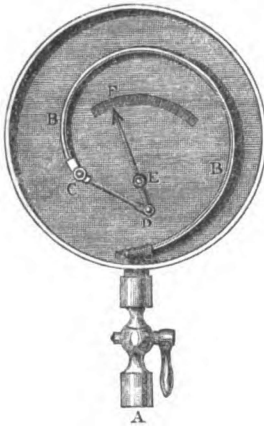

Fig. 26.

pressure without is the greater, it becomes more curved. The motions of the closed end of the tube are communicated either through the link C D, and lever D E, or by means of wheel-work, to the index E F, which points to a graduated arc. The positions of the graduations on the arc are fixed by comparison either with a mercurial gauge for moderate pressures, and an air manometer for very high pressures, or with another Bourdon's gauge known to be correctly graduated.

These gauges can be made of any required degree of sensibility, so that some are suited to measure pressures of less than one atmosphere, and others

to measure pressures of several thousand lbs. on the square inch. Their mechanism is usually contained in a cylindrical brass box, and the dial plate and index are protected by a plate of glass. They can be screwed in every required position upon machines acting by the pressure of fluids.

108. **Fixing Diameter of Supply Pipe.**—In designing a water pressure engine, it is often necessary to fix the diameter of the supply pipe so that it shall deliver a given number of cubic feet of water per second with a loss of head not exceeding a given limit.

Let h denote the prescribed greatest loss of head, in feet. This must correspond to the greatest velocity, and therefore to the greatest flow, through the supply pipe.

Let Q be the number of cubic feet of water required by the engine per second, and Q' the greatest flow per second through the supply pipe. Then if the piston moves for a considerable period with a continuous motion in one direction (as in hydraulic hoists), if the engine is double acting, with an uniformly moving piston, or if it has a pair of single acting cylinders with pistons moving alternately and uniformly,

$$Q' = Q \text{ nearly ;} \dots\dots\dots(1.)$$

If the engine drives a rotating crank shaft,

$$Q' = 1.57 Q \text{ nearly ;} \dots\dots\dots(1 A.)$$



Fig. 27.

When the pressure within the tube is greater than the pressure without, the tube becomes less curved; when the pressure without is the greater, it becomes more curved. The motions of the closed end of the tube are communicated either through the link C D, and lever D E, or by means of wheel-work, to the index E F, which points to a graduated arc. The positions of the graduations on the arc are fixed by comparison either with a mercurial gauge for moderate pressures, and an air manometer for very high pressures, or with another Bourdon's gauge known to be correctly graduated.

if the engine has only one single acting cylinder, and Q is reckoned *per second of the whole time occupied by the piston in descending as well as in rising*, the water stands still in the supply pipe while the piston is descending, and, therefore, in this case,

$$Q' = 2 Q \text{ nearly} \dots \dots \dots (2.)$$

It has already been stated, in Article 99, that the loss of head in a straight pipe is given by the formula

$$h = \frac{f b l}{A} \cdot \frac{v^2}{64 \cdot 4}, \dots \dots \dots (3.)$$

l being the length, b the circumference, A the sectional area, and

$$f = 0 \cdot 0036 + \frac{0 \cdot 0043}{\sqrt{v}} \dots \dots \dots (4.)$$

In a cylindrical pipe of the diameter d , $\frac{A}{b} = \frac{d}{4}$; and, therefore, the equations 3 and 4 may be reduced to the following form:—

$$h = \frac{4 f l}{d} \cdot \frac{v^2}{64 \cdot 4}, \dots \dots \dots (5.)$$

$$4 f = 0 \cdot 0144 + \frac{0 \cdot 0172}{\sqrt{v}} \dots \dots \dots (6.)$$

Now $A = \cdot 7854 d^2$; and, therefore, the velocity in the pipe has the following value:—

$$v = \frac{Q'}{A} = \frac{Q'}{\cdot 7854 d^2}; \dots \dots \dots (7.)$$

and the height due to the velocity,

$$\frac{v^2}{64 \cdot 4} = \frac{Q'^2}{39 \cdot 73 d^4}; \dots \dots \dots (8.)$$

which, being introduced into equation 5, gives

$$h = \frac{4 f l Q'^2}{39 \cdot 73 d^6}; \dots \dots \dots (9.)$$

and consequently

$$d \text{ in feet} = \left(\frac{4 f l Q'^2}{39 \cdot 73 h} \right)^{\frac{1}{6}} \dots \dots \dots (10.)$$

In this formula, the co-efficient of friction f depends on the velocity, which itself depends on the diameter d , being the quantity sought.

It is, therefore, necessary to assume in the first place an approximate value for $4f$. The value commonly assumed is

$$0.0258,$$

which gives, for the *first approximation* to the diameter of the pipe,

$$d = \left(0.00065 \frac{l Q^2}{h}\right)^{\frac{1}{2}} = 0.2304 \left(\frac{l Q^2}{h}\right)^{\frac{1}{2}} \dots\dots(11.)$$

The approximate diameter thus found is to be substituted in equation 7, to find an approximate velocity; from which is to be deduced, by equation 6, a corrected value of $4f$, which being employed in equation 10, gives a *second approximation* to the diameter of the pipe; and this is almost always sufficiently accurate.

To provide for unforeseen causes of increased resistance, such as the deposit of a crust in the pipe, it is customary to add ONE-SIXTH, or thereabouts, to the diameter given by the preceding formulæ.

The diameter, though computed in feet, is commonly reduced to inches when mentioned in the description or specification of the pipe, or written on a drawing.

The pipe is supposed, in this Article, to have what it ought always to have, a mouthpiece at its upper end of the form of the contracted vein, whose resistance is nearly insensible (Article 99).

The formula for the friction of water in pipes, which is that of Professor Weisbach, first published in his work on the *Mechanics of Engineering*, has of late been amply confirmed by the experiments of the same author on velocities of flow up to about forty feet per second (see the periodical *Civil Ingénieur*, new series, vol. v., part 1).

Another method of approximating to the required diameter is as follows:—

Assume a diameter d' , from which, by equation 7, compute the velocity v' corresponding to the required flow Q' . From that velocity, by equation 6, compute the co-efficient $4f$; and thence, by equation 5, the loss of head h' corresponding to the assumed diameter. If this differs from the assigned loss of head h , the required effective diameter d is to be computed by the formula—

$$d = d' \cdot \left(\frac{h'}{h}\right)^{\frac{1}{2}}; \dots\dots\dots(12.)$$

and the actual diameter is to be made one-sixth greater than this effective diameter.

If $\frac{h'}{h}$ is a ratio differing little from unity, then

$$d = d' \cdot \left\{ 1 + \frac{1}{5} \left(\frac{h'}{h} - 1 \right) \right\} \text{ nearly} \dots \dots \dots (12 A.)$$

109. **Effect of the Regulator.**—Let A be the sectional area of the supply pipe; a the area of the opening of the regulator, when partially closed; c the co-efficient of contraction of that opening, as to whose values for different openings, see Article 99. Then by comparing equations 12 A and 13 of Article 99 together, it appears that for equal velocities of flow in the same supply pipe, the resistance is increased by the partial closing of the regulator in the proportion—

$$\begin{aligned} \frac{fbl}{A} + \left(\frac{A}{ca} - 1 \right)^2 : \frac{fbl}{A} :: 1 + \frac{\left(\frac{A}{ca} - 1 \right)^2 \cdot A}{fbl} : 1 \dots (1.) \\ = (\text{for a cylindrical pipe}) 1 + \frac{\left(\frac{A}{ca} - 1 \right)^2 \cdot d}{4fl} : 1. \end{aligned}$$

Let this be expressed, for brevity's sake, by

$$1 + n : 1.$$

This increased resistance may take effect either in increasing the loss of head, or in diminishing the flow, or in both ways at once; but in any case, if Q_0 represents the flow and h_0 the loss of head, with the pipe uninterrupted, and Q_1 the flow and h_1 the loss of head, with the regulator partially closed; then

$$1 : 1 + n :: \frac{h_0}{Q_0^2} : \frac{h_1}{Q_1^2} \dots \dots \dots (2.)$$

The same principle may also be expressed in the following way:—let u_0, u_1 , be the effective mean speed of the piston of the engine corresponding to the discharges Q_0, Q_1 ; then

$$1 : 1 + n :: \frac{h_0}{u_0^2} : \frac{h_1}{u_1^2} \dots \dots \dots (3.)$$

It is better for economy of power that the contraction of the regulator should take effect by diminishing the speed of the engine than by increasing the loss of head; for the volume of water whose passage is prevented by a diminution of speed can be stored in the reservoir for future use; but an increased loss of head gives rise to an irretrievable waste of energy.

110. **Action of the Water on the Piston.**—In a single acting engine, let

H_1 denote the height of the top of the fall above the mean level of the face of the piston, the action of the water on which is under consideration;

h_1 , the loss of head, by the friction of the water in the supply pipe, regulator, valve ports, and cylinder;

Q , the mean flow, in cubic feet per second;

D , the weight of one cubic foot of water;

A , the area of the piston, in square feet;

p_1 , the mean intensity of the effort exerted by the water on the piston during the forward stroke, in lbs. on the square foot;

u , the mean velocity of the piston, in feet per second;

k' , the co-efficient of friction of the piston and mechanism, so that $(1 - k') p_1$ is the intensity of the *useful load*; then

$$p_1 = D (H_1 - h_1); \dots \dots \dots (1.)$$

$$A p_1 = D (H_1 - h_1) A = \text{total effort of the water on the piston}; \dots \dots \dots (2.)$$

$$u = \frac{2 Q}{A}; \dots \dots \dots (3.)$$

energy is exerted by the water on the piston during the forward stroke, at the mean rate of

$$u A p_1 = 2 D Q (H_1 - h_1) \text{ ft.-lb. per second}; \dots \dots (4.)$$

and *useful work performed*, at the rate of

$$2 (1 - k') u A p_1 = 2 (1 - k') D Q (H_1 - h_1) \dots \dots (5.)$$

The value of k' , from experiments of the Messrs. More and the Author, is about $\frac{1}{10}$.

Further, let

H_2 be the mean height of the face of the piston above the bottom of the fall (not exceeding 31.7 feet).—If the bottom of the fall is *above* the mean level of the piston face, H_2 is to be made negative;

h_2 , the loss of head in the discharge pipe and valves;

p_2 , the mean intensity of the effort exerted on the piston during the back stroke; then

$$p_2 = D (H_2 - h_2); \dots \dots \dots (6.)$$

$$A p_2 = D (H_2 - h_2) A \dots \dots \dots (7.)$$

If H_2 is less than h_2 , or negative, these expressions become negative, and represent *resistance* exerted by the water *against* the piston.

During the return stroke energy is exerted on the piston at the mean rate of

$$u A p_2 = 2 D Q (H_2 - h_2) \text{ ft.-lb. per second.....(8.)}$$

If this expression is negative, it represents *work lost* in forcing the water out of the cylinder.

Finally, taking the mean of the expressions 4 and 8, we find for the whole energy exerted by the water on the piston, per second—

$$\begin{aligned} u A \cdot \frac{p_1 + p_2}{2} &= D Q (H_1 + H_2 - h_1 - h_2) \\ &= D Q (H - h); \dots\dots\dots(9.) \end{aligned}$$

$H = H_1 + H_2$ being the total fall, and
 $h = h_1 + h_2$ the total loss of head;
 while the useful work per second is

$$(1 - k^n) D Q (H - h), \dots\dots\dots(10.)$$

and the combined efficiency of the fall and engine—

$$\frac{(1 - k^n) (H - h)}{H} \dots\dots\dots(11.)$$

This varies, in different cases, from about 0.67 to about 0.8.

SECTION 2.—Of Valves.

111. **Valves in General**, considered with reference to the means by which they are moved, may be divided into three principal classes:—Valves, sometimes called *clacks*, which are opened and shut by the pressure of the fluid that traverses their openings, and are usually intended for the purpose of permitting the passage of the fluid in one direction only, and stopping its return;—valves moved by hand;—and valves moved by mechanism. When a piston drives a fluid, as in ordinary pumps, the valves are usually moved by the fluid: when the fluid drives the piston, it is in general necessary that the valves should be moved by hand or by mechanism. In water pressure engines that work occasionally and at irregular intervals, such as hydraulic hoists and cranes, the valves are usually opened and shut by hand; in those which work periodically and continuously, they are moved by mechanism connected with the engine.

Safety valves for permitting a fluid to escape from a vessel when the pressure tends to rise above the limit of safety, belong to the class that are moved by the fluid. Regulating valves are adjusted either by hand, or by means of a governor.

The **SEAT** of a valve is the fixed surface on which it rests, or against which it presses.

The **FACE** of a valve is that part of its surface which comes in contact with the seat.

When a valve occurs *in the course* of a pipe or passage, the valve box or chamber, being that part of the passage in which the valve works, should always be of such a shape as to allow a free passage for the fluid when the valve is open, so that the fluid may pass the valve with as little contraction of the stream as possible; and if necessary for that purpose, the valve chamber may be made of larger diameter than the rest of the passage.

The usual materials for valves and their seats are iron, bronze, brass, hardwood, leather, india rubber, and gutta percha.

When a valve and its seat are both of metal, they should be of the same metal; for when they are of different metals, a galvanic action takes place, which causes one or other of them to be corroded.

In water pressure engines and pumps, the best material for the seats of metal valves is some hard wood, such as elm or lignum vitæ, the fibres being set endways, and constantly wet.

India rubber and gutta percha being dissolved or softened by oils, whether fatty or bituminous, are unsuitable materials for valves to which those fluids have access.

112. The **Bonnet Valve** or **Conical Valve** is a flat or slightly arched circular plate of metal, whose face, being formed by its rim, is sometimes a frustum of a cone, and sometimes a zone of a sphere, the latter figure being the best. Its *seat*, being the rim of the circular orifice which the valve closes, is of the same figure with the face or rim of the valve, and the valve face and its seat are turned and



Fig. 28.

ground to fit each other exactly, so that when the valve is closed no fluid can pass. The thickness of a valve of this form is usually from a fifth to a tenth of its diameter, and the mean inclination of its rim about 45° .

To insure that the valve shall rise and fall vertically and always return to its seat in closing, it is sometimes provided with a *spindle*, as shown in fig. 28, being a slender round rod perpendicular to the valve at its centre, and moving through a ring or cylindrical socket. A knob on the end of the spindle prevents the valve from rising too high. When the valve is to be moved by hand or by mechanism,

the spindle may be continued through a stuffing box, and connected with a handle or a lever, so as to be the means of transmitting motion to the valve.

When the valve seat is at the upper end of a cylindrical passage, as in ordinary safety valves, the place of the spindle is often supplied by means of a *tail*, which will be described in the next Article.

113. The **Common Safety Valve** used for steam boilers as well as for water pressure engines, is a bonnet valve loaded with a weight equal to the greatest excess of the pressure upon each area equal to that of the valve within the vessel on which the valve is fitted, above the pressure of the atmosphere, to which it is safe to subject that vessel during its ordinary use.

Sometimes the valve has a vertical spindle rising from it, moving in guides, and loaded directly with cylindrical weights which rest on a collar that surrounds the spindle.

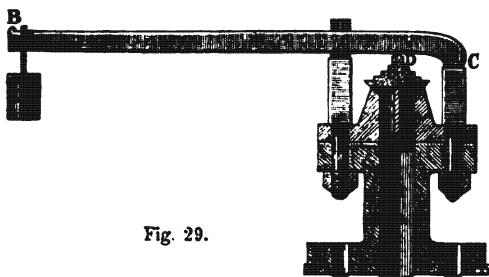

Fig. 29.

Sometimes the load is applied by means of a lever, as in fig. 29, which represents a section of the valve seat and valve, and an elevation of the lever. A is the valve, D a stud or knob in the centre of its upper side, C B a lever jointed to a fixed fulcrum at C, B the weight, which can be shifted to different positions on the lever, so as to vary the load on the valve.

The intensity of the effective pressure p per square inch necessary to open the valve is given as follows:—Let B denote the weight applied to the lever, L that of the lever itself, \overline{GC} the distance of the centre of gravity of the lever from the joint \overline{C} , W the weight of the valve, A its area in square inches; then

$$p = \left\{ \frac{B \cdot \overline{BC} + L \cdot \overline{GC}}{\overline{DC}} + W \right\} \div A.$$

Fig. 30 is an elevation of the valve, showing the *tail* (already referred to in the last Article), by which it is guided so as to move vertically, and to return always to its seat. Fig. 31 is a horizontal section of the tail, which consists of three vertical ribs or "feathers," radiating at angles of 120° . Their outer surfaces or edges are small portions of a vertical cylinder, turned to fit the cylindrical tube on which the valve is placed easily but not too loosely.



Fig. 30.



Fig. 31.

Modifications of the safety valve, specially suited to steam engines, will be described under the head of that class of prime movers.

114. The **Ball Clack** (fig. 32) is a valve of the form of an accurately turned sphere. When of large size, it is in general hollow, in order to reduce its weight. Its face is its entire surface: its seat is a spherical zone, as in the case of some bonnet valves already referred to.

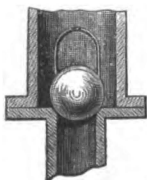

Fig. 32.

As the ball clack fits its seat alike in every position, it needs neither spindle nor tail; but either the chamber in which it works must be of such a shape and size as to insure its always falling into its seat, or the same object must be effected by means of wire guards enclosing it, as shown in the figure. The latter plan is the better,

as it is the more likely to insure that there shall always be a free passage for the fluid round the valve when open.

115. **Divided Conical Valve.**—Bonnet valves of large size, when working under high pressures, often require an inconveniently great amount of work to open them, and shut with such violence as to cause injurious shocks to the machine. To obviate this evil, a valve has sometimes been used, composed of a series of concentric rings. The largest ring may be considered as a bonnet valve, in which there is a circular orifice, forming a seat for a smaller bonnet valve, in which there is a smaller circular orifice, forming a seat for a still smaller bonnet valve, and so on. This arrangement enables a large opening for the passage of water to be formed with a moderate upward motion of each division of the valve; and consequently with a moderate expenditure of work to open it, and a moderate shock when it shuts.

116. The **Double-Beat Valve** (an invention of Messrs. Harvey and West) is the best contrivance yet known for enabling a large passage for a fluid to be opened and shut easily under a high pressure. Fig. 33 represents a section of the valve, with its seats and chamber, and fig. 34 a plan of the valve alone.

The valve shown in the figure is for the purpose of opening and shutting the communication between the pipes A and B.

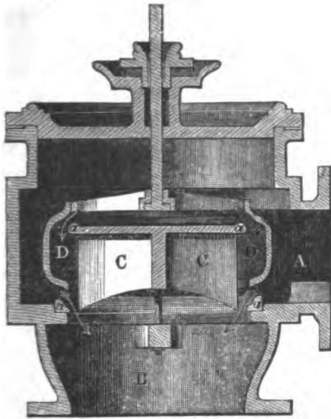

Fig. 33.



Fig. 34.

The pipe B is vertical, and its upper rim carries one of the two valve seats, which are of the form of the frustum of a cone, and each marked *a*.

A frame C, composed of radiating partitions, fixed to and resting on the upper end of the pipe B, carries a fixed circular disc, whose rim forms the other conical valve seat.

The valve D is of the form of a turban, and has two annular conical faces, which, when it is shut, rest at once on and fit equally close to the two seats *a, a*. When the valve is raised, the fluid passes at once through the cylindrical opening between the lower edge of the valve and the upper edge of the pipe B, and through the similar opening between the upper edge of the valve and the rim of the circular disc.

The greatest possible opening of the valve is when its lower edge is midway between the disc and the rim of the pipe B, and is given by the following formula:—

Let

d_1 be the diameter of the pipe B;

d_2 , that of the disc;

h , the clear height from the pipe to the disc, less the thickness of the valve;

A, the greatest area of opening of the valve; then

$$A = 3.1416 \frac{d_1 + d_2}{2} \cdot h ; \dots \dots \dots (1.)$$

and in order that this may be at least equal to the area of the pipe B, viz., $.7854 d_1^2$, we should have

$$h \text{ at least} = \frac{d_1^2}{2(d_1 + d_2)} ; \dots \dots \dots (2.)$$

which, if as is usual, $d_1 = d_2$, gives

$$h \text{ at least} = \frac{d_1}{4} ; \dots \dots \dots (2 A.)$$

but h is in general considerably greater than the limit fixed by this rule.

If the upper and lower seats are of equal diameter, the valve is little affected by any excess of pressure either in A or in B; and a force a little exceeding its own weight is sufficient to open it. It is then called an **EQUILIBRIUM VALVE**.

If the diameter of the upper seat is the less, an excess of pressure in A over B tends to keep it shut, and an excess of pressure in B over A to open it.

If the diameter of the upper seat is the greater, an excess of pressure in A over B tends to open the valve, and an excess of pressure in B over A to keep it shut. This arrangement is seldom used.

In each case, the force arising from difference of intensity of pressure, and tending to open or shut the valve, as the case may be, is nearly equal to that difference multiplied by the difference between the area of the pipe B and that of the circular disc.

The equilibrium valve is the kind of double-beat valve most commonly used in steam engines. In water pressure engines, pumps, and hydraulic apparatus generally, the lower valve seat is generally made a little larger than the upper.

117. **A Flap Valve**, illustrated by fig. 35, is a lid which opens and shuts by turning on a hinge. The hinge may either be a metal joint, or may be provided by the flexibility of the material of the valve itself, when that is leather or india rubber.



Fig. 35.

The face may be of leather, india rubber, or metal; in the last case the face and seat should be carefully scraped to true planes.

In hydraulic machines, the most common material for flap valves is leather, which should, as far as possible, be kept constantly wet. A large leather flap may be stiffened in the middle by a plate of wood or metal.

A pair of flap valves placed hinge to hinge (usually made of one piece of leather fastened down in the middle) constitute a "BUTTERFLY CLACK." The chamber of a flap valve should be of considerably greater diameter than the valve.

118. A **Flap and Grating Valve** consists of a round disc of waterproof canvas or of india rubber, resting on a flat horizontal grating, or on a plate perforated with holes, to which it is fastened down at the centre, being left loose at the edges. To prevent the valve from rising too high, it is usually provided with a guard, which is a thin metal cup formed like a segment of a sphere, grated or perforated like the valve seat, to which it is bolted at the centre, serving also to fasten the valve down at that point. The cup should have a metal shoulder at its base, a little less in depth than the thickness of the flap, to press directly against the seat, so that the tension of the bolt may not be brought to bear on the flap, which would be unable to sustain it. When the valve is raised by a current from below, it applies itself to the bottom of the cup. When the current is reversed, the fluid from above, pressing on the valve through the holes in the cup, drives it down to its seat again.

According to Mr. Bourne, valves of this class, when made of india rubber, may be about six inches in diameter and five-eighths of an inch thick. They are adapted to large pumps by making them sufficiently numerous. They are now much used for the air pumps of steam engines, in which the pressure they have to sustain is less than one atmosphere. It is probable that they are not capable of bearing very high pressures.

119. The **Disc and Pivot Valve, or Throttle Valve**, consists of a thin flat metal plate or disc, which, when shut, fits closely the opening of a pipe or passage, generally circular in section, but sometimes rectangular. The valve turns upon two pivots or journals, placed at the extremities of a diameter traversing its centre of gravity, so that the pressure of the fluid against it is balanced about its axis of rotation, and the valve can be turned into any angular position by a force sufficient to overcome its friction.

When the valve is turned so as to lie edgewise along the passage, the current of fluid passes with very little obstruction: when it is turned transversely, the current is stopped, or nearly stopped. By placing the valve at various angles, various openings can be made. If the valve, when shut, is perpendicular to the axis of the pipe, the opening for any given inclination of the valve to that axis is proportional to the *covered-sine of the inclination*. If the valve is oblique when shut, the opening at a given inclination is proportional to the *difference between the sine of that inclination and the sine of the inclination when shut*.

The *face* of this valve is its rim; its *seat* is that part of the internal surface of the passage which the rim touches when the valve is shut; and those surfaces ought to be made to fit very accurately, without being so tight as to cause any difficulty in opening the valve.

One of the journals of the valve usually passes through a bush or a stuffing box in the pipe, so as to afford the means of communicating motion to the valve from the outside.

It is difficult to make valves of this class perfectly water-tight or steam-tight without too much impeding their motion. They are, therefore, not so well suited for stop valves as for regulating valves, and for the latter purpose they are much used, both in water pressure engines and in steam engines.

Their form will be illustrated in the figures of engines of which they form part.

120. **Slide Valves.**—The *seat* of a slide valve consists of a plane metal surface, very accurately formed, part of which is a rim surrounding the orifice or *port*, which the valve is to close, and from $\frac{1}{4}$ to $\frac{1}{20}$ of the breadth of that orifice, while the remainder extends to a distance from the orifice equal to the diameter of the valve, in order that the valve, when in such a position as to leave the port completely open, shall still have every part of its face in contact with the seat.

The valve is of such dimensions as to cover the port together with that portion of the seat which forms a rim surrounding the port. The face of the valve must be a true plane, so as to slide smoothly on the seat; and in large slide valves consists of a rim surrounding that central part of the valve which directly closes the orifice, and which is more or less concave, to enable it the better to resist the pressure which acts on the back of the valve when it is closed.

Very large slide valves, such as those in the course of the main water pipes of large towns, are strengthened at the back by flanges or ribs.

The valve and its seat are contained within an oblong box or case, large enough to permit the easy motion of the valve within it, and usually forming an enlargement in the course of a pipe. The *valve rod*, by means of which the valve is opened and shut, passes out through a stuffing box; or instead of such a rod, a valve of moderate size often has a nut fixed to it, within which works a screw on the end of an axle, which passes out through a bush, and has shoulders within and without to prevent it from moving longitudinally, and a square on the outer end on which the key fits that is used in turning it.

The total pressure between the face and seat of a slide valve is equal to the total area of the valve, multiplied by the excess of intensity of the pressure behind it above the pressure in front of it.

That total pressure being multiplied by the co-efficient of friction between the face and seat, which may be as much as 0.2 (see Article 13), gives the resistance of the valve to being opened, which is almost always considerable. For the double purpose of enabling that resistance to be overcome by a moderate effort, and of preventing the shocks which would arise from suddenly closing the valve when there is a rapid current passing, it is necessary that the valve should move slowly as compared with the driving point of the apparatus by means of which it is moved. In moderate sized valves, this is usually provided for by causing them to be opened and shut by turning a screw, as already described, or by moving the valve rod by a rack and pinion of suitable dimensions.

Large slide valves are sometimes moved by attaching the valve rod to a piston contained in a cylinder, which has a pair of supply pipes, one for each end, bringing water from the main pipe behind the valve, and a pair of discharge pipes, one for each end, leading to the main pipe in front of the valve. These four pipes are provided with suitable cocks or valves to be opened and shut by hand; and thus is formed a small water pressure engine, by means of which the slide valve can be moved either way when required.

The opening and shutting of a very large slide valve is sometimes facilitated by making it in two divisions—a larger and a smaller. The smaller division is opened first and closed last: the effect of which is, that it alone has to be moved against the resistance arising from the greatest difference of pressure before and behind the valve; and that the larger division has only to be moved against the resistance arising from the pressure corresponding to the *loss of head* caused by the contraction and subsequent enlargement of the stream in passing through the smaller division of the orifice; as to which see Article 99.

Rotating slide valves are sometimes used, in which the valve and its seat are a pair of circular plates, having one or more equal and similar orifices in them. The passage is opened by turning the valve about its centre until its openings are opposite to those of the seat, and shut by turning it so that its openings are opposite solid portions of the seat.

Various forms of slide valve peculiar to the steam engine will be described under the head of that class of prime movers.

121. **A Piston Valve** is a piston moving to and fro in a cylinder,

whose internal surface is the *valve seat*. The *port* is formed by a ring or zone of openings in the cylinder, communicating with a passage which surrounds it; and by moving the piston to either side of these openings, that passage is put in communication with the opposite end of the valve cylinder. Details and particular forms of the piston valve will be illustrated farther on.

122. **Cocks.**—This term is sometimes applied to all valves which are opened and shut by hand, but its proper application is to those valves which are of the form of a frustum of a cone, or conoid, turning in a seat of the same figure.

In the most common form of cock, the seat is a hollow cone of slight taper, having its axis at right angles to the pipe in whose course it occurs. The valve is a cone fitting the seat accurately, and having a transverse passage through it of the same figure and size with the bore of the pipe, so that in one position it forms simply a continuation of the pipe, and offers no obstruction to the current, while by turning it into different angular positions, the opening may be closed either partially or wholly. A screw and washer at the smaller end of the cock serve to tighten it in its seat. "Schiele's curve" (Article 14) is sometimes used for cocks.

In a form of cock much used for fire plugs, a short vertical pipe rising from a water main terminates in a hollow conical frustum, tapering slightly upwards, and having an orifice in its side leading into a lateral pipe. Inside the hollow cone is the valve, being another cone, also hollow, open at the base, closed at the top, and having an orifice in its side of the same size and figure with that in the outer cone. This inner cone is pressed upwards into the outer cone by the water within and below it, which thus tends to keep the joint between the cones water-tight; and by turning the inner cone into various angular positions, the lateral orifice can be fully opened, or partially or wholly closed.

123. **Flexible Tube and Diaphragm Valves.**—A class of valves has lately been introduced, in which an india rubber or gutta percha pipe, which when fully open is cylindrical, can be wholly or partially closed by pinching it as if in a vice, by means of a screw.

In another class of valves, the mouth of a cylindrical pipe, from which a current of water is discharged, has opposite to it a flexible circular diaphragm of india rubber, of larger diameter than the pipe, fixed at the edges at such a distance from the pipe as to leave a sufficient passage for the fluid between the edge of the pipe and the face of the diaphragm. Behind the diaphragm is a round, slightly convex stopper or plug, which, when pushed forward by means of a screw, presses the diaphragm tightly against the mouth of the pipe, and so closes the passage.

SECTION 3.—*Plungers, Pistons, and Packing of Water Pressure Engines.*

124. A **Plunger** is a metal cylinder, closed at the ends, and accurately turned on the cylindrical surface, which, in a single acting pump or water pressure engine, acts at once as piston and as piston rod, by having a reciprocating motion in a cylinder. The internal diameter of the cylinder is larger than that of the plunger by an amount sufficient to prevent their touching. Round the circular aperture through which the plunger works is a water-tight "cupped leather collar," to be described in the next Article. A section of a cylinder showing a plunger working in it is given in fig. 37, a few pages farther on.

The area of the transverse section of the *plunger*, and not that of the cylinder in which it works, is to be used in computing the effort exerted by the pressure of the water upon it.

The weight of a plunger is often made considerable, and sometimes a load also is placed upon it, in order that energy may be stored in lifting it, and restored when it descends.

To exemplify the mode of adjusting the weight and load of the plunger for that purpose, let W denote the gross weight of the plunger and load of a single acting water pressure engine, which is to be adjusted in such a manner that the useful resistance overcome during the ascent and descent of the plunger shall be equal. Let R_0 denote that useful resistance.

Let P_1 be the effective effort of the water on the plunger during the up stroke; P_2 , if positive, the excess of the effort of the atmosphere above the resistance from back pressure of the water during the down stroke. If the latter quantity is the greater, P_2 becomes negative, and its sign must be reversed in the following equations (see Article 110):—

Let R_1 be the friction during the up stroke, and R_2 during the down stroke. (As to the friction of the collar, see the next Article.) Then, during the up stroke, when W is a resistance,

$$R_0 = P_1 - R_1 - W ; \dots\dots\dots(1.)$$

and during the down stroke, when W is an effort,

$$R_0 = P_2 - R_2 + W ; \dots\dots\dots(2.)$$

then subtracting (1) from (2), and dividing by 2, we find,

$$W = \frac{P_1 - R_1 - P_2 + R_2}{2} \dots\dots\dots(3.)$$

125. The **Cupped Leather Collar** through which a plunger works is shown in section on a small scale in fig. 37, farther on, and on a larger scale in fig. 38. It resembles in shape an inverted annular channel; and is lodged in an annular recess surrounding the plunger. Its hollow channel is turned towards the inside of the cylinder; and the water, tending to enlarge that channel, presses its outer side against the recess, and its inner side against the plunger, and so keeps a water-tight joint.

From experiments by Messrs. More, and by the Author, it appears that the friction between a plunger and its collar is about *one-tenth* of the total effort of the water on the plunger, at all events somewhere between $\frac{1}{10}$ and $\frac{1}{11}$.

Smaller cupped leather collars are used as packing for the orifices through which piston rods and valve spindles work. The friction between a piston rod and its collar may be estimated at one-tenth of the pressure of the water upon an area equal to the cross-section of the rod or spindle.

Leather collars should be kept always wet, if possible.

126. **Leather Packed Piston.**—A piston is distinguished from a plunger by accurately fitting the cylinder in which it works, so as to be water-tight, and by being of no greater thickness than is necessary to make it water-tight. It is attached to a rod, strong enough to transmit the effort that acts on it to the mechanism which it drives (see Articles 61, 71). The water acts on one face of the piston, or on both, according as the engine is single acting or double acting.

When the water acts on that side of the piston from which the rod extends, the cylinder cover has a stuffing box in its centre, through which the rod works; and the opening is made water-tight by a leather collar, as already described, or by hempen packing.

In computing the effort exerted by the water on that side of the piston from which the rod extends, the *sectional area of the rod is to be deducted from the area of the piston*; in other words, the effective area of the piston on that side is less than the total area in the ratio

$$1 - \frac{d'^2}{d^2} : 1;$$

where d' is the diameter of the rod, and d that of the piston.

When the piston is to be packed by means of leather, its disc, which fits the cylinder easily (and to which the rod is firmly attached by a screw, or a screw and nut, or a key), is made slightly concave on the upper and under faces; then on each of those faces is placed a leather ring, shaped somewhat like a saucer with a hole in the centre, and having its edge turned up all round so as to press

flat against the inside of the cylinder for a breadth of an inch, or an inch and a-half, or thereabouts. The edges of those leather rings are thus turned opposite ways, that of the upper ring upwards, and that of the lower ring downwards. Each of the rings is held in its place by a round saucer-shaped guard or piston cover, bolted or screwed to the body of the piston.

The friction of such pistons, like that of plungers, is found to be about *one-tenth* of the effort of the water.

A piston, like a plunger, may be loaded for the purpose of storing energy, and according to the same principles.

127. **Hempen Packing.**—The body of a piston which is to be packed with hemp is from two to four inches less in diameter than the cylinder in which it is to work; and its depth is about one-sixth of the diameter of the cylinder. It bulges a little at the middle of its depth. Round its base there projects a horizontal flange, whose rim fits the cylinder easily. Above that flange and round the body of the piston is wrapped the packing, consisting either of loose hemp, or of a soft loosely spun hempen rope, called "gasket," soaked with grease. Above the packing is a ring of the same size and figure with the flange, for pressing the packing down, and causing it to fit tightly in the cylinder. This "junk-ring" is held down and can be moved towards the flange so as to compress the packing when required, by means of screws.

The stuffing box of a piston rod is packed with hemp in a similar manner, the hemp being pressed down and made to fit tightly round the piston rod by means of the stuffing box cover and its bolts or screws.

SECTION 4.—*Of Hydraulic Presses and Hoists.*

128. The **Hydraulic Press** is supplied with water from an artificial source, as stated in Article 97, and is therefore not a prime mover, but a piece of mechanism for conveniently applying the energy of the muscular power, or steam power, by which its supply pumps are worked. It is described here first on account of its exemplifying in a simple form various parts which enter into water pressure engines generally.

Fig. 36 is an elevation of a hydraulic press supplied by a hand forcing pump; fig. 37 is a vertical section of the cylinder and pump; and fig. 38 represents the plunger collar: these figures have already been referred to in Articles 124, 125. Fig. 39 is the safety valve, differing from that previously shown in Article 113 only in being so small that the spindle is of as great diameter as the valve.

A is the press cylinder, made thick enough to resist the pressure, according to the principles of Article 64. The bottom should be

segmental or hemispherical, not flat. B is the plunger; Q its collar (see Articles 124, 125); C a plate carried on the head of the

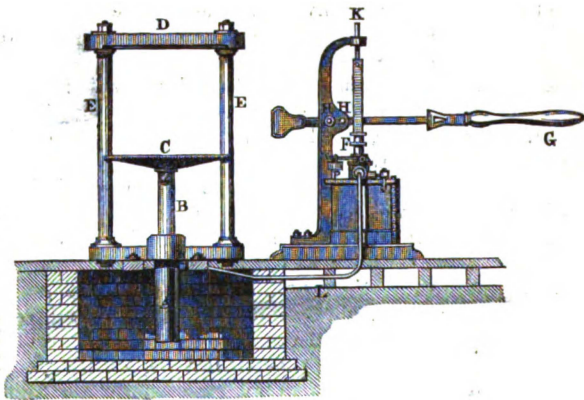

Fig. 86.

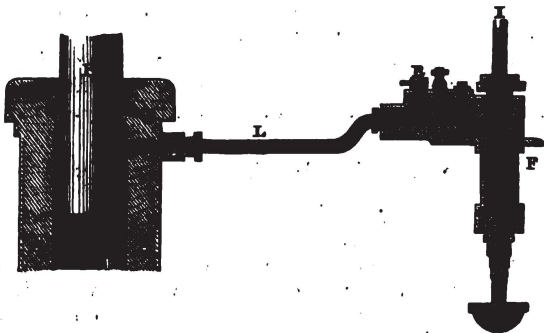

Fig. 87.



Fig. 88.



Fig. 89.

plunger; D the upper plate of the press; E standards guiding the motion of the plate C, and strong enough to resist a working tension equal to the force to be exerted by the plunger. F is the

pump cylinder, I its plunger, and K a guide for the plunger rod. G is the pump handle; H and H' are two alternative centres, about either of which it can be made to work, so as to give a greater or a less leverage as required. L is the supply pipe of the press cylinder, through which water is forced into it by the pump. It contains a self-acting clack, N, opening towards the press cylinder, to prevent the return of water towards the pump. M is the supply valve or suction valve of the pump, being a clack opening upwards; O is the safety valve, P its weight; R the escape valve or discharge valve, being a conical plug worked by means of a screw, kept shut while the plunger is being raised, and opened, so as to let the water escape from the press cylinder, when the plunger is to be allowed to descend by its weight. The discharge pipe, leading from this valve to a tank from which the pump draws its water, is the *tail race* of the machine.

The following formulæ relate to the efficiency of the hydraulic press, and show how to compute the force and the energy required to work it.

Let R be the useful resistance to be overcome by the plunger in rising, and v the velocity with which it is to rise in feet per second. Then the useful work per second is

$$R v \dots \dots \dots (1.)$$

Let W be the weight of the plunger; then $R + W$ is the *gross load* of the plunger. To this has to be added, for friction, a quantity estimated approximately at about *one-tenth* of the gross load; so that the effort of the water on the plunger is nearly

$$P = \frac{11}{10} (R + W) \dots \dots \dots (2.)$$

Let A be the area of the transverse section of the plunger. Then the intensity of the effective pressure of the water in the press cylinder ought to be

$$p = \frac{P}{A} = \frac{11 (R + W)}{10 A} \dots \dots \dots (3.)$$

in pounds on the square foot or square inch, according as A is in square feet or square inches.

Let a' be the sectional area of the supply pipe L; then $\frac{A v}{a'}$ is the velocity with which the water flows through that pipe; and $\frac{v^2 A^2}{2 g a'^2}$ the height due to that velocity.

Let $\Sigma \cdot F$ be the sum of the various *factors of resistance* due to the length and diameter of that pipe, and the several bends, knees, contractions, enlargements, and other causes of resistance which occur in its course, computed according to the principles of Article 99. The head due to the velocity of the current in the pipe is lost owing to the sudden enlargement of the channel in entering the cylinder. Hence the loss of head in the pipe is

$$h = (1 + \Sigma \cdot F) \frac{v^2 A^2}{2 g a^2} \dots \dots \dots (4.)$$

Let $p' = D h$ be the pressure equivalent to this loss of head. Then

$$p + p' \dots \dots \dots (5.)$$

is the pressure in the pump; and if a be the area of the pump plunger,

$$a (p + p') \dots \dots \dots (6.)$$

is the effort to be exerted by it on the water, with a velocity $\frac{A v}{a}$; so that the energy exerted per second by the pump plunger on the water is

$$v A (p + p') \dots \dots \dots (7.)$$

To this has to be added an allowance for the friction of the pump, which, as it includes not only the friction of the plunger collar, but that of the mechanism and valves, may be estimated at about one-fifth of the effort on the water; giving for the whole energy expended per second,

$$\frac{6}{5} v A (p + p') \dots \dots \dots (8.)$$

Comparing this with the expression (1) for the useful work, it appears that the *efficiency* of the machine is

$$\frac{5}{6} \cdot \frac{R}{A (p + p')} = \frac{\frac{5}{6} \cdot R}{\frac{11}{10} (R + W) + A p'} \dots \dots \dots (9.)$$

Let n be the ratio of the velocity of the pump handle to that of the pump plunger; then

$$\frac{n A v}{a} \dots \dots \dots (10.)$$

is the *effective velocity* of the pump handle, reckoning down strokes only, and

$$\frac{6 a (p + p')}{5 n} \dots\dots\dots(11.)$$

is the *effort* required there. The effort which would have been required, had there been no friction and no loss of head, and no load except the useful load, would have been

$$\frac{a R}{n A'} \dots\dots\dots(12.)$$

being less than the actual effort (11) in the same proportion in which the efficiency (9) is less than unity.

In order to produce a continuous current of water into the press cylinder, there are sometimes a pair of pumps having their plungers connected to the opposite arms of a lever with two arms of equal length, so as to perform their down strokes alternately. At the end of each arm of the lever is a cross bar for the workmen to lay hold of.

When the pumps are worked by a steam engine, it is usual to have a set of three, with their plungers respectively connected with three cranks on one shaft, making angles of 120° with each other. Let *s* be the length of stroke of one of them, *a* the area of its plunger, *T* the number of *revolutions* made by the shaft in a second; then, as the quantity of water required per second is *v A*, we must have

$$3 T a s = v A \dots\dots\dots(13.)$$

The hydraulic press may be worked by water from a natural source; in which case the waste of energy owing to the friction of the pump disappears, and the efficiency becomes simply

$$\frac{R}{A (p + p')} \dots\dots\dots(14.)$$

the flow and total head required to drive the machine being respectively

$$Q = v A \dots\dots\dots(15.)$$

$$H = \frac{p + p'}{D} \dots\dots\dots(16.)$$

129. Water Pressure Hoists and Purchases.—The simplest water pressure hoist is a hydraulic press, having on the top of its press plunger a cross-head, from the ends of which hang chains for lifting a load. Such was the apparatus used in raising the girders of the Britannia Bridge.

For this machine, R , in the equations of the preceding Article, represents the load to be lifted, and W the weight of the plunger, cross-head, and chains.

To a similar class belongs the water pressure hoist or purchase invented by Mr. Miller for dragging ships up the inclined plane of "Morton's slip." In this machine the press cylinder is placed at the upper end of the inclined plane, and at an inclination equal to that of the plane; and the tractive force is exerted upon the chain which drags the vessel either by a plunger with a cross-head, or by a piston with a piston rod passing through a stuffing box in the bottom of the cylinder; the effective area of piston A in the latter case being the total area less than the sectional area of the piston rod.

Let i denote the angle of inclination of the slip;

f , a co-efficient of friction, whose value is about $\frac{1}{10}$;

W_1 , the weight of the ship;

R_1 , her total resistance to being dragged up the slip; then

$$R_1 = W_1 (\sin i + f \cos i) \dots \dots \dots (1.)$$

and if v be the velocity with which she is to be dragged, the *useful work per second* is

$$R_1 v \dots \dots \dots (2.)$$

Let W_2 be the weight of the cradle, chains, piston or plunger, and every additional weight which moves along with them; then the resistance

$$R_1 + R_2 = (W_1 + W_2) (\sin i + f \cos i) \dots \dots \dots (3.)$$

is to be substituted for $R + W$ in equations 2, 3, and 9, of Article 128, when the formulæ of that Article will all become applicable to the machine now in question.

130. **Water Pressure Cage Hoist.** — A water pressure hoist for raising and lowering a cage containing mineral wagons, or other heavy bodies, consists essentially of the following parts:—

I. II. III. A frame, carrying pulleys, a chain passing over the pulleys, and a cage hung to one end of the chain, as already described for a bucket hoist in Article 101.

IV. A vertical or nearly vertical *hoist cylinder*, firmly fixed to one side of the frame, and having a leather packed piston (Article 126) with a piston rod passing upwards through a stuffing box in the cylinder cover. The upper end of the piston rod carries a pulley, usually about thirty or thirty-six inches in diameter. The chain is carried under this pulley, and its end made fast to the top of the frame; the effect of which is, that the velocity of the piston is one-half of that of the cage; and the length of stroke of the piston is one-half of the lift.

V. The *supply pipe* of the hoist cylinder; having, near the hoist cylinder, its regulator, which is a screw slide valve, opened and shut by hand.

VI. The *discharge pipe* of the hoist cylinder, having also its screw slide valve. As to *relief clacks*, see Article 134 A.

VII. The *store cylinder*, from which the supply pipe of the hoist cylinder comes, resembles a hydraulic press, with its collared plunger. It is destined to contain a reserve of water to supply the hoist when it is occasionally worked so rapidly as to expend water faster than the source can supply it. The store cylinder is replenished with water from the source in the intervals when the hoist is standing idle. The plunger of the store cylinder is loaded with a weight corresponding to the pressure required. The same store cylinder, if large enough, may answer for several hoists.

The store cylinder may also be made like a hydraulic press inverted, the plunger being fixed, and standing on a firm foundation, with the supply and discharge pipes traversing it; and the cylinder being moveable, with its collared end downwards, and its closed end upwards, and a sufficient weight placed upon it.

VIII. The supply pipe of the store cylinder.

IX. The source, which may be an elevated reservoir, or a water work main giving a sufficient flow and pressure, but which is much more frequently artificial, being a set of forcing pumps worked by a steam engine, as described in Article 128.

The following are the formulæ applicable to machines of this kind.

Let R_1 be the useful load to be lifted, s_1 the height to which it is to be lifted in the time t with the velocity $v_1 = s_1 \div t$; then the *useful work per second* is

$$R_1 v_1 \dots \dots \dots (1.)$$

An ordinary value of v_1 is *one foot per second*.

For a first rough estimate of the power required to produce this effect, the efficiency of the whole machine may be taken approximately at $\frac{2}{3}$; so that the *energy expended per second* will be

$$D Q H = \frac{3}{2} R_1 v_1, \text{ nearly.} \dots \dots \dots (2.)$$

The object of making this rough estimate is to fix the size of the hoist cylinder. If the source is a reservoir or a water work pipe, the total head H is in general fixed; if the source is artificial, there are in most cases reasons which fix a limit to H ; it is seldom, for example, desirable to exceed 500 or 600 feet. The value of H having been fixed approximately, we have for the flow of water per second while the cage is being lifted—

$$Q = \frac{3 R_1 v_1}{2 D H}; \dots\dots\dots (3.)$$

and for the flow *per stroke* of the hoist, which is the effective volume of the hoist cylinder—

$$Q t = \frac{3 R_1 s_1}{2 D H} = \frac{A_1 s_1}{2} \dots\dots\dots (4.)$$

A_1 being the *effective area* of the piston; that is, the excess of the area of the piston above that of the piston rod; and $s_1 \div 2$ its length of stroke, so that

$$A_1 = \frac{2 Q t}{s_1} = \frac{3 R_1}{D H} \dots\dots\dots (5.)$$

When H is limited to 500 feet, the piston rod may be made one-fiftieth of the area, or about one-seventh of the diameter, of the piston; so that we shall have in that case—

$$\text{Diameter of piston} = \sqrt{\frac{50 \cdot A_1}{49 \times 7854}} = 1.14 \sqrt{A_1} \dots (6.)$$

Let W_1 be the weight of the cage; then

$$R_1 + W_1 \dots\dots\dots (7.)$$

is the *working tension on the chain*; and six times this should be the ultimate strength of the chain. Let W_2 be the weight of the chain and pulleys; then

$$R_2 = \frac{R_1 + W_1}{10} + \frac{W_2}{20} \dots\dots\dots (8.)$$

will be very nearly the *friction of the mechanism*.

Inasmuch as by the tackle used, the velocity of the piston is half that of the chain, we shall have for the *tension on the piston rod*—

$$2 (R_1 + R_2); \dots\dots\dots (9.)$$

to which adding one-tenth for the friction of the piston and rod, we find for the *effort p A*, and intensity of *pressure p*, exerted by the *water on the piston*—

$$\left. \begin{aligned} p A &= \frac{22}{10} (R_1 + R_2). \\ p &= \frac{22}{10} \cdot \frac{R_1 + R_2}{A_1}. \end{aligned} \right\} \dots\dots\dots (10.)$$

The loss of head by the *resistance of the supply pipe*, and the corresponding pressure, are found as in equation 4 of Article 128,

with due attention to the formulæ of Article 99. Let p' be the pressure so found. Then

$$p + p' \dots \dots \dots (11.)$$

is the *pressure in the store cylinder when its plunger is falling.*

Let A_2 be the area of the plunger of the store cylinder, to be fixed in a manner which will be afterwards explained. Then adding one-ninth for the friction of the collar, we have—

$$\frac{10}{9} (p + p') A_2 \dots \dots \dots (12.)$$

for the *gross load of the store cylinder plunger, including its own weight.*

The pressure in the store cylinder *when its plunger is rising* is

$$\frac{11}{9} (p + p') \dots \dots \dots (13.)$$

and *not only the store cylinder but the hoist cylinder and supply pipe* ought to have their strength adapted to this working pressure, by making their bursting pressure six-fold, and using the rules of Article 64.

Let p'' be the pressure due to the resistance of the supply pipe leading from the source to the store cylinder; then

$$D H_1 = p_1 = \frac{11}{9} (p + p') + p'' \dots \dots \dots (14.)$$

is the pressure corresponding to the total head required at the source, natural or artificial. Should the head H_1 calculated by this formula prove greater than the head H originally assumed, the supply pipes should be made larger, so as to diminish their resistance until H_1 does not exceed H . As to this, see Article 108.

Then the *energy expended by the water for each second* that the hoist works is

$$p_1 Q = D Q H_1, \dots \dots \dots (15.)$$

and the *efficiency of the fall of water* is

$$\frac{R_1 v_1}{p_1 Q} \dots \dots \dots (16.)$$

If the source is artificial, the work lost in overcoming the friction of the pumps or other mechanism used in producing it is to be added to $p_1 Q$ in estimating the whole energy expended per second of working of the hoist and the resultant efficiency of the entire machine.

A single store cylinder and a single source or set of pumps may supply either one hoist or several. To find the rate of flow from

the pumps or other source into the store cylinder, ascertain the length of the interval during which the hoists usually stand idle, and add to it the length of the following interval during which they are at work. Let T be the number of seconds in the *whole period* so found; and of these seconds let T_1 be the number of seconds during which any hoist is *rising*, and Q the quantity of water it requires per second while rising. Then summing the quantities for all the hoists—

$$\Sigma \cdot Q T_1 \dots \dots \dots (17.)$$

is the quantity of water required in each period of T seconds; so that the uniform rate of flow from the source into the store cylinder should be

$$Q_1 = \frac{\Sigma \cdot Q T_1}{T}; \dots \dots \dots (18.)$$

giving for the uniform power of the fall, in foot-pounds per second, $D Q_1 H_1$.

The capacity *absolutely necessary* for the store cylinder is

$$s_2 A_2 = \Sigma \cdot Q T_1 - Q \Sigma \cdot T_1 \dots \dots \dots (19.)$$

(s_2 being its length of stroke); but it is in general advisable to make

$$s_2 A_2 = \Sigma \cdot Q T_1 \dots \dots \dots (19 A.)$$

In the preceding description, the chain tackle is supposed to be so arranged that the velocity of the hoist cylinder piston is one-half of that of the cage; but any required velocity-ratio can be given by suitably arranged fixed and moving pulleys. This combination in mechanism of chain-and-pulley tackle, with hydraulic connection, was first introduced by Sir William Armstrong, who has applied it not only to hoists but to cranes and various other machines. (See *Trans. of the Inst. of Mechanical Engineers*, Aug., 1858.)

SECTION 5.—Of Self-Acting Water Pressure Engines.

131. **General Description.**—When a “water pressure engine” is spoken of without qualification, it is generally a self-acting water pressure engine that is meant; that is, an engine which differs from a mere press, hoist, or crane, in having *distributing valves* for regulating the supply and discharge of the water, which are moved, directly or indirectly, by the engine itself; so that it is a machine having a periodical motion, which motion having once been made to commence, goes on of itself until it is stopped, either by shutting

the throttle valve and so stopping the supply of water, or by disengaging or otherwise stopping the valve motion.

The distributing valves are in general of the *piston valve* kind (Article 121), and worked by a small auxiliary water pressure engine.

Inasmuch as the friction of water in passages varies as the square of the velocity, and the work performed in overcoming it as the cube of the velocity (other things being equal),—and inasmuch as the velocity for a given flow of water varies inversely as the area of the passage:—it is favourable to the efficiency of a water pressure engine, which is to perform useful work at a given rate, that its dimensions should be made as large and its movement as slow as is consistent with due economy of first cost in each particular case.

It is also favourable to efficiency that the stroke of the piston should be long; for the reversal of its motion is seldom unaccompanied by shock; and at each such reversal the position of the valves has to be altered; both of which cause loss of work.

The most advantageous use, therefore, to which a water pressure engine can be applied is the pumping of water, to which slow motion and a long stroke are well adapted, because they are favourable to efficiency, not only in the engine but in the pump which it works.

Nevertheless, in situations where a large supply of water at a high pressure can easily and cheaply be obtained, water pressure engines have been used with advantage where considerable speed is requisite, as in driving rotating machinery. Various engines of this kind have been designed and executed by Sir William Armstrong.

The whole of the mathematical principles which apply to water pressure engines have been explained in the preceding sections of this chapter.

Their resultant efficiency, as ascertained by practical experience, is stated by different authorities at values ranging from 0.66 to 0.8. The variations probably arise chiefly from differences in the resistance of the passages traversed by the water, and perhaps also to some extent from errors in the mode of calculating the quantity of water used.

In estimating the probable efficiency of any proposed water pressure engine, the lowest value of the efficiency, viz., 0.66, is of course the safest to assume as a rough estimate; but a closer approximation may be obtained by making a calculation according to the method already exemplified in detail in Articles 128 and 130; that is, commencing with the resistance of the useful work and the velocity of the piston, and computing in their order all the

different prejudicial resistances to be overcome, and the quantities of work to be performed in overcoming them.

132. **Single Acting Water Pressure Engine.** — The example chosen to illustrate this kind of water pressure engine is a mine pumping engine, designed by M. Junker, as described by Mr. Delaunay. It resembles in many respects the pumping engines of Mr. Darlington.

Fig. 40 is a complete vertical section of the engine, during the *induction*, or admission of the water to the cylinder.

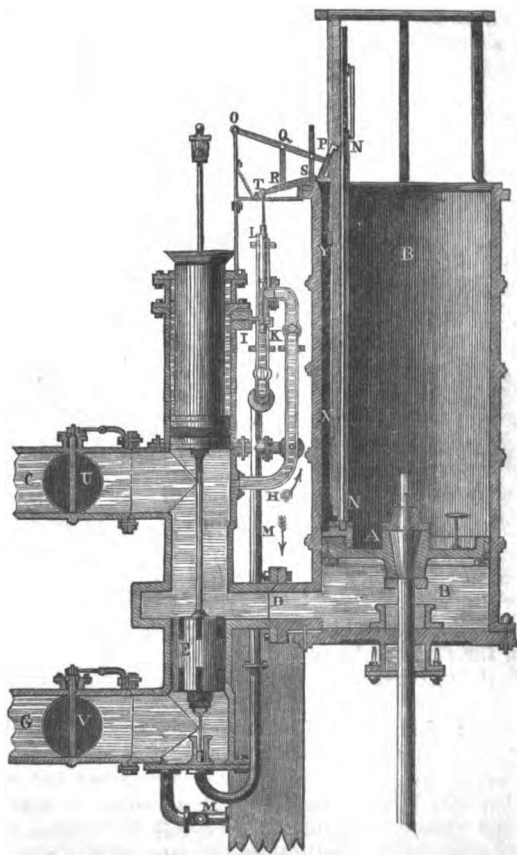

Fig. 40.

Fig. 41 is a vertical section of the valve ports and passages during the *eduction*, or discharge of water from the cylinder. Both figures are lettered alike.

A is the main piston, which lifts the pump plunger rod by means of a rod traversing the bottom of the main cylinder B B.

C is the supply pipe, and U its throttle valve.

D is the valve port, consisting of a pipe connecting the bottom of the cylinder with an annular passage surrounding the valve cylinder, as already described in Article 121.

E is the piston valve.

G the discharge pipe, and V its throttle valve.

When E is below D, as in fig. 40, D communicates with C, and water is admitted into the cylinder to raise the main piston. When E is above D, as in fig. 41, D communicates with G, and the water is discharged from the cylinder during the descent of the main piston. The piston valve E is notched at the edges, in the manner shown in the figure, in order that the opening and closing of the port may take place by degrees—the water flowing partially through the notches for a short time before and after the edge of the piston arrives at the edge of the ports.

The valve cylinder consists of two parts of unequal diameter, the upper being the larger. In the lower, or smaller part, the piston valve E works. In the upper, or larger part, wholly above the supply pipe, works the *counter-piston* F; this being larger than E, and fixed to the same rod, the pressure of the water between E and F tends to raise them both. The upper side of F is provided, if necessary, with a rod, or a "*trunk*" (that is, a hollow piston rod), passing through a stuffing box in the top of the valve cylinder. The use of this is to diminish the effective area of the upper side of F, so that it shall not be more than is requisite to enable the pressure of the water, when admitted through the port I into the space above F, to overcome the friction of the piston valve and its appendages, together with the excess of the pressure on the lower

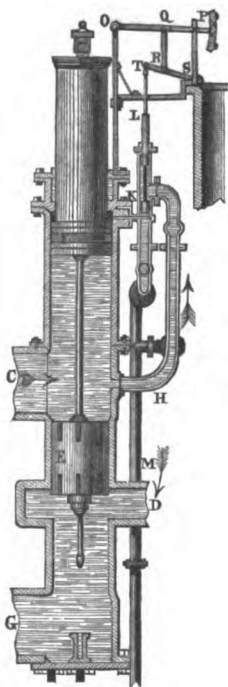

Fig. 41.

side of F above the effective pressure on E. The sectional area of this rod or trunk, therefore, should be about as much less than the area of E as the area of E is less than the whole area of F.

H is the supply pipe and M the discharge pipe of the part of the valve cylinder above the counter-piston, which, with its cylinder, forms an auxiliary engine to work the valve of the principal engine. K is the piston valve of this auxiliary engine, which regulates the admission and discharge of the water through the port I, exactly as the main piston valve E regulates the admission and discharge of the water through the port D of the main cylinder. L is a plunger of the same size with K, and fixed to the same rod, in order that the pressure of the water in the space between K and L may not tend to move the piston valve K either upwards or downwards.

The auxiliary valve rod to which K and L are fixed is connected by means of a train of levers and linkwork marked O Q R S T, with a lever carrying on its end a "*crutch*," P. N is a vertical "*tappet rod*," carried by the main piston A, from which project the tappets X and Y for moving the crutch P.

The engine works in the following manner:—

Suppose, as in fig. 41, that the main piston valve E is raised, the water escaping by the route D G from the main cylinder, and the main piston falling. When the main piston approaches the bottom of its stroke, the upper tappet Y strikes the lower hook of the crutch P, and depresses it, together with the auxiliary piston valve K.

This admits water from the main supply pipe C, by the route H I, to the annular space above the counter-piston F, so as to depress it, together with the main piston valve E, into the position shown in fig. 40. Then the water from the main supply pipe passes through D into the main cylinder B B, and lifts the main piston A. When the main piston approaches the top of its stroke, the lower tappet X strikes the upper hook of the crutch P, and raises it, together with the auxiliary piston valve K.

This allows the water to be discharged from the annular space above the counter-piston F, by the route I M; so that the pressure of the water between F and the main piston valve E upon the excess of the area of F above that of E, raises F and E together back to the position shown in fig. 41, cuts off the supply of water to the main cylinder, and opens the passage for the discharge of water from the main cylinder through D into G. The main piston then descends, thus completing a double stroke, and the entire cycle of operations recommences. The process may be summed up by saying, that of the two engines, the main and the auxiliary, each works the valve of the other.

The frequency of the strokes of the engine depends on the speed with which the valve mechanism works; and this can be controlled by means of regulating cocks on H and M, the supply and discharge pipes of the auxiliary engine.

133. A **Double Acting Water Pressure Engine** has a main cylinder, whose ends are both closed, the main piston rod passing out through a stuffing box in one of them, and each end being provided with a port like D in figs. 40 and 41, communicating with one valve cylinder, both of whose ends communicate with the discharge pipe. The supply pipe enters the valve cylinder at the middle of its length. On one rod are carried a pair of equal and similar piston valves, one for each port, which rise and fall together: the distance between them is so adjusted, that when they are raised, and the upper piston valve leaves the upper port in communication with the supply pipe, the lower piston valve at the same time leaves the lower port in communication with the discharge pipe through the lower end of the valve cylinder—and that when they are depressed, and the lower piston valve leaves the lower port in communication with the supply pipe, the upper piston valve at the same time leaves the upper port in communication with the discharge pipe through the upper end of the valve cylinder.

The valve piston rod may be moved either directly by tappets, or indirectly by a small auxiliary engine.

134. **Rotative Water Pressure Engines.**—In this class of engine, the cylinders are either double or single acting, and the piston rods, by means of connecting rods and cranks, drive a shaft. In order to diminish as much as possible the variations of the effort upon the crank shaft, it is usual to have two, three, or four cylinders acting in succession; but a single cylinder would answer, if the fly wheel were made of sufficient inertia.

The inertia of the fly wheel for a rotative water pressure engine is to be determined by the same rule as for a non-expansive steam engine. (See Articles 52, 53.)

The frequency of the strokes is greater in this than in other kinds of water pressure engines; and therefore, to avoid great resistance, the supply and discharge pipes, and the valve ports, must be larger as compared with the piston than in other water pressure engines. The best rule is to make, if practicable, every passage of such an area, that the velocity of the water in it shall not exceed the maximum velocity of the pistons. The best valves appear to be double piston valves. Engines of this kind are very useful and convenient for driving small machines in towns where there is a copious supply of water at a high pressure; and also in mines, where steam engines might be inconvenient or unsafe. In the

latter situation they may be driven by a portion of the water which is pumped up by the draining engine of the mine.

The most successful in practice of rotative water pressure engines are those of Sir William Armstrong, as to which, and as to hydraulic cranes and hoists, detailed information may be found in the *Transactions of the Institution of Mechanical Engineers*, August, 1858. Their efficiency is roughly estimated at from .66 to .77.

134 A. **Relief Clacks** form an important part of the engines of Sir William Armstrong. Their object is to prevent the shocks which would otherwise occur within the cylinder on the closing of the port, and consequent sudden stopping of the motion of the water. A set of relief clacks for a single acting cylinder consists of two, one opening upwards, in a passage leading from the cylinder port into the supply pipe, and the other opening upwards, in a passage leading from the discharge pipe into the cylinder port. The effect is, that the pressure in the cylinder cannot rise above that in the supply pipe, nor fall below that in the exhaust pipe.

For a double acting cylinder, four clacks are required, two for each port.

Supplement to Part II., Chapter IV., Section 2.

134 B. **Compound Clacks** for large pumps are now much used, in which the general form of the compound seat is like a cone with its vertex upwards, and an inclination of from 45° to 75° ; but the sides do not slope, being formed into a series of flat circular steps. Each of those flat steps is pierced with a ring of openings, and forms the seat of a clack or set of clacks, prevented from rising too high by a projecting or overhanging portion of the step next above. When there is a single clack to each step, it is a ring of metal or india rubber; when a set of clacks, they are leather flaps or india rubber balls. (See a paper by Mr. John Hosking, *Trans. Inst. of Mech. Engineers*, August, 1858.)

SECTION 6.—*Of Water Pressure Engines with Air Pistons.*

135. The **Hungarian Machine** is the name given to an engine first used for pumping mines at Chemnitz, in Hungary, in which the duty of a piston is performed by a mass of confined air, transmitting pressure and motion from a stream of water whose fall constitutes the source of power, to another mass of water, whose elevation to a given height is the useful work to be performed. Its principle is identical with that of a piece of apparatus known as "Hero's Fountain," from having been described in the *Pneu-*

matics of Hero of Alexandria, a philosopher who flourished in the second century B. C.

The flow of the fall must exceed the quantity of water to be raised in a given time, and the head must exceed the height to which that water is to be raised, in proportions whose approximate values will afterwards be pointed out.

The principal parts of the machine are indicated in fig. 42.

A, a tank or well at the bottom of a shaft, for collecting the water to be raised.

B, an air-tight receiver, of sufficient strength to resist the greatest internal pressure that acts in the apparatus, wholly immersed in the water of the well. This may be called the *pump barrel*. The bottom of the receiver must not touch the bottom of the well, for there must be space enough between to admit the access of the water of the well to

C, a clack opening inwards, in the bottom of the receiver B.

D, a delivery pipe, rising from near the bottom of B to the drain at the top of the shaft which carries away the water raised. It is desirable, though not absolutely necessary, to have at the bottom of D a clack opening upwards.

E, an air-tight receiver, at least as strong as B, which corresponds to the *cylinder* of a common water pressure engine, and is placed in any site near the top of the shaft which is convenient for discharging the water of the driving source after it has done its work. This may be called the *working barrel*.

F, the *air pipe*, connecting the top of the pump barrel B with the top of the working barrel E.

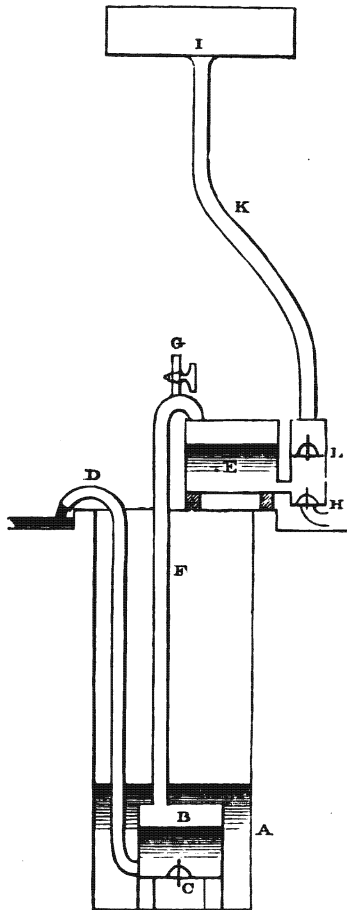

Fig. 42.

G, the *waste air cock*, at the top of E.

H, the *discharge valve*, at the bottom of E, for discharging the water which has performed its work in the working barrel.

I, a reservoir, at the top of the fall.

K, the *supply pipe*, connecting that reservoir with the bottom of the working barrel E.

L, the *admission valve*, near the bottom of the supply pipe.

The valves H and L may be opened and shut by floats in the working barrel, or by a small auxiliary water pressure engine, or by a small wheel driven by the water discharged. The sketch shows them as spindle valves; but a single piston valve might be made to do the duty of both.

The machine is set to work by opening the air waste cock G, L at the same time being shut. The water from the well A opens the clack C, enters and fills the working barrel B, and drives out the air through G, so that E and F only remain filled with air. Then G is shut, and remains shut while the machine is working; H is shut and L opened, and the working proceeds as follows:—

The driving water from I descends through K and L into E, and compresses the air contained in E and F. The pressure so exerted on that air is transmitted to the water in B, and causes it to rise in the delivery pipe D. When the pressure has become equal to that of the column of water in D added to its resistance, the lifted water issues from D into the drain, and continues to do so until E is filled with water. Then by the valve gearing, L is shut and H opened; and the water in E is made to flow out, partly by its own weight, and partly by the pressure of the expanding air. As soon as the air has fallen to its original pressure, more water from the well flows through C into B, and drives all the air back into F and E. Then H is shut and L opened, and the cycle of operations recommences.

In the following investigation of the efficiency of this engine, the fluctuations of level of the water in the pumping and working barrels, B and E, are neglected in comparison with the height of lift, and the head of fall.

Let h_0 denote the head of water which is equivalent to one atmosphere, or 33·9 feet on an average.

Let h_1 be the height of the outlet of the delivery pipe D above the surface of the water in A; D, the weight of a cubic foot of water, or 62·4 lbs.; Q_1 , the number of cubic feet per second to be raised; then

$$D Q_1 h_1 \dots \dots \dots (1.)$$

is the useful work per second.

Let h_2 be the head lost by the resistance in the pipe D, computed by the principles of Article 99; then

$$h_0 + h_1 + h_2 \dots \dots \dots (2.)$$

is the head of water equivalent to the pressure to which the air must be compressed in E, F, and B, before the water will issue from the outlet of D. That pressure, in atmospheres, may be expressed thus—

$$n = 1 + \frac{h_1 + h_2}{h_0}; \dots \dots \dots (3.)$$

and the working pressure which the barrels and air pipe must be adapted to bear is $n - 1$ atmospheres.

The volume of air which must pass per second from E into B, while the water is being forced out of B, is Q_1 cubic feet at the pressure of n atmospheres.

When air is compressed or dilated so suddenly that it has not time to lose or gain heat by communication with adjoining bodies, its density varies much more slowly than its pressure; but when there is time for all the heat produced by compression to be conducted away, and for all the heat which disappears during expansion to be replaced from neighbouring bodies, the density varies very nearly as the pressure simply. It is probable that the latter supposition is very near the truth in the present case, especially as the air is charged with moisture, which facilitates the communication of heat.

Therefore, as the original pressure of the air, before being compressed by the descent of the water from I into E, is one atmosphere, the volume of the mass of air which descends per second, at the original pressure, is

$$Q = n Q_1, \dots \dots \dots (4.)$$

and this also is the volume of water which must descend from the source per second, in order to perform the work.

Let B and E be taken respectively to represent the capacities of those portions of the pump barrel and working barrel which are alternately filled and emptied of water at each stroke, and let F denote the capacity of the air pipe; then we must evidently have

$$\frac{E + F}{B + F} = n \dots \dots \dots (5.)$$

Let h_3 be the loss of head by the resistance of the supply pipe, valves, &c. Then the *total head* required for the fall is

$$H = h_1 + h_2 + h_3; \dots \dots \dots (6.)$$

so that the *total energy expended per second* is

$$\begin{aligned} D Q H &= n D Q_1 (h_1 + h_2 + h_3) \\ &= \frac{h_0 + h_1 + h_2}{h_0} \cdot D Q_1 (h_1 + h_2 + h_3); \dots\dots\dots(7.) \end{aligned}$$

and comparing this with the useful work in formula 1, it appears that the efficiency of the engine is

$$\frac{Q_1 h_1}{Q H} = \frac{h_1}{n(h_1 + h_2 + h_3)} = \frac{h_0 h_1}{(h_0 + h_1 + h_2) \cdot (h_1 + h_2 + h_3)} \dots(8.)$$

The diminution of efficiency represented by the factor $\frac{1}{n}$ in the above expression, and corresponding to a loss of head to the amount of

$$\left(1 - \frac{1}{n}\right) H,$$

arises from the loss of the energy exerted in compressing the air, and in agitating the water in E and K during the time of that compression, when the head is more than sufficient to produce the entrance of the water with the proper velocity.

The energy exerted in compressing the air is restored during its expansion; but being wholly employed in forcing the water out of the discharge valve H, it is lost in the end.

The chief recommendation of the Hungarian machine appears to be its simplicity.

136. **An Air Vessel** is a sufficiently strong air-tight receiver, generally cylindrical, with a hemispherical top, the upper part of which contains some imprisoned air, while the lower part contains water, and communicates with the cylinder or the supply pipe of a water pressure engine, or any other vessel or passage in which changes of the velocity of a mass of water occur. The compressibility and expansibility of the air, admitting of the alternate flow of a portion of water into and out of the air vessel, enable such changes of velocity to be made by degrees. Rotative water engines were formerly made with an air vessel in connection with each end of the cylinder; but relief valves (Article 134 A) are now considered preferable.

Supplement to Part II., Chapter I., Article 94.

136 A. **Water Meters** are instruments for measuring and recording the flow of water through pipes. Detailed descriptions of several kinds may be found in the *Transactions of the Institution of Mechanical Engineers* for 1856.

The meters now in ordinary use may be divided into two classes: *piston meters* and *wheel meters*.

As an example of a piston meter may be taken Mr. Kennedy's, which is a small double acting water pressure engine, driven by the flow of water to be measured. As it has been found, in other piston meters, that the recording merely the *number of strokes* made by the piston leads to errors in computing the flow, this meter is so constructed that, by means of a rack on the piston rod driving pinions, the *distance* traversed by the piston is recorded by a train of wheelwork, with dial plates and indexes.

An example of a wheel meter is that of Mr. Siemens, being a small *reaction turbine* or "Barker's mill," driven by the flow. The revolutions are recorded by a train of wheelwork, with dial plates and indexes.

Another example of a wheel meter is that of Mr. Gorman, being a small *fan turbine* or *vortex wheel* driven by the flow, and driving the indexes of dial plates.

All those three meters are found to answer well in practice, and can be placed in the course of a pipe under any pressure.

The ordinary errors of a good water meter are from $\frac{1}{2}$ to 1 per cent. ; in extreme cases of variation of pressure and speed, errors may occur of $2\frac{1}{2}$ per cent.

The value of the revolutions of a wheel meter should be ascertained experimentally, by finding the number of revolutions made during the filling of a tank of known capacity.

CHAPTER V.

OF VERTICAL WATER WHEELS.

SECTION 1.—*General Principles.*

137. **Pond and Weir.**—The head race or supply channel of a vertical water wheel commences either at a large store reservoir, being a natural or artificial lake in which the rainfall of a district is collected, or at a smaller reservoir or pond, being an enlargement in the course of a river, formed by building a weir or dam across it. The object of that weir is not merely to store a surplus flow of water at one time, and employ it to supply deficiency of flow at another, but to prolong a high top water level from its natural situation at a place some distance up the stream, to a place as near as possible to the bottom of the fall, where the tail race joins the natural channel, and thus to diminish as far as possible the loss of head arising from friction in the head race and tail race.

The weir, throughout either the whole or a part of its length, acts as a *waste weir* or *overflow*, discharging over its crest the surplus flow of floods, beyond what the wheel can use.

I. *Level of Pond—Weir not Drowned.*—In order to find how high the water in the pond will stand above the crest of the weir, a formula is to be used founded on equation 2 of Article 94, with this difference, that whereas for a sharp edged notch the co-efficient of discharge c is from 0.595 to 0.667, it is considerably smaller for the flat or slightly rounded crest of a weir. Its values under various circumstances have been determined by the experiments of Mr. Blackwell. For the purpose at present in view, it is sufficiently accurate to take the following average value :—

For waste weirs, $c = 0.5$ nearly.....(1.)

This gives for the flow over the weir, in cubic feet per second,

$$Q = 5.35 c b h^{\frac{3}{2}} = 2.67 b h^{\frac{3}{2}} ; \dots\dots\dots(2.)$$

so that the greatest height h , in feet, at which the water in the pond near the weir stands above the crest of the weir is given by the following formula :—

$$h = \sqrt[3]{\frac{Q^2}{7 b^2}} \text{ nearly ; } \dots\dots\dots(3.)$$

Q being the greatest flow in cubic feet per second, and b the breadth in feet of the outlet over the weir crest.

II. *Weir Drowned*.—A weir is said to be “drowned” when the water in the channel below it is higher than its crest. Let h, h' , be the heights of the water above the weir crest, in the pond and in the waste channel respectively; then the flow per second is

$$Q = \frac{2}{3} c b \sqrt{\left\{ 2g(h-h') \right\}} \cdot \left(h + \frac{h'}{2} \right) \dots\dots\dots(4.)$$

when Q and h' are given, the exact determination of h requires the solution of a cubic equation, but the following approximate solution is in general sufficient :—

First approximation,
$$h_1 = h' + \sqrt[3]{\frac{Q^2}{7b^2}} \dots\dots\dots(5.)$$

This always gives too great a result.

Second approximation. An amended value h_2 of h , is given by the formula

$$h_2 = h_1 - h' \left(1 - \frac{5}{4} \cdot \frac{h'}{h_1 - h'} \right) \dots\dots\dots(6.)$$

Closer approximations may be obtained by repeating the process.

138. **Backwater** is the effect produced by the elevation of the water level in the pond close behind the weir, upon the surface of the stream at places still farther up its channel.

For a channel of uniform breadth and declivity, the following is an approximate method of determining the figure which a given elevation of the water close behind a weir will cause the surface of the stream farther up to assume.

Let i denote the rate of inclination of the *bottom* of the stream, which is also the rate of inclination of its surface before being altered by the weir.

Let δ_0 be the natural depth of the stream, before the erection of the weir.

Let δ_1 be the depth as altered, close behind the weir.

Let δ_2 be any other depth in the altered part of the stream.

It is required to find x , the distance from the weir in a direction up the stream at which the altered depth δ_2 will be found.

Denote the ratio in which the depth is altered at any point by

$$\frac{\delta}{\delta_0} = r;$$

And let ϕ denote the following function of that ratio :—

$$\phi = \int \frac{dr}{r^3 - 1} = \frac{1}{6} \text{ hyp. log. } \left\{ 1 + \frac{3r}{(r-1)^2} \right\} + \frac{1}{\sqrt{3}} \text{ arc. tan. } \frac{2r+1}{\sqrt{3}} \quad \dots(1.)$$

A convenient approximate formula for computing ϕ is as follows :—

$$\phi \text{ nearly} = \frac{1}{2r^2} + \frac{1}{5r^6} + \frac{1}{8r^8} \dots\dots\dots(2.)$$

Compute the values, ϕ_1 and ϕ_2 , of this function, corresponding to the ratios

$$r_1 = \frac{\delta_1}{\delta_0} \text{ and } r_2 = \frac{\delta_2}{\delta_0}.$$

Then

$$x = \frac{\delta_1 - \delta_2}{i} + \left(\frac{1}{i} - 264 \right) \cdot (\phi_1 - \phi_2) \delta_0 \dots\dots\dots(3.)$$

The following table gives some values of ϕ :—

r	ϕ	r	ϕ
1.0	∞	1.8	.166
1.1	.680	1.9	.147
1.2	.480	2.0	.132
1.3	.376	2.2	.107
1.4	.304	2.4	.089
1.5	.255	2.6	.076
1.6	.218	2.8	.065
1.7	.189	3.0	.056

The first term in the right hand side of the formula 3 is obviously the distance back from the weir at which the depth δ_2 would be found if the surface of the water were level. The second term is the additional distance arising from the declivity of that surface towards the weir. The constant 264 is an approximation to $2 \div f$, f being the co-efficient of friction. For a natural declivity of 1 in 264, the second term vanishes. For a steeper declivity, it becomes negative, indicating that the surface of the water rises towards the weir; but although that rise really takes place in such cases, the agreement of its true amount with that given by the formula is somewhat uncertain, inasmuch as the formula involves assumptions which are less exact for steep than for moderate natural declivities. It is best, therefore, in cases of natural declivities steeper than 1 in 264, to compute the extent of backwater simply from the first term of the formula.

139. **Waste Sluices** in a wall forming part of the weir are used to enable the surplus water of floods to be discharged with a lower elevation of the surface of the pond, and a less extent of backwater, than would be practicable if all the surplus flow had to pass over the weir-crest.

A *self-acting waste sluice* invented by a French engineer, M. Chaubart, is shown in fig. 43, which is a vertical section. It has been found to answer well where it is required to maintain the surface of the water in a pond or canal very accurately at a certain level.

A B is the sluice or valve plate, represented as shut, its upper edge A being at the proper water level.

The sluice is supported by a pair of cast iron sectors, resting on horizontal platforms. E is one of those sectors; F G its platform. The edge of each sector has a groove, in which lies a chain, fixed at F to the platform, and at H to the sector. This pair of chains resists the tendency of the water to press the sluice forward.

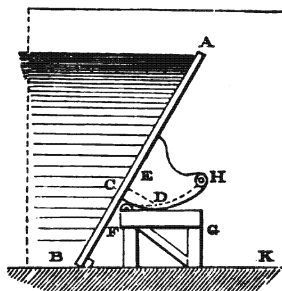

Fig 43.

When the water is at the level of A, the resultant of its pressure acts at a depth \overline{AC} which is *two-thirds* of the whole depth \overline{AB} of the sluice. Through C draw \overline{CD} perpendicular to A B, cutting the *centre line of the chain* F H in D. Then the sectors and platforms must be so formed and placed, that when the sluice is shut, the point of contact of each sector with its platform shall be vertically below D; and then the combined resistance of the chains and platforms will be directly opposed to the pressure of the water, and will balance it.

When the water rises above A, and begins to overflow, the centre of pressure rises above C, so that the pressure and the resistance are no longer directly opposed. The sluice then rolls upon its sectors into a new position of equilibrium, and in so doing, it not only depresses the edge A, so as to make the overflow more rapid, but raises the edge B, so as to make an outlet at the bottom of the passage B K, through which the surplus water escapes much more rapidly than it could do by merely overflowing.

140. **Head Race and Sluices.**—To protect the conduit, which is the head race, from the surplus water of floods, it is advisable that between it and the natural stream there should be a wall or an embankment rising a sufficient height (say from two to three feet) above the highest level of floods; and also that a similar wall or embankment should extend across the upper end of the conduit,

where it leaves the pond. In the latter situation a wall is the more suitable. It is traversed by a passage for admitting water from the pond to the conduit, capable of being closed or opened to a greater or less extent, by means of one or more *sluices*, which are slide valves moving vertically in guides, made of timber or iron, and moved by means of a screw, or of a rack and pinion. It is advisable not to make sluices broader than about four or five feet. If a greater width of opening is required, the passage from the pond into the conduit should be divided by walls or piers into a sufficient number of parallel passages, each furnished with a sluice.

The *loss of head* at a sluice is to be found by the principles of Article 99, Division V.

The channel of the head race is to be made as large as is consistent with proper economy in first cost. Supposing its flow Q in cubic feet per second, and its figure and dimensions, to be fixed beforehand, the declivity which it requires is to be computed by the principles of Article 99, Division VI., equations 13, 15, 16, 17.

Supposing the flow Q , and the rate of declivity $i = h \div l$ (h being the fall), to be given, the figure and transverse dimensions of the channel are to be fixed in the following manner :—

The *form of least resistance* for the cross-section of an open channel of a given area A , is obviously a semicircle; its border b being the shortest which can enclose the given area. Its *hydraulic mean depth* is *one-half of its radius*; that is, r being its radius, and also the maximum depth of water in it, and m the hydraulic mean depth,

$$m = \frac{A}{b} = \frac{r}{2} \dots \dots \dots (1.)$$

Mr. Neville has shown, that if it is necessary that the cross-section of a channel should be bounded by straight lines, the form of least resistance, for given directions of those lines, is one in which all the straight lines are tangents to one semicircle, having for its radius the greatest depth of water in the channel; and in such forms, the hydraulic mean depth is still one-half of the radius

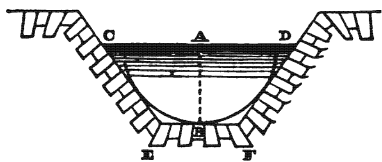

Fig. 44.

of the semicircle, as in equation 1. For example, let it be required to draw the best figure for a channel with a flat bottom, and sides of a given slope. In fig. 44, let C A D represent the surface of the water, and $\overline{AB} = r$ its greatest depth. With the radius \overline{AB} describe a semicircle; draw a horizontal tangent to it, \overline{EBF} , for the bottom of the

channel, and a pair of tangents EC, FD, at the given inclination, for the sides. The border is $b = \overline{CEFD}$, and the area $A = b r \div r$. In such channels, the length of each of the slopes, \overline{CE} , \overline{FD} , is equal to the half-breadth \overline{CA} .

If the channel is to be built of brick, stone, or concrete, with cement or hydraulic mortar, either the semicircular form may be employed, or a rectangular form with a flat bottom and vertical sides, the breadth being double of the depth; or a *semi-hexagon*, consisting of a flat bottom whose breadth is equal to half the breadth at the surface of the water, and a pair of slopes inclined at 60° to the horizon. The second and third are figures which fall under Mr. Neville's rule; and the third has the least resistance of all figures whose borders consist of a bottom and two slopes.

If the channel is to be made of clay with rubble stone pitching, Mr. Neville's form is to be used, with slopes of at least 1½ to one.

The figure having been selected, it is obvious that the sectional areas of all similar figures will be proportional to the squares of their hydraulic mean depths; so that we may put

$$A = n m^2; \dots\dots\dots(2.)$$

n being a factor depending on the figure.

For a semicircle,

$$n = 2 \pi = 6.2832; \dots\dots\dots(3.)$$

For a half-square,

$$n = 8; \dots\dots\dots(4.)$$

For a half-hexagon,

$$n = 4 \sqrt{3} = 6.928; \dots\dots\dots(5.)$$

For Mr. Neville's figure, with a flat bottom, and slopes inclined at any angle θ to the horizon,

$$n = 4 \left(\operatorname{cosec} \theta + \tan \frac{\theta}{2} \right) \dots\dots\dots(6.)$$

The velocity of flow is

$$v = Q \div n m^2 \dots\dots\dots(7.)$$

Making, therefore, the proper substitutions in equation 17 of Article 99, we find

$$i = \frac{f}{m} \cdot \frac{Q^2}{2 g n^2 m^4} = \frac{f Q^2}{2 g n^2 m^5}; \dots\dots\dots(8.)$$

from which is deduced the following value of the *required hydraulic mean depth* :—

$$m = \left(\frac{f Q^2}{2 g n^2 i} \right)^{\frac{1}{5}} \dots\dots\dots(9.)$$

The value of f is given in Article 99, equation 15, and contains a small term varying inversely as the velocity. Assuming as an *approximate average* value

$$f = 0.007565, \dots \dots \dots (10.)$$

we find,

$$m = \left(\frac{Q^2}{8512 n^2 i} \right)^{\frac{1}{5}}; \dots \dots \dots (11.)$$

and having computed the required hydraulic mean depth, all the other dimensions of the channel can be deduced from it.

The head race should have a waste weir and sluice of its own, near its lower end, to prevent the risk of the water overflowing its banks; and if it is of great length, it may be advisable to have several waste weirs along its course.

140 A. **Table of Squares and Fifth Powers.**—The preceding formula is exactly similar to equation 11 of Article 108, except that in the present case the diameter of the pipe d is replaced by the hydraulic mean depth of the channel m , and the multiplier 0.23 by $(8512 n^2)^{-\frac{1}{5}}$.

Considering that for pipes and channels of similar figures, the fifth powers of the corresponding transverse dimensions are proportional to the squares of the volumes of flow, it appears that a table of squares and fifth powers, such as is here given, is useful in comparing pipes and channels of different dimensions. Suppose, for example, that for two similar channels of the same declivity, the volumes of flow are in a given proportion, look, in the column of fifth powers, for two numbers as nearly as possible in that proportion; and opposite them, in the column of squares, will be found two numbers nearly proportional to the corresponding transverse dimensions of the channels.

141. The **Regulating Sluice** should be placed as close as possible to the wheel. It delivers the supply of water either above its upper edge, like a weir or notch board, or between its lower edge and the lower edge or *sill* of the opening in which it slides.

The delivery above the sluice is the best suited for wheels on which the water acts chiefly by its weight. The discharge in cubic feet per second for a given depression of the upper edge of the sluice below the surface of the water in the head race may be calculated by the formulæ of Article 94, Division III.

The delivery between the lower edge of the sluice and the sill is the best suited to wheels on which the water acts chiefly by impulse. In both these cases, the co-efficient of discharge for a vertical sluice may be taken on an average as

$$c = 0.7; \dots \dots \dots (1.)$$

	Square.	Fifth Power.		Square.	Fifth Power.
10	1 00	1 00000	55	30 25	5032 84375
11	1 21	1 61051	56	31 36	5507 31776
12	1 44	2 48832	57	32 49	6016 92057
13	1 69	3 71293	58	33 64	6563 56768
14	1 96	5 37824	59	34 81	7149 24299
15	2 25	7 59375	60	36 00	7776 00000
16	2 56	10 48576	61	37 21	8445 96301
17	2 89	14 19857	62	38 44	9161 32832
18	3 24	18 89568	63	39 69	9924 36543
19	3 61	24 76099	64	40 96	10737 41824
20	4 00	32 00000	65	42 25	11602 90625
21	4 41	40 84101	66	43 56	12523 32576
22	4 84	51 53632	67	44 89	13501 25107
23	5 29	64 36343	68	46 24	14539 33568
24	5 76	79 62624	69	47 61	15640 31349
25	6 25	97 65625	70	49 00	16807 00000
26	6 76	118 81376	71	50 41	18042 29351
27	7 29	143 48907	72	51 84	19349 17632
28	7 84	172 10368	73	53 29	20730 71593
29	8 41	205 11149	74	54 76	22190 06624
30	9 00	243 00000	75	56 25	23730 46875
31	9 61	286 29151	76	57 76	25355 25376
32	10 24	335 54432	77	59 29	27067 84157
33	10 89	391 35393	78	60 84	28871 74368
34	11 56	454 35424	79	62 41	30770 56399
35	12 25	525 21875	80	64 00	32768 00000
36	12 96	604 66176	81	65 61	34867 84401
37	13 69	693 43957	82	67 24	37073 98439
38	14 44	792 35168	83	68 89	39390 40643
39	15 21	902 24199	84	70 56	41821 19424
40	16 00	1024 00000	85	72 25	44370 53125
41	16 81	1158 56201	86	73 96	47042 70176
42	17 64	1306 91232	87	75 69	49842 09207
43	18 49	1470 08443	88	77 44	52773 19168
44	19 36	1649 16224	89	79 21	55840 59449
45	20 25	1845 28125	90	81 00	59049 00000
46	21 16	2059 62976	91	82 81	62403 21451
47	22 09	2293 45007	92	84 64	65908 15232
48	23 04	2548 03968	93	86 49	69568 83693
49	24 01	2824 75249	94	88 36	73390 40224
50	25 00	3125 00000	95	90 25	77378 09375
51	26 01	3450 25251	96	92 16	81537 26976
52	27 04	3802 04032	97	94 09	85873 40257
53	28 09	4181 95493	98	96 04	90392 07968
54	29 16	4591 65024	99	98 01	95099 00499

because the contraction is *partial*; but the sluice is very often inclined; and then, for an inclination of 60° to the horizon, or thereabouts,

$$c = 0.74; \dots\dots\dots (2.)$$

and for an inclination of 45° , or less,

$$c = 0.8 \dots\dots\dots (3.)$$

The regulating sluice is moved by mechanism suitable for adjusting its position with nicety, such as a rack and pinion, or a screw.

142. **Water Wheel Governors** are all much alike in principle,

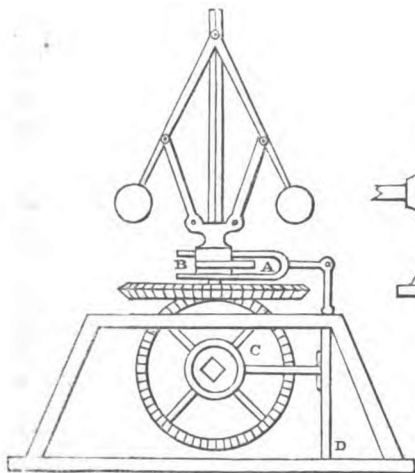

Fig. 45.

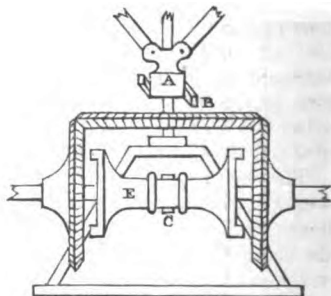

Fig. 46.

though varied in details. The single example here chosen to illustrate them is by Mr. Hewes.

Figs. 45 and 46 are elevations of this apparatus viewed along and across a horizontal shaft, to be afterwards mentioned; fig. 47 is a horizontal section, below the level of the pair of revolving pendulums, which are shown in the elevation as forming the uppermost part of the apparatus, and are carried by a vertical spindle, driven by the water wheel.

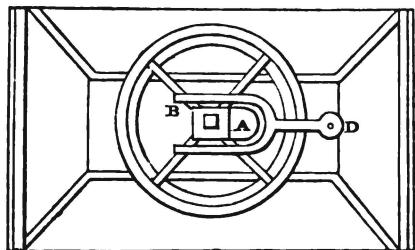

Fig. 47.

As to revolving pendulums in general, see Articles 19, 55.

From the rods of the revolving pendulums two links suspend a square slider, which rotates, rises and falls with the balls of the pendulum, and from which projects a cam A.

From a vertical shaft D, there projects a horizontal fork B, whose prongs are at opposite sides of the pendulum spindle. The end of the right-hand prong is above, and the left-hand prong below, the level of the cam A, when it is at the elevation corresponding to the proper speed of the wheel, so that the cam revolves without touching either prong; but the slider, immediately above and below the cam, is of such dimensions, as to bring the fork to its middle position if it has deviated from it.

[In many water wheel governors, the fork corresponding to B is four-pronged, having one pair of prongs at the middle elevation of the cam, and wide enough apart to allow the cam to revolve freely between them when the fork is in its middle position. The other two prongs are closer to the spindle, and one is above, and the other below, the middle elevation of the cam, like the two prongs of the fork shown in the figures.]

The lower end of the pendulum-spindle carries a horizontal bevel wheel, which drives two vertical bevel wheels, turning loosely on a horizontal shaft, which by suitable mechanism is connected with the regulating sluice. The vertical bevel wheels obviously rotate in opposite directions.

E is a double clutch, which in its middle position is free of both the vertical bevel wheels; but which, by being moved to one side or to the other, can be made to lay hold of either of those wheels, so as to make that wheel communicate its rotation to the horizontal shaft.

C is a second fork, projecting from the vertical shaft D, and clasping the clutch, so as to regulate its position.

When the water wheel goes faster than its proper speed, the pendulums rise, lifting along with them the revolving cam A, which strikes the upper and right-hand prong of the fork B, and drives it towards the right, together with the second fork C, which shifts the clutch so as to lay hold of one of the vertical bevel wheels, and thus causes the horizontal shaft to rotate in such a direction as to close by degrees the regulating sluice; and this closing goes on until the water wheel has resumed its proper speed, when the pendulums fall to their middle position, and lower the cam so that it no longer strikes either prong of the fork. The clutch is then disengaged from both wheels, and the sluice remains in the position to which it has been brought.

When the water wheel goes slower than its proper speed the pendulums sink, lowering at the same time the cam A, which strikes the lower and left-hand prong of the fork B, and drives it

towards the left, together with the second fork C, which shifts the clutch so as to make it lay hold of the other vertical bevel wheel, and thus causes the horizontal shaft to rotate in such a direction as to open by degrees the regulating sluice; and this opening goes on until the water wheel has resumed its proper speed, when the pendulums rise to their middle position, and lift the cam A so that it no longer strikes either prong of the fork. The clutch is then disengaged from both wheels, and the sluice remains in the position to which it has been brought.

143. **A General Description of Vertical Water Wheels** will now be given, and illustrated by figures of those forms of the different classes of wheels which were most common before the latest improvements, these being reserved for the more detailed descriptions in the ensuing sections.

Vertical water wheels may be classed as follows:—I. *Overshot wheels* and *breast wheels*, being vertical wheels, on which the water acts partly by its weight, or by potential energy, and partly by its impulse, or by actual energy. II. *Undershot wheels*, being vertical wheels, on which the water acts by its impulse. The following are the essential parts common to all vertical water wheels:—1. The *axis* or shaft, and its gudgeons or journals. 2. The radiating parts on which the water acts; which in overshot and breast wheels are *buckets* or cells; in undershot wheels, *floats* or *vanes*. 3. The *arms* or *spokes* and other framework by which the buckets or floats are connected with the shaft. The channel or chamber in which the wheel works is called the *wheel race* or *wheel trough*. Water wheels are protected from frost, and from other causes of stoppage and injury, by being enclosed in a *wheel house*.

I. *Overshot and Breast Wheels*.—The water is supplied to this class of wheels at or below the summit, and acts wholly, or chiefly, by its weight. The periphery of an overshot wheel consists of the *sole plate*, a cylindrical drum, and the *crowns*, being two thin vertical rings, connected with the shaft by *arms* and *braces*, and having the space between them divided into cells by curved or angular trough-shaped partitions called *buckets*. The water pours from the pentstock through the regulating sluice, sometimes guided by a spout, into the openings at the outer edges of the circle of buckets, filling them in succession. Formerly the buckets used to be closed at their inner sides, which are parts of the sole plate, but now they are made with openings for the escape and re-entrance of air. While the buckets are descending, part of the water overflows and escapes, and this is a cause of waste of energy: as each bucket arrives at the lowest point of its revolution, it discharges all its water into the tail race, and ascends empty. A breast wheel differs from an overshot wheel chiefly in having

the water poured into the buckets at a somewhat lower elevation as compared with the summit of the wheel, and in being provided with a casing or trough, called a *breast*, of the form of an arc of a cylinder, extending from the regulating sluice to the commencement of the tail race, and nearly fitting the periphery of the wheel, which revolves within it. The effect of the breast is to prevent the overflow of water from the lips of the buckets until they are over the tail race. The usual velocity of the periphery of overshot and high breast wheels is from three to six feet per second; and their available efficiency, when well designed and constructed, is from 0.7 to 0.8. The diameter of an overshot wheel must be little less than the height of the fall of water, and that of a high breast wheel somewhat greater; and they are, consequently, sometimes of enormous size. A few exist exceeding seventy feet in diameter. Wheels of this class are the best where there are large supplies of water and falls that are not too low.

II. *Undershot and Low Breast Wheels.*—Wheels of this class are driven chiefly by the impulse of water, discharged from an opening at the bottom of the reservoir with the velocity produced by the fall, against *floats* or vanes. Every such wheel has a certain *velocity of maximum efficiency*, being the velocity of the wheel which gives the least possible velocity to the discharged water, and bearing a ratio to the supply-velocity of the water which depends on the form of the floats, but does not in any case differ much from $\frac{1}{2}$. In undershot wheels of the old construction, the floats are flat boards in the direction of radii of the wheel, and the maximum theoretical efficiency is $\frac{1}{2}$. The available efficiency is much less, seldom exceeding $\frac{1}{3}$. An undershot wheel, provided with a *breast* or casing extending as before described from the sluice to the commencement of the tail race, becomes a low breast wheel, in which the water acts partly by weight, though chiefly by impulse. This class of wheels was much improved by Poncelet, who curved the floats with a concavity backwards, adjusting their position and figure so that the water should be supplied to them without shock, and should drop from them into the tail race without any horizontal velocity. The maximum theoretical efficiency of such wheels is as great as that of overshot wheels, but their available efficiency has not been found to exceed 0.6. They are well adapted to low falls with large supplies of water.

Fig. 48 is a general view of an overshot wheel of the old construction. A, spout; B, shaft and gudgeons; C, spokes; D, crowns, one having a toothed ring, for driving a pinion, and so giving motion to machinery; E, sole plate; F, buckets; G, tail race, in which the water runs in the direction opposite to that of the motion of the adjoining part of the wheel.

Figs. 49, 50, and 51, are vertical sections of part of the rim of an overshot wheel; figs. 49 and 50 showing wooden buckets, and fig.

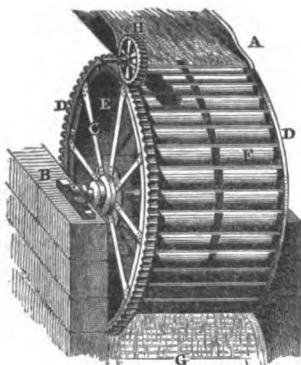

Fig. 48.

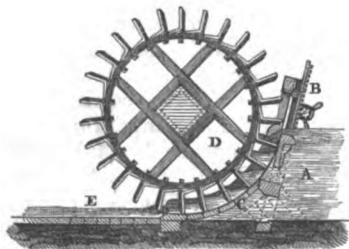

Fig. 52.

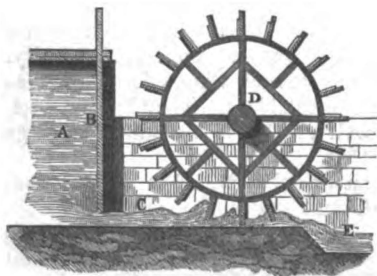

Fig. 53.



Fig. 49. Fig. 50. Fig. 51.

51 iron buckets. In each of these figures, D denotes the crown, E the sole plate, F the buckets.

Two methods were formerly employed of preventing the air in the buckets from impeding the entrance of the water; one was to make a few small holes in the sole plate, and the other, to make the wheel broader than the spout, so that the air could escape at the ends of the buckets while the water entered in the middle. The method now used will be described in the sequel.

Fig. 52 is a wooden breast wheel of the old construction, with flat floats. A, reservoir; B, sluice, worked by a rack and pinion; C, breast and wheel trough; D, wheel; E, tail race, in which the water moves along with the wheel. The water acts on this wheel partly by impulse and partly by weight.

Fig. 53 is an undershot wheel of the old construction. A, reservoir; B, sluice; C, wheel trough; D, wheel; E, tail race, in which the water

moves along with the wheel. The water acts on this wheel wholly by impulse.

144. **Impulse of Water on Vanes** (partly extracted from *A. M.*, 648, 649).—The action of water “by impulse” against a solid

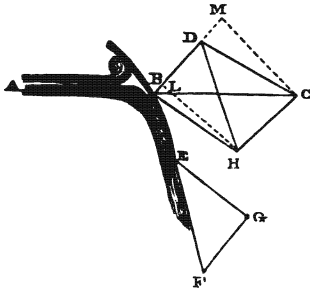

Fig. 54.

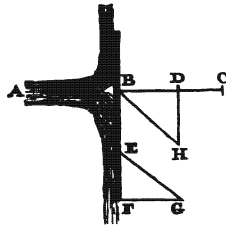

Fig. 55.



Fig. 56.

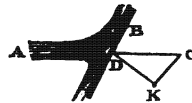

Fig. 57.

surface, is that pressure which is exerted by the water against the surface in consequence of the velocity and direction of the motion of the water being changed by contact with the surface.

The direction and amount of the pressure exerted by a jet or stream of water against the solid surface are determined by the following principles, which are the expression of the *second law of motion* (already cited in Articles 14, 29, 30), as applied to this case :—

I. The direction of that pressure is opposite to the direction of the change produced in the motion of the stream during its contact with the surface.

II. The magnitude of that pressure bears to the weight of water flowing along the stream in a second, the same ratio which the velocity per second of the change in the motion of the stream bears to the velocity generated by gravity in a second (viz., $g = 32.2$ feet per second).

It only remains to be shown, how the direction and velocity of the change of motion of the stream are to be determined.

In what follows, the effect of friction between the stream and the vane is supposed to be insensible.

In each of the figs. 54, 55, 56, 57, A represents the stream or jet, and B the vane. Fig. 54 represents the case in which the vane guides the stream in one definite direction E F; and the solution of this case leads to, or comprehends, the solution of the others. Figs. 55 and 57 represent cases in which the vane has a plane surface, and the stream glances off it in various directions. In fig. 55 the vane is perpendicular, and in fig. 57 oblique, to the direction of the stream. Fig. 56 represents a concave cup-shaped vane, turning the stream backwards. Corresponding lines on the different figures are marked with the same letters.

A jet of fluid A, striking a smooth surface, is deflected so as to glide along the surface, and at length glances off at the edge E, in a direction tangent to the surface. As the particles of fluid in contact with the surface move along it, and the only sensible force exerted between them and the surface is perpendicular to their direction of motion, that force cannot accelerate or retard the motion of the particles, relatively to the surface, but can only deviate it.

When the surface has a motion of translation in any direction with the velocity u , let B D represent that direction and velocity, and B C the direction and original velocity v of the jet. Then D C represents the direction and velocity of the original motion of the jet relatively to the surface. Draw E F = D C tangent to the surface at E, where the jet glances off; this represents the relative velocity and direction with which the jet leaves the surface. Draw F G || and = B D, and join E G; this last line represents the direction and velocity relatively to the earth, with which the jet leaves the surface, being the resultant of E F and F G.

I. *General Problem.*—Draw $\overline{D H}$ parallel to the tangent E F, and equal to D C; then will the base $\overline{C H}$ of the isosceles triangle C D H represent the direction and velocity of the *change of motion* undergone by the jet during its contact with the vane; so that, according to the first of the principles already laid down,

H C is the *direction* of the pressure exerted by the jet against the vane;

and, according to the second of those principles, the *magnitude* of that pressure is

$$D Q \cdot \frac{\overline{H C}}{g}; \dots\dots\dots (1.)$$

when D Q is the weight of the flow of water in a second.

But the whole magnitude of that pressure is of less importance than the magnitude of that component of it which is an *effort* as respects the vane; that is, which acts along the direction B D of

the vane's motion. To find that effort, \overline{HC} in equation 1 is to be replaced by its projection on BD , viz, \overline{LM} ; HL and CM being perpendiculars let fall on BD from the two ends of HC . Therefore, let P denote the effort required; then

$$P = D Q \cdot \frac{\overline{LM}}{g} ; \dots\dots\dots (2.)$$

and the *energy per second* exerted by the jet on the vane is

$$P u = D Q \cdot \frac{\overline{LM} \cdot \overline{BD}}{g} \dots\dots\dots (3.)$$

[In fig. 55, the line corresponding to \overline{LM} is simply \overline{DC} , the difference between the velocities of the jet and vane.]

To express these principles algebraically, let

$v_1 = \overline{BC}$ denote the original velocity of the jet;

$u = \overline{BD}$, the velocity of the vane;

$\alpha = \angle DBC$, the angle between the directions of those velocities;

$\gamma = \angle MDH = \text{supplement } \angle EFG$, the angle which a tangent to the vane at the edge where the jet leaves it, makes with the direction of motion of the vane; then,

$$\overline{BM} = v_1 \cos \alpha ; \overline{DM} = v_1 \cos \alpha - u ;$$

$$\overline{DH} = \overline{DC} = \sqrt{\{v_1^2 + u^2 - 2 u v_1 \cos \alpha\}}.$$

$\overline{DL} = -\overline{DH} \cos \gamma$ (in which it is to be observed, that cosines of obtuse angles are negative); and, consequently,

$$\overline{LM} = v_1 \cos \alpha - u - \cos \gamma \cdot \sqrt{\{v_1^2 + u^2 - 2 u v_1 \cos \alpha\}} \dots (4.)$$

$$P = D Q \cdot \frac{1}{g} \left\{ \begin{array}{l} v_1 \cos \alpha - u - \cos \gamma \cdot \\ \sqrt{\{v_1^2 + u^2 - 2 u v_1 \cos \alpha\}} \end{array} \right\} \dots\dots (5.)$$

$$P u = D Q \cdot \frac{1}{g} \left\{ \begin{array}{l} u v_1 \cos \alpha - u^2 - u \cdot \cos \gamma \cdot \\ \sqrt{\{v_1^2 + u^2 - 2 u v_1 \cos \alpha\}} \end{array} \right\} \dots (6.)$$

If the final velocity of the water, $\overline{EG} = \overline{BH}$, be denoted by v_2 , its value is

$$\begin{aligned} v_2 &= \sqrt{\{ \overline{BD}^2 + \overline{DH}^2 + 2 \overline{BD} \cdot \overline{DH} \cdot \cos \gamma \}} \\ &= \sqrt{\{v_1^2 - 2 u (v_1 \cos \alpha - u) + 2 u \cdot \cos \gamma \sqrt{\{v_1^2 + u^2 - 2 u v_1 \cos \alpha\}}\}} \end{aligned} \quad (7.)$$

From which it is evident that equation 6 is equivalent to the following:—

$$P u = D Q \cdot \frac{v_1^2 - v_2^2}{2g}; \dots\dots\dots (8.)$$

that is, *the energy exerted by the water on the vane is equal to the actual energy lost by the water*, a consequence of the assumption that the friction is insensible.

The **EFFICIENCY** of the action of the jet on the vane is the ratio of the energy exerted on the vane in a second to the *actual energy* of the flow in a second; that is, its value is

$$\left. \begin{aligned} 1 - k &= \frac{P u}{D Q \cdot \frac{v_1^2}{2g}} = 1 - \frac{v_2^2}{v_1^2} = 1 - \frac{\overline{B H}^2}{\overline{B C}^2} \\ &= 2 \frac{u}{v_1} \cdot \cos \alpha - \frac{u^2}{v_1^2} - \frac{u}{v_1} \cdot \cos \gamma \cdot \sqrt{\left\{ 1 + \frac{u^2}{v_1^2} - 2 \frac{u}{v_1} \cos \alpha \right\}} \end{aligned} \right\} (9.)$$

It is obvious that there are two cases in which the efficiency is nothing; first, when the vane stands still, or $u = 0$; and, secondly, when the vane moves at such a speed that $P = 0$; that is, when

$$u \div v_1 = \cos \alpha + \sin \alpha \cotan \gamma \dots\dots\dots (10.)$$

For each particular pair of angles α and γ , there is an intermediate value of the ratio $u \div v_1$, which makes the efficiency a maximum. The determination of that ratio in the most general case involves the solution of an equation of the fourth order, and is not useful in proportion to the trouble of obtaining it. The ratio, therefore, will be determined in those particular cases only which are most useful.

II. *Case in which $\overline{H C} \parallel \overline{B D}$.*—In this case, the pressure exerted by the jet on the vane is wholly an effort, being parallel to the direction of motion of the vane. In order that it may be so, the angles $C D M$, $H D M = \gamma$, made respectively by the original and final motion of the jet *relatively to the vane*, with the direction of motion of the vane, must be equal, so that

$$\overline{D L} = \overline{D M} = v_1 \cos \alpha - u;$$

and equations 4, 5, 6, 7, and 9, become

$$\overline{L M} = 2 (v_1 \cos \alpha - u); \dots\dots\dots (11.)$$

$$P = \frac{2 D Q (v_1 \cos \alpha - u)}{g}; \dots\dots\dots (12.)$$

$$P u = \frac{2 D Q u (v_1 \cos \alpha - u)}{g}; \dots\dots\dots(13.)$$

$$v_2 = \sqrt{\{v_1^2 - 4 u (v_1 \cos \alpha - u)\}}; \dots\dots\dots(14.)$$

$$1 - k = \frac{P u}{D Q \frac{v_1^2}{2g}} = 1 - \frac{v_2^2}{v_1^2} = \frac{4 u (v_1 \cos \alpha - u)}{v_1^2} \dots\dots(15.)$$

In this it is evident, that the efficiency is nothing when u is either = 0, or = $v_1 \cos \alpha$, and that the *speed of greatest efficiency* is

$$u = \frac{v_1 \cos \alpha}{2}; \dots\dots\dots(16.)$$

for which the effort, the energy exerted per second, and the final velocity of the water, have the values

$$P = \frac{D Q v_1 \cos \alpha}{g}; \dots\dots\dots(17.)$$

$$P u = \frac{D Q v_1^2 \cos^2 \alpha}{2g}; \dots\dots\dots(18.)$$

$$v_2 = v_1 \sin \alpha; \dots\dots\dots(19.)$$

and the *greatest efficiency* itself is

$$1 - k = \cos^2 \alpha \dots\dots\dots(20.)$$

III. *Case of a Flat Vane, normal to the Jet, and moving in the same direction* (fig. 55).—In this case the water glances off from the edge of the vane in all directions; $\cos \alpha = 1$; $\cos \gamma = 0$; and equations 5, 6, 7, and 9, become

$$P = D Q \cdot \frac{v_1 - u}{g}; \dots\dots\dots(21.)$$

$$P u = D Q \cdot \frac{u (v_1 - u)}{g}; \dots\dots\dots(22.)$$

$$v_2 = \sqrt{(v_1^2 - 2 u v_1 + 2 u^2)} \dots\dots\dots(23.)$$

$$1 - k = \frac{2 u (v_1 - u)}{v_1^2} \dots\dots\dots(24.)$$

The greatest efficiency evidently takes place when

$$u = \frac{v_1}{2}; \dots\dots\dots(25.)$$

and in that case

$$P = \frac{D Q v_1}{2 g} \dots\dots\dots(26.)$$

$$P u = \frac{D Q v_1^2}{4 g}; \dots\dots\dots(27.)$$

$$v_2 = \frac{v_1}{\sqrt{2}}; \dots\dots\dots(28.)$$

$$1 - k = \frac{1}{2}; \dots\dots\dots(29.)$$

so that at least one-half of the energy of the jet is lost.

IV. *Case of a Cup Vane* (fig. 56).—Let the motion of this vane be in the same direction with that of the jet, so that $\cos \alpha = 1$; and to avoid the inconvenience of using negative quantities, let $\beta = \gamma - 90^\circ$ be the *acute angle* made by the edge of the cup, all round which the water glances off, with the axis of the cup; so that $-\cos \gamma = +\cos \beta$. Then equations 4, 5, 6, 7, and 9, become

$$\overline{L M} = (v_1 - u) (1 + \cos \beta); \dots\dots\dots(30.)$$

$$P = D Q \cdot \frac{v_1 - u}{g} \cdot (1 + \cos \beta); \dots\dots\dots(31.)$$

$$P u = D Q \cdot \frac{u (v_1 - u)}{g} (1 + \cos \beta); \dots\dots\dots(32.)$$

$$v_2 = \sqrt{\{v_1^2 - 2 u (v_1 - u) \cdot (1 + \cos \beta)\}} \dots\dots\dots(33.)$$

$$1 - k = \frac{2 u (v_1 - u) \cdot (1 + \cos \beta)}{v_1^2} \dots\dots\dots(34.)$$

The *speed* of greatest efficiency is obviously, as in case III.,

$$u = \frac{v_1}{2}; \dots\dots\dots(35.)$$

and then

$$P = D Q \cdot \frac{v_1}{2 g} \cdot (1 + \cos \beta); \dots\dots\dots(36.)$$

$$P u = D Q \cdot \frac{v_1^2}{4 g} \cdot (1 + \cos \beta); \dots\dots\dots(37.)$$

$$v_2 = v_1 \cdot \sqrt{\left(1 - \frac{1 + \cos \beta}{2}\right)}; \dots\dots\dots(38.)$$

$$1 - k = \frac{1 + \cos \beta}{2} \dots\dots\dots(39.)$$

The *form* of greatest efficiency for the vane is a hemisphere, for which $\cos \beta = 1$; and then, when the *speed* of greatest efficiency is maintained, we find

$$P = \frac{D Q v_1^2}{g}; \dots\dots\dots(40.)$$

$$P u = \frac{D Q v_1^2}{2 g}; \dots\dots\dots(41.)$$

$$v_2 = 0; \dots\dots\dots(42.)$$

$$1 - k = 1; \dots\dots\dots(43.)$$

being *perfect efficiency*.

V. *Case of a Flat Vane, oblique to the Jet* (fig. 57).—In this case, the easiest method of solution is the following :—

Let $v' = \overline{DC}$ be the velocity of the jet *relatively to the vane*, found as in the general case. Let the angle $C D K$ which it makes with a normal to the vane be denoted by θ .

Resolve $v' = C D$ into two components, viz :—

$$\left. \begin{aligned} \overline{DK} \text{ normal to the vane} &= v' \cdot \cos \theta; \\ \overline{KC} \text{ along the vane} &= v' \cdot \sin \theta; \end{aligned} \right\} \dots\dots\dots(44.)$$

Then according to the supposition that friction is insensible, $K C$ is not affected in magnitude by the vane; but \overline{DK} is entirely taken away; so that \overline{DK} , in fig. 57, corresponds to \overline{HC} in fig. 54, and represents the direction and velocity of the entire change of motion produced by the action of the vane on the water. Hence the whole pressure exerted by the water on the vane is in a direction normal to the vane, and its magnitude is

$$P' = D Q \cdot \frac{v' \cdot \cos \theta}{g} \dots\dots\dots(45.)$$

Now let u be the velocity with which the vane moves, in a direction making the angle δ with the normal to its surface; then the *effort* of the water on the vane is

$$P = P' \cos \delta = D Q \cdot \frac{v' \cos \theta \cos \delta}{g}, \dots\dots\dots(46.)$$

and the energy exerted,

$$P u = D Q \cdot \frac{u v' \cos \theta \cos \delta}{g}; \dots\dots\dots(47.)$$

which being divided by $D Q v_1^2 \div 2 g$, as in former cases, gives the efficiency.

Another mode of arriving at the same result is as follows :—

Let ζ be the angle which the original direction of the jet makes with the normal to the vane. Then

$$v' \cos \theta = v_1 \cos \zeta - u \cos \delta; \dots\dots\dots(48.)$$

from which we obtain

$$P = D Q \cdot \frac{v_1 \cos \zeta \cos \delta - u \cos^2 \delta}{g}; \dots\dots\dots(49.)$$

$$P u = D Q \cdot \frac{u v_1 \cdot \cos \zeta \cos \delta - u^2 \cos^2 \delta}{g}; \dots\dots(50.)$$

$$1 - k = 2 \frac{u}{v_1} \cdot \cos \zeta \cos \delta - 2 \frac{u^2}{v_1^2} \cdot \cos^2 \delta \dots\dots\dots(51.)$$

The speed of greatest efficiency is

$$u = \frac{v_1 \cos \zeta}{2 \cos \delta}; \dots\dots\dots(52.)$$

giving the following results :—

$$P = D Q \cdot \frac{v_1 \cos \zeta \cos \delta}{2 g}; \dots\dots\dots(53.)$$

$$P u = D Q \cdot \frac{v_1^2 \cos^2 \zeta}{4 g}; \dots\dots\dots(54.)$$

$$1 - k = \frac{\cos^2 \zeta}{2}; \dots\dots\dots(55.)$$

which is *independent of δ* .

145. **Best form of Vane to receive Jet.**—In all water wheels, whether the water acts chiefly by weight or chiefly by impulse, it is desirable, in order to reduce to as small an amount as possible the loss of energy by agitation of the water, that the jet, on first coming in contact with the vane, float, or bucket lip, should not *strike* it, but *glide* along it.

That object is attained in the following manner :—

In fig. 58, O B E is a vane, float, or bucket, moving in the

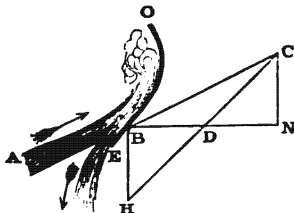

Fig. 58.

direction B D with the velocity $u = \overline{BD}$. A is a jet, moving in the direction B C with the velocity $v_1 = \overline{BC}$, and first touching the vane at and near the point B. Join \overline{DC} : then that line will represent the direction and velocity of the motion of the water *relatively to the vane*; and of what shape soever the vane may be elsewhere, its surface at and near B, where it first receives the

jet, should be parallel to D C.

PONCELET'S FLOATS.—This improvement in the form of vanes or floats was introduced by Poncelet, and applied to his undershot wheels, which will be further described in the sequel. The principle is applicable to all wheels whatsoever.

The following consequences of the principle are applicable to the case No. II. of Article 144, in which the angle $\gamma = \text{NDH}$, made by the edge of the vane where the water glances off, with the direction of motion of the vane, is supplementary to the angle which is made with that direction by the original relative motion of the jet. This condition is fulfilled in Poncelet's wheels; for the water, after running up towards O, to the vertical height due to its relative velocity \overline{DC} , returns, and glances off at the edge E near B; so that \overline{DH} , equal and opposite to \overline{DC} , represents the direction and velocity of its final motion *relatively to the vane*, and \overline{BH} the direction and velocity of that motion *relatively to the earth*. It has been shown, in the division of Article 144 just referred to, that the speed of greatest efficiency, neglecting friction, is

$$u = \frac{v_1 \cos \alpha}{2},$$

(where $\alpha = \angle \text{CBN}$). Therefore, from C let fall CN perpendicular to BN; bisect BN in D, and join DC; then to this line the vane, at and near BE, would have to be made parallel if there were no friction. But one of the effects of friction is to make the speed of greatest efficiency somewhat greater than $\frac{1}{2} v_1 \cos \alpha$; and this must be considered in designing vanes, as will be shown in the next Article.

146. Effect of Friction during Impulse.—In the two preceding Articles, the friction, during the impulse of the water on the vanes, has been supposed to be insensible. Nothing precise is known of its mode of action, and the following investigation is in a great measure conjectural; but its results show a general agreement with those of experiment.

Let it be assumed, that the friction in question causes a loss of energy per second proportional to *the height due to the velocity of the water relatively to the vane*; which velocity is

$$\overline{DC} = \sqrt{\{(v_1 \cos \alpha - u)^2 + v_1^2 \sin^2 \alpha\}}.$$

Then the loss of energy per second by friction may be represented by

$$D Q f \cdot \frac{(v_1 \cos \alpha - u)^2 + v_1^2 \sin^2 \alpha}{2 g} \dots \dots \dots (1.)$$

f being an unknown co-efficient.

Let the case under consideration still be Case II. of Article 144, illustrated in fig. 58; then referring to equation 13 of that Article for the energy exerted on the vane per second when friction is not allowed for, it appears that, after deducting loss by friction, that energy becomes

$$P u = D Q \cdot \left\{ \frac{2 u (v_1 \cos \alpha - u)}{g} - f \cdot \frac{(v_1 \cos \alpha - u)^2 + v_1^2 \sin^2 \alpha}{2g} \right\}; \dots\dots\dots(2.)$$

so that the efficiency is reduced to

$$1 - k = \frac{4 u (v_1 \cos \alpha - u)}{v_1} - \frac{f(v_1 \cos \alpha - u)^2}{v_1^2} - f \sin^2 \alpha \dots(3.)$$

From this expression it is easily found that the *speed of greatest efficiency* has the value

$$u_1 = \frac{2 + f}{4 + f} \cdot v_1 \cos \alpha; \dots\dots\dots(4.)$$

being *greater* than the speed of greatest efficiency when friction is insensible, in the proportion

$$4 + 2f : 4 + f.$$

Suppose that the speed of greatest efficiency, u_1 , for a given wheel has been found by experiment. Then the co-efficient f is given by the formula

$$f = \frac{4 u_1 - 2 v_1 \cos \alpha}{v_1 \cos \alpha - u_1}; \dots\dots\dots(5.)$$

which value having been substituted in equation 3, gives for the greatest efficiency,

$$1 - k = \frac{2 (v_1 \cos \alpha - u_1)}{v_1} - \frac{4 u_1 - 2 v_1 \cos \alpha}{v_1 \cos \alpha - u_1} \cdot \sin^2 \alpha \dots(6.)$$

To illustrate this by a numerical example: Suppose that $\cos \alpha = .99$; $\sin \alpha = .125$; and that it has been found by experiment that u_1 , instead of being $= v_1 \cos \alpha \times \frac{1}{2}$, as would be the case if there were no friction, is $v_1 \cos \alpha \times 0.6$.

Then by equation 5, $f = 1$; and by equation 6, $1 - k = 0.78$.

This result is approximately verified in practice, as will afterwards be shown; and, such being the case, it appears that, in designing float boards according to the principles of Article 145, $\overline{B D}$ should be made $= \frac{1}{10} \overline{B N}$. (See fig. 58.)

147. **Direct Action distinguished from Reaction.**—The pressure which a jet exerts against a vane, can always be distinguished into two parts, viz :—

I. The pressure arising from the changing the direct component $v_1 \cos \alpha$ of the velocity of the water into the velocity u of the vane. This, which may be called the *pressure due to direct impulse*, has *always* for its value

$$P_1 = D Q \cdot \frac{v_1 \cos \alpha - u}{g}; \dots\dots\dots(1.)$$

and is not affected by friction nor by any other cause; and the energy which it exerts per second on the vane is always

$$P_1 u = D Q \cdot \frac{u(v_1 \cos \alpha - u)}{g}, \dots\dots\dots(2.)$$

bearing to the whole actual energy of the water the proportion

$$\frac{2 u (v_1 \cos \alpha - u)}{v_1^2}; \dots\dots\dots(3.)$$

whose maximum value, viz,—

$$\frac{\cos^2 \alpha}{2}, \dots\dots\dots(4.)$$

corresponds to the speed,

$$u_1 = \frac{v_1 \cos \alpha}{2}, \dots\dots\dots(5.)$$

For a flat vane moving normally, as in fig. 55, this *direct action* is the only action by impulse of the water on the vane. It is also the only action by impulse when water enters a bucket and does not immediately glance out again, but continues to move along with the bucket.

II. The term *reaction* is applied to the additional action depending on the direction and velocity with which the water glances off from the vane. It is this which is diminished by the friction between the water and the vane, or amongst the particles of water which act on the vane.

Still referring to the case so often supposed, in which the water glances off at the same obliquity with which it first glided on to the vane (Article 144, Case II.), it appears, from equations 12, 13, and 15 of that Article, that if friction were insensible, the pressure, energy, and efficiency due to reaction would be simply equal to those due to the direct action, so that its effect would be to double

each of these quantities; and it appears further, from Article 146, equations 2 and 3, that the pressure, energy, and efficiency due to reaction, when friction is considered, are—

$$P_2 = D Q \left\{ \frac{v_1 \cos \alpha - u}{g} - f \frac{(v_1 \cos \alpha - u)^2 + v_1 \sin^2 \alpha}{2 g u} \right\} \quad (6.)$$

$$P_2 u = D Q \left\{ \frac{u (v_1 \cos \alpha - u)}{g} - f \frac{(v_1 \cos \alpha - u)^2 + v_1^2 \sin^2 \alpha}{2 g} \right\} \quad (7.)$$

Additional efficiency—

$$= \frac{2u(v_1 \cos \alpha - u)}{v_1^2} - f \frac{(v_1 \cos \alpha - u)^2}{v_1^2} - f \sin^2 \alpha \dots \dots \dots (8.)$$

The value of f , in the case of Poncelet's vanes, for which α is a small angle, appears to be nearly = 1. It is not, however, to be taken for granted that it has the same value for vanes of other forms. It is probable, on the contrary, that f depends in some way on the angle α , becoming smaller as α approaches a right angle, and also that it depends on the figures of the vanes; but experimental data are wanting to determine the law of such dependence.

148. **Efficiency of Vertical Water Wheels in General.**—As respects the laws of their efficiency, the vertical water wheels now in use belong to two classes, viz.,—*Weight and impulse wheels*, comprising overshot and breast wheels; and *impulse wheels*, being undershot wheels.

I. *Weight and Impulse Wheels.*—Let H be the total head, and

$$H_1 = (1 - k) H, \dots \dots \dots (1.)$$

the available head at the wheel, as reduced for losses of head, according to the principles of Article 99. This available head is to be distinguished into two parts, as follows:—

$$H_1 = h + \frac{v_1^2}{2g}; \dots \dots \dots (2.)$$

$\frac{v_1^2}{2g}$ being that portion of the head which is employed in giving the water the velocity with which it is delivered to the wheel, and h the height through which the water acts directly on the wheel by its weight.

Let u be the velocity of the circumference of the wheel. Then the total energy of the available fall per second is composed of that due to action by weight, $D Q h$, and that due to *direct action* by impulse,

$$D Q \cdot \frac{u (v_1 \cos \alpha - u)}{g};$$

and of that energy a certain fraction, which may be denoted by k'' , is lost through leakage or escape of water, and various resistances which can only be ascertained empirically; so that the EFFECTIVE POWER of the wheel is

$$R_1 u = (1 - k'') P u = (1 - k'') D Q \left\{ h + \frac{u (v_1 \cos \alpha - u)}{g} \right\} \quad (3.)$$

and its effective load, reduced to its circumference,

$$R_1 = (1 - k'') P = (1 - k'') D Q \left\{ \frac{h}{u} + \frac{u (v_1 \cos \alpha - u)}{g} \right\} \dots(4.)$$

The value of $1 - k''$, according to experiments on many water wheels made and recorded by Poncelet and General Morin, ranges from .74 to .82, and is on an average

$$(1 - k'') = .78 \text{ nearly} \dots\dots\dots(5.)$$

The EFFICIENCY of the wheel is

$$1 - k'' = (1 - k'') \frac{h + \frac{u (v_1 \cos \alpha - u)}{g}}{h + \frac{v_1^2}{2g}} \dots\dots\dots(6.)$$

It ranges from about .66 to .8 nearly.

The surface-velocity u of the wheel is fixed by considerations of practical convenience. It was formerly limited to 3 feet per second, but is now generally 6 feet per second, or thereabouts.

The velocity of supply v_1 , corresponding to the greatest efficiency for a given value of u , is

$$v_1 = \frac{2u}{\cos \alpha}; \dots\dots\dots(7.)$$

and the corresponding greatest efficiency of the wheel,

$$1 - k'' = (1 - k'') \frac{h + \frac{v_1^2}{4g}}{h + \frac{v_1^2}{2g}} = (1 - k'') \frac{h + \frac{u^2}{g}}{h + \frac{2u^2}{g}} \dots\dots\dots(8.)$$

II. *Impulse wheels* are to be distinguished into those without and those with reaction. The old *flat-floated undershot wheel*, shown in fig. 53, is an example of an impulse wheel without reaction. The formulæ applicable to it are obtained from those just given, simply by making $h = 0$; but the value of $1 - k''$ for it is only about .66 or .7, so that its greatest efficiency is from .33 to .35.

The improved undershot wheel, or "*Poncelet wheel*," is an example of an impulse wheel with reaction. The principle upon which the form of its vanes depends has been given in Article 145, and the formulæ for its load, its work per second, and the efficiency of the action of the water upon it, in Article 146, supposing $k'' = 0$. Taking, as in Article 146, the co-efficient of friction $f = 1$, and multiplying by $1 - k''$ to allow for leakage, &c., we find, for the **EFFEC-TIVE LOAD, POWER, and EFFICIENCY**, the following formulæ:—

$$R_1 = D Q \cdot \frac{1 - k''}{2 g u} \cdot \left\{ (v_1 \cos \alpha - u) \cdot (5 u - v_1 \cos \alpha) - v_1^2 \cdot \sin \alpha \right\}$$

$$= D Q \cdot \frac{1 - k''}{2 g u} \left(6 u v_1 \cos \alpha - 5 u^2 - v_1^2 \right) \dots\dots\dots(9.)$$

$$R_1 u = D Q \cdot \frac{1 - k''}{2 g} \left(6 u v_1 \cos \alpha - 5 u^2 - v_1^2 \right) \dots\dots(10.)$$

$$1 - k'' = \frac{R_1 u}{D Q \frac{v_1^2}{2 g}} = (1 - k'') \left(6 \frac{u}{v_1} \cos \alpha - 5 \frac{u^2}{v_1^2} - 1 \right) \dots\dots(11.)$$

The value of $1 - k''$, by the experiments of Poncelet and General Morin, has been found to be nearly the same as for overshot and breast wheels;—that is, it ranges from about .75 to .8, and is on an average about—

$$1 - k'' = .78 \dots\dots\dots(12.)$$

The *speed of greatest efficiency* is, as stated in Article 146, about—

$$u_1 = .6 v_1 \cos \alpha ; \dots\dots \dots(13.)$$

and then equations 9, 10, and 11, become—

$$R_1 = (1 - k'') D Q \frac{(v_1 1.8 \cos^2 \alpha - 1)}{2 g \cdot 0.6 \cos \alpha} ; \dots\dots \dots(14.)$$

$$R_1 u_1 = (1 - k'') D Q \frac{v_1^2}{2 g} \cdot (1.8 \cos^2 \alpha - 1) ; \dots\dots(15.)$$

$$1 - k'' = \frac{R_1 u_1}{D Q \frac{v_1^2}{2 g}} = (1 - k'') \cdot (1.8 \cos^2 \alpha - 1) \dots\dots(16.)$$

Taking, as in the example at the end of Article 146, $\cos^2 \alpha = .99$, and $1 - k'' = .78$, we find for the greatest efficiency:—

$$\left. \begin{array}{l}
 \cdot 78 \times \cdot 78 = \cdot 608; \\
 \text{If } 1 - k'' = \cdot 75, \text{ we have—} \\
 \cdot 75 \times \cdot 78 = \cdot 585; \\
 \text{and if } 1 - k'' = \cdot 8, \text{—} \\
 \cdot 8 \times \cdot 78 = \cdot 624.
 \end{array} \right\} \dots\dots\dots(17.)$$

When a water wheel works “*drowned*,”—that is, when the tail race is flooded, so as to immerse the lower part of the wheel, the factor $1 - k''$ is reduced to about 0.6; so that *the efficiency of a drowned wheel is about three-quarters of that of a wheel not drowned.*

149. **Choice of a Class of Wheel.**—Taking the efficiency of that part of the fall which acts by weight on a weight-and-impulse wheel at 0.8, and of that part which acts by impulse at 0.4, and the efficiency of an impulse wheel at 0.6, it is evident that the weight-and-impulse wheel is $\left\{ \begin{array}{l} \text{less} \\ \text{more} \end{array} \right\}$ efficient than the impulse wheel, according as the portion of the fall of the former which acts by impulse is $\left\{ \begin{array}{l} \text{more} \\ \text{less} \end{array} \right\}$ than one-half. In a weight-and-impulse wheel, also, the speed of the wheel should be about half of that of the water when supplied; that is, should be due to about one-quarter of that part of the fall which acts by impulse. Therefore the weight and impulse wheel is $\left\{ \begin{array}{l} \text{less} \\ \text{more} \end{array} \right\}$ efficient than the impulse wheel, according as the height due to the surface velocity of the wheel is $\left\{ \begin{array}{l} \text{more} \\ \text{less} \end{array} \right\}$ than *one-eighth* of the whole fall at the wheel.

It is advisable that the surface velocity of a water wheel should not be less than 6 feet per second. Eight times the height due to this velocity is about $4\frac{1}{2}$ feet; therefore for all falls not exceeding this, the impulse wheel is certainly the best; and the greater the required surface velocity, the higher is the limit of fall up to which the impulse wheel is superior.

The rule now laid down is of course only to be followed when there is no good reason for deviating from it.

SECTION 2.—*Of Overshot and Breast Wheels.*

150. **Overshot and Breast Wheels distinguished.**—In order that a wheel may be a breast wheel, it must be provided with the “breast” or circular trough mentioned in Article 143, for diminishing the spilling of water from the buckets. Although, therefore, the term “overshot wheel” was originally employed to designate those

wheels only in which the penstock is above the level of the top of the wheel, so as to shoot the water over the wheel, it is desirable that it should now be extended to every bucket wheel which receives the water at a high part of its circumference, and is not provided with a breast.

The necessity for a breast depends on the form and dimensions of the buckets; and its presence or absence does not affect the principles of the action of the wheel.

151. **Description of a Breast Wheel.**—The following description of a breast wheel, which may serve as a type of the entire class of overshot and breast wheels, is extracted from a paper by Mr. Fairbairn.

Fig. 59 is a sectional plan of the wheel, on a scale of about $\frac{1}{11}$ th of the real dimensions. Fig. 60 is a vertical section perpendicular to the axis of the wheel, on a scale of $\frac{1}{11}$ th, and fig. 61 is an enlarged vertical section of some of the buckets and part of the sole plate. The wheel shown is 50 feet in diameter, the greatest available fall being 48 feet.

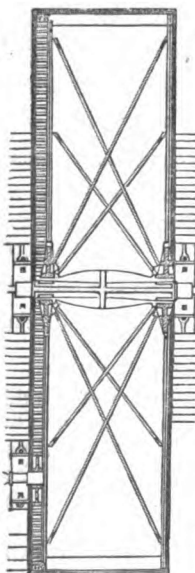

Fig. 59.

The shrouding of the wheel is *suspended* from the shaft by means of the arms, which are slender rods of wrought iron, in this case from $1\frac{1}{2}$ inch to 2 inches in diameter. The weight of the wheel exclusive of the water in the buckets, *hangs* from the shaft by those arms which point obliquely or directly downwards at the time. The inner ends of the arms are inserted into sockets in a cast iron nave or boss, and are fixed and pulled tight by means of cotters or wedges. Some of the arms, marked *a*, are perpendicular to the shaft, and these support the greater part of the weight; the other arms, marked *b*, run diagonally, and serve to give stiffness.

The weight of the water in the buckets is borne by the pinion which transmits motion to the machinery, being driven in inside gearing by the cogged ring B. In the present example the pitch of the cogs is $3\frac{1}{4}$ inches, and their breadth 15 inches. This improvement of using tension rods instead of stiff spokes, and of placing the pinion so as to support the weight of the water, and relieve the wheel shaft of all load except the weight of the wheel, is ascribed to Mr. Hewes. It has greatly diminished the weight, cost, and friction of large water wheels.

A is the shuttle or regulating sluice, which, as described in Article 141, is a moveable overfall delivering water over its upper edge,

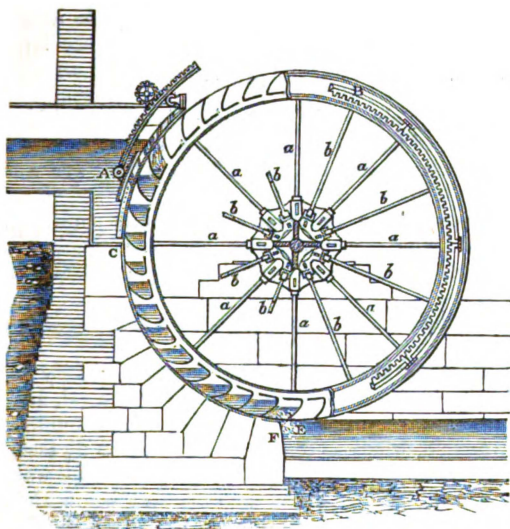

Fig. 60.

and moved by means of a rack and pinion, whose motions are controlled by the governor. The figure of the sluice is that of a portion of a cylinder concentric with the wheel; and so also is the figure of the front of the penstock. The water is delivered into the buckets between a set of *guide blades*, like the bars of a Venetian blind, which are so placed as to cause the stream to glide into the buckets without striking them.

CF is the breast, to prevent the spilling of water from the buckets. Its figure is part of a cylinder concentric with the wheel.

The breast, front of the penstock, and edges of the guide blades, are all situated in one cylindrical surface, as close to the circumference of wheel as is practicable without the risk of actual contact. About 0.4 inch of clearance is sufficient for that purpose.

At the point F, 10 inches back from a vertical line let fall from the axis, the breast terminates with a sudden drop into the tail race E. The depth, from the lower edge of the breast to the bottom of the tail race, is about two feet. This allows the buckets to clear themselves rapidly of water before beginning to ascend, and lets the tail water escape easily, without too much loss of head.

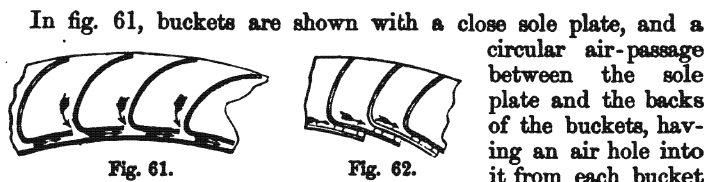

Fig. 61.

Fig. 62.

In fig. 61, buckets are shown with a close sole plate, and a circular air-passage between the sole plate and the backs of the buckets, having an air hole into it from each bucket for the discharge of air, while the bucket is filling with water, and the re-admission of air while the bucket is discharging its water. This construction is suitable for wheels which are liable to be drowned by the flooding of the tail race.

Another construction of vertical bucket is shown in fig. 62; the sole plate being dispensed with, and each bucket having an air-passage behind the bucket next above, opening into the interior of the wheel.

The present mode of ventilating buckets was introduced by Mr. Fairbairn.

152. **Diameter of Wheel.**—The best surface velocity for an overshot or breast wheel being about 6 feet per second, and the best velocity for the water supplied to it being about double of that, or 12 feet per second, which is due to a fall of about $2\frac{1}{4}$ feet, it follows that the summit of the wheel, if it is to receive the water exactly on the top, should not be more than $2\frac{1}{4}$ feet below the top-water level in the penstock. The bottom of the wheel should just clear the water in the tail race. Therefore the diameter of the wheel should *not be less than*

$$\text{The available fall—}2\frac{1}{4}\text{ feet;..... (1)}$$

and this applies to overshot wheels not ventilated.

But in order that the water may not escape through the air-passages of wheels with ventilated buckets, it is advisable that the water should be fed to the wheel at about 30° below the summit; that is to say, at a depth of about .933, or $1 \div 1.072$ of the diameter below the summit. Therefore, for such wheels, it is advisable to make *the diameter not less than*

$$1.072 \times (\text{available fall—}2\frac{1}{4}\text{ feet);..... (2)}$$

and this rule will answer when the level of the water in the penstock is *not subject to the fluctuations of more than about a foot.*

When the level of the water in the penstock is subject to greater fluctuations than this, it is desirable, in order to facilitate the adjustment of the position of the regulating sluice to those fluctuations, that the wheel should receive the water at a place where its

circumference is more nearly vertical; that is, at from 60° to 90° below the summit; so that the diameter should be

from $1\frac{1}{2}$ to $2 \times$ (available fall— $2\frac{1}{4}$ feet);(3.)

These rules are not given to be implicitly followed, but only to guide the engineer when there are no other circumstances to fix his choice of a diameter for the wheel.

153. **Pinion and Cogged Ring.**—The position of the pinion should be such, that the *pitch-point*, where its teeth are driven by those of the cogged ring, may be in the same vertical plane parallel to the axis, with the centre of gravity of the mass of water contained in the buckets.

The distance of the centre of gravity of a circular arc from the centre of the circle is given by the formula,

$$\frac{\text{Radius} \times \text{chord}}{\text{length of arc}};$$

and if this be applied to an arc traversing the full buckets, midway between the sole plate and the outer circumference of the wheel, it will give the position of the centre of gravity of the descending water very nearly.

It would be desirable that there should be a pair of cogged rings, one at each side of the wheel, driving a pair of pinions, in order to relieve the shaft of all pressure arising from the weight of the water; were it not that it has been found impossible in practice to obtain such exact fitting of the two rings and two pinions as to insure perfect equality of pressure and smoothness of motion.

154. **Strength of Gudgeons.**—The gudgeons, or ends of the wheel shaft on which it turns, have each to bear, when the wheel is unloaded and at rest, one-half of the weight of the wheel. When the wheel is loaded and in motion, the gudgeon nearest the cogged ring has to bear half the weight of the wheel less about half the weight of the water, and the gudgeon farthest from the cogged ring, half the weight of the wheel added to about half the weight of the water.

Let L denote the greatest actual load on a given gudgeon in pounds; then if its length is from five-sixths of its diameter to about equal to its diameter, its proper diameter in inches is about

$$d = \frac{\sqrt{L}}{30}.$$

155. **Strength of Arms.**—The weight is supported by the several arms which point directly or obliquely downwards, very nearly in

the proportion of the squares of the cosines of their inclinations to the vertical.

Let i , then, denote the inclination of any one arm to the vertical at a given instant, and

$$\Sigma \cdot \cos^2 i$$

the sum of the squares of the cosines of the inclinations to the vertical of the several arms which point downwards at the given instant. Also, let W be the total weight to be supported. Then

$$T = \frac{W}{\Sigma \cdot \cos^2 i} \dots \dots \dots (1.)$$

is the greatest tension on any radial arm, at the instant when it comes in its turn to point vertically downwards; and allowing 10,000 lbs. on the square inch as a safe working tension on wrought iron bars,

$$\frac{T}{10,000} \dots \dots \dots (2.)$$

is the proper sectional area for each radial arm, in square inches.

Let i' denote the least inclination to the vertical of each of the oblique arms; then the proper sectional area for each of them is

$$\frac{T \cos^2 i'}{10,000} \dots \dots \dots (3.)$$

156. Speed and Dimensions of Shrouding.—The least surface velocity for overshot and breast wheels is about 6 feet per second. Deviations from that velocity may be made for particular purposes; but it is seldom desirable to go below $4\frac{1}{2}$ feet, or above 8 feet per second. The *depth* of the shrouding or crowns between which the buckets are contained, ranges from 1 foot to $1\frac{3}{4}$ foot, its most usual value being about $1\frac{1}{4}$ foot. Let this be denoted by b . It is also the extreme *breadth* of each bucket, measured in the direction of a radius of the wheel.

Let l be the *clear breadth* between the crowns, being also the *clear length* of each bucket.

Let r be the outside radius of the wheel; u , as before, its surface velocity.

In order to avoid as far as possible the waste of water by spilling from the buckets, it is considered that only about two-thirds of the space between the crowns, on the loaded arc of the wheel, ought to be filled with water. The wheel, then, carries down water at the following rate per second (all the dimensions being in feet):—

$$Q = \frac{2}{3} u l b \left(1 - \frac{b}{2r}\right); \dots\dots\dots(1.)$$

from which we deduce the following formula to determine the *clear breadth of wheel*, or *length of bucket*, l , when Q , u , r , and b , are given :—

$$l = \frac{3 Q}{2 u b \left(1 - \frac{b}{2r}\right)} \dots\dots\dots(2.)$$

157. **Figure and Dimensions of Buckets.**—The general figure of buckets has already been illustrated. It is usual to make the distance between their bottoms, measured along the sole plate, equal to the depth of the shrouding b .

The width of the opening between the lip of each bucket and the front of the bucket next above, when the wheel receives the water near the top, may be made $= \frac{1}{5} b$; but the lower the wheel receives the water, the wider must that opening be made; and as a general rule, when the inclination to the horizon of the wheel's circumference at the place where it receives the water exceeds 24° , the proper width is about

$$\frac{b}{2} \times \sin. \text{inclination.}$$

158. **Guide Blades and Regulator.**—As already shown in fig. 63, the water is supplied to the wheel between a series of guide blades.

These blades are from three to four inches apart, and their lower edges come within about 0.4 inch of the wheel. They are usually of cast iron, about three-eighths of an inch thick.

Their positions are determined by the following method, founded on the principles of Article 145 :—

In fig. 63, let $A B$ be a section of a bucket, B its lip. Draw the straight line $B D H$ a tangent to the circumference of the wheel; and make $\overline{B D} = u$, the surface velocity; and $\overline{B H} = 2 u$. Draw $D L$ parallel to a tangent to the lip of the bucket; draw $H C$ perpendicular to $B H$, cutting $D L$ in C ; join $B C$.

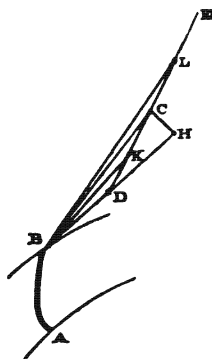

Fig. 63.

Then $\overline{B C}$ represents the best velocity v_1 for the supply of water to the wheel; and the middle outlet between the series of guide

blades is to be placed at the depth below the topwater level in the penstock due to that velocity, viz. :—

$$\frac{v_1^2}{2g} \dots \dots \dots (1.)$$

Also, $\angle HBC$ will be the proper angle for the guide blades of the middle outlet to make with the tangents to the circumference of the wheel at the points where they meet it, in order that the water may glide into the bucket without collision. It appears that the *co-efficient of contraction* for orifices between guide blades is about

$$c = 0.75 ; \dots \dots \dots (2.)$$

consequently, the total area of the outlets required for the flow Q , is given approximately by the formula,

$$A = \frac{4Q}{3v_1} ; \dots \dots \dots (3.)$$

and this is to be provided by having a sufficient number of outlets before and behind the middle outlet.

The positions of the guide blades for these outlets are found as follows :—

Take the depth of the narrowest part of each outlet below the topwater level of the penstock ; compute the velocity due to that depth ; from B lay off distances, such as \overline{BK} , \overline{BL} , representing those velocities, so as to find a series of points, such as K , L , in the line DC ; then will $\angle HBK$, $\angle HBL$, be respectively the proper inclinations to tangents to the wheel, for the guide blades of outlets where the velocities are \overline{BK} , \overline{BL} ; and so on for other guide blades.

The formula 3 gives a total area of outlet rather greater than is absolutely necessary ; but this is the best side to err on, as any excess of outlet can be closed by the regulator.

Besides computing the area of the outlets between the guide blades, the height of the topwater above the regulator, necessary to give the required flow Q , treating the regulator as an overfall with the *co-efficient of contraction* 0.7, should be computed by the formula

$$h = \left(\frac{Q}{3.75l} \right)^{\frac{2}{3}} ; \dots \dots \dots (4.)$$

and the depth of the upper edge of the lowest guide blade below the topwater level should be made not less than the height so found.

159. **Breast—Tail Race.**—When the width of the opening of the bucket is only about one-fourth or one-fifth of the depth of the

shrouding, that is, when the wheel receives the water within about 30° of the top, the breast is unnecessary; but for greater openings of the bucket, it is required.

The tail race, according to Mr. Fairbairn, should commence at 10 inches behind a vertical line let fall from the axis, and should be at least 1½ foot or 2 feet deep at the commencement.

160. The Efficiency is found by the formulæ of Article 148, putting for α the angle H B C of fig. 63.

As a small proportion only of the energy exerted by the water on an overshot or breast wheel is due to impulse, the loss of efficiency by moderate deviations from the best surface velocity is but small. Thus, although the surface velocity of greatest efficiency is

$$u = \frac{v_1 \cos \alpha}{2},$$

that velocity may vary between the limits

$$0.3 (v_1 \cos \alpha) \text{ and } 0.7 (v_1 \cos \alpha)$$

without any important waste of energy.

If the average efficiency of overshot and breast wheels, designed and constructed in the best manner, be estimated at 0.75, it follows that the energy of the available fall, from the penstock to the tail race, to give *one effective horse-power*, is on an average,

$$\frac{33,000}{0.75} = 44,000 \text{ foot-lbs. per minute.}$$

161. *Overshot Wheels at High Speeds* (A. M., 634).—In a few cases of not very ordinary occurrence, it is necessary to give the wheel so great a speed that the centrifugal force causes a sensible proportion of the water to be spilt from the buckets during their descent.

In fig. 64, let C represent the axis of the wheel, and B a bucket. Let a denote the *angular velocity* of the wheel, whose value is

$$a = \frac{u}{r} \dots \dots \dots (1.)$$

Take \overline{CA} vertically upwards from the axis, to represent, as given by the equation

$$\overline{CA} = \frac{g r^2}{u^2} = \frac{g}{a^2} = \frac{g}{4 \pi^2 n^2} \dots \dots \dots (2.)$$

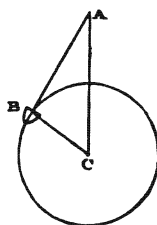

Fig. 64.

where n is the number of revolutions per second. Then the surface of the water in the bucket is perpendicular to \overline{AB} .

The height of A above C is independent of every circumstance except the time of revolution; being, in fact, the height of a revolving pendulum which revolves in the same time with the wheel (see Article 19). The point A is the same for all buckets carried by the same wheel with the same angular velocity, and for all points in the surface of the water in the same bucket, whether nearer to or farther from the axis C; so that the upper surface of the water in each bucket is part of a cylinder described about an axis traversing A, and parallel to the axis of the wheel.

By drawing a vertical section of the circle of buckets to a scale, finding the point A, and describing arcs about it to represent the surface of the water in each bucket, the waste of water and of energy by centrifugal force may be determined. If A is in the circumference of the wheel, no water can enter the buckets.

SECTION 3.—Of Undershot Wheels.

162. **Description of a Poncelet Wheel.**—The wheel represented in fig. 65 is one erected in England by Mr. Fairbairn, and is of the

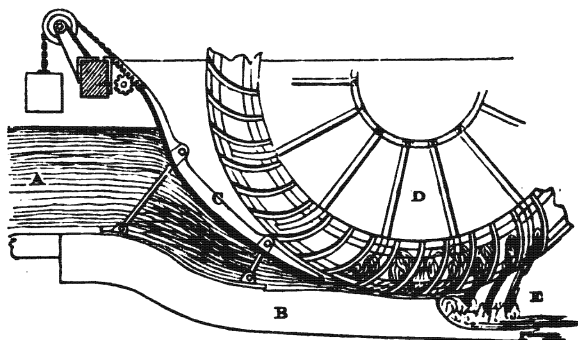

Fig. 65.

best design in every respect except one, viz, that the bottom of the wheel race is straight, instead of being curved in a manner which will be described in Article 166.

A is the reservoir; B, the wheel race; C, the regulating sluice, held against the pressure of the water by jointed links, balanced by a counterpoise, and moved by a rack and pinion; D, the wheel, having a pair of crowns, no sole plate, and a series of curved vanes; E, the tail race, with a drop into it from the end of the wheel race, as for a breast wheel.

163. **Diameter of Wheel.**—When not fixed by other considera-

tions, it is usual to make the diameter of the wheel about double the fall.

164. The **Depth of Shrouding** ought to be sufficient to prevent the water which glides up the vanes from overflowing their upper edges; because in order to produce the best efficiency, the water should all glide down again, and glance off at the lower edges of the vanes.

The best velocity of the water relatively to the vanes is about 0.4 of the velocity of supply v_1 ; but to provide for the contingency of that velocity amounting to 0.7 v_1 , it is advisable to give the shrouding the depth due to 0.7 v_1 ; that is to say, *about half the depth from the topwater level in the penstock to the outlet of the sluice.*

165. The **Regulating Sluice** is placed as close as possible to the wheel, and is consequently inclined. The co-efficient of contraction c of its outlet (as already stated, Article 140), is from 0.74 to 0.8; therefore, the depth of its opening is from four-thirds to five-fourths of the depth of the stream which issues from it.

The greatest depth of that stream should not exceed about one-fifth of the depth of the shrouding; therefore, the depth of opening of the sluice for the *maximum flow* should be about one-fourth of the depth of the shrouding, or one-eighth of the depth of the centre of the orifice below the topwater level.

Let Q be the greatest flow to be used, in cubic feet per second;

h' , the depth of the middle of the orifice below topwater;

d , the depth of the orifice;

l , the *length* of the orifice, or *breadth* of the opening of the sluice;

then

$$l = \frac{Q}{c d v_1} = \frac{Q}{c d \sqrt{2 g h'}}$$

all dimensions being in feet.

166. The **Wheel Race** is designed as follows (see fig. 66):— Draw $H F G$ a tangent to the wheel, with a declivity of one in ten. This declivity is to preserve the velocity of supply v_1 undiminished.

At the height $c d$ (Article 165) above $H F G$, draw $K L$ to represent the upper surface of the stream, meeting the circumference of the wheel at the point L . Then make the section of the bottom of the wheel race from G to F an arc of a circle, equal to $G L$, and of the same radius; that is, the radius of the wheel.

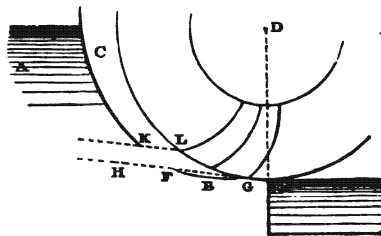

Fig. 66.

From G to E the wheel race is formed so as to clear the wheel by about 0·4 inch.

167. The **Surface Velocity** of the wheel for the greatest efficiency has already been stated, in Article 146, to be

$$u_1 = \cdot 6 v_1 \cos \alpha \dots \dots \dots (1.)$$

In this expression, α is to be held to represent the *mean* angle which the stream makes with a tangent to the wheel, which is very nearly

$$\alpha = \frac{1}{2} \text{arc. versin. } \frac{c d}{r} \dots \dots \dots (2.)$$

168. **Vanes or Floats.**—As to the number of vanes, from two to three in the length of the arc L G are in general enough.

The determination of the proper form for those vanes, near their outer edges, has already been explained in Articles 145, 146. They are usually curved in a circular arc, so that their inner ends are tangents to radii of the wheel.

169. The **Efficiency** has been stated, in Article 148, to be about 0·6 when the wheel is not drowned, and 0·48 when it is drowned. At these rates, the energy of the available fall from the penstock to the tail race, for each *effective horse-power*, is

	Foot-lbs. per minute.
For the undrowned wheel,	$\frac{33,000}{0.6} = 55,000$

	$\frac{33,000}{0.48} = 68,750$
--	--------------------------------

170. **Wheel in an Open Current.**—Wheels of this class are carried by boats moored in a rapid current. Their floats are usually plane and radial, and fixed at distances apart equal to their length in the direction of a radius.

According to the experiments of Poncelet, the following is the useful work per second of such a wheel; v_1 being the velocity of the current; u , that of the centre of a float; A , the area of a float in square feet; and D , the weight of a cubic foot of water:—

$$R u = 0.8 \frac{D A v_1 (v_1 - u) u}{g}$$

According to this formula, the velocity of the centres of the floats for the greatest efficiency is half the velocity of the current; and the efficiency at that speed is 0·4, if $A v_1$ be taken to represent the volume of water acting on the wheel in a second.

CHAPTER VI.

OF TURBINES.

SECTION I.—*General Principles.*

171. **Turbines Generally Described and Classed.**—A turbine is a water wheel with a vertical axis, receiving and discharging water in various directions round its circumference. The wheel consists of a *drum* or annular passage, containing a set of suitably formed *vanes*, which are curved backwards in such a manner, that the water, after glancing off them, is left behind with as little energy as possible.

Turbines have the advantage of being of small bulk for their power, and equally efficient for the highest and the lowest falls.

The supply of water takes place either directly from a reservoir, in which case the wheel is placed close to a suitable opening at the bottom of the reservoir, or through a supply pipe and wheel case. The former method is the best suited to moderate falls, the latter to very high falls.

The opening through which the water is delivered to the wheel is in most cases furnished with *guide blades*, to make the water arrive at the wheel in the direction best suited to drive it efficiently.

Turbines may be divided into three classes, according to the direction in which the water moves before reaching the guide blades, and after leaving the wheel, viz :—

I. *Parallel Flow Turbines*, in which the water is supplied and discharged in a current parallel to the axis.

II. *Outward Flow Turbines*, in which the water is supplied and discharged in currents radiating from the axis.

III. *Inward Flow Turbines*, in which the water is supplied and discharged in currents converging radially towards the axis.

Those three classes of turbines differ in certain details; but there are general principles which are applicable to them all, and general equations which are adapted to any one of them merely by assigning suitable values to certain symbols in them. The diagrams which will now be given show the general arrangement of the principal parts of each, the details of their construction being reserved until later.

Fig. 67 represents a parallel flow turbine. A is the supply

chamber, being an annular passage through the bottom of the reservoir, which contains the guide blades; these are vertical at

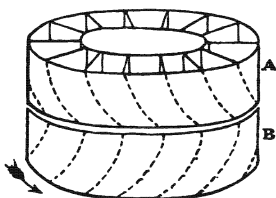

Fig. 67.

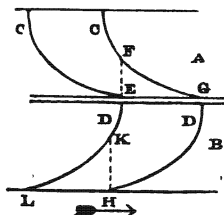

Fig. 68.

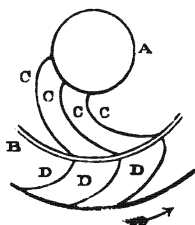

Fig. 69.

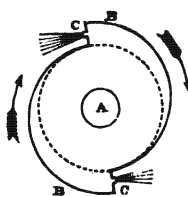

Fig. 70.

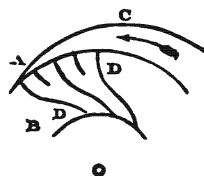

Fig. 71.

their upper edges: the form and position of their lower edges, as shown by dotted lines, are such as to direct the water in several small streams or jets obliquely against all parts of the circumference of the wheel B. The wheel B consists also of an annular passage between two cylindrical drums, containing a series of vanes, resembling the guide blades in shape, but turned with their lower edges pointing backwards.

Fig. 68 shows a vertical section of a few of the guide blades C, and vanes D.

Fig. 69 is a horizontal section of part of an outward flow turbine; A is the supply chamber, being a vertical cylinder with a ring of openings round its lower end; C are the guide blades for directing the water obliquely forwards as it rushes out of these openings; B is the wheel surrounding the ring of openings, and consisting of a pair of crowns, or flat rings, with a series of curved vanes D between them; these vanes are radial at their inner edges, and directed obliquely backwards at their outer edges.

Fig. 70 represents a plan of one form of the *reaction wheel*—a kind of outward flow turbine without guide blades. The water is conducted by a vertical supply pipe A into the centre of a rotating

hollow disc, provided with two or three hollow arms, which discharge the water through orifices directed backwards. In the figure, the hollow disc, and its two arms B B, are shown of such a form as to leave the largest possible space for the motion of the water from the centre of the disc towards the circumference, in order to avoid friction, and for other reasons which will afterwards appear. C, C, are the orifices. The circumferences of the arms B, B, here perform the functions of vanes.

Fig. 71 is a horizontal section of an *inward flow turbine*. A is the supply chamber; C, one of the guide blades, directing the water obliquely forwards against the wheel; B is the wheel, occupying a central space surrounded by the supply chamber, and discharging the water through openings in its centre; it consists of a pair of crowns with a set of curved vanes D between them: these vanes are radial at their outer ends, and are directed obliquely backwards at their inner ends.

In treating of the theory of the efficiency of turbines, it will be assumed that they are constructed of the forms and proportions, and worked in the manner most favourable to efficiency, according to rules which will presently be explained. The waste of power caused by deviations from those rules can afterwards be allowed for by means of empirically-found multipliers.

172. By **Velocity of Flow** is to be understood the velocity of that component of the motion of the water by which it is carried towards, through, and away from the wheel; that is, the component, whether parallel to the axis or radial, which is at right angles to the motion of the vanes.

Let A denote the total effective sectional area in square feet of the orifices through which the water passes, whether in the wheel, or amongst the guide blades, as measured upon a surface perpendicular to the direction of the flow; that is, in a parallel flow turbine, on a plane perpendicular to the axis, and in an outward or inward radial flow turbine, on a cylindrical surface described about the axis.

Let Q be the volume of water used in cubic feet per second. Then

$$Q \div A \dots \dots \dots (1.)$$

is the velocity of flow.

Inasmuch as sudden changes in the velocity of a stream are accompanied with waste of energy, it is desirable that the velocity of flow should either be constant, or change slowly during the passage of the water through the wheel.

In parallel flow turbines, such as fig. 67, the velocity of flow would be made constant, if the vanes were insensibly thin, by making the drum, or annular case containing the vanes, simply

cylindrical; but owing to the obliquity of the vanes at their lower edges, they occupy more of the passage there than at their upper edges; so that the drum has to be made to spread a little at its lower end, as will be shown afterwards in the detailed figure.

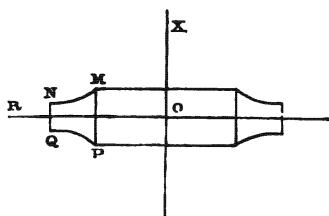

Fig. 72.

In radial flow turbines, the uniformity of the velocity of flow may be insured by making the vertical section of the drum of the wheel of the shape shown in fig. 72; that is to say, let O X be the axis; O R a radius at the middle of the depth of the wheel; the vertical sections M N, P Q, of the rings or crowns between which the vanes are carried are to be portions of hyperbolas having O X and O R for asymptotes; or in other words, the depths of the inside and outside circumferences of the wheel, M P, N Q, are to be inversely as their respective radii.

Out of the available head h_1 in the supply chamber, there will be expended to produce the velocity of flow, when that changes gradually or not at all,

$$\frac{Q^2}{2g A_1^2}; \dots \dots \dots (2.)$$

where A_1 denotes the sectional area of the stream where it leaves the wheel.

173. *Velocity of Whirl.*—Let v denote the *whirling* or *tangential* component of the velocity with which the water issues from between the guide blades and arrives upon the wheel. This is the velocity which would be computed by dividing Q by the sum of the effective areas of the openings between the guide blades, as measured upon the planes marked E F in fig. 68. It is evident that the *velocity of flow* has the following value in terms of this *initial velocity of whirl* :—

$$\frac{Q}{A} = v \cdot \frac{FE}{EG} = v \cdot \tan \alpha; \dots \dots \dots (1.)$$

$\alpha = \angle FGE$ being the inclination of the guide blades to the direction of the whirling motion.

The ordinary values of α range from 22° to 35° in different examples; and about 30° may be taken as an average value.

In order that the water may work to the best advantage, it should enter the wheel without shock, and leave it without whirling motion; for which purpose, the velocity of whirl, on first

entering the wheel, should be equal to that of the first circumference of the wheel, and the *velocity of whirl relatively to the wheel*, on leaving the wheel, should be equal and contrary to that of the second circumference of the wheel.

Consequently, the ratio of the latter of these velocities (w) to the former (v) should be that of the radius of the discharging side of the wheel to the radius of the receiving side. Let n denote that ratio; then $w = n v$; in which,

$$\left. \begin{array}{l} \text{for a parallel flow turbine, } n = 1; \\ \text{for an outward flow turbine, } n > 1; \\ \text{for an inward flow turbine, } n < 1; \end{array} \right\} \dots\dots\dots(2.)$$

and if the drum is made of that figure which causes the velocity of flow to be uniform, the angle $\beta = \angle H K L$ in fig. 68, which the hinder edges of the vanes make with a tangent to the wheel, should have the value given by the equation

$$\tan \beta = \frac{\overline{H K}}{\overline{H L}} = \frac{\tan \alpha}{n}; \dots\dots\dots(3.)$$

and as $\overline{H L} = n \cdot \overline{E G}$, this formula is equivalent to the following:—

$$\overline{H K} = \overline{E F} \dots\dots\dots(3 A.)$$

174. **Efficiency without Friction.**—The following investigation has reference to the case in which the supply of water is sufficient to fill the orifices and channels. Reference will be made in it to the principle of the *equality of angular impulse and angular momentum*—a consequence of the second law of motion, which will now be explained (*A. M.*, 560, 561, 562).

Let a body whose weight is W move with a velocity V in a given direction relatively to a point C ; let r denote the length of a perpendicular let fall from C upon a tangent to the path of the body W 's motion.

Then the *angular momentum* of W relatively to C means the quantity

$$\frac{W V r}{g}.$$

Let M denote the *moment of a couple* of equal and opposite, but not directly opposed, forces; that is, the product of their common magnitude into their *arm* or lever, which is the perpendicular distance between the lines along which they act.

The *angular impulse* of such a couple means, the product of its

moment into the time during which it acts. To produce a given change in the angular momentum of a body, an equal angular impulse is required—a principle expressed by the equation

$$M \, d t = \frac{W}{g} \cdot d (V r) \dots \dots \dots (1.)$$

To apply this to the action of water on a turbine, the weight of water acting in a second ($D Q$) is to be ascertained; when the moment of the couple exerted between it and the wheel will be measured simply by the change which its angular momentum undergoes in passing through the wheel.

The product of that couple into the angular velocity of the wheel a is the *energy* exerted by the water on the wheel in a second (Article 5).

I. *Computation of the Energy Exerted by the Water on the Wheel.*
—Let r be the radius of the wheel where it receives the water. (For parallel flow turbines, the *mean* radius may be taken.) Then $n r$ is its radius where it discharges the water, and $a r$, and $n a r$, are its two surface velocities.

Then, the velocity of whirl of the water when it enters the wheel being v , its *initial angular momentum per second* is

$$\frac{D Q v r}{g};$$

and as the velocity of whirl of the water when it leaves the wheel, as determined by the conditions of Article 173, is

$$n a r - w = n (a r - v),$$

its *final angular momentum per second* is

$$\frac{D Q n^2 (a r - v) r}{g};$$

the difference between these quantities, being the moment of the couple exerted between the water and the wheel, is

$$M = D Q \cdot \frac{(1 + n^2) v r - n^2 a r^2}{g}; \dots \dots \dots (2.)$$

and the *energy exerted per second* by the water on the wheel is

$$M a = D Q \cdot \frac{(1 + n^2) a v r - n^2 a^2 r^2}{g} \dots \dots \dots (3.)$$

The factor by which $D Q$ is multiplied in equation 3 is the *effective head*, neglecting friction.

II. *Computation of the Energy Expended.*—This calculation is best made by finding the head required to produce the various velocities that are given to the water.

To produce the *final velocity of flow* $n v \tan \beta$, there is required the head

$$n^2 v^2 \tan^2 \beta \div 2 g.$$

To produce the *initial velocity of whirl* v , there is required the head

$$v^2 \div 2 g.$$

To produce the reversed relative velocity of whirl with which the water leaves the wheel, $w = n v$, there is required the head

$$n^2 v^2 \div 2 g ;$$

and to balance centrifugal force, the head

$$a^2 r^2 (1 - n^2) \div 2 g,$$

which is $\left\{ \begin{array}{l} \text{negative} \\ \text{nothing} \\ \text{positive} \end{array} \right\}$ for $\left\{ \begin{array}{l} \text{outward flow} \\ \text{parallel flow} \\ \text{inward flow} \end{array} \right\}$ turbines.

Putting these quantities of head together, we find for the *head in the supply chamber*,

$$h_1 = \frac{1}{2g} \left\{ (1 + n^2 + n^2 \tan^2 \beta) v^2 + (1 - n^2) a^2 r^2 \right\} ; \dots(4.)$$

for the energy expended at the wheel, per second,

$$D Q h_1 ; \dots\dots\dots(5.)$$

and for the **EFFICIENCY** (neglecting friction),

$$\frac{M a}{D Q h_1} = \frac{2 (1 + n^2) a v r - 2 n^2 a^2 r^2}{(1 + n^2 + n^2 \tan^2 \beta) v^2 + (1 - n^2) a^2 r^2} \dots\dots(6.)$$

The above are general expressions for all turbines with guide blades. For parallel flow turbines, they become

$$h_1 = \frac{1}{2g} (2 + \tan^2 \beta) v^2 ; \dots\dots\dots(7.)$$

$$\frac{M a}{D Q h_1} = \frac{4 a v r - 2 a^2 r^2}{(2 + \tan^2 \beta) v^2} \dots\dots\dots(8.)$$

By the aid of equation 4, v can be expressed in terms of h_1 and $a r$, so as to transform equations 6 and 8, as follows:—

$$v = \frac{\sqrt{2g h_1 - (1 - n^2) a^2 r^2}}{\sqrt{1 + n^2 + n^2 \tan^2 \beta}}; \dots\dots\dots (9.)$$

Let $\frac{a r}{\sqrt{2g h_1}} = z$, then,

$$\frac{M a}{D Q h_1} = \frac{2(1 + n^2) z \cdot \sqrt{1 - z^2 + n^2 z^2}}{\sqrt{1 + n^2 + n^2 \tan^2 \beta}} - 2 n^2 z^2; \dots (10.)$$

which, when $n = 1$, becomes

$$\frac{M a}{D Q h_1} = \frac{4 z}{\sqrt{2 + \tan^2 \beta}} - 2 z^2 \dots\dots\dots (11.)$$

The efficiency of the reaction wheel is a special case, which will be considered in Article 176.

175. **The Greatest Efficiency without Friction** is attained, as has been stated in Article 173, when

$$v = a r \dots\dots\dots (1.)$$

Substituting this value of v in equation 4 of the last Article, we find

$$h_1 = (2 + n^2 \tan^2 \beta) \cdot \frac{a^2 r^2}{2g}; \dots\dots\dots (2.)$$

and, consequently, the surface velocity of the wheel, where it receives the water, should be

$$a r = \sqrt{\left(\frac{2g h_1}{2 + n^2 \tan^2 \beta} \right)} \dots\dots\dots (3.)$$

So that in equations 10 and 11,

$$z = \frac{1}{\sqrt{2 + n^2 \tan^2 \beta}}.$$

The efficiency corresponding to this speed is

$$\frac{M a}{D Q h_1} = \frac{2}{2 + n^2 \tan^2 \beta} = 2 z^2 \dots\dots\dots (4.)$$

showing that the only energy lost is that due to the final velocity of flow, $n v \tan \beta = n a r \tan \beta$.

The following table shows some values of the best speed as compared with the speed due to the whole available head, and of the greatest efficiency, neglecting friction, for a few values of the obliquity β of the vanes, and on different suppositions as to the value of n :—

β for $n = \sqrt{2}$.	β for $n = 1$.	β for $n = \frac{1}{2}$.	$n \tan \beta$.	z .	$\frac{M a}{D Q h_1} = 2 z^2$.
$14^{\circ}\frac{1}{2}$	20°	36°	.364	.685	.93
$18^{\circ}\frac{1}{4}$	25°	43°	.466	.672	.90
$22^{\circ}\frac{1}{4}$	30°	49°	.577	.655	.86
$26^{\circ}\frac{1}{2}$	35°	$54^{\circ}\frac{1}{2}$.700	.634	.80

The proportion $n = \sqrt{2}$ is usual in outward flow turbines, such as Fourneyron's; $n = \frac{1}{2}$ is usual in inward flow turbines, such as Thomson's vortex wheel.

The case of $n = 1, \beta = 30^{\circ}$, is very nearly that of Fontaine's parallel flow turbines. Theory gives, as the above table shows, for the best velocity of the wheel, at the middle of the ring of vanes,

$$a r = .655 \sqrt{2 g h_1} \dots \dots \dots (5.)$$

The experiments of General Morin give

$$a r = .645 \sqrt{2 g h_1} ;$$

and the agreement is as close as can be expected.

176. The **Reaction Wheel** is equivalent to an outward flow turbine in which $\beta = 0, r = 0, z = 0$; while for $n r$ is to be substituted r' , the radius from the axis to the centres of the orifices; for $n v$ is to be put w , its original symbol; for $n z$ is to be substituted

$$z' = \frac{a r'}{\sqrt{2 g h}} ;$$

Then for the velocity of outflow of the water from the orifices, we have

$$w = \sqrt{2 g h_1 + a^2 r'^2} = \sqrt{1 + z'^2} \sqrt{2 g h} ; \dots \dots (1.)$$

and for the efficiency, neglecting friction,

$$\frac{M a}{D Q h_1} = \frac{2 z'}{z' + \sqrt{1 + z'^2}} \dots \dots \dots (2.)$$

This expression increases towards the limit 1, or perfect efficiency, as z' increases without limit; so that if there were no friction, the efficiency of a reaction wheel would have no maximum, but would increase towards unity as the velocity increased without limit.

177. **Efficiency of Turbines, Allowing for Friction.**—I. *Parallel Flow Turbines.*—The fact stated in Article 175, that the best

actual speed of these turbines is the same with that calculated in the supposition that there is no friction, shows that the loss of energy by friction may be allowed for by multiplying by a constant factor, less than unity.

From the experiments of General Morin and others, it appears that the value of that factor is nearly the same as for the best overshoot and undershot wheels; that is to say, $(1 - k'')$ = from .75 to .8, with an average value of about .78.

If we multiply the efficiencies in the table of Article 175, corresponding to $n = 1$, $\beta = 25^\circ$, and 30° , we find the following results, which agree well with experiment:—

β	$z z^2$	$1 - k''$			
		.75	.78	.8	
25°	.90	.675	.702	.72	} resultant
30°	.86	.645	.671	.688	} efficiency.

II. *Inward Flow Turbines*.—In these turbines, the co-efficient $(1 - k'')$ appears to be about the same as for parallel flow turbines;

which, for $\beta = 36^\circ$, $n = \frac{1}{2}$, gives, as the average resultant efficiency, about .73—a conclusion confirmed by practical experience.

III. *Outward Flow Turbines*, which generally work drowned, lose in overcoming fluid friction a quantity of work per second, which has been shown by Poncelet, and by General Morin, to be proportional to the volume of flow, and to the height due to the velocity of the outer circumference of the wheel. That velocity being denoted by $n a r = n z \sqrt{2 g h_1}$, the loss of work per second by friction is

$$f D Q \frac{n^2 a^2 r^2}{2 g} = f D Q n^2 z^2 h_1; \dots\dots\dots(1.)$$

being the fraction $f n^2 z^2$ of the energy expended.

f is a co-efficient of friction, whose value, as deduced from experiments by General Morin, is nearly

$$f = 0.25.$$

This cause of loss of work not only diminishes the efficiency of the turbine, but diminishes very considerably the speed of greatest efficiency.

Subtracting $f n^2 z^2$ from equation 10 of Article 174, we find for the actual efficiency of an outward flow turbine, at any given velocity $a r = z \sqrt{2 g h_1}$ of its inner periphery, the value

$$\frac{M a}{D Q h_1} = \frac{2(n^2 + 1) \cdot z \cdot \sqrt{1 + (n^2 - 1) z^2}}{\sqrt{1 + n^2 \cdot \sec^2 \beta}} - (2 + f) n^2 z^2 \quad (2.)$$

The following are the results of investigating the conditions which make this quantity a maximum :—

Let $a_1 r = z_1 \sqrt{2 g h_1}$ be the best speed.

For brevity's sake, let

$$\sqrt{\left\{ (2 + f)^2 n^4 - \frac{4(n^4 - 1)(n^2 + 1)}{1 + n^2 \sec^2 \beta} \right\}} = U.$$

Then

$$z_1 = \sqrt{\left\{ \frac{(2 + f) n^2 - U}{2(n^2 - 1) U} \right\}}; \dots\dots\dots (3.)$$

and the greatest efficiency is given by the formula

$$\frac{M_1 a_1}{D Q h_1} = U z_1^2 = \frac{(2 + f) n^2 - U}{2(n^2 - 1)} \dots\dots\dots (4.)$$

As a numerical example and verification of these formulæ, the case may be taken of a Fourneyron's turbine, for which

$$n^2 = 2 \text{ nearly;}$$

$$f = 0.25;$$

$$n^2 \tan^2 \beta = \frac{1}{2} \text{ nearly.}$$

Using these data, we find $U = 3.16$, and, consequently,

$$\left. \begin{aligned} z_1 &= \sqrt{\cdot 215} = \cdot 464; \\ U z_1^2 &= \cdot 68; \end{aligned} \right\} \dots\dots\dots (5.)$$

Efficiency,

results which exactly agree with those of experiment.

IV. *Reaction Wheel.*—If we assume that this wheel is resisted in the same manner with an outward flow turbine, and denote, as in Article 176, the ratio of the speed of the orifice to that due to the available head by z' , and the best value of that ratio by z'_1 , we find, for the efficiency in general,

$$\frac{M a}{D Q h_1} = \frac{2 z'}{z' + \sqrt{1 + z'^2}} - f z'^2; \dots\dots\dots (1.)$$

which being made a maximum, gives

$$z'_1 = \sqrt{\left\{ \frac{2 + f - \sqrt{(2 + f)^2 - 4}}{2 \sqrt{(2 + f)^2 - 4}} \right\}}; \dots\dots\dots (2.)$$

$$\frac{M_1 a_1}{D Q h_1} = \frac{2 + f - \sqrt{(2 + f)^2 - 4}}{2} \dots\dots\dots (3.)$$

From experiments by Professor Weisbach, it appears, that the greatest efficiency of a good reaction wheel is

$$\frac{M_1 a_1}{D Q h_1} = .666 ; \dots\dots\dots(4.)$$

which value being substituted in equation 3, gives for the co-efficient of friction

$$f = .136 ; \dots\dots\dots(5.)$$

and for the ratio of the best speed of the orifices to that due to the available fall,

$$z_1 = .97 \dots\dots\dots(6.)$$

This result is confirmed by general experience of the working of these wheels, from which it appears that the best velocity for the orifices is very nearly equal to that due to the available fall, and the greatest efficiency about $\frac{2}{3}$.

178. **Volume of Flow and Size of Orifices.**— In Article 174, equation 9, an expression is given for the *whirling* or *tangential component* of the velocity of flow through the openings between the guide blades ; from which are deduced the following expressions for the total velocities, through the openings between the guide blades, and through the openings between the vanes of the wheel respectively ; in which, Q being as before the volume of flow per second, the joint area of the *contracted stream* in the former set of openings is denoted by O_1 , and that in the latter set by O_2 :—

$$\frac{Q}{O_1} = v \sec \alpha = \sec \alpha \cdot \sqrt{2 g h_1} \cdot \frac{\sqrt{1 + (n^2 - 1) z^2}}{\sqrt{1 + n^2 \sec^2 \beta}} ; \dots(1.)$$

$$\frac{Q}{O_2} = n v \sec \beta = \sec \beta \cdot \sqrt{2 g h_1} \cdot \frac{n \cdot \sqrt{1 + (n^2 - 1) z^2}}{\sqrt{1 + n^2 \sec^2 \beta}} (2.)$$

For reaction wheels,

$$\frac{Q}{O_2} = w = \sqrt{2 g h_1} \cdot \sqrt{1 + z^2} \dots\dots\dots (2 A.)$$

The formulæ

$$O_1 = \frac{Q}{v \sec \alpha} ; O_2 = \frac{Q}{n v \sec \beta} = \frac{Q}{w \sec \beta} \dots\dots\dots(3.)$$

serve to determine the effective areas of inlet and outlet required to employ to the best advantage a given flow of water in a given

wheel, with a given available fall and speed, the speed being that of greatest efficiency, computed as in Articles 175 and 177.

The *co-efficient of contraction* for the inlets and outlets of turbines ranges from '85 to '95, and is about '9 on an average; so that the actual openings are to be made *one-ninth larger than those given by the equations.*

179. *Efficiency as affected by Regulator.*—The flow of water through a turbine is controlled by a regulating valve, of which different kinds will afterwards be described.

In parallel flow and outward flow turbines, the regulator usually consists of a set of slide valves applied to the orifices of supply between the guide blades.

In the best form of reaction wheel, known as Whitelaw and Stirrat's, the regulator consists of slide valves applied to the orifices at the ends of the arms.

In Thomson's inward flow turbine, the regulator consists of the guide blades themselves, which turn about axes near their inner ends, so as to be set at any required angle α to the circumference of the wheel.

The preceding investigations and statements of efficiency have reference to the case in which the passages of supply are uninterrupted, or nearly so. Their partial closing by slide valves causes loss of energy through sudden contractions and expansions of the stream.

The following are average values of the reductions of efficiency produced by partial closing of the supply passages by slide valves:—

$$\text{Ratio of the actual opening } \left. \begin{array}{l} \text{to the full opening,} \end{array} \right\} \begin{array}{l} 1 \\ 5 \end{array} \quad \begin{array}{l} 2 \\ 5 \end{array} \quad \begin{array}{l} 1 \\ 2 \end{array}$$

$$\text{Ratio of the diminished effi-} \left. \begin{array}{l} \text{ciency to the maximum} \\ \text{efficiency,} \end{array} \right\} \begin{array}{l} 1 \\ 2 \end{array} \quad \begin{array}{l} 2 \\ 3 \end{array} \quad \begin{array}{l} 5 \\ 6 \end{array}$$

Such diminutions of efficiency do not occur where the flow is regulated by varying the orifices of discharge, or by varying the inclination of the guide blades.

SECTION 2.—Description of Various Turbines.

180. *Fontaine's Turbine*, a parallel flow turbine, the invention of M. Fontaine-Baron, is illustrated by fig. 73, which is a vertical diametral section, and by fig. 74, which is a vertical section by a cylindrical surface traversing the guide blades and vanes, like that given in an elementary form in fig. 68.

A is the tank or reservoir, in the bottom of which is the ring-

shaped cast iron passage B, containing the guide blades *e*, and regulating sluice valves *d*. There are as many sluices as guide blades,

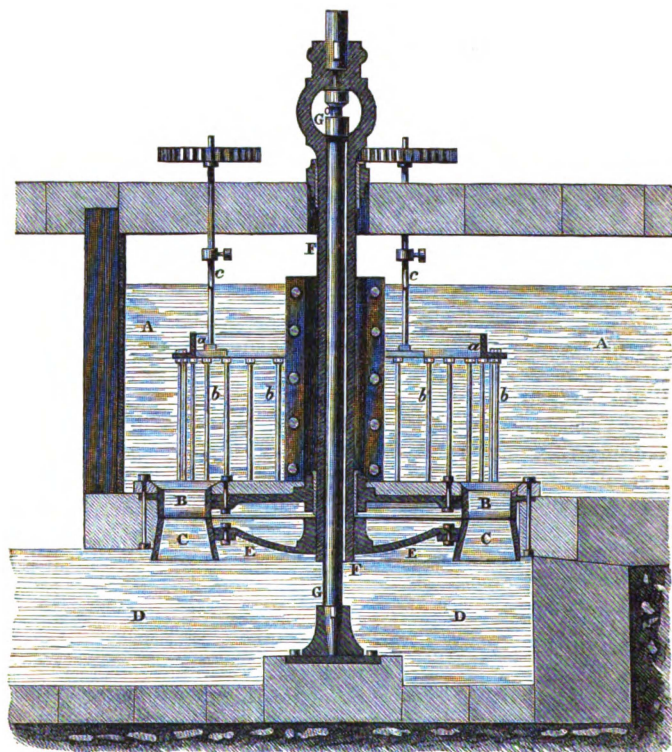

Fig. 78.

each guide blade having a sluice sliding vertically behind it. The backs of the sluices are rounded, so as to make the contraction and deflection of the stream gradual. Each sluice is hung by a rod *b* from the iron ring *a*, which is raised and lowered by means of three rods marked *c*, so as to raise, lower, or close, the whole of the sluices at once.

C is the drum or annular passage of the wheel, containing the vanes *f*. *E* is a disc, by which the drum is carried. The disc, drum, and vanes, may all be cast in one piece.

F F is the hollow vertical shaft of the wheel, at the top of which

is the pivot, supported upon the top of the fixed vertical spindle G, which rises from the bottom of the tail race within the hollow shaft. The object of this is to facilitate the oiling of the pivot.

The dimensions and proportions of turbines of this class may be varied to suit different circumstances; nevertheless the following are given as being usual in practice, on the authority of General Morin :—

- α , obliquity of the guide blades, 22° to 25° .
- β , obliquity of the vanes,..... 20° to 30° .

Breadth of ring-shaped passages—

$$= \text{from } \frac{1}{10} \text{ to } \frac{1}{15} \text{ of mean diameter of wheel.}$$

Least depths of openings between guide blades, and between vanes, from $2\frac{1}{2}$ inches to 6 inches.

Depth of drum of wheel = depth of openings \times 2.

As to the work, efficiency, best speed, and volume of flow, see Articles 172, 173, 174, 175, 177, Division I., 178.

The speed may deviate from the best speed to the extent of one quarter, without materially diminishing the efficiency. As to the effect of the sluices, see Article 179.

To avoid the diminution of efficiency by the lowering of the sluices, *double turbines* have been used, consisting of a pair of concentric wheels made in one piece, supplied with water by a similar pair of concentric annular supply passages. Each of those passages has its own set of sluices, hung from an independent ring; so that either division of the double wheel can have its supply of water cut off at pleasure. Thus the power of the turbine can be varied in a proportion exceeding that of two to one, without the necessity for employing very contracted orifices, and consequently wasting energy.

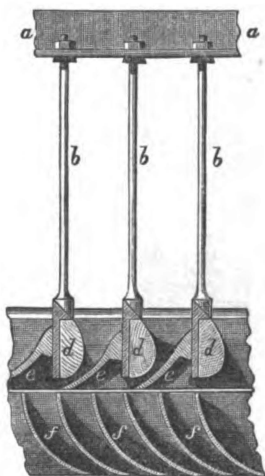

Fig. 74.

181. **Jonval's, or Koechlin's Turbine**, the invention of M. Jonval, and made by Messrs. Koechlin & Co., resembles Fontaine's turbine, with the wheel working in a vertical *suction pipe* (Article 105) in which the pressure is below that of the atmosphere. This enables the wheel to be placed at any convenient elevation not exceeding the head equivalent to one atmosphere, above the level

of the surface of the tail race, without incurring (as would be the case in the absence of the suction pipe) a loss of head equal to the drop from the bottom of the wheel to the water level of the tail race.

182. **Fournayron's Turbine**, one of the earliest and best known of turbines with guide blades, is an *outward flow turbine*. The average ratio of the outer to the inner radius of the wheel is $n = \sqrt{2}$, and the depth of the wheel is about equal to, or a little greater than the breadth of the crowns.

An example is represented in figs. 75, 76, of which fig. 75 is a vertical section, and fig. 76 a sectional plan of the wheel and supply cylinder, showing the form and arrangement of the guide blades and vanes.

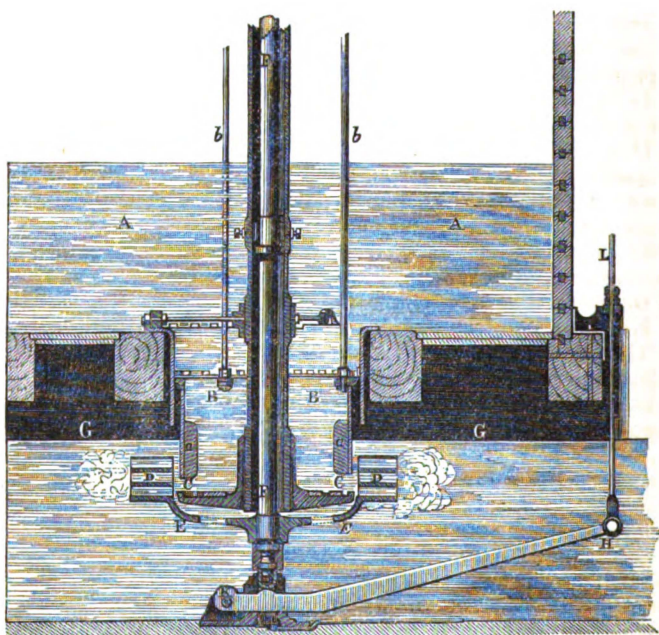

Fig. 75.

A is the tank or penstock ; B, the supply cylinder. This is the arrangement for moderate falls ; for very high falls, the water may be brought down from a reservoir to the supply cylinder by a pipe, whose resistance must be allowed for in determining the available fall.

The cylinder B consists of two concentric tubes: the upper is fixed: the lower slides within it like the inner tube of a telescope, and is raised and lowered by means of the rods *b*. Near the upper edge of the inner tube is a leather collar, to make the joint between it and the outer tube water-tight. The lower part *a* of the inner tube acts as a regulating sluice for all the orifices at once. It has fixed to its internal surface wooden blocks, so shaped as to round off the turns in the course of the water towards the orifices.

The bottom of the supply cylinder is formed by a fixed disc C, which is supported by hanging at the lower end of a fixed vertical tube enclosing the shaft. This disc carries the guide blades.

D are the vanes of the wheel. In the example shown, the passages between the vanes are divided into three sets, or horizontal layers, by two intermediate crowns or horizontal ring-shaped partitions. The object of this is to secure that the passages shall be filled by the stream at three different elevations of the sluice, and so to diminish the loss of efficiency which occurs when the opening of the sluice is small.

E is the disc of the wheel; F, its shaft; G, the tail race.

The pivot at the lower end of the shaft is supplied with oil through a small tube seen in the figure, which is laid down one side and along the bottom of the tail race, and rises directly below the pivot.

K H is a lever which supports the step of the pivot, and is itself supported by fixed bearings at K, and by a rod, L, which can be raised or lowered by a screw, so as to adjust the wheel to the proper level.

183. Various Outward Flow Turbines.—An improvement in the regulating apparatus of Fourneyron's turbine, introduced by Mr. Redtenbacher, is to vary the supply openings when required, by raising or lowering the disc C which carries the guide blades, by means of a screw at the top of the tube to which it is fixed. This dispenses with the necessity for an internal sliding cylinder within the fixed supply cylinder.

Another modification of the regulating apparatus of Fourneyron's turbine, by M. Callon, is to make the sliding vertical tubular sluice in several segments, which can be opened or shut separately.

To prevent the drowning of Fourneyron's turbine, M. Girard

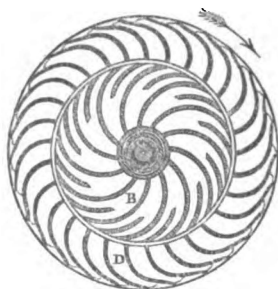

Fig. 76.

added to it a bell, or fixed vertical cylinder with the mouth downwards, which dips into the tail race, and within which the wheel works. A sufficient quantity of air is enclosed in the bell to keep the surface of the water within it below the level of the wheel; and the gradual loss of this air by leakage and diffusion in the water is supplied by means of a small forcing pump. It is of course the level of the water in the tail race *outside* the bell, that is to be taken into account in estimating the available head.

It is probable that the effect of this may be to make the best *inside-surface speed* $a_1 r$, and the maximum efficiency, the same as for parallel flow turbines, viz. :—

$$a_1 r = z_1 \sqrt{2 g h_1} = \sqrt{2 g h_1} \cdot \frac{1}{\sqrt{2 + n^2 \tan^2 \beta}}; \dots\dots (1.)$$

$$\frac{M_1 a_1}{D Q h_1} = 2 z_1^2 (1 - k''') = \frac{2(1 - k''')}{2 + n^2 \tan^2 \beta}; \dots\dots (2.)$$

1 — k''' being from .75 to .8, and on an average about .78.

184. **Reaction Wheels.**—This class of wheels, of which the theory has been given in Articles 176, 177, Division III., and 178, comprehends all *turbines without guide blades*, of which a great variety have been contrived and used. The earliest form, well known as "Barker's Mill," discharged the water from orifices in the ends of straight tubular arms projecting from a hollow shaft. The friction of the water in the arms caused considerable loss of energy. Tubular arms, curved in various ways, were afterwards employed; but it is obvious that in any curved arm the friction must be greater than in a straight arm of the same diameter. The best form is one more or less resembling fig. 71; that is, a hollow disc, with projections leading the water to nozzles of a form approximating to that of the contracted vein. In the figure there are two nozzles; but three are better calculated to insure steady motion, provided they are exactly similar and equal.

The best mode of regulating the flow is that introduced by Messrs. Whitelaw and Stirrat, of having the regulating valves at the orifices of discharge. This insures nearly equal efficiency at all openings of the orifices.

The best mode of making the water-tight joint between the supply pipe and disc is that sketched in fig. 77. A is the supply pipe; B, the wheel, or hollow disc; C, the vertical shaft; D, the neck of the wheel through which it receives the water. Near the end of the neck is an annular recess containing a cupped leather collar, within which fits a tube E. The outer edge of this tube, scraped to a true plane, is pressed by the pressure of the water over the equal area of the inner edge, against the truly plane surface of

the flange F of the supply pipe, upon which flange it turns round, making a good joint with very little friction.

Another form of this arrangement consists in having the annular recess and collar within which the tube E fits, at the end of the supply pipe, and the flange against which the outer edge of the tube presses, at the end of the neck of the wheel.

To diminish as much as possible the friction and wear of pivots or other bearings, the vertical shaft should be loaded with a weight sufficient to balance the pressure of the water on the area of the openings of the neck of the wheel, or of the supply pipe, whichever is the greater.

Another mode of balancing the pressure is that devised by Mr. Redtenbacher, who has in some cases employed a *vertical* outward flow double turbine, consisting of a pair of reaction wheels at the two ends of one horizontal shaft, supplied from the same intermediate horizontal supply cylinder, to which the water is introduced by a pipe at one side. This construction is suitable to high falls, and possesses a further advantage in the fact that the shaft rests on horizontal journals and bearings, which are more easily kept in order than pivots.

185. *Thomson's Turbine, or Vortex Wheel.*—This wheel, the invention of Professor James Thomson of Queen's College, Belfast, is the only example yet in use of the *inward flow turbine*, whose general theory has been explained in Section 1 of the present Chapter.

The following description is for the most part extracted from a paper by the inventor in the Report of the Meeting of the British Association in 1852.

There is a difference in the construction of this turbine for high and for low falls, analogous to that which is found in Fourneyron's turbine; that is to say, for low falls the supply chamber may be an open tank; while for high falls it must generally be a closed vessel, supplied by a pipe from an elevated reservoir. Fig. 78 is a vertical section, and fig. 79 a horizontal section and plan of a high pressure vortex wheel, for a fall of about thirty-seven feet. The dimensions of these figures are $\frac{1}{4}$ of the real dimensions; a diagram of part of the wheel on a somewhat larger scale is added, to show the form of the vanes.

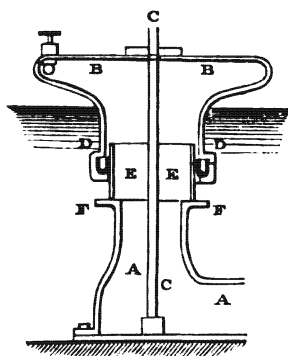

Fig. 77.

A A is the wheel, B its shaft. The wheel occupies the *wheel chamber*, which is the central part of the upper division of a strong

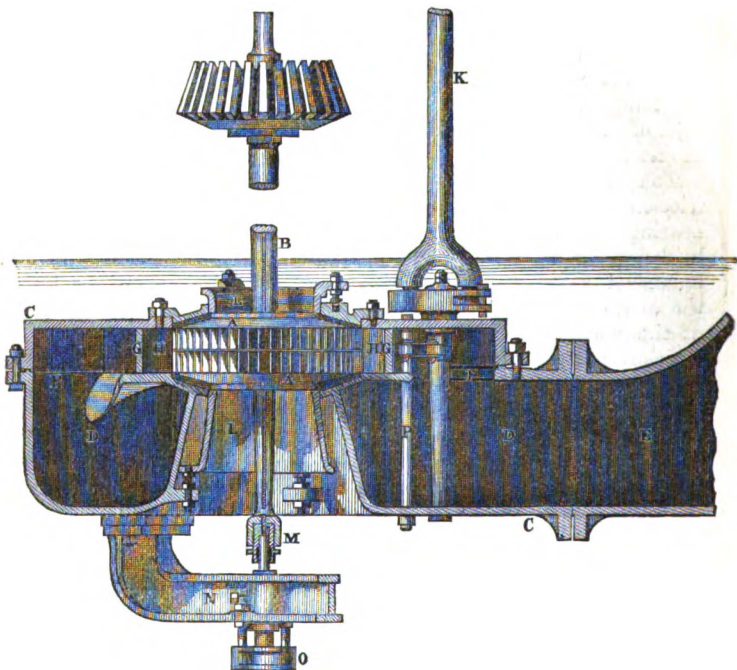

Fig. 78.

cast iron case C C. The lower division D D of that case is called the *supply chamber*; it receives the water from the supply pipe E, and delivers it through four large openings marked F, into the *guide blade chamber*, which is the outer part of the upper division of the case. There are four guide blades marked G; the figure of each of them, near the wheel, is nearly that of a quadrant of the same radius with the wheel; beyond the quadrantal portion they are sometimes straight, and sometimes curved the reverse way. The four openings marked H, between the guide blades, regulate, by their area (O₁, Article 178), the volume of water supplied per second, and consequently the power of the wheel. To vary these openings, the guide blades are moveable about gudgeons near their points, seen as small circles in fig. 79: these gudgeons are sunk in the roof and floor of the chamber, and do not impede the flow of

the water. The guide blades are connected by a set of levers and links with a spindle K, by turning which, they can all four be

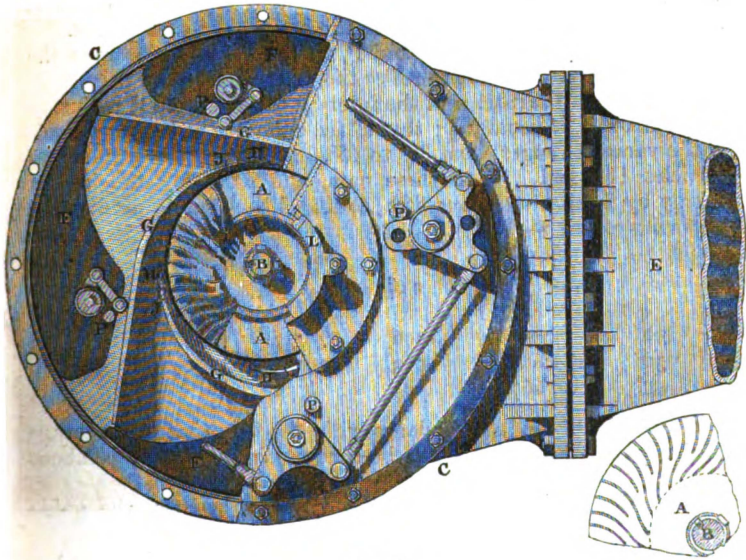

Fig. 79.

shifted at once, so as to make any required angle (α) with the circumference of the wheel. (The advantages of this mode of regulation have already been stated in Article 179.)

The water, after passing through the passages between the vanes of the wheel, is delivered into the central opening of the wheel, as nearly as possible without any whirling motion left; it then escapes at once upwards and downwards through the two outlets of that opening. LL are two pieces called *joint rings*, fitted to those central outlets, and adjusted by means of studs and nuts, so as to come as close to the wheel as is possible without rubbing against it, in order to prevent leaking of water between the wheel and its case.

The lower end of the shaft passes through an oil-tight stuffing box into the pivot box M, and terminates in an inverted cup, containing a concave brass disc, which rests on the convex top of a fixed steel pin. The pin is fixed in a bridge N, and is capable of being set to the proper level by means of a cross bridge O, with adjusting screws. The cup of the pivot is supplied with oil through a small pipe sunk in a groove in the shaft B.

P

Mr. Thomson states in a note, that he has found that the pivots last well without oil, by simply admitting the free access of the water. Of late, lignum-vitæ, set endwise, and kept constantly wet, has been found a good material for the bearings of such pivots.

Four vertical tie bolts, marked P, tie the top and bottom of the case together, to enable it to resist the pressure of the water.

The value of the ratio n of the internal to the external radius, in those turbines, is usually $\frac{1}{2}$; that of the obliquity of the inner ends of the vanes β , ranges from 30° to 45° . Applying the formulæ of Articles 175 and 177 to these data, and assuming the loss of energy by friction to be one-fifth, so that $1 - k'' = \cdot 8$, we find the following results:—

β	$z_1 = \frac{a_1 r}{\sqrt{2 g h}}$	$2 z_1^2$	$1 \cdot 6 z_1^2$	}	Efficiency...(1.)
30°	$\cdot 693$	$\cdot 96$	$\cdot 77$		
36°	$\cdot 685$	$\cdot 93$	$\cdot 75$		
45°	$\cdot 667$	$\cdot 89$	$\cdot 71$		

These results are in accordance with the fact, that the average efficiency of vortex wheels has been found in practice to be about $\cdot 75$.

The velocity of the water in the openings between the guide blades is

$$v_1 \sec \alpha = z_1 \sec \alpha \sqrt{2 g h_1}; \dots \dots \dots (2.)$$

the effective area of those passages (taking $c = \cdot 9$ for the co-efficient of contraction) is very nearly

$$O_1 = \cdot 9 \times 2 \pi r b \cdot \sin \alpha; \dots \dots \dots (3.)$$

where b is the clear depth of the guide blade chamber; hence the volume of flow is

$$Q = O_1 v_1 \sec \alpha = \cdot 9 \times 2 \pi r b \cdot \tan \alpha; \dots \dots \dots (4.)$$

and the angle α of obliquity of the guide blades required to deliver a given flow per second, may be computed by the formula

$$\tan \alpha = \frac{10 Q}{9 \times 2 \pi r b}; \dots \dots \dots (5.)$$

but care should be taken to make r and b such, that $\tan \alpha$ during the ordinary working of the wheel shall deviate as little as possible from $n \tan \beta$; that is, with the usual proportions, $\frac{1}{2} \tan \beta$. The reasons for this are given in Article 173.

The crowns of the wheel shown in the figure approximate to the form recommended in Article 172.

CHAPTER VII.

OF FLUID-ON-FLUID IMPULSE ENGINES.

186. **Introductory Explanations.**—In the engines to which the present Chapter relates, motion against resistance is produced in one portion of fluid by the direct impulse of another portion of fluid, the driven portion of the fluid doing the duty of a float board, or vane.

Such machines may be divided into two classes—

I. Those in which the energy of a mass of liquid descending from a small height is made to raise a small portion of that mass to a greater height: this class consists of the "*Hydraulic Ram.*"

II. Those in which a stream of fluid moving at first with a certain velocity, drives and carries along with it an additional stream, the two streams finally mingling and moving together with a velocity less than that of the driving stream. This class comprehends the jet pump, the water blower, and the blast pipe.

187. **Hydraulic Ram.**—This machine, a well known invention of Montgolfier's, is used where a considerable flow of water with a moderate fall is available, to raise a small portion of that flow to a height exceeding that of the fall.

To supply it with water, a weir is to be erected across a stream, so as to form a pond, as if for a water wheel. From the lower part of that pond comes the supply pipe A, fig. 80. In the course of that pipe is the waste valve chamber B, containing a conical clack which opens downwards, and which is large enough to let the flow of the supply pipe pass without contraction. D is the tail race, for carrying away the water which escapes from the waste valve.

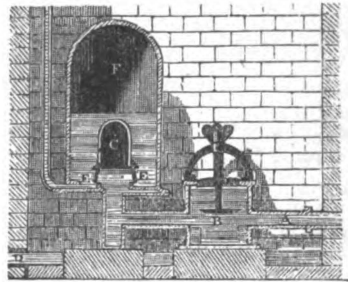

Fig. 80.

At the end of the supply pipe is a small air vessel C, for diminishing the violence of shocks.

E are clacks opening from the supply pipe into the larger and outer air vessel F, from the bottom of which the discharge pipe is seen to rise, for the purpose of conveying a certain portion of the water to the required elevation.

A small relief clack opens from a passage communicating with the external air, into the inner air vessel. When the quantity of air in that vessel becomes deficient, periods occur in the course of the action of the machine, when the pressure within the vessel falls below that of the atmosphere; and then the relief clack admits a small quantity of air, to supply the loss caused by its diffusion in the water.

The following is the mode of operation of the hydraulic ram :—

Suppose the waste clack to have been shut, by pressure from within, and to fall suddenly open, owing to the diminution of that pressure. The water begins to flow from the reservoir through the supply pipe and out at the waste clack, with a gradually increasing velocity. At length that velocity reaches a maximum, being the velocity of steady flow which the head in the pond is capable of maintaining through the supply pipe and its outlet. The weight and load of the waste clack are so adjusted, that the impulse of the current upon it with this velocity raises it, and causes it suddenly to shut.

Thus the current through the supply pipe is abruptly checked. The water between the reservoir and the waste clack still tends to advance, by its momentum, and compresses the water between the waste clack chamber and the air vessels, and the air in the smaller air vessel. In an inappreciably short time the pressure becomes a little more intense than that in the outer air vessel; that is, than the pressure due to the length to which a portion of the water is to be lifted. Then the clacks E open, and water passes into the air vessel against the higher pressure, and thence up the discharge pipe, until the energy of the mass of water in the supply pipe is so far expended, that its pressure can no longer keep the clacks E open, nor the waste clack shut. Then the clacks E shut, the waste clack opens, and the operation begins anew.

The following proportions for hydraulic rams have been found to answer in practice :—

Let h be the height above the pond to which a portion of the water is to be raised ;

H , the height of top water in the pond above the outlet of the waste clack ;

L , the length of the supply pipe, from the pond to the waste clack ;

D , its diameter ; then

$$H = \frac{h}{20} ; L = 2.8 H = 0.14 h ; D = \frac{H}{10} = \frac{h}{200} ; \dots (1.)$$

Let Q be the whole supply of water in cubic feet per second, of which q is lifted to the height h above the pond, and $Q - q$ runs to waste at the depth H below the pond. Then the efficiency of the

ram has been found by experience to have the following average value :—

$$\frac{q h}{Q H} = \frac{2}{3} \text{ nearly.....(2.)}$$

187 A. **Jet Pump.**—This machine works by means of the tendency of a stream or jet of fluid to drive or carry contiguous particles of fluid along with it. The general nature of its construction is represented by fig. 81. A is the jet pipe, by which a sufficient supply of water is brought from an elevated source ; B is the suction pipe, by which another portion of water is drawn from a low level. C is the contracted throat of the passage, at or a little behind which is the nozzle of the jet ; D is the trumpet-mouthed spout in which the jet mingles with the stream from below, carries it forward, and causes a diminution of pressure behind the nozzle, and in the suction pipe, sufficient to make the water rise.

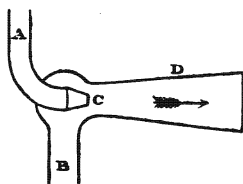

Fig. 81.

Contrivances depending on the same principle with this machine have long been known ; but the water jet pump, in its present form, was invented by Professor James Thomson, and first described in the Report of the British Association for 1852. In the report of that body for 1853, Mr. Thomson published the results of some experiments on a small scale as to the efficiency of the jet pump. The greatest efficiency was found to take place when the depth from which the water was drawn by the suction pipe was about *nine-tenths* of the height from which the water fell to form the jet ; the flow up the suction pipe being in that case about *one-fifth* of that of the jet, and the efficiency, consequently,

$$\frac{9}{10} \times \frac{1}{5} = 0.18.$$

This is but a low efficiency ; but it is probable that it may be increased by improvements in the proportions of the machine.

The **WATER BLOWER**, in which a shower of water, falling in drops within a vertical cylinder with holes in its sides, carries a current of air down with it, which is expelled through a nozzle near the bottom of the cylinder, is a machine on the same principle with the jet pump. Its efficiency is said to be about 0.15.

The **BLAST PIPE**, the most important of George Stephenson's improvements in the locomotive engine, is an example of the same kind of action, which will be mentioned again in its proper place : so also is Mr. Gurney's **STEAM JET VENTILATOR** for mines.

CHAPTER VIII.

OF WINDMILLS.

188. **General Description.**—The energy of the wind, in driving a windmill, is exerted upon a wheel, or fan, consisting of four or five vanes called *sails*, radiating from a horizontal or slightly inclined shaft called the *wind shaft*, which is kept always turned endwise towards the wind.

The inclination of the wind shaft to the horizon is from 5° to 15° ; its object is to make the sails revolve clear of the tower or other building which contains the mill.

There are two methods of enabling the wheel always to face the wind. In a "*post mill*," the whole machine, with its framework and casing, turns upon a pivot on the top of a vertical post, and is shifted when the wind changes, by means of a long horizontal lever. In a "*tower mill*," or "*smock mill*," there is a fixed tower with a rotating cap; the cap supports the wind shaft, and is turned to the quarter from which the wind blows, by apparatus which is sometimes controlled by hand, but oftener self-acting. The remainder of the mechanism is supported by a stationary frame.

The obliquity of a windmill sail, or the angle which it makes with its plane of revolution, is called its *weather*.

Fig. 82 is a front view of the frame or skeleton of a common windmill sail. C is the end of the wind shaft, from $1\frac{1}{2}$ foot to 2 feet square, if of wood; from 6 inches to 9 inches in diameter, if of iron. C A B is the arm, or *whip*, of one of the sails, usually from 30 feet to 40 feet long, 8 inches to 10 inches square at the inner end, and about $\frac{3}{4}$ of these dimensions at the outer end. From A D to B E are the *bars* of the sail—slender wooden rods, from 15 to 18 inches apart. A B is the leading or foremost edge of the sail, which in the present example lies along the whip itself: in some sails, a small portion, called the *leading sail*, extends before the whip.

Fig. 83 shows the frame of the sail, as seen edgeways; fig. 84 is a diagram of the sail, as seen endways, in which O P and O Q show the positions of the bars at the top and at the inner end of the sail respectively: these two figures show how the *weather* gradually diminishes from the inner end of the sail to the tip, for reasons which will appear in the next Article.

The leading sail, when there is one, is usually covered with thin boards; the main body of the sail, either with canvas, or with a number of narrow boards called *valves*, capable of being adjusted to different angles, in a manner to be afterwards described.

189. **General Principles.**—The reduction of the art of designing windmills to general principles is almost wholly due to an experimental investigation by Smeaton, communicated to the Royal Society in 1759, and republished in Tredgold's *Tracts on Hydraulics*.

The general principles established by Smeaton are to a certain extent capable of being expressed by a proper adaptation of the formulæ of Article 144, Case V., equations 49 to 15—a term being subtracted to represent loss of energy by friction between the air and the sail, as follows:—

Let *D* denote the weight of a cubic foot of air;

Q, the volume of air which acts on the sail, or part of a sail, under consideration, in cubic feet per second;

v, the velocity of the wind, in feet per second.

If *s* be taken to represent the sectional area of the cylinder, or annular cylinder of wind through which the sail, or part of a sail, in question sweeps in the course of its revolution, we may put

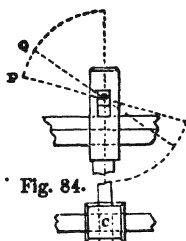

Fig. 84.

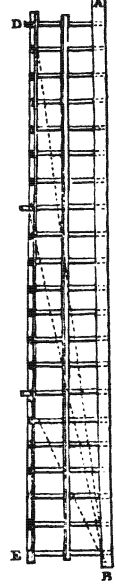

Fig. 82.

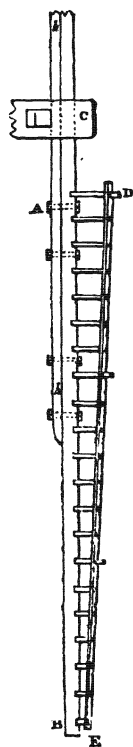

Fig. 83.

$$Q = c v s ; \dots\dots\dots(1.)$$

where *c* is a co-efficient to be found empirically.

As it is difficult, if not impossible, in the present state of our knowledge, to distinguish between that factor in the power of a windmill which depends on the quantity of wind that acts upon it,

and that factor which expresses the diminution of efficiency by the friction of the shaft, it is best to make the co-efficient c , in the above equation, comprehend the allowance for that friction: and this being understood, it appears from experimental data by Smeaton, to be afterwards referred to, that for a windmill with four sails proportioned in the best manner, if s be taken for the sectional area of the whole cylinder of wind in which the wheel rotates,

$$c = 0.75 \text{ nearly} \dots \dots \dots (2.)$$

The friction of the air will be separately allowed for.

Let ζ denote the weather of the sail; then because the direction of motion of each point in the sail is perpendicular to that of the wind, we must make, in the formulæ of Article 144,

$$\delta = 90^\circ - \zeta, \text{ and } \cos \delta = \sin \zeta.$$

Consider a narrow band of a sail at a given distance from the axis, and let u be its velocity.

The whole velocity of the wind relatively to this band is $\sqrt{v^2 + u^2}$; and as it is probable that the energy lost through the friction of the air is proportional to the square of that velocity, we may put for that lost energy, per pound of the acting stream of wind,

$$f \cdot \frac{v^2 + u^2}{2g} \dots \dots \dots (3.)$$

f being a co-efficient of friction, to be found empirically.

From data by Smeaton, to be afterwards referred to, it appears that the probable value of this co-efficient for the best sails is

$$f = 0.016 \dots \dots \dots (3 \text{ A})$$

Then modifying the symbols in equation 50, as already described, and deducting the loss of energy by aerial friction, we find for the useful work per second done by the action of the wind on the band, or bands of sail, that sweep through the stream of air whose sectional area is s ,

$$\begin{aligned} R u &= c D s v \cdot \frac{1}{2g} \left\{ 2 u v \cdot \cos \zeta \sin \zeta - u^2 (2 \sin^2 \zeta + f) - f v^2 \right\} \\ &= c D s v \cdot \frac{1}{2g} \left\{ u v \cdot \sin 2 \zeta - u^2 (1 - \cos 2 \zeta + f) - f v^2 \right\} \end{aligned} \quad (4.)$$

Dividing this by $\frac{D s v^3}{2g}$, the whole energy per second of the

stream of wind, we find for the *efficiency* of the action of that stream

$$\frac{R u}{D s \frac{v^3}{2g}} = c \left\{ \frac{u}{v} \sin 2 \zeta - \frac{u^2}{v^2} (1 - \cos 2 \zeta + f) - f \right\} \dots (5.)$$

The ratio of the speed of greatest efficiency for a given *weather* ζ , to the speed of the wind, is

$$\frac{u_1}{v} = \frac{\sin 2 \zeta}{2 (1 - \cos 2 \zeta + f)} \dots \dots \dots (6.)$$

The efficiency corresponding to that speed is

$$c \left\{ \frac{\sin^2 2 \zeta}{4 (1 - \cos 2 \zeta + f)} - f \right\} ; \dots \dots \dots (7.)$$

and the useful work corresponding to that efficiency

$$R_1 u_1 = c D s \cdot \frac{v^3}{2g} \left\{ \frac{\sin^2 2 \zeta}{4 (1 - \cos 2 \zeta + f)} - f \right\} \dots \dots \dots (8.)$$

The following are some examples of the results of these formulæ, taking, as already stated, $f = 0.016$, $c = 0.75$:—

ζ	$\frac{u_1}{v}$	$\frac{R_1 u_1}{D s \frac{v^3}{2g}}$	
7°	2.63	0.24	}
13°	1.86	0.29	
19°	1.41	0.31	

..... (9.)

It will afterwards be shown within what limits these formulæ are applicable.

190. The **Best Form and Proportions of Sails**, as determined experimentally by Smeaton, are as follows :—

In fig. 85, A is the wind shaft; A C, the whip of one sail; B D E C, the main or following division of the sail, which is rectangular; B F C, the leading division of the sail, which is triangular.

The following are the best proportions :—

$$\left. \begin{aligned} \overline{A B} &= \frac{1}{6} \overline{A C}; \quad \overline{B C} = \frac{5}{6} \overline{A C}; \\ \overline{B D} &= \overline{C E} = \frac{1}{5} \overline{A C}; \quad \overline{C F} = \frac{2}{15} \overline{A C} \end{aligned} \right\} \dots \dots \dots (1.)$$

The following are the best values for the *angle of weather* at different distances from the axis :—

Distance in <i>sixths</i> } of $\overline{A B}$,..... }	1	2	3	4	5	6	}	(2.)
	(first bar)					(tip)		
Weather, ζ ,.....	18°	19°	18°	16°	12°½	7°		

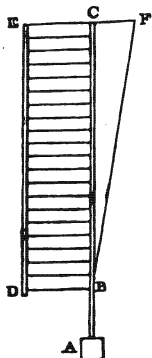

Fig. 85.

191. The **Best Speed** for the *tips of the sails*, weathered as above, was found by Smeaton to be about 2.6 times the velocity of the wind; that is,

$$\text{for } \zeta = 7^\circ, u_1 = 2.6 v \dots \dots \dots (1.)$$

It is from this experimental result that the value of the co-efficient of friction employed in Article 189 has been deduced, viz, $f = 0.016$.

The result computed in the same Article, that for $\zeta = 19^\circ, \frac{u_1}{v} = 1.41$, indicates that 19° is the proper angle of weather for a point about the middle of the sail; which is confirmed by experiment.

The application of the formulæ of that Article to all parts of the sail would give it a slightly convex surface; but Smeaton found a slightly concave surface (as indicated by Table 2, Article 190) to be somewhat more efficient; upon which he observes, "that when the wind falls upon a concave surface, it is an advantage to the power of the whole, though every part, taken separately, should not be disposed to the best advantage."

It further appears, that the formulæ should not be applied between the middle and the inner end of the sail, it being better to preserve nearly the same angle of weather throughout that part of it.

192. **Power and Efficiency.**—The effective power of a windmill, as Smeaton ascertained by experiment, and as equations 4 and 8 of Article 189 indicate, varies as s , the *sectional area of the acting stream of wind*; that is, for similar wheels, as the *squares of the radii*.

The value 0.75, assigned to the multiplier c in Article 189, is founded on the fact ascertained by Smeaton, that the *effective power of a windmill with sails of the best form, and about 15½ feet radius, with a breeze of 13 feet per second, is about one horse-power*. In the computations founded on that fact, the *mean angle of weather* ζ is made = 13° , and $f = 0.016$ as before. Then making the radius $\overline{A B} = r$, and the area of the cylinder of wind,

$$s = \pi r^2,$$

equation 8 of Article 189 becomes as follows:—

$$R_1 u_1 = 0.29 \cdot \frac{D v^3}{2g} \cdot \pi r^2; \dots \dots \dots (1.)$$

being the effective power at the best speed, when the tips of the sails move at 2.6 times the speed of the wind.

To find the effective power at any speed, equation 4 is referred to, which, when $\zeta = 13^\circ$, becomes—

$$R u = 0.75 \frac{D v}{2g} \cdot \pi r^2 \left\{ 0.438 u v - 0.117 u^2 - 0.016 v^2 \right\} (2.)$$

The value of D ,—the weight of a cubic foot of air,—may be found exactly by means of Tables II. and III. at the end of this volume; but taking it on an average at 0.075 lb., the above formulæ become,—

$$R_1 u_1 = 0.022 \frac{v^3}{2g} \cdot \pi r^2; \dots\dots\dots (1 \text{ A.})$$

$$R u = 0.056 \cdot \frac{v}{2g} \cdot \pi r^2 \left\{ 0.438 u v - 0.117 u^2 - 0.016 v^2 \right\} (2 \text{ A.})$$

From equation 1 it appears that a windmill of the best form and proportions, with the tips of the sails moving at 2.6 times the speed of the breeze, has an effective power equal to $\frac{1}{157}$ of the actual energy of the cylinder of wind which passes it in a second.

193. **Tower Mill.—Self-Acting Cap.**—Fig. 86 is a vertical section, and fig. 87 a horizontal section, of the top of a tower mill, with its self-acting cap.

A A A is the tower; B B B the cap, whose lower edge is an iron ring, resting on a circle of rollers which rest on another iron ring on the top of the tower, and are kept at their proper distance apart by an intermediate ring R, in which their axes have bearings. a, a, a are blocks with horizontal guide rollers.

C is a circular rack fixed to the top of the tower.

S is the wind shaft, carrying a bevel wheel D, which drives a bevel wheel on the upright shaft N, through which motion is given to the machinery of the mill.

From the back of the cap projects the frame L L, carrying the fan M, which through a train of wheelwork marked b and $c c$, drives the pinion f , which works in the rack c , already mentioned. When the wind wheel faces the wind, the fan is turned edgewise towards the wind, and remains at rest. So soon as the wind changes its direction, it makes the fan rotate in one direction or another, and so drives the pinion f , which makes the cap turn until the wind wheel again faces the wind.

The bevel wheel D on the wind shaft is often used also as a *brake-wheel*, its rim being encircled by a flexible brake (Article 49).

194. **Reefing, or Regulation of Sails.**—The old method of covering a windmill sail was with a sheet of canvas, of which a greater or less extent could be spread according to the strength of the wind.

Various methods have been invented for varying the surface exposed to the wind while the mill is in motion, such as rollers, upon which a greater or less extent of the canvas can be rolled up;

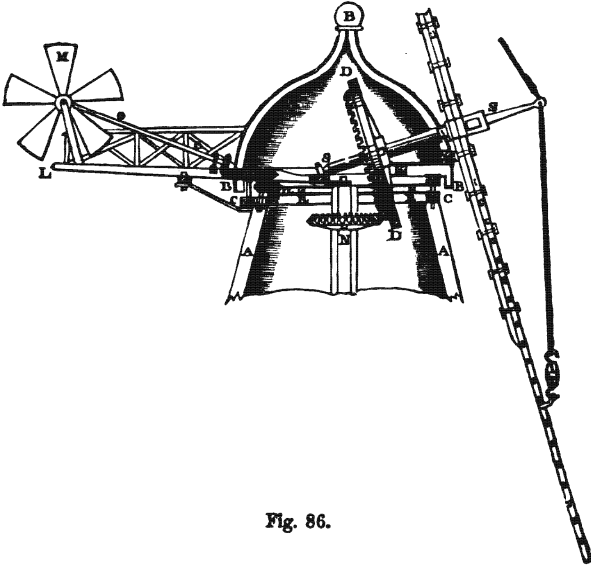

Fig. 86.

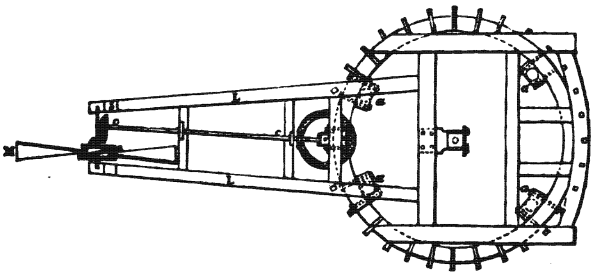

Fig. 87.

boards furling by sliding behind each other like the sticks of a fan; and boards turning on axes into different positions, like the bars of a Venetian blind. The last method, the invention of Sir William Cubitt, is illustrated in figs. 88 and 89. Fig. 88 is a side view,

fig. 89, a front view. A is the wind shaft, which is hollow; B C, a rod passing through it; C, a swivel, to enable the foremost end of the shaft; C D, the hinder end of the rod, which is a toothed rack, working with the pinion E; F, a drum on the axis of that pinion; G, a cord wound on it, from which hangs a weight W; I, a guide roller for the rack.

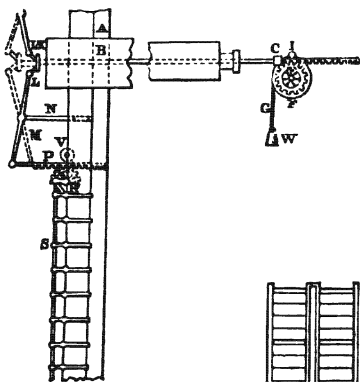

Fig. 88.

K is the head of the rod B C, connected by links L with the levers M, which turn on bearers carried by the projecting brackets N. P is a rack; V, a guide roller; Q, a pinion; R, a lever; S, a rod, connected with all the levers for moving the *valves*, or transverse boards, which, when shut, or turned flatwise to the wind, fill the spaces between the bars of the sail, and make a continuous flat surface; when opened, or turned edgewise to the wind, allow it to pass through with little action on the sail; and when turned into intermediate positions, give the same effect with a greater or less surface of sail. Each sail has similar apparatus.

The axes on which the valves turn are placed nearer to one edge than to the other, so that the pressure of the wind tends to open them. It is opposed by the weight W, which tends to close them. The valves adjust their own obliquity, so that the pressure of the wind balances the weight W; and thus the *effort* of the wind on the sails is maintained nearly constant through all variations of its speed.

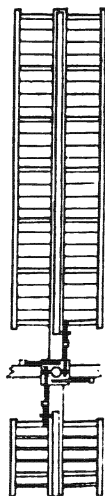

Fig. 89.

PART III

OF STEAM AND OTHER HEAT ENGINES.

195. **Nature and Division of the Subject.**—It is believed to have been first remarked by George Stephenson, that the original source of the power of heat engines is the sun, whose beams furnish the energy that enables vegetables to decompose carbonic acid, and so to form a store of carbon and of its combustible compounds, afterwards used as fuel. The combination of that fuel with oxygen in furnaces produces the state of heat, which being communicated to some fluid, such as water, causes it to exert an augmented pressure, and occupy an increased volume; and those changes are made available for the driving of mechanism.

According to a speculation originated by Mr. Waterston, and modified and developed by Professor William Thomson, the heat of the sun is produced by the fall of a shower of matter into it; so that the original source of the power of heat is gravitation.

In the present treatise we are concerned with those operations only in the obtaining of mechanical energy by means of heat, which are performed after the fuel has been procured in a state fit for use.

The present part of this treatise consists of two main divisions; the first treating of those laws of the relations amongst the phenomena of chemical combination, heat and mechanical energy, upon which the work and efficiency of heat engines depend: the second, of the structure and operation of those engines.

The former of those main divisions consists of three subdivisions, the first treating of relations amongst the phenomena of heat themselves; the second, of combustion, or the production of heat by chemical action; and the third, of the relations between heat and mechanical energy, whose principles form the science of **THERMODYNAMICS**.

The latter of the two main divisions consists of two subdivisions, the first relating to the apparatus by which heat is obtained from burning fuel, and communicated to a fluid, which apparatus, in the steam engine, comprehends the furnace and boiler; the second, relating to the apparatus by which the heated fluid is made to perform work by driving mechanism, being the "*engine*" proper, as distinguished from the furnace and boiler.

CHAPTER I.

OF RELATIONS AMONGST THE PHENOMENA OF HEAT.

196. **Heat Defined and Described.**—The word “HEAT” is used in two senses—

I. A certain class of sensations.

II. That condition of bodies which consists in the capacity for producing such sensations.

It is in the second of those senses that the word will be employed in this treatise.

The condition called heat has other properties besides that by which it has been defined. Of these the principal are as follows:—

I. Heat is *transferrible* from one body to another; that is, one body can heat another by becoming less hot itself; and the tendencies to effect that transfer are capable of being compared together by means of a scale of quantities on which they depend, called *temperatures*.

II. The transfer of the condition of heat between two bodies tends to bring them to a state called that of *uniform temperature*, at which the transfer ceases.

III. The quantities called temperatures are accompanied in each body by certain conditions as to the relations between density and elasticity; the general law being, that the hotter a body is, the less is its *elasticity of figure*, or tendency to preserve a definite form and arrangement of parts, and the greater its *elasticity of volume*; that is, its tendency, if solid or liquid, to preserve a definite volume, and if gaseous, to expand indefinitely.

IV. The condition of heat is a condition of ENERGY; that is, of capacity to effect changes. One of those changes has already been mentioned under the head I., viz., the change in the condition of heat of bodies which are unequally hot, tending to bring them to uniformity of temperature. Amongst other of those changes are changes of density, changes of elasticity, chemical, electrical, and magnetic changes.

V. The condition of heat, considered as a kind of energy, is capable of being indirectly measured, so as to be expressed as a quantity, by means of one or other of the directly measurable effects which it produces.

VI. When the condition of heat is thus expressed as a quantity,

it is found to be subject, like other forms of energy (mechanical energy, for example,) to a law of *conservation*; that is, if in any system of bodies, no heat is expended or produced through changes other than changes of temperature, then the total quantity of heat in the system cannot be changed by the mutual actions of the bodies; but what one body loses, another gains; and if there are changes other than changes of temperature, then if by those changes the total heat of the system is changed in amount, that change is compensated exactly by an opposite change in some other form of energy.

Although the present chapter treats specially of relations amongst the phenomena of heat, yet it is impossible to explain these relations without occasionally referring to relations between phenomena of heat, and other classes of phenomena, as has already been done in the preceding general description of heat.

The remainder of this chapter is divided into three sections.

The first relates to the measurement of *temperature*, and to the phenomena with which particular temperatures are accompanied.

The second relates to the measurement and comparison of *quantities of heat*, whether such as are lost by one body and gained by another during changes of temperature, or such as appear and disappear during changes of other kinds.

The third relates to the rapidity with which the *transfer of heat* takes place under various circumstances.

SECTION 1.—Of Temperatures, and Phenomena depending on them.

197. **Equal Temperatures.**—Two bodies are said to be at *equal temperatures*, or at the *same temperature*, when there is no tendency to the transfer of heat from either to the other.

198. **Fixed Temperatures**, or standard temperatures, are temperatures identified by means of certain phenomena which occur at them.

The most important and useful of fixed temperatures is that of the **MELTING OF ICE** under the average atmospheric pressure. This pressure is specified for the sake of precision; for although the variation of the temperature of melting ice with variations of pressure is exceedingly small, it is still appreciable.

Next in importance and utility is the **BOILING POINT OF PURE WATER UNDER THE AVERAGE ATMOSPHERIC PRESSURE OF**

14.7 lbs. on the square inch, or
 2116.4 lbs. on the square foot, or
 29.922 inches of a vertical column of mercury,

the mercury being at the temperature of melting ice.

There are many other phenomena besides the melting of ice and boiling of water under the mean atmospheric pressure, which serve to identify fixed temperatures; but the two phenomena which have been specified are chosen, because of the precision with which they can be observed, for the purpose of fixing the standard temperatures on the scales of THERMOMETERS, or instruments for measuring temperature.

199. **Degrees of Temperature—Perfect Gas Thermometer.**—The two standard points of the scale of temperatures having been found, it is next requisite to express all other temperatures by means of a scale of degrees, and fractions of a degree; which scale is to be graduated according to the magnitude of some directly measurable quantity depending on temperature.

The quantity chosen for that purpose is the product of the pressure and volume of a given mass of a perfect gas.

A PERFECT GAS is a substance in such a condition, that the total pressure exerted by any number of portions of it, at a given temperature, against the sides of a vessel in which they are enclosed, is the sum of the pressures which each such portion would exert if enclosed in the vessel separately at the same temperature; in other words, a substance in which the tendency to expand of each appreciable mass, how small soever, that is diffused through a given space, is a property independent of the presence of other masses within the same space. Absolutely perfect gases are not found in nature; every gas approximates more closely to the condition of a perfect gas the more it is heated and rarefied; and air is sufficiently near to the condition of a perfect gas for thermometric purposes.

Let v_0 denote the volume of a given weight of any perfect gas under a pressure of the intensity p_0 , at the temperature of melting ice, and $p_0 v_0$ the product of those factors;—a quantity whose value in foot-pounds, for one pound avoirdupois of air and other gases, is given in Table II., at the end of this volume.

Let $p_1 v_1$ be the corresponding product for the temperature of water boiling under the pressure of one atmosphere.

Then it is known from the experiments of M. Regnault and Mr. Rudberg, that these two products bear to each other the following proportion:—

$$\frac{p_1 v_1}{p_0 v_0} = 1.365 \dots \dots \dots (1.)$$

Now let T_0, T_1 , denote respectively the temperatures of melting ice and boiling water under the pressure of one atmosphere, in degrees of the scale of a perfect gas thermometer, the intervals upon which scale correspond with the intervals between the values of the ratio $p v \div p_0 v_0$.

Let T be any third temperature, and $p v$ the corresponding product of the pressure and volume of the gas.

Then because the interval $T_1 - T_0$ corresponds to the difference $\frac{p_1 v_1 - p_0 v_0}{p_0 v_0} = 0.365$, it is clear that the interval $T - T_0$, corresponding to the difference $\frac{p v - p_0 v_0}{p_0 v_0}$, must have the following value:—

$$T - T_0 = \frac{T_1 - T_0}{0.365} \cdot \frac{p v - p_0 v_0}{p_0 v_0}; \dots\dots\dots(2.)$$

and this equation expresses the relation between *intervals of temperature*, and differences of the product $p v$.

200. **Different Thermometric Scales.**—The number of degrees $T_1 - T_0$ into which the interval between the two standard temperatures is divided, and the number of degrees, T_0 , between the zero of the scale and the temperature of melting ice, are arbitrary.

On *Réaumur's scale*, the zero is the temperature of melting ice, and $T_1 - T_0 = 80^\circ$; therefore,

$$T_0 = 0^\circ; T_1 = 80^\circ;$$

$$T - T_0 = \frac{80^\circ}{0.365} \cdot \frac{p v - p_0 v_0}{p_0 v_0} = 219^\circ.2 \frac{p v - p_0 v_0}{p_0 v_0} \dots(1.)$$

On the *Centigrade scale*, used in France, and over most of the continent of Europe, the zero is the temperature of melting ice, and $T_1 - T_0 = 100^\circ$; therefore,

$$T_0 = 0^\circ; T_1 = 100^\circ;$$

$$T - T_0 = \frac{100^\circ}{0.365} \cdot \frac{p v - p_0 v_0}{p_0 v_0} = 274^\circ \frac{p v - p_0 v_0}{p_0 v_0} \dots(2.)$$

On *Fahrenheit's scale*, used in Britain and America, the zero is an arbitrary point, 32° below the temperature of melting ice; $T_1 - T_0 = 180^\circ$; and therefore,

$$T_0 = 32^\circ; T_1 = 212^\circ;$$

$$T - T_0 = \frac{180^\circ}{0.365} \cdot \frac{p v - p_0 v_0}{p_0 v_0} = 493^\circ.2 \frac{p v - p_0 v_0}{p_0 v_0} \dots(3.)$$

In the present treatise, Fahrenheit's scale is used when no other is specified.

On all thermometric scales, temperatures below zero are reckoned downwards, and distinguished by having the negative sign prefixed.

201. **Absolute Zero—Absolute Temperature.**—There is a temperature which is fixed by reasoning, although no opportunity ever occurs of observing it; and that is, the temperature corresponding to the disappearance of gaseous elasticity, at which $p v = 0$.

This is called the **ABSOLUTE ZERO** of the perfect gas thermometer. By reckoning temperatures from it, the laws of all the phenomena which depend on temperature are found to be expressed more simply than by reckoning from any ordinary zero. It is therefore the most suitable zero for purposes of scientific reasoning. For the purpose of recording observations, the ordinary zeros are more convenient, because of the remoteness of the absolute zero from any temperature which is ever observed.

Temperatures reckoned from the absolute zero are called **ABSOLUTE TEMPERATURES**. In this treatise, they will be denoted by the symbol τ .

Let τ_0 be the absolute temperature of melting ice; and τ_1 that of boiling water, under the pressure of one atmosphere.

Let τ be any third absolute temperature.

Then

$$\tau_0 = \frac{T_1 - T_0}{0.365}; \dots\dots\dots(1.)$$

$$\tau_1 = 1.365 \tau_0; \dots\dots\dots(2.)$$

$$\tau = \tau_0 \cdot \frac{p v}{p_0 v_0} \dots\dots\dots(3.)$$

These formulæ become—

for *Réaumur's scale*,

$$\left. \begin{aligned} \tau_0 &= 219^{\circ}.2; \tau_1 = 299^{\circ}.2; \tau = 219^{\circ}.2 \frac{p v}{p_0 v_0} \\ &= T + 219^{\circ}.2; \end{aligned} \right\} \dots\dots(4.)$$

for the *Centigrade scale*,

$$\tau_0 = 274^{\circ}; \tau_1 = 374^{\circ}; \tau = 274^{\circ} \frac{p v}{p_0 v_0} = T + 274^{\circ}; \dots(5.)$$

for *Fahrenheit's scale*,

$$\left. \begin{aligned} \tau &= 493^{\circ}.2; \tau_1 = 673^{\circ}.2; \tau = 493^{\circ}.2 \frac{p v}{p_0 v_0} \\ &= T + 461^{\circ}.2; \end{aligned} \right\} \dots(6.)$$

and the positions of the absolute zero *on the ordinary scales* are,

$$\left. \begin{aligned} \text{on Réaumur's scale,} & \quad - 219^{\circ}.2, \\ \text{on the Centigrade scale,} & \quad - 274^{\circ}, \\ \text{on Fahrenheit's scale,} & \quad - 461^{\circ}.2. \end{aligned} \right\} \dots\dots\dots(7.)$$

Table III., at the end of the volume, shows a series of ordinary temperatures on the Centigrade and Fahrenheit's scales, with the corresponding absolute temperatures, and the corresponding values of $p v \div p_0 v_0$.

202. **Expansion and Elasticity of Gases.**—A gas sensibly perfect has the law of its expansion and elasticity expressed as follows:—

$$\frac{p v}{p_0 v_0} = \frac{\tau}{\tau_0}; \dots \dots \dots (1)$$

and the results of this formula are given in Table III., already referred to.

The *co-efficient of expansion* of a perfect gas, being the increase of volume under constant pressure, for one degree of rise of temperature, of so much of the gas as fills unity of space at the temperature of melting ice, is the reciprocal of the absolute temperature of melting ice, or,

$$\frac{1}{493.2} = 0.0020276 \text{ per degree of Fahrenheit.}$$

This is a theoretical limit to which the co-efficients of expansion of gases approximate as their densities diminish and temperatures increase. Their actual co-efficients of expansion exceed that limit by small quantities depending on the nature, density, and temperature of the gas.

A hypothesis called that of "molecular vortices," referred to in the historical sketch prefixed to this work, led to the conclusion, in the case of *imperfect gases*, that the law of their expansion and elasticity would be found to be expressed approximately by an equation of the form,

$$\frac{p v}{p_0 v_0} = \frac{\tau}{\tau_0} - A_0 - \frac{A_1}{\tau} - \frac{A_2}{\tau^2} - \&c. \dots \dots \dots (2)$$

$A_0, A_1, \&c.$, being functions of the density $\frac{1}{v}$, to be determined empirically. This conclusion was verified by a comparison with the experiments of M. Regnault. (*Memoirs of the Academy of Sciences*, 1847; *Trans. Roy. Soc. Edin.*, 1850; *Phil. Mag.*, Dec., 1851; *Proc. Roy. Soc. Edin.*, 1855; *Phil. Mag.*, March, 1858.)

The formula for CARBONIC ACID GAS is as follows:—

$$\frac{p v}{p_0 v_0} = \frac{\tau}{493.2} - \frac{3.42}{\tau} \cdot \frac{v_0}{v}; \dots \dots \dots (3)$$

in which $p_0 = 2116.4$ lbs. on the square foot; $v_0 = 8.15725$ cubic feet to the lb.; $p_0 v_0 = 17264$ foot-pounds.

It is probable that a formula of this class will at some future period be found to express the relation between the temperature, pressure, and density of steam; but at present it is impossible to find such a formula, for want of experimental data. The difficulty of ascertaining exactly how much of the water or other fluid within a given space is in the liquid state, and how much in the state of vapour, constitutes a serious obstacle in the way of obtaining such data. The principal causes of that difficulty are, first, that a vapour near the point of liquefaction has the power of retaining suspended in it a portion of its liquid in the state of *cloud* or *mist*; and, secondly, that if in experiments on the density and expansion of steam, glass vessels are used, in order to show when the steam is free from cloud, a new cause of uncertainty is introduced by the fact, that the attraction between glass and water is sufficient to retain in the liquid state, and in contact with the glass, a film of water at a temperature at which, but for the attraction of the glass, it would be in the state of steam.

The ideal density of perfectly gaseous steam, given in Table II., is deduced from its chemical composition. One cubic foot of hydrogen, and half a cubic foot of oxygen, combine together, and collapse into one cubic foot of steam. Hence the *ideal* weight of a cubic foot of steam at 32°, and under one atmosphere (being a quantity to be used in calculation only, inasmuch as steam cannot exist at that pressure and temperature), is computed as follows:—

	Lbs.
One cubic foot of hydrogen,	0·005592
Half a cubic foot of oxygen,	0·044628
	0·050220
One cubic foot of ideal steam, D_0 ,	= 0·050220

From this result are calculated the following, ideal also:—

$$\left. \begin{aligned}
 &\text{Volume of one lb. steam at } 32^\circ \text{ and one atmosphere;} \\
 &v_0 = \frac{1}{D_0} = 19\cdot913 \text{ cubic feet;} \\
 &p_0 v_0 = 19\cdot913 \times 2116\cdot4 = 42141 \text{ foot-lbs.}
 \end{aligned} \right\} \dots\dots(4.)$$

If from these quantities are computed the corresponding quantities for one atmosphere of pressure and 212°, the following results are obtained:—

$$\left. \begin{aligned}
 &v_1 = 1\cdot365 v_0 = 27\cdot18 \text{ cubic feet;} \\
 &D_1 = 0\cdot03679 \text{ lbs.;} \\
 &p_1 v_1 = 1\cdot365 p_0 v_0 = 57522 \text{ foot-lbs.}
 \end{aligned} \right\} \dots\dots\dots(5.)$$

The volumes and densities of steam given in Tables IV. and VI. are computed by a method which will afterwards be explained. From 32° to 104° they agree very well with the assumption of the perfectly gaseous condition, with the following values of v_0 and $p_0 v_0$, which are somewhat smaller than those deduced from chemical composition :—

$$\left. \begin{aligned} v_0 \text{ (ideal, for } 32^\circ \text{ and one atmosphere) } & 19\cdot699 \text{ cubic feet ;} \\ D_0 & 0\cdot05076 \text{ lbs. ;} \\ p_0 v_0 & 41690 \text{ foot-lbs.} \end{aligned} \right\} (6.)$$

If atmospheric steam were perfectly gaseous at 212°, the following would be the results of the above formulæ :—

$$\left. \begin{aligned} v_1 &= 1\cdot365 v_0 = 26\cdot89 \text{ cubic feet ;} \\ D_1 &= 0\cdot03719 \text{ lbs. ;} \\ p_1 v_1 &= 1\cdot365 p_0 v_0 = 56907 \text{ foot-lbs.} \end{aligned} \right\} \dots\dots\dots(7.)$$

It is proved, however, by such experimental data as exist, that the actual density of steam, at pressures of one atmosphere and upwards, exceeds that computed on the assumption of the perfectly gaseous condition, and that the excess is greater, the greater the pressure; although there is no direct experimental determination of the exact amount or law of that excess. By the indirect method to be afterwards explained, the amount of that excess is found at any given temperature; but the general law which it follows is unknown.

The tables give, for one atmosphere and 212°,

$$\left. \begin{aligned} v_1 &= 26\cdot36 \text{ cubic feet per lb. ;} \\ D_1 &= 0\cdot03797 ; \\ p_1 v_1 &= 55783 \text{ foot-lbs. ;} \end{aligned} \right\} \dots\dots\dots(8.)$$

differing by about *one-fiftieth* part from the results given in the formula (7); and the proportional difference at higher pressures is greater.

The data from which the densities and volumes in these tables were calculated, were the experiments of M. Regnault on the heat transferred from a boiler to a condenser, by sending from the former to the latter known weights of steam under different pressures; and it is certain, that whatsoever may prove to be the law connecting the density, pressure, and temperature of steam under other circumstances, the densities and volumes in these tables cannot err, to an extent appreciable in practice for steam obtained *under*

circumstances similar to those of *M. Regnault's experiments*, which circumstances are, in all important points, similar to those under which steam is obtained in ordinary steam engines.

In the *Proceedings* of the Institution of Mechanical Engineers for June, 1852, was published a paper by Mr. C. W. Siemens containing the results of experiments "on the expansion of isolated steam." Those experiments show a very rapid rate of expansion with increase of temperature under constant pressure near the boiling point corresponding to the pressure, and a gradually diminishing rate as the temperature rises. For steam under the pressure of one atmosphere, and at temperatures varying from 250° to 380° Fahrenheit, Mr. Siemens's experiments give as the mean co-efficient of expansion,

$$\frac{dv}{v_0 dt} = 0.00385 \text{ nearly;}$$

the co-efficient of expansion of a perfect gas being 0.0020276.

The experiments which have for some time been in progress by *M. Regnault*, and those lately undertaken by *Mr. Fairbairn* and *Mr. Unwin*, may be expected to give precise data on the subject of the density of steam, and its expansion by heat.

In Table V., the densities of the vapour of æther are computed as for a perfect gas from its chemical composition; because in the only case in which data exist for computing its density otherwise, the results of the two modes of computation agree exactly, as will afterwards be shown.

The quantities in the column headed E in Table II., being the expansions of unity of volume at 32° in rising to 212°, are 180 times the *co-efficients of expansion per degree* of Fahrenheit.

203. Expansion of Liquids—Mercurial Thermometer.—The rate of expansion of every liquid increases as the temperature becomes higher, and diminishes as the temperature becomes lower.

In the case of water, there is a temperature at which the rate of expansion disappears, and the volume of a given weight reaches a minimum. That temperature, according to the most trustworthy experiments, is

$$39^{\circ}.1 \text{ Fahrenheit} \dots \dots \dots (1.)$$

Between that temperature and 32°, the volume of a given weight of water *increases by cold*.

It is possible that a similar phenomenon may take place in other liquids; but it has not yet been observed in any liquid except water.

The above temperature of the maximum density of water, being the temperature at which the specific gravity of water can be most accurately ascertained, is used in France as the standard tempera-

ture, at which the weight of an unit of volume of water is taken for an unit of weight, and of specific gravity. The standard temperature for the British standards of weight and measure is 62° Fahrenheit.

The following empirical formula for the expansion of water between 32° and 77° Fahrenheit, deduced from the experiments of Stampfer, Despretz, and Kopp, is extracted from Professor W. H. Miller's paper on the Standard Pound, in the *Philosophical Transactions* for 1856, and reduced so as to be suited to Fahrenheit's scale instead of the Centigrade scale, for which it was originally computed :—

$$\log \frac{v}{v_0} = \frac{10.1 (T - 39.1)^2 - 0.0369 (T - 39.1)^3}{10,000,000} \dots(2.)$$

v_0 denotes the volume of a given weight of water at 39°·1 Fahrenheit, and under one atmosphere of pressure, which for one pound of water, has the value

$$v_0 = \frac{1}{62.425} = 0.0160192; \dots\dots\dots(3.)$$

$\log v_0 = \bar{2}.2046414.$

v denotes the volume of the same weight of water at any other temperature T on Fahrenheit's scale.

For rough calculations of the density of water, a simple approximate formula, suited for most practical purposes, has already been given in Article 107, p. 110.

The greater convenience of thermometers filled with liquid, as compared with those filled with air, causes the former to be employed for all purposes except certain special scientific researches; and the liquid commonly employed is mercury.

A mercurial thermometer consists of a bulb and stem of glass. The stem should be as nearly as possible of uniform bore; and the inequalities in the bore should be ascertained by passing a small quantity of mercury along the stem, and marking the lengths that it occupies in different positions; and in the graduation of the scale those inequalities should be allowed for, so that each degree of the scale shall correspond to an equal portion of the capacity of the stem. A sufficient quantity of mercury having been introduced, it is boiled, to expel air and moisture, and the tube is hermetically sealed. The standard points are ascertained by immersing the thermometer in melting ice, and in the steam of water boiling under the pressure of 14.7 lbs. on the square inch, and marking the positions of the top of the column; the interval between those points is divided into the proper number of degrees (100 for the Centigrade scale, 180 for Fahrenheit's scale), and similar degrees

are marked above and below those points if necessary, the ascertained inequalities in the bore of the stem being allowed for.

The rate of expansion of mercury with rise of temperature increases as the temperature becomes higher; from which it follows, that if a thermometer showing the dilatation of mercury simply were made to agree with an air thermometer at 32° and 212° , the mercurial thermometer would show lower temperatures than the air thermometer between those standard points, and higher temperatures beyond them. For example, according to M. Regnault (*Mem. Acad. Sc.*, 1847), when the air thermometer marked 350° C. ($= 662^{\circ}$ F.), the mercurial thermometer would mark $362^{\circ}\cdot 16$ C. ($= 683^{\circ}\cdot 89$ F.), the error of the latter being in excess, $12^{\circ}\cdot 16$ C. ($= 21^{\circ}\cdot 89$ F.)

Actual mercurial thermometers indicate intervals of temperature proportional to the apparent expansion of mercury contained in a glass vessel,—that is, the difference between the expansion of mercury and that of glass.

The inequalities in the rate of expansion of the glass (which are very different for different kinds of glass) correct, to a greater or less extent, the errors arising from the inequalities in the rate of expansion of the mercury.

For practical purposes connected with heat engines, the mercurial thermometer made of common glass may be considered as sensibly coinciding with the air thermometer at all temperatures not exceeding 500° Fahr.

For full information on the comparative indications of thermometers, reference may be made to M. Regnault's papers in the *Memoirs of the Academy of Sciences* for 1847, entitled respectively "De la Mesure des Temperatures," and "De la Dilatation Absolue du Mercure."

Spirit thermometers are used to measure temperatures at and below the freezing point of mercury. Their deviations from the air thermometer are greater than those of the mercurial thermometer.

204. Expansion of Solids.—The numbers which it is customary to give in tables of the expansion of solids are the *rates of expansion of one dimension*, and are therefore respectively *one-third* of the corresponding rates of expansion in volume.

Solid thermometers are sometimes used, which indicate temperatures by showing the difference between the expansions of a pair of bars of two substances whose rates of expansion are different. When such thermometers are used to indicate temperatures higher than the boiling point of mercury under one atmosphere (about 676° Fahr.), they are called *Pyrometers*. In this case the exact value of their degrees is somewhat uncertain.

205. **Melting Point.**—One melting point has already been mentioned as a fixed temperature,—that of ice. It is *lowered* by pressure to the extent of $0\cdot014$ for each additional atmosphere of pressure,—a fact predicted by Prof. James Thomson, and ascertained experimentally by Prof. William Thomson.

The following are the melting points of a few of the more important substances. Those marked ? have been measured by the pyrometer :—

Mercury,.....	— 38°	Bismuth,.....	493°
Ice,.....	+ 32°	Lead,.....	630°
Alloy—Tin 3, Lead 5,		Zinc,.....	700° ?
Bismuth 8, about,.....	210°	Silver,.....	1280° ?
Sulphur,.....	228°	Brass,.....	1869° ?
Alloy—Tin 4, Bismuth 5,		Copper,.....	2548° ?
Lead 1,.....	246°	Gold,.....	2590° ?
Alloy—Tin 1, Bismuth 1,	286°	Cast iron,.....	3479° ?
Alloy—Tin 3, Lead 2,...	334°	Wrought iron, higher, but	
Alloy—Tin 2, Bismuth 1,	334°	uncertain.	
Tin,.....	426°		

Ice, cast iron, bismuth, and antimony, and, according to Mr. Nasmyth, many other substances, are more bulky when in the solid state, near the melting point, than they are when in the liquid state; as is shown by the solid material floating in the melted material.

For ice, the excess of volume in the solid state above the volume in the liquid state is very great, and has been ascertained, with the following results :—

	Volume of 1 lb. cubic feet.	Weight of 1 cub. ft. in lbs.
Water, at 32°.....	0·01602	62·425
Ice, at 32°.....	0·0174	57·5

206. **Pressure of Vapour—Evaporation—Boiling.**—The temperature at which a given fluid boils under a given pressure, is a fixed temperature. In order to explain this phenomenon, and the laws which it follows, it is necessary in the first place to describe the distinctions between the liquid and gaseous conditions, and the mode in which substances pass from the one to the other.

I. The *Liquid* state is that condition of each internal part of a body, which consists in tending to preserve a definite volume, and resisting change of volume, and in offering no resistance to change of figure. It is known that most substances, and believed that all substances, are capable of assuming the liquid condition under suitable circumstances. The property of offering no resistance to

change of figure, is common to the condition of *liquid* and *gas*, and constitutes the *fluid* condition. The liquid condition is distinguished from the gaseous by the property of tending to preserve a definite volume: a body in the gaseous condition tends to expand indefinitely. Rise of temperature increases the resistance of liquids to compression, and diminishes their cohesion. It is known of most liquids, and believed of all, that for each temperature of a given substance, there is a certain minimum pressure on its external surface, which is necessary to its existence in the liquid state, and under which the communication of additional heat to the liquid mass, makes it boil, or emit bubbles of vapour from its interior. There is also reason to believe, that all liquids under all circumstances emit vapour from their surfaces, and are surrounded by an atmosphere of their own vapour.

II. *Vapour* is any substance in the gaseous condition, at the maximum of density consistent with that condition. This is the strict and proper meaning of the word "Vapour." It is sometimes used in an extended sense, identical with that of "gas," in speaking of substances whose ordinary condition is the liquid or solid. It is certain that most substances are *volatile*, that is to say, that they can and do exist in the state of vapour, at all attainable temperatures. Many vapours, whose existence cannot be proved by mechanical or chemical processes, are obvious to the sense of smell; for example, those of iron, copper, lead, and tin. Whether *all* substances are volatile at all temperatures is yet uncertain. If there be cases of exception, it is to be understood that the laws stated in the sequel of this Article do not apply to them.

III. *Pressure and Density of Vapours*.—For each volatile substance at each temperature, there is a certain pressure which is at once the least pressure under which the substance can exist in the liquid or solid state, and the greatest pressure which it can sustain in the gaseous state at the given temperature. That pressure is called the *pressure of saturation*, or the *pressure of vapour* of the given substance at the given temperature; it is a function of the temperature; and the density of the vapour is a function of the pressure and the temperature. The relation between the pressure of vapour and the temperature, for various substances, has been the subject of many series of experiments, of which the latest and best are those of M. Regnault on steam (*Memoirs de l'Academie des Sciences*, 1847), and on various other vapours (*Comptes Rendus*, 1854). The best sources of information as to the pressures of vapours are the tables computed by M. Regnault from those experiments; but such pressures may also be computed in most cases with great accuracy by the aid of a formula, which, with the constants applicable to vapours, as deduced from M. Regnault's experiments,

was first given in the *Edinburgh Philosophical Journal* for July, 1849, and afterwards, with revised constants, in the *Philosophical Magazine*, Dec., 1854. The following is the formula for calculating the pressure p of vapour from the absolute temperature $\tau = T + 461\cdot2$ Fahr. of the boiling point :—

$$\log p = A - \frac{B}{\tau} - \frac{C}{\tau^2} \dots\dots\dots(1.)$$

The following is the inverse formula for calculating the absolute temperature of the boiling point from the pressure :—

$$\tau = 1 \div \left\{ \sqrt{\left(\frac{A - \log p}{C} + \frac{B^2}{4C^2} \right) - \frac{B}{2C}} \right\} \dots\dots(2.)$$

The following are the values of the constants in the formula, for temperatures in degrees of Fahrenheit, and pressures in *pounds on the square foot* :—

FLUID.	A.	log B.	log c.	$\frac{B}{2C}$	$\frac{B^2}{4C^2}$
Water,.....	8·2591 ...	3·43642...	5·59873...	0·003441...	0·00001184
Alcohol, ...	7·9707 ...	3·31233...	5·75323...	0·001812...	0·000003282
Æther,.....	7·5732 ...	3·31492...	5·21706...	0·006264...	0·00003924
Bisulp. of } Carb.,.. }	7·3438 ...	3·30728...	5·21839...	0·006136...	0·00003765
Mercury,...	7·9691 ...	3·72284			

For inches of mercury at 32°, subtract from A,.....1·8496
 „ lb. on the square inch, „ A,.....2·1584
 For the Centigrade scale, subtract from log B,.....0·25527
 „ log C,.....0·51054
 multiply $\frac{B}{2C}$ by 1·8
 „ $\frac{B^2}{4C^2}$ by 3·24

From the preceding formula and constants were calculated the pressures in Tables IV. and VI. for steam, and Table V. for æther, at the end of this volume.

The general result of such formulæ and tables is, that the pressure of vapour increases with the temperature at a rate which itself increases rapidly with the temperature. If any vapour were a perfect gas, its *density* D_2 , at any temperature T_2 , might easily be computed, when its density D_1 , at some other temperature T_1 , had been ascertained by experiment, by means of the formula,

$$\frac{D_2 (T_2 + 461 \cdot 2 \text{ Fahr.})}{p_2} = \frac{D_1 (T_1 + 461 \cdot 2 \text{ Fahr.})}{p_1}; \dots (1 A.)$$

in which p_1 and p_2 are the pressures of the vapour at the temperatures T_1 and T_2 respectively; but no vapour is an absolutely perfect gas; and the density of every vapour increases more rapidly with increase of pressure than that which would be given by the above formula. That formula, however, is sufficiently near the truth for practical purposes when the density of the vapour is below certain limits, as is the case with the vapours of most substances at the temperatures which usually occur in the atmosphere. The experimental determination of the densities of vapours, to a certain rough degree of approximation, sufficient to enable the formula (1 A) to be applied, is easy, and is assisted by a knowledge of their chemical composition, in consequence of the well established laws, *first*, that perfect gases combine by volumes in simple numerical ratios only; and, *secondly*, that the volume of a given weight of a compound perfect gas always bears simple numerical ratios to the volumes which its constituents would occupy separately. Examples of the application of these laws are given in the case of steam, in Art. 202, equations 4, 5, and in some parts of Table II., marked thus, *. The direct experimental determination of the densities of vapours, to a degree of accuracy sufficient to show the *exact* amount of their deviation from the perfectly gaseous condition, has not yet been accomplished. A method of computing the probable value of such densities theoretically, from the heat which disappears in evaporating a given quantity of the substance, will be explained in Chapter III.

IV. *Atmospheres of Vapour—Spheroidal State.*—From what has been stated, it appears that every solid or liquid substance in a state of molecular equilibrium, wherever it is not enveloped by another solid or liquid substance, is enveloped by an atmosphere of its own vapour, of a density and pressure depending on the temperature (provided the substance is volatile at that temperature). It has been suggested as a hypothesis, that the density of a very thin layer of this atmosphere, immediately adjoining the surface of such liquid or solid, may, owing to the attraction of the liquid or solid, be much greater than the density at considerable distances, and that the elasticity of an atmosphere of vapour so constituted may be the cause of that resistance to being brought into absolute contact, which is displayed by the surfaces of solid and liquid bodies in general (*e. g.*, when raindrops roll on the surface of a river), and which is so great at high temperatures as to produce what is called the "*spheroidal state*" of masses of liquid, in which they remain suspended over hot solid surfaces with a visible interval between. The only substance on the earth's surface which is sufficiently

abundant to pervade the whole of the earth's atmosphere at all times with vapour to an amount appreciable by mechanical and chemical processes, is water.

V. *Mixtures of Vapours and Gases.*—It has already been explained, in Article 199, that the pressure exerted against the interior of a vessel by a given quantity of a perfect gas enclosed in it, is the sum of the pressures which any number of parts into which such quantity might be divided would exert separately, if each were enclosed in a vessel of the same bulk alone, at the same temperature; and that, although this law is not exactly true for any actual gas, it is very nearly true for many. Thus, if 0·080728 lb. of air, at 32°, being enclosed in a vessel of one cubic foot of capacity, exerts a pressure of one atmosphere, or 14·7 lbs., on each square inch of the interior of the vessel, then will each additional 0·080728 lb. of air which is enclosed, at 32°, in the same vessel, produce very nearly an additional atmosphere of pressure. It has now further to be explained, that *the same law is applicable to mixtures of gases of different kinds.* For example, 0·12344 lb. of carbonic acid gas, at 32°, being enclosed in a vessel of one cubic foot in capacity, exerts a pressure of one atmosphere; consequently, if 0·080728 lb. of air and 0·12344 lb. of carbonic acid, mixed, be enclosed at the temperature of 32° in a vessel of one cubic foot of capacity, the mixture will exert a pressure of two atmospheres. As a second example: let 0·080728 lb. of air, at 212°, be enclosed in a vessel of one cubic foot, it will exert a pressure of

$$\frac{212^{\circ} + 461^{\circ}\cdot2}{32^{\circ} + 461^{\circ}\cdot2} = 1\cdot365 \text{ atmosphere.}$$

Let 0·03797 lb. of steam, at 212°, be enclosed in a vessel of one cubic foot: it will exert a pressure of one atmosphere. Consequently, if 0·080728 lb. of air and 0·03797 lb. of steam be mixed and enclosed together, at 212°, in a vessel of one cubic foot, the mixture will exert a pressure of 2·365 atmospheres. It is a common but erroneous practice, in elementary books on physics, to describe this law as constituting a *difference* between mixed and homogeneous gases; whereas it is obvious, that for mixed and homogeneous gases the law of pressure is exactly the same,—viz., that *the pressure of the whole of a gaseous mass is the sum of the pressures of all its parts.* This is one of the laws of mixtures of gases and vapours. A second law is, that *the presence of a foreign gaseous substance in contact with the surface of a solid or liquid, does not affect the density of the vapour of that solid or liquid,* unless (as M. Regnault has recently shown) there is a tendency to chemical combination between the two substances, in which case the density of the vapour

is slightly increased. For example: let there be a mass of liquid water in a receiver, at the temperature of 212° , and above the surface of the liquid water let there be a space of one cubic foot; it is necessary to molecular equilibrium at the given temperature of 212° , that that space of one cubic foot should contain 0.03797 lb. of steam, whether the space be void of all other substances, or filled with any quantity of air, or of any other gaseous substance which does not exert an appreciable chemical attraction on the water. To illustrate the law further, let the temperature of the water be 50° ; then it is necessary to molecular equilibrium that the space of one cubic foot above the water should contain 0.00058 lb. of watery vapour, whether and to what amount soever air, or any other gaseous substance not chemically attracting the water, is contained in the same space. This and the preceding law of mixtures of gases and vapours (discovered by Dalton and Gay-Lussac), enable the following question to be solved:—*Problem.* Given the total pressure P , of a mixture of a gas and of a given vapour, in a space saturated with the vapour at the temperature T ; required the pressure and density of the gas separately.—*Solution.* Find, from a table of experiments, or from a formula, the pressure of saturation of the vapour for the given temperature T ; let it be denoted by p ; then the pressure of the gas is $P - p$; and its density is less than the density which it would have had under the pressure P , if no vapour had been present, in the ratio

$$\frac{P - p}{P}.$$

Example. A space contains mixed air and steam, being saturated with steam at 50° , and the total pressure is 14.7 lbs. on the square inch; what is the pressure of the air separately, and what weight of air is contained in each cubic foot of the space?—*Answer.* Either from M. Regnault's experiments, or from the formula already cited, it appears that the pressure of the steam is 0.173 lb. per square inch; consequently, the pressure of the air separately is $14.7 - 0.173 = 14.527$ lbs. per square inch. Also, the weight of air in a cubic foot, at 14.7 lbs. per square inch and 50° , had there been no steam present, would have been

$$0.080728 \times \frac{493.0.2}{50^{\circ} + 461^{\circ}.2} = 0.077885 \text{ lb.};$$

consequently the weight of air actually present along with the steam, in a cubic foot, is

$$0.077885 \times \frac{14.527}{14.7} = 0.07698 \text{ lb.}$$

A second problem is, to find the density of the mixture of gas and vapour; which is solved by adding to the density of the gas already found, the density of the vapour as computed by the methods formerly referred to. Thus, in the case last given, it appears, by computing from the latent heat of evaporation, that the weight of steam in a cubic foot is 0.00058 lb.; consequently, the weight of a cubic foot of the mixture of air and steam is $0.07698 + 0.00058 = 0.07756$ lb. With respect to the amount of the deviations from the foregoing laws, which occur when the ingredients of the gaseous mixture have a chemical affinity for each other, the reader is referred to the later researches of M. Regnault already mentioned, *Comptes Rendus*, 1854.

VI. *Evaporation and Condensation.*—When the density of the vaporous atmosphere of a solid or liquid is diminished, either by the enlargement of the space in which the substance is contained, or by the removal of part of the vapour, whether by mechanical displacement (as when it is blown away by a current of air) or by condensation in an adjoining space, the solid or liquid evaporates until equilibrium is restored, by the restoration of the vapour to the density corresponding to the existing temperature. The same thing takes place when the molecular equilibrium is disturbed by communicating heat to the solid or liquid. When the density of the vaporous atmosphere is increased, either by the contraction of the space in which the substance is contained, or by the addition of vapour from another source, part of the vapour condenses until equilibrium is restored as before. The same thing takes place when the molecular equilibrium is disturbed by abstracting heat from the vapour. Evaporation is accompanied by the disappearance of heat, called the *Latent Heat of Evaporation*, and condensation by the re-appearance of heat, according to laws to be stated in Section 2 of this Chapter. When the space above the solid or liquid is void of foreign substances, the restoration of equilibrium is sensibly instantaneous; when that space contains foreign gaseous substances, the restoration of equilibrium is more or less *retarded*, although the conditions of equilibrium (as stated in Division V. of this Article) are not changed. It is the retardation of the diffusion of watery vapour by the presence of air which prevents every part of the earth's atmosphere from being always saturated with moisture.

VII. *Ebullition.*—When the communication of heat to a liquid mass and the removal of the vapour are carried on continuously, so that the pressure throughout the mass of liquid is not greater than that of saturation for its temperature, evaporation takes place, not merely from the exposed surface of the liquid, but also from its interior: it gives out bubbles of vapour, and is said to *boil*. The ascertaining by experiment of the temperatures of ebullition, or

boiling points, of a liquid under various pressures, is the most accurate method of determining the relation between the temperature and pressure of saturation of its vapour. Conversely, when that relation is known for a given fluid, and expressed by formulæ or tables, the boiling point of the fluid may be made the means of measuring the pressure on it. On this principle is founded the method invented by Wollaston, and since perfected by Dr. J. D. Forbes, of deducing the atmospheric pressure, and thence the elevation of the place of observation, from the boiling point of water in an open vessel, as measured by a very delicate thermometer. (See *Edinburgh Transactions*, vols. xv. and xxi.)—When the term *boiling point* of a fluid is used without qualification, it means the boiling point under the average atmospheric pressure of 14·7 lbs. on the square inch.

VIII. *Resistance to Boiling—Brine*.—The presence in a liquid of a substance dissolved in it (as salt in water), resists ebullition, and raises the temperature at which the *liquid boils*, under a given pressure; but unless the dissolved substance enters into the composition of the *vapour*, the relation between the temperature and pressure of saturation of the latter remains unchanged. A resistance to ebullition is also offered by a vessel of a material which attracts the liquid (as when water boils in a glass vessel), and the boiling takes place by starts. To avoid the errors which causes of this kind produce in the measurement of boiling points, it is advisable to place the thermometer not in the liquid, but in the vapour, which shows the true boiling point, freed from the disturbing effect of the attractive nature of the vessel. The boiling point of saturated brine under one atmosphere is 226° Fahr., and that of weaker brine is higher than the boiling point of pure water by 1°·2 Fahr. for each $\frac{1}{4}$ of salt that the water contains. Average sea water contains $\frac{1}{4}$; and the brine in marine boilers is not suffered to contain more than from $\frac{1}{4}$ to $\frac{3}{4}$.

IX. *Nebulous or Vesicular Vapour* is a condition of fluids, also called *Cloud*, *Mist*, or *Fog*, in which the liquid floats in the air, or in its own vapour, in the form of innumerable small globules. The condition of cloud is one into which fluids pass from the state of vapour on being condensed by mingling with cold air. By heat, the globules of cloud are made to evaporate and disappear; by cold they are made to coalesce into drops, which fall to the ground, or adhere to neighbouring solid bodies.

X. *Superheated Vapour* means vapour which has been brought to a temperature higher than the boiling point corresponding to its pressure, so as to be in the condition of a permanent gas.

SECTION 2.—*Of Quantities of Heat.*

207. **Comparison of Quantities of Heat.**—The condition of heat is measured as a quantity, and its amounts in different bodies and under different circumstances compared, by means of the changes in some measurable phenomenon produced by its transfer or disappearance. Amongst the changes used for this purpose, changes of *temperature* will be first considered. Heat employed in producing elevation of temperature is called *sensible heat*.

In so using changes of temperature, it is not to be taken for granted that equal differences of temperature in the same body correspond to equal quantities of heat. This is the case, indeed, for perfectly gaseous bodies; but that is a fact only known by experiment. In bodies in other conditions, equal differences of temperature do not exactly correspond to equal quantities of heat. To ascertain, therefore, by an experiment on the changes of temperature of any given substance, what proportion two quantities of heat bear to each other, the only method which is of itself sufficient in the absence of all other experimental data, is the comparison of the *weights* of that substance which are raised from one and the same lower temperature, to one and the same higher fixed temperature, by the transfer to them of the two quantities of heat respectively. For example, the double of the quantity of heat which raises the temperature of *one pound* of water from 32° to $32^\circ + 30^\circ = 62^\circ$, is *not* exactly the quantity of heat which raises the temperature of one pound of water from 32° to $32^\circ + 60^\circ = 92^\circ$; but it is exactly the quantity of heat which raises the temperature of *two pounds* of water from 32° to 62° .

The most usual experiments on quantities of heat are those in which the *equality* of two quantities of heat is ascertained. For example, m pounds of a substance A, at a temperature T_1 , and n pounds of a substance B at a lower temperature T_3 , are brought into close contact, and either they are guarded against the transfer of heat to or from third bodies, or if such transfer is unavoidable, its amount is ascertained and allowed for. After a sufficient time has elapsed, equilibrium of temperature takes place, by both bodies acquiring the same temperature T_2 , intermediate between T_1 and T_3 .

Then a certain amount of the condition called *heat* has been transferred from A to B; and the effects of that transfer are—

- I. The lowering of the temperature of m pounds of A from T_1 to T_2 ;
 - II. The raising of the temperature of n pounds of B from T_3 to T_2 ;
- from which we conclude, that the quantities of heat corresponding to those two effects are equal.

A further inference from the same experiment is the following proportion:—

Quantity of heat corresponding to the interval of temperature between T_1 and T_2 in the substance A,
 : Quantity of heat corresponding to the interval of temperature between T_2 and T_3 in the substance B

:: n : m .

The same mode of experimenting may be applied to two portions of the same substance, so as to compare the quantities of heat corresponding to intervals of temperature in different parts of the thermometric scale.

207 A. **A Calorimeter**, or instrument for measuring quantities of heat, consists essentially of a vessel containing a known weight of some convenient liquid, such as water or mercury—a thermometer for indicating the temperature of that liquid,—and if necessary, an agitator, or fan, for making the liquid circulate, in order that all its parts may be at an uniform temperature at the same instant.

Experiments of the kind mentioned in Article 207 are performed by immersing in the liquid, or mixing with it, a known weight of the substance to be experimented on, at a known temperature, different from the temperature of the liquid, and noting the common temperature of the liquid and of the immersed substance when equilibrium of temperature is restored; taking care at the same time that all losses of heat, and other causes of error, are ascertained and allowed for.

In the mercurial calorimeter of MM. Favre and Silbermann, there is no independent thermometer; the instrument being simply a mercurial thermometer with a bulb so large, that the body to be experimented upon can be enclosed in a small chamber in the centre of the bulb, so as to insure that all the heat which that body loses shall be transferred to the mercury. This calorimeter has no agitator.

For examples of the construction and use of the water calorimeter, see M. Regnault's papers in the *Memoirs of the Academy of Sciences* for 1847.

208. **Unit of Heat**.—For the purpose of expressing and comparing quantities of heat, it is convenient to adopt as an UNIT OF HEAT or THERMAL UNIT, that quantity of heat which corresponds to some definite interval of temperature in a definite weight of a particular substance.

The thermal unit employed in Britain is—

The quantity of heat which corresponds to an interval of one degree of Fahrenheit's scale in the temperature of one pound of pure liquid water, at and near its temperature of greatest density (39°·1 Fahrenheit).

The reason for the limitation to that part of the scale of tem-

perature which is near the temperature of the greatest density of water is, that the quantity of heat corresponding to an interval of one degree in a given weight of water is not exactly the same in different parts of the scale of temperatures, but increases as the temperature rises, according to a law which will be stated in the next Article.

For temperatures not higher than 80° Fahrenheit, that quantity is sensibly constant.

The thermal unit employed in France (called *Calorie*) is the quantity of heat which corresponds to an interval of one *Centigrade degree* in the temperature of one *kilogramme* of pure liquid water, at and near its temperature of greatest density.

The following statement shows the mutual ratios of the British and French units of weight, temperature, and heat, with the logarithms of those ratios:—

	Ratios.	Logarithms.
Pounds avoirdupois in a kilogramme,.....	2·20462	0·3433340
Kilogramme in a lb. avoirdupois,.....	0·453593	1·6566660
Fahrenheit degrees in a Centigrade degree, 1·8		0·2552725
Centigrade degree in a Fahrenheit degree,...	0·555	1·7447275
British thermal units in a French thermal unit,.....	} 3·96832	0·5986065
French thermal unit in a British thermal unit,.....		
	0·251996	1·4013935

Other units in which quantities of heat can be expressed will be afterwards explained.

209. **Specific Heat of Liquids and Solids.**—The *specific heat* of a substance means the quantity of heat, expressed in thermal units, which must be transferred to or from an unit of weight (such as a pound) of a given substance, in order to raise or lower its temperature by one degree.

According to the definition of a thermal unit given in Article 208, the specific heat of liquid water at and near its temperature of maximum density is *unity*; and the specific heat of any other substance, or of water itself at another part of the scale of temperatures, is the *ratio of the weight of water at or near 39°·1 Fahrenheit, which has its temperature altered one degree by the transfer of a given quantity of heat, to the weight of the other substance under consideration, which has its temperature altered one degree by the transfer of an equal quantity of heat*: the equality of quantities of heat being ascertained in the manner explained in Article 207.

The specific heat of a substance is sometimes called its "*capacity for heat.*"

The specific heats of the substances to which reference will afterwards have to be made in this treatise, as expressed in ordinary thermal units, are given in the columns headed C in Table II., at the end of the volume.

So far as those tables relate to liquids and solids, those quantities are to be regarded as merely approximate average values, near enough to the truth for practical purposes at the temperatures which usually occur; for the specific heat of every substance in the liquid or solid state is variable, becoming greater as the temperature rises; and that to an extent which is in general greater, the more expansible the substance is.

The only substance for which the exact law of that variation has been ascertained is water, on whose specific heat a series of precise experiments was made by M. Regnault, and published in the *Memoirs of the Academy of Sciences* for 1847.

The following empirical formulæ, first published in the *Transactions of the Royal Society of Edinburgh* for 1851, represent very closely the results of those experiments.

Let T be the temperature of the water, reckoned from the ordinary zero of Fahrenheit's scale. Then the specific heat of water at that temperature is

$$c = 1 + 0.000000309 (T - 39^\circ.1)^2; \dots\dots\dots(1.)$$

the number of units of heat required to raise one pound of water from any temperature T_1 to any other temperature T_2 is as follows:—

$$h = \int_{T_1}^{T_2} c dT = T_2 - T_1 + 0.000000103 \{ (T_2 - 39^\circ.1)^3 - (T_1 - 39^\circ.1)^3 \} \dots\dots\dots(2.)$$

and the *mean specific heat* between any given pair of temperatures, T_1 and T_2 , is

$$\frac{h}{T_2 - T_1} = 1 + 0.000000103 \{ (T_2 - 39^\circ.1)^2 + (T_2 - 39^\circ.1)(T_1 - 39^\circ.1) + (T_1 - 39^\circ.1)^2 \} \dots\dots\dots(3.)$$

To adapt these formulæ to the Centigrade scale, the following alterations are to be made:—

for 0.000000309	is to be put	0.000001;
for 0.000000103	„	0.00000033;
for $T - 39^\circ.1$,	„	$T - 4^\circ$.

The exact equivalent of $39^\circ.1$ Fahrenheit is $3^\circ.94$ Centigrade; but 4° is sufficiently near the truth for the present purpose.

In calculations respecting the quantities of heat required by masses composed of various materials to produce given alterations of temperature, it is convenient to substitute for the weight of each material an equivalent weight of water, and then to calculate for the whole mass as if it were composed of water. The equivalent weight of water is found in each case by multiplying the weight of the material in question by its specific heat.

Suppose, for example, that a calorimeter contains m pounds of water, and that the vessel and the agitator are made of copper, and weigh q pounds. The solid part of the apparatus accompanies the water in its changes of temperature; and the heat required to produce these changes must be taken into account. This is conveniently done by supposing that for the q pounds of copper there are substituted $\cdot 0951 q$ pounds of water ($\cdot 0951$ being the specific heat of copper); and then computing the results of experiments made with the calorimeter as if it consisted solely of

$$m + \cdot 0951 q \text{ pounds of water.}$$

The following are the specific heats of a few liquids and solids, in addition to those given in Table II. at the end of the volume. Some are given on the authority of M. Regnault; some on that of Lavoisier and Laplace, some on that of Dalton, and the specific heat of ice on that of M. Person.

Ice,.....	0.504
Sulphur,.....	0.20259
Charcoal,.....	0.2415
Coal and coke average,.....	0.201
Alumina (Corundum),.....	0.19762
Do. (Sapphire),.....	0.21732
Silica,.....	0.19132

(*Brick*, being composed of silica and alumina, has probably a specific heat of about 0.2).

Flint glass,.....	0.19
Carbonate of lime,.....	0.2085
Quicklime,.....	0.2169
Magnesian limestone,.....	0.21743

(*Stones*, being composed chiefly of silica, alumina, and carbonates of lime and magnesia, have probably specific heats not differing greatly from 0.2 or 0.22).

Olive oil,.....	0.3096.
-----------------	---------

From some of the above data may be deduced the useful prac-

tical conclusion, that the *average specific heat of the non-metallic materials and contents of a furnace, whether bricks, stones, or fuel, does not greatly differ from one-fifth of that of water.*

It was discovered by Dulong and Petit, and has been verified by MM. Regnault, Newmann, and Avogadro, that most known substances may be arranged according to the analogies of their chemical constitution in groups; and that in any one given group the specific heats of the substances are with few exceptions inversely as their chemical equivalents; or, in other words, that the product of the specific heat of a substance by its chemical equivalent is a constant for most of the substances in one group.

For most of the metals, for example, that constant product is,—

According to the French scale of chemical equivalents, ... 37·5;
According to the English scale, 6.

210. **Specific Heat of Gases.**—Although the exact value of the specific heat of air was predicted by an indirect calculation in 1850, neither it, nor that of any other gas, was determined accurately by direct experiment until M. Regnault made his experiments on that subject, the results of which were published in the *Comptes Rendus* of the Academy of Sciences for 1853.

The specific heat of a gas which is nearly in the perfectly gaseous state does not sensibly vary with density or with temperature; so that for such a gas, equal intervals of temperature correspond to equal quantities of heat on all parts of the thermometric scales.

Hence it has been inferred as probable, that the absolute zero of the perfect gas thermometer (Article 201) coincides either exactly, or very nearly, with the *absolute zero of heat*, or temperature at which bodies are wholly destitute of the condition called heat. This inference is corroborated by facts to be mentioned in Chapter III. of this Part.

It was shown by Laplace and Poisson, that the specific heat of a gas is different, according as it is maintained at a *constant volume*, or at a *constant pressure*, during the operation of changing its temperature, and that the ratio which these two specific heats bear to each other is connected with the velocity with which sound is transmitted through the gas, in the following manner:—

When a pound of a given gas is enclosed in a vessel of *invariable volume*, let c_v denote the number of units of heat required in order to raise its temperature one degree.

When the same weight of the same gas is contained in a space capable of enlargement, and subjected to a *constant pressure*, and when its temperature is raised by one degree, it not only *becomes hotter* to the same extent as before, but also *expands* by 0·0020276 of its volume at 32°; and it is known, that to raise its temperature

one degree, and expand its volume by that fraction, requires a quantity of heat c_p , which is greater in a certain proportion than that required merely to raise its temperature one degree without expanding it (c_v).

Let the ratio $\frac{c_p}{c_v} = \gamma$. Then it can be shown, that when the density of the gas D is made to vary without any transfer of heat to or from the gas, the pressure varies proportionally to that power of the density whose index is the ratio γ ; that is—

$$p \propto D^\gamma \dots \dots \dots (1.)$$

The velocity with which sound is transmitted through any substance is the same with that which a heavy body would acquire in falling through one-half of the height which, being multiplied by a small variation of the density of the substance, gives the corresponding small variation of the pressure. That is, let u denote the velocity of sound; then

$$u = \sqrt{\left(\frac{g \, d p}{d D}\right)} \dots \dots \dots (2.)$$

According to equation 1, for a gas,

$$\frac{d p}{d D} = \frac{\gamma p}{D} = \gamma p v = \gamma p_0 v_0 \cdot \frac{\tau}{\tau_0}; \dots \dots \dots (3.)$$

and consequently,

$$u = \sqrt{\left(g \gamma p_0 v_0 \cdot \frac{\tau}{\tau_0}\right)}; \gamma = \frac{u^2 \tau_0}{g p_0 v_0 \tau} \dots \dots \dots (4.)$$

so that when the velocity of sound at a given absolute temperature τ has been ascertained in a gas for which $p_0 v_0$ is known, the ratio γ can be calculated.

The value of that ratio for atmospheric air, as deduced from the experiments of MM. Bravais and Martins, and MM. Moll and Van Beek, on the velocity of sound, is

$$\gamma = 1.408; \dots \dots \dots (5.)$$

and the same value agrees very nearly also with the experiments of Dulong on the velocity of sound in oxygen, hydrogen, and carbonic oxide. For the denser and more complex gases, its value appears to be smaller (see *Edin. Trans.*, xx.)

Owing to the difficulty of experimenting on the specific heats of gases at constant volume, their specific heats under constant pres-

sure have alone been found by direct experiment with the calorimeter. Examples of both kinds of specific heat are given in Table II.

211. **Latent Heat** means, a quantity of heat which has *disappeared*; having been employed to produce some change other than elevation of temperature. By exactly reversing that change, the quantity of heat which had disappeared is reproduced.

When a body is said to possess or *contain* so much latent heat, what is meant is this,—that the body is in a condition into which it was brought from a former different condition by transferring to it a quantity of heat which did not raise its temperature, the change of condition having been different from change of temperature; and that by restoring the body to its original condition in such a manner as *exactly to reverse* all the steps of the former process, the quantity of heat formerly expended can be reproduced in the body and transferred to other bodies.

The principles according to which such disappearance and production of heat take place belong to the Second and Third Chapters of this Part; at present the facts are merely to be stated as they are observed.

The effects other than rise of temperature, produced by quantities of heat which disappear, can be used to measure and compare those quantities.

212. **Latent Heat of Expansion.**—Heat which disappears in causing the volume of a body to increase under a given pressure, has already been illustrated in the case of gases. For example, to raise the temperature of a pound of air one degree of Fahrenheit, and at the same time to increase its volume by 0·0020276 of its volume at 32°, requires $c_p = 0·238$ of a thermal unit; while the mere rise of temperature, without expansion, requires only $c_v = 0·169$; and it is evident that the difference between those quantities, or $c_p - c_v = 0·069$ of a thermal unit, is *the heat which disappears in producing the before-mentioned expansion*; or, in other words, the *latent heat of expansion* of the air, for an expansion of 0·0020276 of its volume under the same pressure at 32°.

The fact already mentioned, that the increase of the specific heat of solids and liquids as the temperature rises is greatest for those which are most expansible by heat, and in particular, the instance of that fact which takes place for water, whose least specific heat corresponds to its greatest density, makes it probable that the *variable part* of the specific heat of solids and liquids is *latent heat of expansion*; and that the *real specific heat* of every substance, or the heat which produces changes of temperature alone, is constant for all temperatures.

213. **Latent Heat of Fusion.**—When a body passes from the solid to the liquid state, its temperature remains stationary, or

nearly stationary, at a certain *melting point* (Art. 205) during the whole operation of melting; and in order to make that operation go on, a quantity of heat must be transferred to the substance melted, having a certain amount for each unit of weight of the substance. That heat does not raise the temperature of the substance, but *disappears* in causing its condition to change from the solid to the liquid state; and it is called the *latent heat of fusion*.

When a body passes from the liquid to the solid state, its temperature remains stationary or nearly stationary during the whole operation of freezing; a quantity of heat equal to the latent heat of fusion is produced in the body; and in order that the operation of freezing may go on, that heat must be transferred from the body to some other body.

The following are examples in British thermal units per lb. :—

Substances.	Melting points.	Latent heat of fusion.
Ice (according to Pelet),.....	32°	135
„ (according to Person),.....	32	142·65
Spermaceti,.....	56	148
Bees' wax,.....	140	175
Phosphorus,	177	9·06
Sulphur,.....	405	16·86
Tin,.....	426	500

M. Person, in a paper published in the *Annales de Chimie et de Physique*, for November, 1849, gives the following law as the result of his experiments on the latent heat of fusion of non-metallic substances:—

Let c be the specific heat of the substance in the solid state ;

c' , its specific heat in the liquid state ;

T , its temperature of fusion in Fahrenheit's ordinary scale ; then the latent heat of fusion of one pound, in British thermal units, is

$$l = (c' - c) (T + 256°) \dots \dots \dots (1.)$$

In the case of ice, for example, $c = 0·504$; $c' = 1$; $T = 32°$, and

$$l, \text{ by calculation, } \dots \dots \dots = \cdot 496 \times 288 = 142·86$$

$$l, \text{ by experiment, according to M. Person, } \dots \dots \dots = 142·65$$

$$\text{Difference, } \dots \dots \dots \quad \underline{\quad} \quad 0·21$$

M. Person also gives a general formula for the latent heat of fusion of metals, as to which it is sufficient here to refer the reader to the original paper cited.

The fusion of solids is sometimes used for the measurement of

quantities of heat. For example, an *ice calorimeter* consists essentially of a block of ice, in which a cavity has been made, with a stopper of ice for closing it. If a piece of some substance at a given temperature, higher than 32° , is enclosed in that cavity until its temperature falls to 32° , the quantity of heat transferred from it to the ice is indicated by the weight of ice melted, being at the rate of 142 British thermal units for each pound of ice melted.

The lowering of the melting point of ice by pressure, discovered by Mr. Thomson, will be described in Chapter III.

214. **Latent Heat of Evaporation.**—When a body passes from the solid or liquid to the gaseous state, its temperature during the whole operation remains stationary at a certain *boiling point* (Article 206) depending on the pressure of the vapour produced; and in order to make the evaporation go on, a quantity of heat must be transferred to the substance evaporated, whose amount, for each unit of weight of the substance evaporated, depends on the temperature. That heat does not raise the temperature of the substance, but *disappears* in causing it to assume the gaseous state; and it is called the *latent heat of evaporation*.

When a body passes from the gaseous state to the liquid or solid state, its temperature remains stationary, during that operation, at the boiling point corresponding to the pressure of the vapour; a quantity of heat equal to the latent heat of evaporation at that temperature is produced in the body; and in order that the operation of condensation may go on, that heat must be transferred from the body condensed to some other body.

The relations which exist between the latent heat of evaporation, and the pressure and volume of the vapour, will be explained in Chapter III.

The following are examples of the latent heat of evaporation in British thermal units, of one pound of certain substances, when the pressure of the vapour is *one atmosphere* of 14.7 lbs. on the square inch:—

Substance.	Boiling point under one atm. Fahr.	Latent heat in British units.	Authority.
Water,.....	$212^{\circ}0$	966.1	Regnault.
Alcohol,.....	$172^{\circ}2$	364.3	Andrews.
Æther,.....	$95^{\circ}0$	162.8	do.
Bisulphuret of carbon,.....	$114^{\circ}8$	156.0	do.

The latent heat of evaporation of water at a series of boiling points extending from a few degrees below its freezing point up to about 375° Fahrenheit has been determined experimentally by M. Regnault (*Memoirs of the Academy of Sciences*, 1847). The follow-

ing empirical formula represents the results of those experiments with great precision, in *British thermal units* :—

$$l = 1091.7 - 0.695 (T - 32^\circ) - 0.000000103 (T - 39^\circ.1)^3 \dots (1.)$$

This formula is not exactly the same with that given by M. Regnault himself, but is slightly modified for reasons explained in a paper on the specific heat of liquid water, in the *Transactions of the Royal Society of Edinburgh*, vol. xx. For the Centigrade scale, in *French units*, it becomes

$$l = 606.5 - 0.695 T - 0.00000033 (T - 4^\circ)^3 \dots (2.)$$

In most of the cases which occur in practice, it is sufficient to calculate the latent heat of evaporation of water by the following approximate formula :—

$$l \text{ nearly} = 1092 - 0.7 (T - 32^\circ) = 966 - 0.7 (T - 212^\circ) \dots (3.)$$

The latent heats of evaporation of other substances at pressures different from one atmosphere have not yet been ascertained.

215. **Total Heat of Evaporation**, or *total heat of vapour*, is a conventional phrase used to denote the sum of the heat which disappears in evaporating one pound of a given substance at a given temperature (or *latent heat of evaporation*), and of the heat required to raise its temperature, before evaporation, from some fixed temperature up to the temperature of evaporation. The latter part of the total heat is called the *sensible heat*.

To express this by symbols, let T_2 be the temperature at which the substance is originally obtained, T_1 that at which it is evaporated, c its mean specific heat between those temperatures, and l_1 its latent heat of evaporation at the temperature T_1 ; then its *total heat of evaporation, from T_2 , at T_1* , is thus expressed—

$$h_{2,1} = c (T_1 - T_2) + l_1 \dots (1.)$$

In formulæ and tables relating to the total heat of evaporation, it is usual to take for the original temperature T_2 , that of melting ice.

In the case of water, the experiments of M. Regnault, already referred to, led him to the discovery of the very simple law, that the *total heat of steam from the temperature of melting ice increases at an uniform rate as the temperature of evaporation rises*. The following is the formula by which that law is expressed, for *Fahrenheit's scale and British units* :—

$$h = 1091.7 + 0.305 (T - 32^\circ) ; \dots (2.)$$

which, for the *Centigrade scale and French units*, becomes

$$h = 606.5 + 0.305 T \dots (2 A.)$$

It is by subtracting from this expression the quantity of heat required to raise unity of weight of water from the temperature of melting ice to the temperature of evaporation T , as given in Article 209, that the formulæ 1 and 2 of Article 214 are obtained.

Let $c_{0,2}$ be the mean specific heat of water between the temperature of melting ice and the temperature T_2 of the "feed water" supplied to a boiler; then we have, for the total heat expended per pound of water evaporated from T_2 at T_1 , the following formula (in British units):—

$$h_{2,1} = 1091.7 + 0.305 (T_1 - 32^\circ) - c_{0,2} (T_2 - 32^\circ); \dots (3.)$$

the last term showing the diminution of the expenditure of the heat consequent upon the temperature of the feed water being $T_2 - 32^\circ$ higher than that of melting ice.

In most of the cases which occur in practice, small fractions may be neglected, and the specific heat of liquid water may be treated as constant, and = 1; so that the following approximate formulæ are in such cases sufficient:—

$$h = 1092 + 0.3 (T - 32^\circ) = 1146 + 0.3 (T - 212^\circ); \dots (4.)$$

$$h_{2,1} = 1092 + 0.3 (T_1 - 32^\circ) - (T_2 - 32^\circ) \dots \dots \dots (5.)$$

215 A. Measurement of Heat by Evaporation.—The heat produced by the combustion of a given weight of fuel (of which examples will be given in Chapter II.) is usually ascertained by finding what weight of water it evaporates. In such experiments, it is essential to the obtaining of accurate results that the temperature of the feed water and the temperature of evaporation should both be ascertained, and the total heat per pound of water computed; for which purpose the approximate formula 5 is sufficient. That total heat being divided by 966, the latent heat of evaporation of a pound of water at 212° , gives a *multiplier*, by which the weight of water actually evaporated by each pound of fuel is to be multiplied, to reduce it to the *equivalent evaporation from and at 212°* ; that is, *the weight of water which would have been evaporated by each pound of fuel, had the water been both supplied and evaporated at the boiling point corresponding to the mean atmospheric pressure.*

The weight of water so calculated is called the *evaporative power* of the fuel. To state it is, in fact, to employ a peculiar thermal unit,—viz., the latent heat of evaporation of one pound of water at 212° , which is 966 times greater than the ordinary British thermal unit. To exemplify the reduction above described, let the water be supplied to the boiler at 104° Fahr., and evaporated at 230° . Then by equation 5 of Article 15, the total heat of evaporation in common British units per pound of steam is (neglecting fractions),

$$h_{2,1} = 1092 + \frac{3}{10} : 198 - 72 = 1079;$$

and the multiplier by which the weight of water actually evaporated is to be multiplied to find the equivalent evaporation from and at 212°, is

$$\frac{1079}{966} = 1.117.$$

The following is a convenient form of the expression for that multiplier, or *factor of evaporation* :—

$$1 + \frac{0.3 (T_1 - 212^\circ) + (212^\circ - T_2)}{966}$$

The table on the next page gives the factor of evaporation as calculated by the above formula, for various temperatures of feed water and of boiling point.

216 B. Total Heat of Gasefication.—It is demonstrated by reasoning to be explained in Chapter III. that the total heat required to convert a given substance from a state of great density at a given temperature T_0 , to the *perfectly gaseous state* at a given temperature T_1 , the operation being completed under any constant pressure, is given by the equation

$$h = a + c' (T_1 - T_0), \dots \dots \dots (1.)^*$$

where a is a constant, and c' is the specific heat of the substance in the perfectly gaseous state, under constant pressure. For steam in the perfectly gaseous state, or *steam-gas*, as it may be called, for which

$$p_0 v_0 = 42141 \text{ foot-lbs.},$$

the best existing data give

$$\left. \begin{aligned} a &= 1092; \\ c' &= 0.475. \end{aligned} \right\} \dots \dots \dots (2.)$$

For example, to convert one pound of water at 32° into *steam-gas* at 212°, requires

$$1092 + .475 \times 180 = 1177$$

units of heat; being more than the quantity required to make saturated steam at the same temperature, in the ratio

$$\frac{1177}{1146} = 1.028.$$

* Equation 1 was first demonstrated for certain cases in 1849, in a paper published in the *Transactions of the Royal Society of Edinburgh*, vol. xx.; and was afterwards more generally demonstrated in a paper read to that Society in 1855, but not yet published.

TABLE OF FACTORS OF EVAPORATION.

Boiling Point, T ₁ , Fahr.	Initial Temperature of feed water, T ₂ .										
	32°	50°	68°	86°	104°	122°	140°	158°	176°	194°	212°
212°	1.19	1.17	1.15	1.13	1.11	1.10	1.08	1.06	1.04	1.02	1.00
230	1.20	1.18	1.16	1.14	1.12	1.10	1.08	1.06	1.04	1.02	1.01
248	1.20	1.18	1.16	1.14	1.13	1.11	1.09	1.07	1.05	1.03	1.01
266	1.21	1.19	1.17	1.15	1.13	1.11	1.09	1.07	1.06	1.04	1.02
284	1.21	1.20	1.18	1.16	1.14	1.12	1.10	1.08	1.06	1.04	1.02
302	1.22	1.20	1.18	1.16	1.14	1.12	1.11	1.09	1.07	1.05	1.03
320	1.22	1.21	1.19	1.17	1.15	1.13	1.11	1.09	1.07	1.05	1.03
338	1.23	1.21	1.19	1.17	1.15	1.14	1.12	1.10	1.08	1.06	1.04
356	1.23	1.22	1.20	1.18	1.16	1.14	1.12	1.10	1.08	1.06	1.04
374	1.24	1.22	1.20	1.18	1.17	1.15	1.13	1.11	1.09	1.07	1.05
392	1.24	1.23	1.21	1.19	1.17	1.15	1.13	1.11	1.09	1.07	1.06
410	1.25	1.23	1.22	1.20	1.18	1.16	1.14	1.12	1.10	1.08	1.06
428	1.25	1.24	1.22	1.20	1.18	1.16	1.14	1.12	1.11	1.09	1.07

SECTION 3.—*Of the Transfer of Heat.*

217. **Transfer of Heat in General.**—It has already been explained (Articles 196, 197), that equality of temperature between two bodies consists in the absence of any tendency to transfer of heat between them; and that when their temperatures differ, there is a tendency to equalize their temperatures, by the transfer of heat from the hotter to the colder. That tendency is the greater, the greater the difference between those temperatures.

The rate at which the transfer of heat takes place between two bodies, at unequal temperatures, depends—

First, on the tendency to transfer heat, increasing as some function of the two temperatures and their difference.

Secondly, on the areas of those parts of the surfaces of the bodies through which the transfer of heat takes place. In most of the cases which occur in practice, those areas are equal, and then the rate of transfer of heat is directly proportional to their common extent.

Thirdly, on the nature of the material of each of the bodies, and the condition of their surfaces.

Fourthly, on the nature and thickness of the intervening substances, if any. Increase of that thickness diminishes the rate of transfer of heat.

The transfer of heat takes place by three processes, called respectively, *radiation*, *conduction*, and *convection*.

218. **Radiation** of heat takes place between bodies at all distances apart, in the same manner and according to the same laws with the radiation of light. Its phenomena have been studied, and its laws ascertained, by many scientific inquirers; but for purposes connected with prime movers driven by means of heat, the exact and complete statement of those laws is unnecessary. It is sufficient to state, that the rate of radiation of heat by the hotter of a pair of bodies, and of its absorption by the colder, are increased by darkness and roughness of the surfaces of the bodies, and diminished by smoothness and polish.

219. **Conduction** is the transfer of heat between two bodies or parts of a body, which touch each other. It is distinguished into *internal* and *external* conduction, according as it takes place between the parts of one continuous body, or through the surface of contact of a pair of distinct bodies.

The rate at which conduction, whether internal or external, goes on, being proportional to the area of the section or surface through which it takes place, may be expressed in the form of *so many thermal units per square foot of area, per hour*.

The rate of *internal conduction* through a given substance, thus expressed, is proportional—

I. To the rate at which the temperature varies along a line perpendicular to the section through which the heat is transferred.

II. To a co-efficient called the *internal conductivity* of the substance, which depends on the nature of the substance. It also depends to a small extent on the temperature at the section under consideration, being in general somewhat greater at higher than at lower temperatures; but the law of its increase with temperature has not yet been accurately ascertained in any case; and it is usually treated as approximately constant.

Those laws are expressed mathematically as follows:—

Let dx denote the distance, in a direction perpendicular to a sectional plane through which heat is transferred, between a pair of points in a mass of a given substance;

dT , the difference between the temperatures of the mass of those points;

Then the rate of conduction through the given sectional plane may be represented by

$$q = k \cdot \frac{dT}{dx}; \dots\dots\dots(1.)$$

k being the co-efficient of conductivity. Now in cases where k without sensible error may be treated as constant, the above equation leads to the conclusion, that the rate of conduction through a *flat layer*, of any uniform thickness, is simply proportional, directly to the difference between the temperatures of the two faces of the layer, and inversely to its thickness; a principle expressed as follows:—

$$q = k \cdot \frac{T' - T}{x}; \dots\dots\dots(2.)$$

where T' and T are the temperatures at the two faces of the layer, and x its thickness. For reasons which will afterwards appear, it is convenient, in cases of this kind, instead of the conductivity k itself, to use its *reciprocal*, which may be called the *internal thermal resistance* of the substance, and may be represented as follows:—

$$e = \frac{1}{k}; \dots\dots\dots(3.)$$

so as to transform equation 2 into the following form:—

$$q = \frac{T' - T}{e x} \dots\dots\dots(4.)$$

The following are some values of the co-efficient of thermal resistance e , for different substances, when q is expressed in *thermal*

units per hour per square foot of area, and x in inches, as computed from a table of conductivities deduced by M. Peclet from experiments by M. Despretz :—

Gold, platinum, silver,..... $0\cdot0036$
Copper,..... $0\cdot0040$
Iron,..... $0\cdot0096$
Zinc,..... $0\cdot0099$
Lead,..... $0\cdot0198$
Marble,..... $0\cdot1578$
Brick,..... $0\cdot3306$

The total internal thermal resistance of a plate consisting of layers of different substances may be found by adding together the resistances of the several layers. Thus, let x denote the thickness of any one of those layers; ϵ , the co-efficient of thermal resistance of the substance of which it consists : let Σ , as usual, denote the summation of a set of quantities, so that $\Sigma \cdot x$, for example, is the total thickness of the compound plate ; then

$$\Sigma \cdot \epsilon x,$$

is the total thermal resistance of that plate, and

$$q = \frac{T' - T}{\Sigma \cdot \epsilon x}, \dots \dots \dots (5.)$$

the rate of conduction through it per square foot per hour, when T' and T are the temperatures of its hotter and cooler faces respectively.

The rate of *external conduction* through the bounding surface between a solid body and a fluid is approximately proportional to the difference of temperature, when that is small ; but when that difference is considerable, the rate of conduction increases faster than in the simple ratio of that difference, as will afterwards be shown more in detail.

The rate of external conduction may be expressed by dividing the difference of temperature by a co-efficient of *external thermal resistance*, depending on the nature of the substances, and also on their temperatures. Let the values of that co-efficient, for the two surfaces of a given plate, be denoted by σ' , σ , respectively ; let x be the thickness of the plate in inches, as before, and ϵ its co-efficient of internal thermal resistance ; then the total thermal resistance of the plate and of its two external surfaces is

$$\sigma' + \sigma + \epsilon x ;$$

and the rate of conduction through it is

$$q = \frac{T' - T}{\sigma' + \sigma + e} \dots\dots\dots (6.)$$

Where T' , T , are now the temperatures, not of the two surfaces of the plate, but of the two fluids which are respectively in contact with its two faces.

The external thermal resistance of the metal plates of boiler flues and tubes, and other apparatus used for heating and cooling fluids, is so much greater than the internal thermal resistance, that the latter is inappreciable in comparison; and, consequently, the nature and thickness of those plates has no appreciable effect on the rate of conduction through them.

The combined external thermal resistances of both surfaces of a plate, when one is in contact with a liquid and the other with air, have, according to M. Peclet, values capable of being expressed by the following formula:—

$$\sigma + \sigma' = \frac{1}{A \{1 + B(T' - T)\}} \dots\dots\dots (7.)$$

in which the constants depend chiefly on the condition of the surface of the body, and have the following values:—

B for polished metallic surfaces,.....	0.0028
B for rough metallic surfaces, and non-metallic surfaces,.....	0.0037
A for polished metals, about.....	0.4
A for glassy and varnished surfaces,.....	0.6
A for dull metallic surfaces,.....	0.7
A for lamp black,.....	0.8

When a metal plate has a liquid at each side of it, it appears from experiments by M. Peclet, that the constants in equation 7 take the following values:—

$$B = 0.058; \quad A = 4.0.$$

It will be shown in a subsequent Article, that the results of experiments on the evaporative power of boilers agree very well with the following approximate formula for the thermal resistance of boiler plates and tubes:—

$$\sigma' + \sigma = \frac{a}{T' - T} \dots\dots\dots (8.)$$

which gives for the rate of conduction, per square foot of surface per hour,

$$q = \frac{(T' - T)^2}{a} \dots\dots\dots (9.)$$

This formula is not proposed as being more than a rough approximation, but its simplicity makes it very convenient, and it will be shown that it is near enough to the truth for its purpose.

The value of α lies between 160 and 200.

220. **Convection or Carrying** of heat means the transfer and diffusion of the state of heat in a fluid mass by means of the motion of the particles of that mass.

The conduction, properly so called, of heat through a stagnant mass of fluid, is very slow in liquids, and almost, if not wholly, inappreciable in gases. It is only by the continual circulation and mixture of the particles of the fluid that uniformity of temperature can be maintained in the fluid mass, or heat transferred between the fluid mass and a solid body.

The laws of the cooling of thermometer bulbs by convection, when placed in receivers filled with different gases in different states as to pressure, were ascertained by Dulong and Petit; but the circumstances of the experiments were too unlike those which occur in boilers and furnaces to enable those laws to be used in the solution of questions connected with heat engines.

The free circulation of each of the fluids which touch the sides of a solid plate is a necessary condition of the correctness of the formulæ for the conduction of heat through that plate, which have been given in Article 219; and in each of those formulæ it is implied, that the circulation of each of the fluids by currents and eddies is such as to prevent any considerable difference of temperature between the fluid particles in contact with one side of the solid plate and those at considerable distances from it.

It is to promote that circulation, and so to insure uniformity of temperature in the fluid mass, that an agitator is employed in the water calorimeter, as already stated in Article 207 A. For a similar purpose, large boiler flues are sometimes provided with "*buffers*;" that is, projecting partitions which compel the hot gases to take a circuitous course, in order that eddies may be formed, so as to bring as many different particles as possible successively in contact with the heating surface. Those buffers, however, have also another object, which is to promote that thorough mixture of air with the inflammable gas from the fuel, which is necessary to complete combustion.

The most rapid convection of heat is that which is effected by means of cloudy vapour, which combines the mobility of a gas with the comparatively greater conducting power of a liquid; as when steam communicates heat to a solid body by condensing on its surface. Some data as to the rate at which this process goes on will be given in Article 222.

When heat is to be transferred by convection from one fluid to

another through an intervening layer of metal, the motions of the two fluid masses should if possible be in *opposite directions*, in order that the hottest particles of each fluid may be in communication with the hottest particles of the other, and that the *minimum* difference of temperature between the adjacent particles of the two fluids may be the greatest possible.

Thus in the surface condensation of steam, by passing it through metal tubes immersed in a current of cold water or air, the cooling fluid should be made to move in the opposite direction to the condensing steam.

In a steam boiler, it is favourable to economy of fuel that the motion of the water and steam should on the whole be opposite to that of the flame and hot gas for the furnace.

Thus, if there is a "feed-water heater," consisting of a set of tubes through which the water passes to be heated before entering the boiler, that apparatus should be placed in or near the foot of the chimney, so as to be heated by gas that has left the boiler, and thus to employ heat that would otherwise be wasted. The coolest, that is, the lowest portions of the water in the boiler, should, if practicable and convenient, be contiguous to the coolest parts of the furnace and heating surface; and if there is apparatus for *super-heating* the steam, or raising its temperature above the boiling point corresponding to its pressure, that apparatus will be most efficient if placed in the hottest part of the furnace, like that, for example, of Messrs. Parsons and Pilgrim.

221. **Efficiency of Heating Surface.**—When a layer of metal, lying between two flowing masses of fluid, serves as the means of transmitting heat from the hotter to the cooler of those masses, the proportion borne by the quantity of heat so transmitted to the whole quantity of heat which the hotter mass must lose in order to reduce it to the temperature of the colder mass, may be called the *efficiency* of the heating surface of that layer of metal.

In most of the cases that occur in practice, the layer of metal consists of the flues, tubes, and other portions of the solid material of a boiler which are exposed to heat; the cooler fluid is the water in the boiler, which is introduced by degrees in the liquid state at a low temperature, raised to a higher temperature, and evaporated; the hotter fluid is the stream of air and hot gases which comes from the furnace, flows along the heating surface, and finally escapes by the chimney.

Let W denote the weight of gas given out by the furnace in an hour; c its specific heat at constant pressure; $T - t$, the excess of its temperature above that of the water in the boiler when it is in contact with some given portion of the heating surface, the area of which portion is $d s$; let q denote the rate of conduction per

square foot of surface per hour, corresponding to the difference of temperature $T - t$; then

$$q \, d s$$

is the heat transmitted by the portion $d s$ of the heating surface from the hot gas to the water, and

$$\frac{q \, d s}{c' W} = - d T, \dots \dots \dots (1.)$$

is the lowering of the temperature of the gas by passing over the portion of heating surface $d s$. It arrives at the next elementary portion of heating surface with a diminished temperature, and the rate of conduction is therefore diminished; so that each successive equal portion of the heating surface transmits a less and a less quantity of heat, until the hot air at last leaves the heating surface and escapes up the chimney, with a certain remaining excess of temperature above that of the water in the boiler, the heat corresponding to which excess is wasted.

Let T_1 denote the temperature of the hot gas when it first comes in contact with the heating surface; T_2 its temperature when it finally leaves the heating surface; then

$$\left. \begin{array}{l} \text{the whole heat expended per hour is } c' W (T_1 - t); \\ \text{the heat wasted per hour} \qquad \qquad c' W (T_2 - t); \end{array} \right\} \dots \dots \dots (2.)$$

the efficiency of the heating surface,

$$\frac{T_1 - T_2}{T_1 - t}; \dots \dots \dots (3.)$$

and all those quantities are connected together by the equation 1, or by either of the following equations, which are different ways of expressing its integral :—

$$c' W (T_1 - T_2) = \int q \, d s; \dots \dots \dots (4.)$$

$$\frac{S}{c' W} = \int_{T_2}^{T_1} \frac{d T}{q}; \dots \dots \dots (5.)$$

in which last equation, S denotes the whole heating surface.

To represent these principles graphically, draw $\overline{A D}$, fig. 90, to represent the whole heating surface S ; and let any portion of that line, such as $\overline{A X}$, represent s , a part of that surface. Let the ordinate $\overline{A B} = q_1$, the rate of conduction for the initial temperature T_1 . In $D A$ produced, take

$$\overline{A O} = \frac{c' W (T_1 - t)}{q_1}; \dots\dots\dots(6.)$$

then the rectangle $\overline{O A} \cdot \overline{A B}$ will represent the whole heat expended per second.

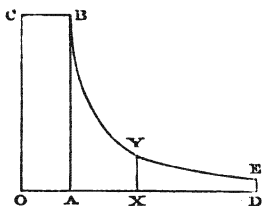

Fig. 90.

Let the ordinate $\overline{X Y} = q$ represent the rate of conduction corresponding to the temperature which the hot gas has after having passed over the portion $\overline{A X} = s$ of the heating surface, and let $B Y E$ be a curve drawn through the summits of a series of such ordinates; then the area of any part of that curve, such as $A B Y X$, represents the heat transferred per hour through the part s

of the heating surface; the area $A B E D$ represents the heat transferred per hour through the whole heating surface S ; and when the curve $B Y E$ is produced indefinitely, the area contained between it and its asymptote $A D$ approximates indefinitely to that of the rectangle $\overline{O A} \cdot \overline{A B}$.

The definite results of these principles depend on the relation between q and T .

CASE I.—If we assume Peclet's formula (Article 219, equation 0) for the thermal resistance of the plates, we find

$$q = A (T - t) \{1 + B (T - t)\}; \dots\dots\dots(7.)$$

and this value being introduced into equation 5, gives for the integral of that equation

$$\frac{S}{c' W} = \frac{1}{A} \cdot \text{hyp log} \left(\frac{T_1 - t}{T_2 - t} \cdot \frac{1 + B(T_2 - t)}{1 + B(T_1 - t)} \right); \dots\dots(8.)$$

and for the efficiency of the heating surface,

$$\frac{T_1 - T_2}{T_1 - t} = \frac{\left(e^{\frac{AS}{c'W}} - 1 \right) \cdot \{1 + B(T_1 - t)\}}{e^{\frac{AS}{c'W}} + \left(e^{\frac{AS}{c'W}} - 1 \right) B (T_1 - t)} \dots\dots\dots(9.)$$

The values of the constants A and B under different circumstances have been given in Article 219.

The value of $e^{\frac{AS}{c'W}}$ is easily found by the help of a table of hyperbolic logarithms, being the number whose hyperbolic logarithm is $A S \div c' W$.

CASE 2.—The above formula being too complex for ready use in practice, and the values of A and B being uncertain in furnaces at high temperatures, the supposition expressed in equations 8 and 9 of Article 219, viz, that the rate of conduction is nearly proportional to the square of the difference of temperature, has been tried, and found to agree well with experiment, as will afterwards be shown. That supposition gives as the integral of equation 5,

$$\frac{S}{c' W} = a \cdot \left\{ \frac{1}{T_2 - t} - \frac{1}{T_1 - t} \right\}; \dots\dots\dots (10.)$$

from which is easily deduced the following value of the efficiency of the heating surface :—

$$\frac{T_1 - T_2}{T_1 - t} = \frac{S (T_1 - t)}{S (T_1 - t) + a c' W} \dots\dots\dots (11.)$$

This may be put into another form, as follows :—Let H denote the expenditure of heat in an hour, in raising the temperature of the hot gas above that of the water; then

$$T_1 - t = \frac{H}{c' W}; \dots\dots\dots (12.)$$

and making this substitution in equation 11, we find for the efficiency of the surface,

$$\frac{S}{S + \frac{a c'^2 W^2}{H}} \dots\dots\dots (13.)$$

This result is represented graphically by taking, in fig. 90,

$$\overline{AO} = \frac{a c'^2 W^2}{H},$$

and making B Y E a hyperbola of the second order, with O D and O C for its asymptotes.

The values to be assigned to the constants in equation 13, will be investigated in Chapter II.

222. **Cooling Surface—Surface Condensation.**—The formulæ of the preceding Article, case 1, equations 8 and 9, are made applicable to cooling surfaces as follows :—Let t denote the temperature of a film of liquid, at one side of a metal plate; S, the extent of cooling surface, as before; let heat be communicated to the liquid at the temperature t by some such process as the condensation of steam, and let that be abstracted by the flow of a current of air,

water, or other fluid, in contact with the metal plate; the weight of fluid which flows past per second being W , its specific heat c' , its initial temperature T_1 , being lower than t , and its final temperature T_2 , still lower than t , but higher than T_1 . Then in all the equations $t - T_1$ is to be substituted for $T_1 - t$, and $t - T_2$ for $T_2 - t$.

An obstacle to the use of the formulæ as thus modified is, that the constants A and B have not yet been ascertained for the "surface condensation" of steam. It is only known that the *convection* of heat by a vapour in the act of condensing is more rapid than by substances in other conditions; and that in certain particular experiments on the surface condensation of steam, certain results have been obtained, of which the following are examples:—

Cooling fluid.	Its initial temperature T_1 Fahr.	Material of plates or tubes.	Steam condensed per square foot per hour. Lbs.	Authority.
Air,	59°	Cast iron.	0·36	Peclet.
"	"	Sheet iron,	0·36	"
"	"	Glass,	0·35	"
"	"	Copper,	0·28	"
"	"	Tin plate,	0·21	"
Water,	68° to 77°	Copper,	21·5	"
"	?	"	100·0	Joule.

In these experiments, each pound of steam may be estimated on an average as corresponding in round numbers to about 1,000 British thermal units.

The rapidity of the condensation depends mainly on that of the circulation of the cooling fluid at the other side of the plate.

CHAPTER II.

OF COMBUSTION AND FUEL.

223. **Total Heat of Combustion of Elements.**—Every chemical combination is accompanied by a production of heat: every decomposition, by a disappearance of heat, equal in amount to that which is produced by the combination of the elements which are separated. When a complex chemical action takes place, in which various combinations and decompositions occur simultaneously, the heat obtained is the excess of the heat produced by the combinations above the heat which disappears in consequence of the decompositions. Sometimes also, the heat produced is subject to a further deduction, on account of heat which disappears in melting or evaporating some of the substances which combine, either before or during the act of combination.

Combustion or *burning* is a rapid chemical combination. The only kind of combustion which is used to produce heat for driving heat engines, is the combination of fuel of different kinds with oxygen. In the ordinary sense of the word *combustible*, it means, *capable of combining rapidly with oxygen so as to produce heat rapidly*. By an *elementary* or *simple substance* is meant one which has never been decomposed.

The chief elementary combustible constituents of ordinary fuel are *carbon* and *hydrogen*. *Sulphur* is another combustible constituent of ordinary fuel; but its quantity and its heat-producing power are so small, that its presence is of no appreciable value.

Substances combine chemically in certain proportions only. To each of the substances known in chemistry a certain number can be assigned called its "*chemical equivalent*," having these properties— I. That the proportions by weight in which substances combine chemically can all be expressed by their chemical equivalents, or by simple multiples of their chemical equivalents. II. That the chemical equivalent of a compound is the sum of the chemical equivalents of its constituents.

Chemical equivalents are sometimes called *atomic weights*, or *atoms*, in accordance with the hypothesis that they are proportional to the weights of the supposed atoms of bodies, or *smallest similar parts* into which bodies are assumed to be divisible by known forces. The term *atom* is convenient from its shortness, and can be used to

mean "chemical equivalent," without necessarily affirming or denying the hypothesis from which it is derived, and which, how probable soever it may be, is, like other molecular hypotheses, incapable of absolute proof.

The chemical equivalents of substances in the perfectly gaseous state are known to be either exactly or very nearly proportional to their densities at the same pressure and temperature, or simple multiples or submultiples of those densities. In other words, perfect gases at a given pressure and temperature combine, either exactly or very nearly, in simple numerical proportions *by volume*. The volume of the compound also, if perfectly gaseous, bears always, either exactly or very nearly, some simple numerical ratio to the volumes of the constituents, at the same pressure and temperature.

These principles have already been illustrated in the case of the composition of steam, in Article 202.

The following are the chemical equivalents, according to the British scale, of the principal elementary constituents of fuel, and of the atmospheric air from which the oxygen required for combustion is derived, together with the symbols used in chemical writings to denote them, and their *chemical equivalents by volume* in the perfectly gaseous state:—

Name.	Symbol.	Chemical equivalent by weight.	Chemical equivalent by volume.
Oxygen,.....	O	8	$\frac{1}{2}$
Nitrogen,.....	N	14	1
Hydrogen,.....	H	1	1
Carbon,.....	C	6	?
Sulphur,.....	S	16	?

These numbers are given neglecting fractions too small to be of consequence for the purposes of the present treatise.

The composition of a compound substance is indicated in chemical writings, by affixing to the symbol of each element the number of its equivalents which enter into one equivalent of the compound.

The following table shows the composition of those compounds of the above elements which are of importance to the purposes of the present treatise, either as furnishing oxygen for combustion, as entering into the composition of ordinary fuel, or as being produced by the combustion of ordinary fuel:—

Name.	Symbol of chemical composition.	Proportions of elements by weight.	Chemical equivalent by weight.	Proportions of elements by volume.	Chemical equivalent by volume.
Air,.....	N_2O	N 28 + O 8	36	$N 2 + O \frac{1}{2}$	$2\frac{1}{2}$
Water,.....	HO	H 1 + O 8	9	$H 1 + O \frac{1}{2}$	1
Ammonia,.....	NH_3	H 3 + N 14	17		
Carbonic oxide,	CO	C 6 + O 8	14	$C ? + O \frac{1}{2}$	1
Carbonic acid,...	CO_2	C 6 + O 16	22	$C ? + O 1$	1
Olefiant gas,.....	C_2H_2	C 12 + H 2	14	$C ? + H 2$	1
Marsh gas, or fire damp,.. }	CH_2	C 6 + H 2	8	$C ? + H 1$	1

The last two substances are the chief ingredients of coal gas.

[There are numerous other compounds of hydrogen and carbon, known generally as "hydro-carbons," and comprising, amongst other substances, various fusible and volatile ingredients of coal; but it is unnecessary to give their chemical composition in detail.]

Sulphurous acid,.....	SO_2	S 16 + O 16	32		
Sulphuretted hydrogen,..	SH	S 16 + H 1	17	1	
Bisulphuret of carbon,...	S_2C	S 32 + C 6	38	1	

The French scale of equivalents differs from the British, principally in making the equivalents of oxygen and sulphur by weight double, as compared with the equivalents of most other elements, and in taking 100 to represent the equivalent of oxygen. Thus the symbol for water, according to the French system, is H_2O ; and its equivalent $(6.25 \times 2) + 100 = 112.5$.

The following table shows the total heat of combustion with oxygen of *one pound* of each of the elementary substances named in it, in British thermal units, and also in lbs. of water evaporated from 212° . It also shows the weight of oxygen required to combine with each pound of the combustible element, and the weight of air necessary in order to supply that oxygen. The quantities of heat are given on the authority of experiments made by MM. Favre and Silbermann with the mercurial calorimeter:—

Combustible.	Lb. oxygen per lb. of combustible.	Lb. air.	Total heat British units.	Evaporative power from 212° .
Hydrogen gas,.....	8	36	62,032	64.2
Carbon, imperfectly burned so as to make carbonic oxide,.....	} $1\frac{1}{3}$	} 6	} 4,400	} 4.55
Carbon, completely burned, so as to make carbonic acid,.....				
	} $2\frac{2}{3}$	} 12	} 14,500	} 15.0

It is to be observed, that the imperfect combustion of carbon, making carbonic oxide, produces *less than one-third* of the heat which is yielded by the complete combustion.

224. **Total Heat of Combustion of Compounds.**—The following is a similar table, on the same authority, for the more important *compound ingredients* of fuel:—

Combustible.	Lb. oxygen.	Lb. air.	Total heat British units.	Evaporative power from 212°.
Olefiant gas, 1 lb.,.....	3 $\frac{2}{3}$	15 $\frac{2}{3}$	21,344	22·1
Various liquid hydrocarbons, 1 lb.,.....	}	}	from 21,000	from 22
			to 19,000	to 20
Carbonic oxide, as much as is made by the imperfect combustion of 1 lb. of carbon, viz, 2 $\frac{1}{3}$ lbs.,.....	1 $\frac{1}{2}$	6	10,100	10·45

With regard to the quantities stated in this and the preceding Article as being the total heat of combustion respectively of carbon completely burned, carbon imperfectly burned, and carbonic oxide, the following explanation has to be made:—

The burning of carbon is always complete at first; that is to say, one pound of carbon combines with 2 $\frac{2}{3}$ lbs. of oxygen, and makes 3 $\frac{2}{3}$ lbs. of carbonic acid; and although the carbon is solid immediately before the combustion, it passes during the combustion into the gaseous state, and the carbonic acid is gaseous. This terminates the process when the layer of carbon is not so thick, and the supply of air not so small, but that oxygen in sufficient quantity can get direct access to all the solid carbon. The quantity of heat produced is 14,500 thermal units per lb. of carbon, as already stated.

But in other cases part of the solid carbon is not supplied directly with oxygen, but is first heated, and then dissolved into the gaseous state, by the hot carbonic acid gas from the other parts of the furnace. The 3 $\frac{2}{3}$ lbs. of carbonic acid gas from 1 lb. of carbon, are capable of dissolving an additional lb. of carbon, making 4 $\frac{2}{3}$ lbs. of *carbonic oxide* gas; and the volume of this gas is double of that of the carbonic acid gas which produces it. In this case, the heat produced, instead of being that due to the complete combustion of 1 lb. of carbon, or 14,500 falls to the amount due to the imperfect combustion of 2

lbs. of carbon, or..... 2 × 4,400 = 8,800

Showing a *loss* of heat to the amount of..... 5,700
which disappears in volatilizing the second pound of carbon. Should

the process stop here, as it does in furnaces ill supplied with air, the waste of fuel is very great. But when the $4\frac{3}{8}$ lbs. of carbonic oxide gas, containing 2 lbs. of carbon, is mixed with a sufficient supply of fresh air, it burns with a blue flame, combining with an additional $2\frac{3}{8}$ lbs. of oxygen, making $7\frac{1}{8}$ lbs. of carbonic acid gas, and giving additional heat of double the amount due to the combustion of $1\frac{1}{8}$ lb. of carbonic oxide; that is to say,

$$10,100 \times 2 = 20,200$$

to which being added the heat produced by the imperfect combustion of 2 lbs. of carbon, or 8,800

there is obtained the heat due to the complete combustion of 2 lbs. of carbon, or..... $2 \times 14,500 = 29,000$

If the total heat of combustion of olefiant gas be compared with that of its constituents taken separately, the result is as follows:—

$$\frac{6}{7} \text{ lb. carbon; } 14,500 \times \frac{6}{7} \dots\dots\dots = 12,430$$

$$\frac{1}{7} \text{ lb. hydrogen; } 62,032 \times \frac{1}{7} \dots\dots\dots = 8,862$$

Total heat of combustion of 1 lb. of olefiant gas as computed by adding together the quantities of heat produced by the combustion of its constituents separately,	} 21,292
As found by direct experiment,	} 21,344

The difference,..... 52

is within the limits of errors of observation.

Similar comparisons, for other hydrocarbons, give the same result. From these facts it is concluded, that *the total heat of combustion of any compound of hydrogen and carbon is the sum of the quantities of heat which the hydrogen and carbon contained in it would produce separately by their combustion.*

In computing by this rule the total heat of combustion of a compound, it is convenient to substitute for the hydrogen a quantity of carbon which would give the same quantity of heat; and this is done by multiplying the weight of hydrogen by

$$\frac{62,032}{14,500} = 4.28.$$

It appears from experiments by Dulong, by M. Despretz, and others, that in computing the total heat of combustion of compounds containing *oxygen* as well as hydrogen and carbon, the

following principle is to be observed:—*When hydrogen and oxygen exist in a compound in the proper proportion to form water (that is, by weight, very nearly, one part of hydrogen to eight of oxygen), these constituents have no effect on the total heat of combustion.*

It follows, that if hydrogen exists in a greater proportion than is necessary in order to form water with the oxygen, only the *surplus* of hydrogen above that which is required by the oxygen is to be taken into account.

From the preceding principles is deduced the following general formula for the total heat of combustion of any compound of which the principal constituents are carbon, hydrogen, and oxygen:—

Let C, H, and O, be the fractions of one pound of the compound which consists respectively of carbon, hydrogen, and oxygen; the remainder being nitrogen, ash, and other impurities.

Let h be the total heat of combustion of one pound of the compound, in British thermal units. Then

$$h = 14,500 \left\{ C + 4.28 \left(H - \frac{O}{8} \right) \right\} \dots\dots\dots(1.)$$

Let E denote the theoretical evaporative power of one pound of the compound, in pounds of water evaporated from and at 212° . Then

$$E = \frac{h}{966} = 15 \left\{ C + 4.28 \left(H - \frac{O}{8} \right) \right\} \dots\dots\dots(2.)$$

It has already been stated, that the values adopted in this treatise for the total heat of combustion of carbon and of hydrogen are taken from the experiments of MM. Favre and Silbermann.

In the case of hydrogen, the results of these experiments agree very closely with those of the experiments of Dulong (*Comptes Rendus*, vol. vii.), the total heat of combustion of one pound of hydrogen being,

According to Favre and Silbermann,.....	62,032	British units.
According to the mean of Dulong's ex-	} 62,536	" "
periments,.....		

In the case of carbon, the agreement amongst different experimenters is less close. The following is a comparison of some of the results given by them:—

Dulong (mean),.....	12,906
Despretz,.....	14,040
Favre and Silbermann,.....	14,500

The result arrived at by MM. Favre and Silbermann is adopted

in this treatise, because it was obtained by means of the mercurial calorimeter—an instrument from which great accuracy may be expected—and because amongst a number of different results as to total heat of combustion, the highest is on the whole the most likely to be correct, most of the errors being caused by losses of heat.

225. **Kinds and Ingredients of Fuel.**—The ingredients of every kind of fuel commonly used may be thus classed:—

(I.) *Fixed or free carbon*, which is left in the form of charcoal or coke after the volatile ingredients of the fuel have been distilled away. This ingredient burns either wholly in the solid state, or part in the solid state and part in the gaseous state, the latter part being first dissolved by previously formed carbonic acid, as already explained.

(II.) *Hydrocarbons*, such as olefiant gas, pitch, tar, naphtha, &c., all of which must pass into the gaseous state before being burned.

If mixed on their first issuing from amongst the burning carbon with a large quantity of air, these inflammable gases are completely burned with a transparent blue flame, producing carbonic acid and steam. When raised to a red heat, or thereabouts, before being mixed with a sufficient quantity of air for perfect combustion, they disengage carbon in fine powder, and pass to the condition partly of marsh gas, and partly of free hydrogen; and the higher the temperature, the greater is the proportion of carbon thus disengaged.

If the disengaged carbon is cooled below the temperature of ignition before coming in contact with oxygen, it constitutes, while floating in the gas, SMOKE, and when deposited on solid bodies, SOOT.

But if the disengaged carbon is maintained at the temperature of ignition, and supplied with oxygen sufficient for its combustion, it burns while floating in the inflammable gas, and forms RED, YELLOW, or WHITE FLAME. The flame from fuel is the larger, the more slowly its combustion is effected.

(III.) *Oxygen and hydrogen* either actually forming water, or existing in combination with the other constituents in the proportions which form water. According to a principle already stated, such quantities of oxygen and hydrogen are to be left out of account in determining the heat generated by the combustion. If the quantity of water actually or virtually present in each pound of fuel is so great as to make its latent heat of evaporation worth considering, that heat is to be deducted from the total heat of combustion of the fuel.

The presence of water, or its constituents, in fuel, promotes the formation of smoke, or of the carbonaceous flame, which is ignited smoke, as the case may be, probably by mechanically sweeping along fine particles of carbon.

(IV.) *Nitrogen*, either free or in combination with other constituents. This substance is simply inert.

(V.) *Sulphuret of iron*, which exists in coal, and is detrimental, as tending to cause spontaneous combustion.

(VI.) *Other mineral compounds* of various kinds, which are also inert, and form the *ASH* left after complete combustion of the fuel, and also the *clinker*, or glassy material produced by fusion of the ash, which tends to choke the grate.

226. **Kinds of Fuel.**—The kinds of fuel in common use may be thus classed :—I. Charcoal; II. Coke; III. Coal; IV. Peat; V. Wood.

I. *Charcoal* is made by evaporating the volatile constituents of wood and peat, either by a partial combustion of a conical heap of the material to be charred, covered with a layer of earth, or by the combustion of a separate portion of fuel in a furnace, in which are placed retorts containing the material to be charred.

According to Pelet, 100 parts by weight of wood when charred in a heap, yield from 17 to 22 parts by weight of charcoal, and when charred in a retort, from 28 to 30 parts.

This has reference to the ordinary condition of the wood used in charcoal making, in which 25 parts in 100 consist of moisture. Of the remaining 75 parts, the carbon amounts to one-half, or $37\frac{1}{2}$ per cent. of the gross weight of the wood. Hence it appears that on an average nearly half of the carbon in the wood is lost during the partial combustion in a heap, and about one quarter during the distillation in a retort.

To char 100 parts by weight of wood in a retort, $12\frac{1}{2}$ parts of wood must be burned in the furnace. Hence in this process, the whole expenditure of wood to produce from 28 to 30 parts of charcoal, is $112\frac{1}{2}$ parts; so that if the weight of charcoal obtained is compared with the whole weight of wood expended, its amount is from 25 to 27 per cent.; and the proportion of carbon lost is on an average $11\frac{1}{2} \div 37\frac{1}{2} = 0.3$ nearly.

According to Pelet, good wood charcoal contains about 0.07 of its weight of ash. The proportion of ash in peat charcoal is very variable, and is estimated on an average at about 0.18.

II. *Coke* is the solid material left after evaporating the volatile ingredients of coal, either by means of partial combustion in furnaces called coke ovens, or by distillation in the retorts of gas-works.

Coke made in ovens is preferred to gas coke as fuel. It is of a dark grey colour, with slightly metallic lustre, porous, brittle, and hard.

The proportion of coke yielded by a given weight of coal is very different for different kinds of coal, ranging from 0.9 to 0.35.

Coke contains from 0·06 to 0·18 of its weight of ash, the remainder being carbon.

Being of a porous texture, it readily attracts and retains water from the atmosphere; and sometimes, if it is kept without proper shelter, from 0·15 to 0·20 of its gross weight consists of moisture.

III. *Coal*.—The extreme differences in the chemical composition and properties of different kinds of coal are very great; but the number of those kinds is very great, and the gradations of their differences are small.

The proportion of free carbon in coal ranges from 30 to 93 per cent.; that of hydrocarbons of various kinds from 5 to 58 per cent.; that of water, or oxygen and hydrogen in the proportions which form water, from an inappreciably small quantity to 27 per cent.; that of ash, from $1\frac{1}{2}$ to 26 per cent.

The numerous varieties of coal may be divided into principal classes as follows:—

1. Anthracite or blind coal.
2. Dry bituminous coal.
3. Caking coal.
4. Long flaming or cannel coal.
5. Lignite or brown coal.

(1.) *Anthracite* or *blind coal* consists almost entirely of free carbon. It has a colour intermediate between jet black and the greyish-black of plumbago, and a lustre approaching to metallic.

Its specific gravity is from 1·4 to 1·6, that of water being 1.

It burns without smoke, and, when dry, without flame also; but the presence of moisture in it produces small yellowish flames, in the manner explained in Article 225.

It requires a high temperature, and in general a blast produced by mechanism, for its combustion. If suddenly heated, it splits into small pieces, which are liable to fall through the grate bars of the furnace and be lost. In furnaces where it is used, therefore, each fresh portion should be gradually heated before being ignited.

(2.) *Dry bituminous coal* contains on an average from 70 to 80 per cent. of free carbon, about 5 per cent. of hydrogen, and 4 per cent. of oxygen; so that $5\frac{1}{2}$ per cent. of hydrogen is available to produce heat. This hydrogen exists in combination with part of the carbon. Such coal burns with a moderate amount of flame, and little or no smoke. Its average specific gravity is about 1·3.

(3.) *Bituminous caking coal* contains on an average from 50 to 60 per cent. of free carbon, and about equal weights of hydrogen and oxygen, amounting to from 10 to 12 per cent. of its weight. It softens when exposed to heat, and pieces of it adhere together. It produces more flame than dry bituminous coal, and also produces

smoke, unless that is prevented by special means. Its average specific gravity is about 1.25.

(4.) *Long flaming coal* differs from the last variety chiefly in containing more oxygen. In some examples it softens and cakes in the fire; in others not. It requires special means for the prevention of smoke.

(5.) *Brown coal, or lignite*, is found in more recent strata than any of the preceding kinds. It is intermediate in appearance and properties between them and peat. It contains on an average from 27 to 50 per cent. of free carbon, about 5 per cent. of hydrogen, and 20 per cent. of oxygen. Its specific gravity is from 1.20 to 1.25.

With respect to the different kinds of coal, M. Peclet makes a remark to the effect, that the caking bituminous coals pass to the dry coals and to anthracite by diminution of their oxygen and hydrogen, and to the long flaming coals and lignites by the augmentation of their oxygen.

From the specific gravities already stated, it appears that a cubic foot of solid coal weighs from 70 to 90 lbs.; but coal in pieces, such as are commonly used for feeding furnaces, including the spaces between the pieces, occupies from $1\frac{3}{8}$ to $1\frac{4}{8}$ times the space that the same coal fills in a continuous mass; so that the average weight of coals, including the space between the pieces, is about 52 lbs. per cubic foot. In a few examples it is as high as 56 or 60 lbs. to the cubic foot.

IV. *Peat, or turf*, as usually dried in the air, contains from 25 to 30 per cent. of water, which must be allowed for in estimating its heat of combustion. This water having been evaporated, the analysis of M. Regnault gives, in 100 parts of perfectly dry peat of the best quality—

Carbon,	58
Hydrogen,	6
Oxygen,	31
Ash,	5
	100

In some other examples of peat, the quantity of ash is greater, amounting to 7 and sometimes to 11 per cent.

The specific gravity of peat in its ordinary state is about 0.4 or 0.5. It can be compressed by machinery to a much greater density.

V. *Wood*, when newly felled, contains a proportion of moisture which varies very much in different kinds and in different specimens, ranging between 30 and 50 per cent., and being on an average about 40 per cent. After eight or twelve months' ordinary drying in the air, the proportion of moisture is from 20 to 25 per

cent. This degree of dryness, or almost perfect dryness if required, can be produced by a few days' drying in an oven supplied with air at about 240° Fahrenheit. When coal or coke is used as the fuel for that oven, 1 lb. of fuel suffices to expel about 3 lbs. of moisture from the wood. This is the result of experiments on a large scale by Mr. J. R. Napier. If air-dried wood were used as fuel for the oven, from 2 to 2½ lbs. of wood would probably be required to produce the same effect.

The specific gravity of different kinds of wood ranges from 0.3 to 1.2.

Perfectly dry wood contains about 50 per cent. of carbon, the remainder consisting almost entirely of oxygen and hydrogen in the proportions which form water. The coniferous family contain a small quantity of turpentine, which is a hydrocarbon. The proportion of ash in wood is from 1 to 5 per cent. The total heat of combustion of all kinds of wood, when dry, is almost exactly the same, and is that due to the 50 per cent. of carbon.

227. **The Total Heat of Combustion** of fuel is computed from its chemical composition, according to the principles explained in Articles 223, 224, and 225. The following table gives the results of such computations, founded chiefly on the analyses of M. Regnault, Dr. Playfair, and Professor Richardson. The numerous kinds of fuel of which analyses have appeared have been classed in groups, and the *average* chemical composition of each group computed. By this process have been obtained the proportions of carbon, hydrogen, and oxygen, given in the columns headed C, H, and O, respectively.

The column headed C' shows the weight of pure carbon whose total heat of combustion would be the same with that of the fuel, as given by the formula

$$C' = C + 4.28 \left(H - \frac{O}{8} \right).$$

$E = 15 C'$ is the theoretical evaporative power in pounds of water supplied and evaporated at 212° by one pound of fuel.

$h = 14500 C'$ is the total heat of combustion in pounds of water raised one degree of Fahrenheit.

Each kind of fuel is supposed to be *perfectly dry*, unless otherwise specified:—

TABLE OF THE TOTAL HEAT OF COMBUSTION OF FUEL.

FUEL	C.	H.	O.	C.	E.	h.
I. CHARCOAL—						
from wood, }	0·93			0·93	14	13500
„ from peat,				0·80	12	11600
II. COKE—good,...	0·94			0·94	14	13620
„ middling,	0·88			0·88	13·2	12760
„ bad,.....	0·82			0·82	12·3	11890
III. COAL—						
1. Anthracite,...	0·915	0·035	0·026	1·05	15·75	15225
2. Dry bitu- minous,.... }	0·90	0·04	0·02	1·06	15·9	15370
3. „ „	0·87	0·04	0·03	1·025	15·4	14860
4. „ „	0·80	0·054	0·016	1·02	15·3	14790
5. „ „	0·77	0·05	0·06	0·95	14·25	13775
6. Caking,.....	0·88	0·052	0·054	1·075	16·0	15837
7. „	0·81	0·052	0·04	1·01	15·15	14645
8. Cannel,.....	0·84	0·056	0·08	1·04	15·6	15080
9. Dry long } flaming,.... }	0·77	0·052	0·15	0·91	13·65	13195
10. Lignite,.....	0·70	0·05	0·20	0·81	12·15	11745
IV. PEAT—dry,...	0·58	0·06	0·31	0·66	10·0	9660
„ contain- ing 25 per c. moisture, ... }					7·25	7000
V. WOOD—dry,...	0·50			0·50	7·5	7245
„ contain- ing 20 per c. moisture, ... }					5·8	5600

With respect to the examples of coal given in this table, it is to be observed that they are all of good quality, as it has never been the practice to submit bad coals to chemists for analysis. It may be estimated, that the total heat of combustion of the worst coal in a given coal field is about *two-thirds* of that of the best, the difference arising chiefly from the proportion of earthy matter.

228. **Radiation from Fuel.**—The proportion which the heat radiated from incandescent fuel bears to the total heat of combustion has been determined for some kinds of fuel by the experiments of M. Peclet, with the following results:—

From wood,.....0·29
From charcoal and peat,.....0·5

From coal and coke M. Peclet considers that the radiation must be greater than from charcoal, although he has not ascertained it precisely.

The practical conclusion to be drawn from this fact is, that the radiation from the fuel in the furnace of a heat engine ought to be carefully intercepted in every direction, in such a manner that the heat diffused by it may be communicated either directly or indirectly to the substance to be heated. The means used for effecting this are various. One of the simplest is to have the furnace wholly contained in a flue or fire box inside the boiler. Another is, to surround all those parts of the furnace whose radiation is not directly intercepted by the boiler, with brickwork so thick as not to admit of any material loss of heat by conduction. The resistance to conduction is greatly increased by having two, or three, successive layers of brickwork with air spaces between, such spaces being completely closed, in order that the air in them may not circulate. Two such layers of fire-brick, the inner 9 inches thick, the outer $4\frac{1}{2}$, with an air space 3 inches thick between them, have been found to answer in practice. The great resistance of this coating to the transmission of heat causes the inner surface of the inner layer, which directly receives the radiation of the fire, to rise to a white heat, or nearly so, and almost the whole of the heat which it receives is, because of that high temperature and the rapid circulation of the furnace gases over it, carried off by those gases, and made available for communication to the boiler.

The heat which is radiated down between the grate bars is intercepted by the sides and floor of the ash pit, and carried back to the furnace by the air which enters through the ash pit.

To prevent loss by radiation and conduction through the furnace door, the simplest plan is that used by Mr. Williams and others, of making it of two layers of cast iron plates, with an air space between. The plates are usually perforated with small holes for the admission of air to burn the gaseous ingredients of fuel, and care is to be taken to place no two of those holes opposite each other. Thus the heat which is radiated through the holes in the inner plate is intercepted by the outer plate. The greater part of the heat thus received by the plates is carried back into the furnace by the entering stream of air. To intercept the heat and give it out to the entering air more completely, a series of sheets of wire gauze have sometimes been interposed between the outer and inner surfaces of a perforated furnace door.

The most complete apparatus for intercepting the heat radiated to the furnace door is that of Mr. Prideaux, which consists of three gratings, each made of a series of thin iron plates set edgewise, with narrow passages between them for the entering stream of air. The

radiant heat is completely intercepted by placing two of those sets of plates with opposite obliquities, and the third parallel to the sides of the furnace mouth-piece.

229. **Air required for Combustion and Dilution.**—The number of pounds of air required in order to supply the oxygen necessary for the combustion of one pound of any sort of fuel whose chemical composition is known, may be computed by the aid of the data given in Article 223, at the foot of page 269.

To express that weight symbolically, let it be denoted by A; then, C, H, and O, having the same meanings as before,

$$A = 12 C + 36 \left(H - \frac{O}{8} \right) \dots\dots\dots(1.)$$

The following are a few of the results:—

FUEL.	C.	H.	O.	A.
I. CHARCOAL—from wood, ...	0·93			11·16
„ from peat,.....	0·80			9·6
II. COKE—good,.....	0·94			11·28
III COAL—anthracite,.....	0·915	0·035	0·026	12·13
„ dry bituminous,	0·87	0·05	0·04	12·06
„ caking,.....	0·85	0·05	0·06	11·73
„ „	0·75	0·05	0·05	10·58
„ cannel,.....	0·84	0·06	0·08	11·88
„ dry long flaming,	0·77	0·05	0·15	10·32
„ lignite,.....	0·70	0·05	0·20	9·30
IV. PEAT—dry,.....	0·58	0·06	0·31	7·68
V. WOOD—dry,.....	0·50			6·00

It is unnecessary for practical purposes to compute the air required for the combustion of fuel to a great degree of exactness; and no material error is produced if the air required for the combustion of every kind of *coal* and *coke* used for furnaces is estimated at *twelve pounds per pound of fuel*.

Besides the air required to furnish the oxygen necessary for the complete combustion of the fuel, it is also necessary to furnish an additional quantity of air for the *dilution* of the gaseous products of combustion, which would otherwise prevent the free access of air to the fuel.

The more minute the division, and the greater the velocity with which the air rushes amongst the fuel, the smaller is the additional quantity of air required for dilution.

From the various experiments, especially those made for the

American government by Mr. Johnson, it appears that in ordinary boiler furnaces, where the draught is produced by means of a chimney, the weight of air required for dilution is equal to that required for combustion; so that if A' denotes the total weight of air to be supplied to the furnace per lb. of fuel,

$$A' = 2 A = 24 \text{ lbs. nearly} \dots\dots\dots(2.)$$

But in furnaces where the draught is produced by means of a blast pipe, like those of locomotive engines, or by means of a fan, the quantity of air required for dilution, although it has not yet been exactly ascertained, is certainly much less than that which is required in furnaces with chimney draughts; and there is reason to believe that on an average it may be estimated at about *one-half* of the air required for combustion; so that in this case,

$$A' = \frac{3}{2} A = 18 \text{ lbs. nearly} \dots\dots\dots(3.)$$

This estimate is roughly made; but it is the nearest approximation at present attainable. It is probable that the supply of air required for dilution varies considerably in different arrangements of furnace, and for different kinds of fuel; and it is possible, that by blowing the air for combustion into a furnace in small enough jets, and with sufficient force, air for dilution might be rendered unnecessary, so that A' would be = A .

An insufficient supply of air causes imperfect combustion of the fuel, which in bituminous coal is indicated by the production of smoke, and in coke and blind coal by the discharge of carbonic oxide gas from the chimney. That gas is transparent and invisible; but its presence may be detected by the blue or purple flame with which it burns when ignited in contact with fresh air.

An excessive supply of air causes waste of heat to the amount corresponding to the weight of air in excess of that which is necessary, and to the elevation of the temperature at which it is discharged from the chimney above that of the external air.

230. **Distribution of Fuel and Air.**—In burning charcoal, coke, and coals which contain a small proportion only of hydrocarbons, a supply of air sufficient for complete combustion will enter from the ash pit through the bars of the grate, provided there is a sufficient draught, and that care is taken to distribute the fresh fuel evenly over the fire, and in moderate quantities at a time, so that the thickness of the layer of burning fuel shall never differ much from ten or twelve inches.

To insure the complete combustion of highly bituminous coal, other means have to be adopted. That invented by Watt was the

use of a *dead plate*; that is, a horizontal or slightly inclined plate at the mouth of the furnace, without perforations, on which each fresh charge of coal is laid, until the hydrocarbons are volatilized and expelled by the radiant heat of the fire. The layer of burning fuel on the grate being thin at the time when a fresh charge is needed, more air passes through it from the ash pit than is necessary for its own combustion, and the surplus serves to burn the inflammable gas as it passes above the grate. When the coal on the dead plate has been reduced to coke, it is pushed inwards and spread over the fire. The success of this process depends wholly on the care and skill of the fireman. It is useful not only to promote complete combustion, but to prevent the clogging of the bars by caking coal.

In burning anthracite, a dead plate is useful for a different purpose, viz., to heat the fuel gradually; because sudden heating makes it fly into small pieces, which drop through the bars into the ash pit, and are partly wasted.

In the double furnace with alternate firing, introduced by Mr. Fairbairn, the gas distilled from the fresh fuel in one of a pair of furnaces is burned by the excess of air which passes through the red coke on the grate of the other furnace.

Another mode of insuring the complete combustion of the volatile parts of the coal is one of which various forms have been invented by Mr. C. W. Williams, Mr. Prideaux, Mr. Clark, and others, and consists in admitting air *above* the fuel to burn the gas, and *below* it to burn the coke.

Mr. Williams admits air at a constant rate through perforations in a double door and double front. In the latest practical examples, the total area of these perforations is $\frac{1}{16}$ of the area of the grate, when 25 lbs. of coal are burned per hour on the square foot of grate; that is, when the area of the grate in square feet is $\frac{1}{16}$ of the number of lbs. of coal burned per hour, the joint area of the air holes is $\frac{1}{16}$ of the same number.

Mr. Prideaux uses a self-acting apparatus for the admission of air, like a Venetian blind, which is opened when fresh coal is supplied, and which gradually closes as the gas of the fresh fuel becomes exhausted. The object of this is to supply enough of air at the time when it is needed, and to prevent an excessive supply at other times. Mr. D. K. Clark, by steam jets, blows in jets of air through holes immediately above the fuel.

According to a method which seems to have been first used in America, a fan blower blows air through two sets of nozzles, one opening into the ash pit, which is closed in front, and the other into the furnace, immediately above the fuel.

Mr. Gorman opens and closes the front of the ash pit, and the

air holes in the front of the furnaces, alternately, so that the combustion of the gas from the fresh fuel, and of the coke left after its expulsion, take place alternately.

Dr. Marsh supplies the whole of the air for burning the coke as well as the gas, by jets directed downwards on the fuel from above.

Incomplete combustion of fuel is often caused by the chilling and extinguishing of flame through contact with the surface of the boiler, before the combustion is completed. This is in some furnaces prevented by completing the combustion in fire-brick chambers or passages. For example, in the furnaces introduced by Mr. Charles Tennant & Company, the combustion is completed in an arched brick oven or reverberatory furnace, before the hot gas comes in contact with any part of the boiler. The sides and roof of that oven consist of two layers of fire-brick with a closed air space between, as already described in Article 228.

In many furnaces the principles of the various contrivances beforementioned are combined; thus double furnaces are used with air holes in the front, and with fire-brick combustion chambers. The coal burning locomotive furnaces of various inventors are of this class. Various furnaces have been used, such as Juckes's, in which the fuel is supplied at an uniform rate by mechanism.

In the apparatus known by the name of the "Système Beau-fumé," a partial combustion of the fuel is effected in a furnace surrounded by a water chamber, and supplied by a fan with just enough of air to form *carbonic oxide* with the whole of the free carbon, and volatilize the whole of the hydrocarbons, so that the whole of the fuel is gasefied except the ash. The mixture of carbonic oxide and hydrocarbon gases thus produced is conducted by a pipe to a combustion chamber, where, by the introduction of jets of air of sufficient volume, it is completely burned.

If smoke is mixed with carbonic acid gas at a red heat, the solid carbonaceous particles are dissolved in the gas, and carbonic oxide is produced. This is the mode of operation of contrivances for destroying smoke by keeping it at a high temperature, without providing a sufficient supply of air; and the result is a waste, instead of a saving of fuel.

The details of the construction of various furnaces will be further considered in a subsequent chapter.

231. **Temperature of Fire.**—By the *temperature of the fire* is here understood the temperature of the products of combustion, and the air with which they are mixed, at the instant that the combustion is complete. The elevation of that temperature above the temperature at which the air and fuel are supplied to the furnace may be computed, by dividing the total heat of combustion of one lb. of

fuel by the weight and by the specific heat of the whole products of its combustion, and of the air employed for their dilution, under constant pressure.

The specific heat, under constant pressure,

Of carbonic acid gas is	0·217
Of steam,	0·475
Of nitrogen (probably),	0·245
Of air,	0·238
Of ashes, probably about	0·200

By using these data, the following results are obtained for the two extreme cases of *pure carbon* and *olefiant gas*, burned respectively in air: *—

Fuel,	CARBON.	OLEFIANT GAS.
Total heat of combustion per lb.,	14,500	21,300
Weight of products of combustion in } air, undiluted,	13 lbs.	16·43 lbs.
Their mean specific heat,	0·237	0·257
Specific heat \times weight,	3·08	4·22
Elevation of temperature if undiluted,	4580°	5050°

If diluted with air = $\frac{1}{2}$ air for combustion—

Weight per lb. of fuel,	19	24·2
Mean specific heat,	0·237	0·25
Specific heat \times weight,	4·51	6·06
Elevation of temperature,	3215°	3515°

If diluted with air = air for combustion—

Weight per lb. of fuel,	25	31·86
Mean specific heat,	0·238	0·248
Specific heat \times weight,	5·94	7·9
Elevation of temperature,	2440°	2710°

It appears from these calculations that the mean specific heat of the products of combustion of furnaces differs very little from that of air when they are undiluted, and still less when they are diluted with air.

232. **Rate of Combustion.**—The weight of fuel which can be burned in a given time in a given furnace depends on the *draught*, or quantity of air, which is made to pass through that furnace in a given time, and may be computed by dividing the weight of that

* These calculations are made according to the same principles with those of Mr. Prideaux in his treatise on *Economy of Fuel*, Section VI.; but there are some differences in the data, especially as to the specific heat of steam, which lead to differences (though not great ones) in the numerical results.

air by the proportion which that weight bears to the weight of fuel which it can completely burn, according to the principles of Article 229.

The rate of combustion of coal in a furnace is usually stated in *pounds per hour, burned on each square foot of grate*. The following are examples:—

I. WITH CHIMNEY DRAUGHT.

	Lbs. per square foot per hour.
1. The slowest rate of combustion in Cornish boilers,	4
2. Ordinary rate in these boilers,	10
3. Ordinary rates in factory boilers,	12 to 16
4. Ordinary rates in marine boilers,	16 to 24
5. Quickest rates of complete combustion of dry coal, the supply of air coming through the grate only,	} 20 to 23
6. Quickest rates of complete combustion of cak- ing coal, with air holes above the fuel to the extent of $\frac{1}{8}$ area of grate,	} 24 to 27

II. WITH DRAUGHT PRODUCED BY BLAST PIPE OR FAN.

7. Locomotives,	40 to 120
-----------------------	-----------

233. **Draught of Furnaces.** — The draught of a furnace, or quantity of mixed gas which it discharges in a given time, may be estimated either by weight or by volume; or it may be expressed by means of the velocity of the current at some particular point; or by the pressure required to produce that current.

When either the whole or part of the oxygen in a given weight of air, at a given temperature, combines with carbon so as to form carbonic acid, the volume of the mixed gas produced is the same with the original volume of the air; and the density is increased simply in the ratio of the sum of the weights of the air and of the carbon to the weight of the air.

When the whole or part of the oxygen of a given weight of air combines with hydrogen so as to form steam, the volume of the mixed gas produced is greater than the original volume of the air by an amount equal to one-half of the volume of the hydrogen taken up.

But the hydrogen in ordinary fuel bears so small a proportion to the whole weight, that in calculations for practical purposes, the volume at any given temperature of the gas which a furnace discharges may be treated without sensible error as being equal to the volume at the same temperature of the air with which it is supplied.

The variations of density produced by deviations of the pressure of the furnace gas from the mean atmospheric pressure may also be neglected in practice; so that its *volume at 32° Fahrenheit* may be estimated approximately at 12½ cubic feet for each lb. of air supplied to the furnace; or, if the supply of air be

	Volume at 32° per lb. of fuel.
12 lbs. per lb. of fuel,.....	150 cubic feet.
18 " " 	225 " "
24 " " 	300 " "

The volume at any other temperature T is

$$V = \text{volume at } 32^\circ \times \frac{T + 461^{\circ}.2}{493^{\circ}.2} = V_0 \cdot \frac{\tau}{\tau_0} \dots\dots(1.)$$

The following are some of the results:—

	Supply of air in lbs. per lb. of fuel.		
	12	18	24
Temperatura.	Volume of gases per lb. of fuel in cubic feet.		
4640°	1551		
3275°	1136	1704	
2500°	906	1359	1812
1832°	697	1046	1395
1472°	588	882	1176
1112°	479	718	957
752°	369	553	738
572°	314	471	628
392°	259	389	519
212°	205	307	409
104°	172	258	344
68°	161	241	322
32°	150	225	300

Let *w* denote the weight of fuel burned in a given furnace *per second*;

*V*₀, the volume at 32° of the air supplied per lb. of fuel;

*τ*₁, the absolute temperature of the gas discharged by the chimney;

A, the sectional area of the chimney; then the velocity of the current in the chimney in feet per second is

$$u = \frac{w V_0 \tau_1}{A \tau_0} ; \dots\dots\dots(2.)$$

and the density of that current, in lbs. to the cubic foot, is very nearly

$$D = \frac{\tau_0}{\tau_1} \left(0.0807 + \frac{1}{V_0} \right); \dots \dots \dots (3.)$$

that is to say, from 0.084 to $0.087 \times \tau_0 \div \tau_1$.

Let l denote the whole length of the chimney, and of the flue leading to it, in feet;

m , its "hydraulic mean depth," that is, its area divided by its perimeter (see Article 99); which, for a square or round flue and chimney, is one quarter of the diameter;

f , a co-efficient of friction, whose value for currents of gas moving over sooty surfaces is estimated by Peclet at 0.012;

G , a factor of resistance for the passage of the air through the grate and the layer of fuel above it, whose value, according to the experiments of Peclet on furnaces burning from 20 to 24 lbs. of coal per square foot of grate, is 12.

Then, according to a formula of Peclet, confirmed by practical experience, the "head" required to produce the draught in question is given by the equation

$$h = \frac{u^2}{2g} \left(1 + G + \frac{fl}{m} \right); \dots \dots \dots (4.)$$

which, with the values assigned by Peclet to the constants, becomes

$$h = \frac{u^2}{2g} \left(13 + \frac{0.012l}{m} \right). \dots \dots \dots (4 A.)$$

It appears that in using this formula, a conical or pyramidal chimney may, without sensible error, be treated as if it were cylindrical or prismatic, with an uniform sectional area equal to that of the opening at the top.

The same formula enables the velocity u to be computed when the head h is given; and then, by means of the equation

$$w = \frac{u A \tau_0}{V_0 \tau_1}, \dots \dots \dots (5.)$$

the weight of fuel which the furnace is capable of completely burning per hour can be computed.

The head h is expressed in feet in height of a column of the hot gas in the chimney. It may be converted into an equivalent pressure in pounds on the square foot, by multiplying as follows by the density of that gas as given by equation 3:—

$$p = h D = h \frac{\tau_0}{\tau_1} \left(0.0807 + \frac{1}{V_0} \right); \dots \dots \dots (6.)$$

and this again may be converted into any other convenient unit of pressure, by multiplying by a suitable factor, such as those in Article 107, page 110.

An unit of head very commonly employed is an *inch of water*; siphon water gauges, graduated into inches and decimals, being used to indicate the difference of pressure within and without a flue. For this unit the multiplier is $\frac{1}{5 \cdot 204} = 0 \cdot 192$; that is to say,

$$\text{Head in inches of water} = 0 \cdot 192 p = 0 \cdot 192 h \frac{\tau_0}{\tau_1} \left(0 \cdot 0807 + \frac{1}{V_0} \right). \quad (7.)$$

The head may be produced in three ways—

- I. By the draught of a chimney.
- II. By a blast pipe.
- III. By a fan or other blowing machine.

I. The head produced by the draught of a chimney is equivalent to the excess of the weight of a vertical column of cool air outside the chimney, and of the same height, above that of a vertical column of equal base, of the hot gas within the chimney; and when expressed in *feet of hot gas*, it is found by computing the weight of a column of the cool external air as high as the top of the chimney is above the grate and one foot square in the base, dividing by the weight of a cubic foot of the hot gas for the height of an equivalent column of hot gas, and subtracting the former height from the latter.

Thus, let H denote the height of the chimney, and τ_2 the *absolute* temperature of the external air ($= T_2 + 461 \cdot 2$), then

$$h = \frac{H \cdot \frac{\tau_0}{\tau_2} (0 \cdot 0807)}{\frac{\tau_0}{\tau_1} \left(0 \cdot 0807 + \frac{1}{V_0} \right)} - H = H \left(0 \cdot 96 \frac{\tau_1}{\tau_2} - 1 \right); \dots (8.)$$

$$H = h \div \left(0 \cdot 96 \frac{\tau_1}{\tau_2} - 1 \right) \dots \dots \dots (9.)$$

Equation 9 serves to calculate the height of the chimney required in order to produce a given draught.

For a given external temperature, there is a certain temperature within the chimney which produces the most effective draught; that is, the maximum *weight* of hot gas discharged per second. That temperature is found as follows:—

The velocity of the gas in the chimney is proportional to \sqrt{h} ; and therefore to $\sqrt{(0 \cdot 96 \tau_1 - \tau_2)}$.

The density of that gas is proportional to $\frac{1}{\tau_1}$.

The weight discharged per second is proportional to velocity \times density, and, therefore, to $\frac{\sqrt{(0.96 \tau_1 - \tau_2)}}{\tau_1}$; which expression becomes a maximum when

$$\tau_1 = \frac{2 \tau_2}{0.96} = 2\frac{1}{3} \tau_2; \dots\dots\dots(10.)$$

therefore, the *best chimney-draught takes place when the absolute temperature of the gas in the chimney is to that of the external air as 25 to 12.*

When this condition is fulfilled, we have evidently

$$h = H; \dots\dots\dots(11.)$$

that is, *the head for the best chimney-draught, expressed in hot gas, is equal to the height of the chimney; and it is also obvious, that the density of the hot gas is one-half of that of the external air.*

Suppose, for example, that the temperature of the external air on the ordinary scale is..... 50° Fahr.
 then its absolute temperature is..... 511.2
 the absolute temperature within the chimney, to give
 the best draught, is $2\frac{1}{3} \times 511.2 = 1065.0$
 corresponding on the ordinary scale to..... 603.8

being a little below the temperature of melting lead. It may be laid down as a practical rule, that *to insure the best possible draught through a given chimney, the temperature of the hot gas in the chimney should be nearly, but not quite, sufficient to melt lead.*

As the proper allowance of air for a chimney-draught is 24 lbs. to each lb. of fuel, the volume, at that temperature, of the hot gas discharged by the chimney, is about 650 cubic feet per lb. of fuel, or 26 cubic feet per lb. of the hot gas itself.

When the temperature in a chimney is found to be above this limit, it is to be reduced, not by admitting cold air to dilute the hot gas, but by employing the surplus heat for some useful purpose, such as heating or evaporating water.

So long as the draught in a chimney is sufficient to burn the requisite quantity of fuel in the furnace, the temperature in the chimney may often be reduced with advantage considerably *below* that corresponding to the most effective draught, provided the heat abstracted from the hot gas is usefully employed; but it is never advantageous to raise the temperature in the chimney *above* that limit.

II. The head produced by a *blast pipe* is equivalent to that part

of the atmospheric pressure which is balanced by means of the impact of the jet of steam against the column of gas in the chimney. Its amount and effect will be considered in a subsequent chapter.

III. The work which a fan or other blowing machine must perform in a given time in blowing air into a furnace so as to produce a given head, is found by multiplying the *pressure* equivalent to that head, in pounds on the square foot (p , equation 6), into the number of cubic feet of air blown in, taken at the temperature at which it quits the blowing machine. Let τ_3 be that temperature on the absolute scale (being equal to, or higher than τ_2 , that of the external air, as the case may be); then the *net* or *useful* work of the blowing machine per second is

$$p \cdot \frac{w V_0 \tau_3}{\tau_0} = w V_0 \cdot \frac{\tau_3}{\tau_1} h \left(0.0807 + \frac{1}{V_0} \right) \dots \dots (12.)$$

The *gross* power or energy required to drive a blowing fan is greater than the useful work in a proportion which varies much in different machines, and is very uncertain. In some recent experiments, as nearly as it could be ascertained, the indicated power exerted by two steam engines driving fans through long trains of shafting, pulleys, and belts, appeared in each case to be about *double* of the useful effect.

234. Available Heat of Combustion—Efficiency of Furnace.—

The *available* heat of combustion of one pound of a given sort of fuel, is that part of the total heat of combustion which is communicated to the body to heat which the fuel is burned; for example, to the water in a steam boiler; and the *efficiency* of a given furnace, for a given sort of fuel, is the proportion which the available heat bears to the total heat, when the given sort of fuel is burned in the given furnace.

The word "furnace" is here to be understood to comprehend, not merely the chamber in which the combustion takes place, but the whole apparatus for burning the fuel and transferring heat to the body to be heated, including ash pit, air holes, flame chamber, flues, tubes, and heating surface of every kind, and chimney.

The same kind of furnace may be more efficient for one sort of fuel than for another; and it may also be more or less efficient for the same sort of fuel, according to the way in which the combustion is managed.

The available heat falls short of the total heat from several causes, of which the principal are the following:—

I. *Waste of Unburnt Fuel in the Solid State.*—This generally arises from brittleness of the fuel, combined with want of care in the stoker; by which causes the fuel is made to fall into small pieces, which escape between the grate bars into the ash pit.

Many of the most valuable kinds of coal, such as the dry steam coals, are brittle. The waste of such coals in the solid state is to be prevented by the following means:—(1.) They are to be thrown evenly and uniformly over the fire with the shovel, so that there shall be no occasion to disturb them after they are first thrown in. (2.) The fire is not to be stirred from above; and the grate bars are to be cleared when required, by a hook or slice from below. (3.) The ashes are to be riddled from time to time, and the small coal or cinders contained amongst them thrown upon the fires.

It is impossible to estimate the greatest amount of this kind of waste which may arise from careless firing; but the amount which is unavoidable with good firing has in some cases been ascertained by experiment, and found to range from nothing, up to about 2½ per cent.

II. *The Waste of Unburnt Fuel in the Gaseous and Smoky States*, and the means of preventing that waste, by a sufficient supply and proper distribution of air, have been stated in the preceding Articles.

The greatest probable amount of that waste, when the absence of any provision for introducing air to burn the inflammable gases is combined with bad firing, may be estimated by taking the proportion in which the total heat of combustion of the coke or fixed carbon contained in one pound of the coal is less than the total heat of combustion of all the constituents of one pound of the coal.

When the firing is conducted with care, but the supply of air insufficient, the waste may be estimated by treating the hydrogen as ineffective; that is, by taking the proportion in which the heat due to the *whole* of the carbon in the coal is less than the heat due to the carbon and to the hydrogen in excess of that required to form water with the oxygen in the coal. This method of calculation proceeds on the supposition, that the whole of the hydrocarbons are decomposed into carbon and hydrogen by the heat, that the carbon is completely burnt, and that the hydrogen escapes unburnt. That supposition appears to represent with an approach to accuracy the state of things in good ordinary steam boiler furnaces which have no special provision for distributing air amongst the inflammable gases; for the result of experience with such furnaces is, that the relative values of coals consumed in them are nearly proportional to the quantities of carbon contained in those coals.

It appears, then, that there are *two degrees* of waste from imperfect combustion of the gas and smoke from *one pound* of bituminous coal, which, as reduced to *equivalent weights of carbon*, may be expressed as follows:—

	Waste reduced to carbon.
(1.) Insufficient air, but good firing, the surplus hydrogen wasted,.....	4.28 $\left(H - \frac{O}{8} \right)$.
(2.) Very insufficient air, and bad firing; all the hydrocarbons wasted. If the hydrogen and carbon in these are combined in the same proportion as in marsh gas ($H_2 C$); then for every lb. of hydrogen wasted, 3 lbs. of carbon are wasted also; giving as the total waste reduced to carbon,.....	7.28 $\left(H - \frac{O}{8} \right)$;
If the hydrogen and carbon are combined in the same proportion as in olefiant gas ($H_2 C_2$), then for every lb. of hydrogen wasted, 6 lbs. of carbon are wasted also; giving as the total waste reduced to carbon,.....	10.28 $\left(H - \frac{O}{8} \right)$;
and for intermediate proportions, intermediate quantities are wasted.	

III. *Waste by External Radiation and Conduction.*—The waste by direct radiation from burning coal through an open fire door may be approximately estimated according to the principles of Article 228, by assuming, in the first place, the heat directly radiated from the fuel to be one-half of the total heat of combustion; next, conceiving the surface of the burning mass to be divided into several small equal parts, from each of which an equal share of the heat radiates; then, finding what fraction of the surface of a sphere described about one of those parts is subtended by the opening through which the radiation takes place, and multiplying the share of heat radiated from the part of the fuel in question by that fraction; and, lastly, adding together the products so found for the several parts of the burning fuel. The loss by conduction through the solid boundaries of the furnace might be estimated from their area, their material, their thickness, their thermal resistance, and the difference of the temperatures within and without the furnace, by the principles of Article 219.

In well planned and well constructed furnaces, however, those losses of heat should be practically inappreciable; and the general nature of the means of making them so has been stated in Article 228.

IV. *Waste or Loss of Heat in the Hot Gas which Escapes by the Chimney.*—Considering that the temperature of the fire, in a furnace with a draught produced by a chimney, and supplied with 24 lbs. of air per lb. of fuel, is about 2400° Fahr. above the temperature of the external air, and that the temperature of the hot gas in

the chimney, in order to produce the best possible draught, should be about 600° above the temperature of the external air, it appears, that under no circumstances can it be necessary to expend more than *one-fourth* of the total heat of combustion for the purpose of producing a draught by means of a chimney. By making the chimney of large enough dimensions as compared with the grate, a much less expenditure of heat than this may be made to produce a draught sufficient for the rate of combustion in the furnace.

When the draught is produced by means of a blast pipe, or of a blowing machine, no elevation of temperature above that of the external air is *necessary* in the chimney; therefore, furnaces in which the draught is so produced are capable of greater economy than those in which the draught is produced by means of a chimney.

It appears further, as has already been stated, that with a forced draught there is less air required for dilution, consequently a higher temperature of the fire, consequently a more rapid conduction of heat through the heating surface, consequently a better economy of heat than there is with a chimney-draught.

The proportion of the whole heat which is lost with the gas discharged by the chimney depends mainly on the *efficiency of the heating surface*, which has already been considered in Article 221.

Referring to equation 13, in case 2 of that Article, let E denote the theoretical evaporative power, and E' the available evaporative power, of one lb. of a given sort of fuel, in a boiler furnace in which the area of heating surface is S . Then

$$\frac{E'}{E} = B \cdot \frac{S}{S + \frac{a c^2 W^2}{H}} \dots \dots \dots (1.)$$

Where B is a fractional multiplier, to allow for miscellaneous losses of heat, whose value is to be found by experiment.

Now $c^2 W^2$ is proportional nearly to $F^2 V_0^2$, where F is the number of lbs. of fuel burnt in the furnace in a given time, and V_0 , as in a former Article, the volume at 32° of the air supplied per lb. of fuel. Also, $H \propto F \times$ a constant.

Hence it may be expected, that the efficiency of a furnace will be expressed to an approximate degree of accuracy, by the following formula:—

$$\frac{E'}{E} = \frac{BS}{S + AF} \dots \dots \dots (2.)$$

in which A is a constant, which is to be found empirically, and is

* This formula, and most of the examples which follow it, were first published in a paper read to the Institution of Engineers in Scotland, on the 20th of April, 1859.

probably proportional approximately to the *square* of the quantity of air supplied per lb. of fuel.

It is customary and convenient to refer various dimensions and quantities relating to a furnace to the *square foot of grate*; therefore S may be taken to represent the number of square feet of heating surface, and F the number of lbs. of fuel burnt per hour, *per square foot of grate*.

The following are the values of the constants B and A which have been found to agree best with experiment, so far as the practical performance of boilers has hitherto been compared with the formula:—

Boiler Class I. The convection taking place in the best manner (see Article 220), either by introducing the water at the coolest part of the boiler, and making it travel gradually to the hottest (as in Lord Dundonald's boiler), or by heating the feed-water in a set of tubes in the uptake; the draught produced by a chimney,.....	B	A
	1	0·5
Boiler Class II. Ordinary convection, and chimney draught,	$\frac{11}{12}$	0·5
Boiler Class III. Best convection, and forced draught,	1	0·3
Boiler Class IV. Ordinary convection, and forced draught,.....	$\frac{11}{12}$	0·3

When there is a feed-water heater, its surface should be *included* in computing S; and the surface of tubes surrounded by water is to be measured outside.

The formula is of course not intended to supersede experiments and practical trials, nor to give results as accurate and satisfactory as such experiments and trials, but to furnish a convenient means of estimating approximately the evaporative power of fuel in proposed boilers, and the comparative efficiency of different boilers.

The formula is framed on the supposition that the admission of air and the management of the fire are such, that no appreciable loss occurs, either from imperfect combustion or from excess of air, the construction and proportions of the furnace, and the mode of using it, being the best possible for each kind of coal.

If desired, the effect of imperfect combustion and bad firing may be estimated in the manner described in Division III. of this Article, and that of an excess of air by increasing A in proportion to the square of the quantity of air supplied.

The following are examples of efficiency calculated by means of the formula:—

$\frac{S}{F}$	$\frac{E'}{E}$			
	For class of boiler			
	I.	II.	III.	IV.
0.1	0.16	0.15	0.25	0.22
0.25	0.33	0.31	0.45	0.43
0.5	0.50	0.46	0.62	0.59
0.75	0.60	0.55	0.71	0.68
1.0	0.66	0.61	0.77	0.73
1.25	0.71	0.65	0.81	0.77
1.5	0.75	0.69	0.83	0.79
2.0	0.80	0.73	0.87	0.83
2.5	0.83	0.76	0.89	0.85
3.0	0.86	0.79	0.91	0.86
6.0	0.92	0.84	0.95	0.90
9.0	0.95	0.87	0.97	0.92

The following are particular cases:—

I. North country coal—

$$E = 15.5; S = \frac{1075}{22} = 48; F = 25;$$

boiler with feed-water heater, and chimney-draught; or Class I.—

$$E' = 15.5 \times 0.8 = 12.4.$$

This agrees closely with the results of the experiments at Newcastle on fresh coal, both by the Newcastle committee, and by the Admiralty reporters.

II. Same coal, same boiler without heater—

$$S = \frac{755}{22} = 35; F = 27.$$

Boiler Class II.—

$$E' = 15.5 \times 0.66 = 10.23.$$

This nearly agrees with an experiment made by the Admiralty reporters at Newcastle, in which the result was 10.54.

III. Same coal—

$$S = 25; F = 25; \text{ no heater.}$$

Boiler Class II.—

$$E' = 15.5 \times 0.61 = 9.5.$$

This applies to several ordinary marine boilers.

IV. Locomotive boiler, Class IV.—

$$\text{Coke, } E = \text{say } 14.1; S = 60; F = 56.$$

$$E' = 14.1 \times .74 = 10.43 \text{ from } 212^\circ;$$

Equivalent evaporation from 62° at 329° ,

$$\frac{10.43}{1.2} = 8.69.$$

The above proportions of S and F are computed from a formula of Mr. D. K. Clark, as being suitable to insure an evaporative power of 9, from 62° at 329° . The difference is only $\frac{1}{16}$.

V. Locomotive boiler, Class IV. (mean of Mr. D. K. Clark's experiments, Nos. 38, 39, 40, 41, 42)—

$$E = \text{say } 14.1; S = 83; F = 65\frac{1}{2};$$

$$E' = 14.1 \times .77 = 10.86 \text{ from } 212^\circ;$$

Equivalent evaporation from 62° at 329° ,

$$\frac{10.86}{1.2} = 9.05$$

Mean result of experiments,8.72

Difference,0.33

VI. Locomotive boiler, Class IV. (mean of Mr. D. K. Clark's experiments, Nos. 48, 49, 50, 51, 53)—

$$E = \text{say } 14.1; S = 66.4; F = 56.2;$$

$$E' = 14.1 \times .76 = 10.72 \text{ from } 212^\circ;$$

Equivalent evaporation from 62° at 329° ,

$$\frac{10.72}{1.2} = 8.93$$

Mean result of experiments,8.75

Difference,0.18

VII. Locomotive boiler, Class IV. (Mr. D. K. Clark's experiment, No. 55; mean of 10 trips)—

$$E = \text{say } 14.1; S = 57; F = 44;$$

$$E' = 14.1 \times .77 = 10.86 \text{ from } 212^\circ.$$

Equivalent evaporation from 62° at 329°,

$$\frac{10.86}{1.2} = 9.05$$

Result of experiments,.....9.00

Difference,.....0.05

VIII. Locomotive boiler, Class IV. (Mr. D. K. Clark's experiment, No. 61, mean of 8 trips)—

$$E = \text{say } 14.1; S = 60; F = 87;$$

$$E' = 14.1 \times .66 = 9.3 \text{ from } 212^\circ;$$

Equivalent evaporation from 62° at 329°,

$$\frac{9.3}{1.2} = 7.75$$

Result of experiment,.....7.2

Difference,.....0.55

The only principle followed in selecting experiments from Mr. Clark's table is that of giving the preference to those cases in which a mean can be obtained from the results of a large number of experiments under similar or nearly similar circumstances.

The general conclusion to be drawn from the preceding comparisons is, that the formula agrees closely with the results of experiment up to a rate of consumption of about 60 lbs. per square foot of grate; and that above that rate of consumption, although there is still an approximate agreement, the results of experiment fall somewhat short of those given by the formula. It is probable, however, that for those high rates of consumption, the combustion is not so complete as at lower rates, and that some heat is consequently wasted.

Example IX.—Boiler Class II.—

$$E = \text{about } 15\frac{1}{2}; S = 60, \text{ nearly}; F = 6.4;$$

$$E' = 15\frac{1}{2} \times .87 = 13.48$$

Result of experiment,.....13.56

Difference,.....0.08

The above is the result of an experiment of the Author's.

Example X.—The Earl of Dundonald's boiler. This boiler is considered as belonging to Class I., because of the feed-water being introduced at the part where the gas from the furnace is coolest—

$E = \text{about } 16?$ (for hand-picked Llangennech coal);

$$S = 3.35; F = 10.17;$$

$$E' = 16 \times 0.87 = 13.92$$

Mean result of two experiments with
 the feed-water at 50° , $12.14 \times \text{factor}$ } 14.20
 of evaporation 1.17,.....)

Difference,..... 0.28

CHAPTER III.

PRINCIPLES OF THERMODYNAMICS.

SECTION I.—*Of the Two Laws of Thermodynamics.*

235. **Thermodynamics Defined.**—It is a matter of ordinary observation, that heat, by expanding bodies, is a source of mechanical energy; and conversely, that mechanical energy, being expended either in compressing bodies, or in friction, is a source of heat. Such phenomena have already been incidentally referred to, in Article 13, under the head of Friction; in Article 195, where the relations between heat and mechanical energy are mentioned; in Article 196, under the head of the Properties of the Condition of Heat, numbered IV., V., and VI.; and in Articles 211 to 216, under the head of Latent Heat, which disappears in producing mechanical changes, and can be reproduced by reversing those changes.

The reduction of the laws according to which such phenomena take place, to a physical theory, or connected system of principles, constitutes what is called the SCIENCE OF THERMODYNAMICS.

236. **First Law of Thermodynamics.**—*Heat and mechanical energy are mutually convertible; and heat requires for its production, and produces by its disappearance, mechanical energy in the proportion of 772 foot-pounds for each British unit of heat:* the said unit being the amount of heat required to raise the temperature of one pound of liquid water by one degree of Fahrenheit, near the temperature of the maximum density of water. This law may be considered as a particular case of the application of two more general laws, viz. :—1. All forms of energy are convertible. 2. The total energy of any substance or system cannot be altered by the mutual actions of its parts.

The quantity above stated, 772 foot-pounds for each British thermal unit, is commonly called "*Joule's equivalent*," and denoted by the symbol J, in honour of Mr. Joule, who was the first to determine its value *exactly*. His first approximate determination of this quantity was published in 1843, a little after that of Mayer; his best set of experiments, from which the accepted value 772 is deduced, may be consulted in the *Philosophical Transactions* for 1850.

In these experiments, the heat produced by mutual friction of the particles of a *liquid* was compared with the mechanical energy expended in producing that friction. The advantage of this kind of experiment is, that the liquid, and all the parts of the apparatus, are left exactly in the same condition at the end of the experiment as they were at the beginning; so that it is certain, that no permanent effect whatsoever has been produced by the mechanical energy expended, except a certain quantity of heat, which is accurately measured; and, therefore, that the heat so produced is the exact equivalent of the mechanical energy expended.

In all other cases in which heat is produced by the expenditure of mechanical energy, or mechanical energy by the expenditure of heat, some other change is produced besides that which is principally considered; and this prevents the heat and the mechanical energy from being exactly equivalent.

The following are the values of Joule's equivalent for different thermometric scales, and in French and British units:—

J.	
One British thermal unit, or degree of Fahrenheit in a lb. of water,.....	} 772 foot-lbs.
One Centigrade degree in a lb. of water, 1389·6 (or very nearly 1390).	} „
One French thermal unit, or Centigrade degree in a kilogramme of water,.....	} 423·55 kilogrammètres.

The production of heat by friction is distinguished from its production by other mechanical means, such as the compression of gases, in being *irreversible*; that is to say, it is impossible to make heat produce mechanical energy by any such means as *reversing the process of friction*.

237. **Dynamical expression of Quantities of Heat.**—All quantities of heat, such as the *specific heat* of any substance, or the *latent heat* corresponding to any physical effect, or any other of the quantities of heat treated of in Chapters I. and II., may be expressed *dynamically*, that is, in units of work, by multiplying their values in ordinary units of heat by Joule's equivalent. Several examples of this mode of expressing quantities of heat, which is by far the most convenient in treating of thermodynamical questions, are given in the tables at the end of this volume. The following are additional examples:—

	Foot-lbs.
Latent heat of evaporation of 1 lb. of water, from and at 212°,.....	} 745,812
Total heat of combustion of 1 lb. of carbon,.....	11,194,000

238. **Graphic Representation of the First Law.**—In fig. 91, let abscissæ, measured along, or parallel to, the axis $O X$, represent the volumes successively assumed by a given mass of an elastic substance, by whose alternate expansion and contraction heat is made to produce mechanical energy; $O V_A$ and $O V_B$ being the least and greatest volumes which the substance is made to assume, and $O V$ any intermediate volume. For brevity's sake, these quantities will be denoted by v_a , v_b , and v , respectively. Then $v_b - v_a$ may represent the space traversed by the piston of an engine during a single stroke.

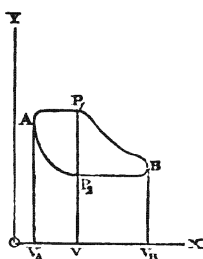

Fig. 91.

Let ordinates, measured parallel to the axis $O Y$, and at right angles to $O X$, denote the expansive pressures successively exerted by the substance at the volumes denoted by the abscissæ. During the increase of volume from v_a to v_b , the pressure, in order that motive power may be produced, must be, on the whole, greater than during the diminution of volume from v_b to v_a ; so that, for instance, the ordinates $V P_1$ and $V P_2$, or the symbols p_1 and p_2 , may represent the pressures corresponding to a given volume v , during the expansion and contraction of the substance respectively.

Then, as in Article 43, and fig. 17, the area of the curvilinear figure, or *indicator-diagram*, $A P_1 B P_2 A$, will represent the energy exerted by the elastic substance on the piston during a complete stroke, or cycle of changes of volume of the elastic substance. The algebraical expression for that area is

$$\int_{v_a}^{v_b} (p_1 - p_2) dv;$$

and this, in virtue of the first law of thermodynamics, represents also, in units of work, the *mechanical equivalent of the heat which disappears* during a complete forward and back stroke of the piston; that is to say, if h_1 represents the quantity of heat, in common thermal units, *received* by the elastic substance during one part of the process (such, for example, as the heat communicated to a certain weight of water in a boiler in order to produce steam), and h_2 the quantity of heat *rejected* by the same substance during another part of the process (such, for example, as the heat abstracted from the same quantity of water in the condenser of a condensing engine, or by the air, in a non-condensing engine); and if H_1 and H_2 are the same quantities of heat expressed in foot-pounds, then, by the first law,

$$J(h_1 - h_2) = H_1 - H_2 = \int (p_1 - p_2) dv \dots \dots \dots (1.)$$

239. **Thermal Lines.**—A line drawn on a diagram of energy, such that its ordinates represent the pressures of a substance corresponding to various volumes, while the absolute temperature is maintained at a constant value, denoted, for example, by τ , may be called the *isothermal line of τ* for the given substance (see fig. 92). Suppose, for instance, that the co-ordinates of the point A, v_a and p_a , represent respectively a volume and a pressure of a given substance, at which the absolute temperature is τ ; and the co-ordinates of the point B, viz, v_b and p_b , another volume and pressure at which the absolute temperature is the same; then are the points A and B situated on the same isothermal line T T.

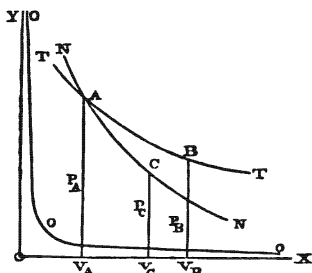

Fig. 92.

a *curve of no transmission, or adiabatic curve.*

It is to be understood that, during the process last described, the mechanical energy exerted during the expansion, and which is represented by the area A C V_C V_A, is entirely communicated to an external body, such as a piston; for if any part of it were expended in agitating the particles of the expanding substance, a portion of heat would be reproduced by friction.

If o o o be a curve whose ordinates represent the pressures corresponding to various volumes when the substance is absolutely destitute of heat, then this curve, which may be called the *line of absolute cold*, is at once an isothermal curve and an adiabatic curve.

So far as we yet know, the line of absolute cold, for all substances for which it has been ascertained, is an asymptote to all the other isothermal curves and curves of no transmission, which approach it and each other indefinitely as the volume of the substance increases without limit; and it coincides sensibly with the straight line O X; that is to say, a substance wholly destitute of heat exerts no expansive pressure.

The following property of adiabatic curves, in connection with the first law of thermodynamics, is the foundation of many useful propositions. (It was first demonstrated in the *Philosophical Transactions* for 1854.)

THEOREM. *The mechanical equivalent of the heat absorbed or given out by a substance in passing from one given state as to pressure and volume to another given state, through a series of states represented by the co-ordinates of a given curve on a diagram of energy, is represented by the area included between the given curve and two curves of no transmission of heat drawn from its extremities, and indefinitely prolonged in the direction representing increase of volume.*

(Demonstration) (see fig. 93). Let the co-ordinates of any two points, A and B, represent respectively the volumes and pressures of the substance in any two conditions; and let a curve of any figure, A C B, represent by the co-ordinates of its points, an arbitrary succession of volumes and pressures through which the substance is made to pass, in changing from the condition A to the condition

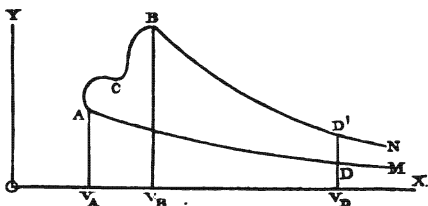

Fig. 93.

B. From the points A and B respectively, let two adiabatic curves A M, B N, extend indefinitely towards X; then the area referred to in the enunciation is that contained between the given arbitrary curve A C B and the two indefinitely prolonged adiabatic curves; areas above the curve A M being considered as representing heat absorbed by the substance, and those below, heat given out.

To fix the ideas, let us in the first place suppose the area M A C B N to be situated above A M. After the substance has reached the state B, let it be expanded according to the adiabatic curve B N, until its volume and pressure are represented by the co-ordinates of the point D'. Next, let the volume v_D be maintained constant, while heat is abstracted until the pressure falls so as to be represented by the ordinate of the point D, situated on the curve of no transmission A M. Finally, let the substance be compressed, according to this curve of no transmission, until it recovers its primitive condition A. Then the area A C B D' D A, which represents the whole energy exerted by the substance on a piston during one cycle of operations, represents also the heat which disappears; that is, the difference between the heat absorbed by the

substance during the change from A to B, and the heat emitted during the change from D' to D; for if this were not so, the cycle of operations would alter the amount of energy in the universe, which is impossible.

The further the ordinate $V_D D D'$ is removed in the direction of X, the smaller does the heat emitted during the change from D' to D become; and consequently, the more nearly does the area A C B D' D A approximate to the equivalent of the heat absorbed during the change from A to B; to which, therefore, the area of the indefinitely prolonged diagram M A C B N is exactly equal.—Q.E.D.

It is easy to see how a similar demonstration could have been applied, *mutatis mutandis*, had the area lain below the curve A M. It is evident also, that when this area lies, part above and part below the line A M, the difference between those two parts represents the difference between the heat absorbed and the heat emitted during different parts of the operation.

COROLLARY.—*The difference between the whole heat absorbed, and the whole expansive energy exerted, during the operation represented by any curve, such as A C B, on a diagram of energy, depends on the initial and final conditions of the substance alone, and not on the intermediate process.*

(Demonstration.) In fig. 93, draw the ordinates $A V_A$, $B V_B$, parallel to O Y. Then the area $V_A A C B V_B$ represents the energy exerted in a piston during the operation A C B; and it is evident that the difference between this area and the indefinitely prolonged area M A C B N, which represents the heat received by the substance, depends simply on the positions of the points A and B, which denote the initial and final conditions of the substance as to volume and pressure, and not on the form of the curve A C B, which represents the intermediate process.—Q.E.D.

To express this result symbolically, it is to be considered, that the excess of the heat or actual energy *received* by the substance above the expansive power or potential energy *given out* and exerted on an external body, such as a piston, in passing from the condition A to the condition B, is equal to the whole energy *stored up* in the substance during this operation, which consists of two parts, viz.—

Actual energy; being the increase of the actual or sensible heat of the substance in passing from the condition A to the condition B, which may be represented by this expression,

$$\Delta \cdot Q = Q_B - Q_A.$$

Potential energy; being the power which is stored up in producing changes of molecular arrangement during this process; and which,

it appears from the theorem just proved, must be represented, like the actual energy, by the difference between a function of the volume and pressure corresponding to A, and the analogous function of the volume and pressure corresponding to B; that is to say, by an expression of the form

$$\Delta S = S_B - S_A \dots \dots \dots (1.)$$

Let $H_{A, B} = \text{area M A C B N}$

represent the heat received by the substance during the operation A C B, and

$$\int_{v_a}^{v_b} p \, dv = \text{area V}_A \text{ A C B V}_B$$

the power or potential energy exerted on a piston.

Then the theorem of this Article is expressed as follows:—

$$H_{A, B} - \int_{v_a}^{v_b} p \, dv = Q_B - Q_A + S_B - S_A = \Delta Q + \Delta S \dots (2.)$$

being a form of the general equation of the expansive action of heat, in which the *potential of molecular action*, S, remains to be determined.

240. **Total Actual Heat.**—Let a substance, by the expenditure of energy in friction, be brought from a condition of total privation of heat to any particular condition as to heat. Then, if from the total energy so expended, there is subtracted—first, the mechanical work performed by the action of the substance on external bodies, through changes of its volume and figure, during such heating; secondly, the mechanical work due to mutual actions between the particles of the substance itself during such heating; the remainder will represent the energy which is employed in *making the substance hot*, and which might be made to reappear as ordinary mechanical energy, if it were possible to reduce the substance to a state of total privation of heat. This remainder is the quantity called the *total actual heat* of the substance; being the total energy, or capacity for performing work, which the substance possesses *in virtue of being hot*. It is not directly measurable; but its value may be computed from known quantities, by means to be afterwards explained. When a homogeneous substance is uniformly hot, every particle of it is equally hot; and every particle is hot in virtue of a condition of its own, and independently of forces exerted between it and other particles. These are facts known by experience; and they lead to the following consequence:—that when the total actual heat of a homogeneous and uniformly hot substance is

considered as a quantity made up of any number of equal parts, all those equal parts are similarly circumstanced; and hence follows—

241. **The Second Law of Thermodynamics.**—*If the total actual heat of a homogeneous and uniformly hot substance be conceived to be divided into any number of equal parts, the effects of those parts in causing work to be performed are equal.*—This law may be considered as a particular case of a general law applicable to every kind of *actual energy*; that is, capacity for performing work, constituted by a certain condition of each particle of a substance, how small soever, independently of the presence of other particles (such as the energy of motion). The symbolical expression of the second law of thermodynamics is as follows:—Let unity of weight of a homogeneous substance, possessing the actual heat Q , undergo any indefinitely small change, so as to perform the indefinitely small amount of work dU . It is required to find how much of this work is performed by the disappearance of heat. Conceive Q to be divided into an indefinite number of indefinitely small equal parts, each of which is δQ . Each of those parts will cause to be performed the quantity of work represented by

$$\delta Q \cdot \frac{d}{dQ} dU,$$

consequently the quantity of work performed by the disappearance of heat will be

$$Q \cdot \frac{d}{dQ} dU, \dots \dots \dots (1.)$$

which quantity is known when Q , and the law of variation of dU with Q , are known.

242. **Absolute Temperature—Specific Heat, Real and Apparent.**—*Temperature* is a function depending on the tendency of bodies to communicate the condition of heat to each other. Two bodies are at *equal temperatures*, when the tendencies of each to make the other hotter are equal. All substances absolutely devoid of heat are at the same temperature. Let this be called the *absolute zero of heat*; and let the scale of temperature be so graduated, that for a given homogeneous substance, each degree shall correspond to an equal increment of actual heat.* This mode of graduation neces-

* The mode of graduation above described leads to a *dynamical* scale of absolute temperatures. In Article 201, a scale of absolute temperatures is described, founded upon the elasticity of a perfect gas. It was anticipated some years ago, by certain theoretical and hypothetical investigations, that the scale of the perfect gas thermometer would be found to agree with the dynamical absolute thermometric scale, as to the length of its degrees; and also that the zeros of those scales would be found to be near each other, if not coincident. Throughout many of the papers referred to, the formulæ were so framed as to contain unknown terms, suited to provide for the possi-

sarily leads to the same scale of temperature for all substances. For if two substances A and B be at equal temperatures when they possess respectively two certain quantities of actual heat Q_A and Q_B , then if each of those quantities of actual heat be divided into the same number of equal parts n , the tendency of the substance A to communicate heat to B, arising from any one of the n th parts of Q_A , must, from the property of actual heat already mentioned, be equal to the tendency of B to communicate heat to A, arising from any one of the n th parts of Q_B ; from which it follows, that so long as the quantities of actual heat possessed by the two substances are in the ratio $Q_A : Q_B$, their temperatures are equal, independently of the *absolute amounts* of those quantities. The amount of actual heat, expressed in units of work, which corresponds, in a given substance, to *one degree of absolute temperature*, is the *real dynamical specific heat* of that substance, and is a constant quantity for all temperatures. The total quantity of mechanical energy required to raise the temperature of unity of weight of a substance by one degree, generally includes, besides the real specific heat, work performed in overcoming molecular forces and external pressures. This is the *apparent dynamical specific heat*; and may be constant or variable. Joule's equivalent is the apparent dynamical specific heat of liquid water at and near its maximum density; and it is probably equal sensibly to the real specific heat of that substance. The real specific heat of each substance is constant at all densities, so long as the substance retains the same condition, solid, liquid, or gaseous; but a change of real specific heat, sometimes considerable, often accompanies the change between any two of those conditions. From the mutual proportionality of actual heat and absolute temperature, there follows—

243. **The Second Law of Thermodynamics, expressed with reference to ABSOLUTE TEMPERATURE.** *If the absolute temperature of any uniformly hot substance be divided into any number of equal parts, the effects of those parts in causing work to be performed are equal.* This law is expressed algebraically as follows:—from the relation between absolute temperature (τ), and actual heat (Q), it follows that

$$\frac{d}{d\tau} = Q \frac{d}{dQ}$$

consequently the expression 1, for the work performed by the disappearance of heat, is transformed into

bility of a sensible difference between those zeros. But as, according to the latest and best experiments, no such appreciable difference has been found, the zero and scale of the perfect gas thermometer may be treated as sensibly, if not exactly, coincident with the dynamical absolute zero and absolute thermometric scale.

$$\tau \cdot \frac{d}{d\tau} dU \dots \dots \dots (1.)$$

This expression is applicable, not merely to homogeneous substances, but to heterogeneous aggregates.

When the expressions 1 of Articles 241 and 243 are negative, they represent heat which appears in consequence of the expenditure of mechanical work in altering the condition of a substance.

The first and second laws virtually comprise the whole theory of thermodynamics.

244. **Second Law, Represented Graphically.**—THEOREM. *In fig. 94, let $A_1 A_2 M, B_1 B_2 N$, be any two adiabatic curves, indefinitely extended in the direction of X , intersected in the points A_1, B_1, A_2, B_2 , by two isothermal curves, $Q_1 A_1 B_1 Q_1, Q_2 A_2 B_2 Q_2$, which correspond to two absolute temperatures, τ_1 and τ_2 , differing by the quantity $\tau_1 - \tau_2 = \Delta \tau$.*

Then the quadrilateral area, $A_1 B_1 B_2 A_2$, bears to the whole indefinitely prolonged area $M A_1 B_1 N$, the same proportion which the difference of temperature $\Delta \tau$ bears to the whole absolute temperature τ ; or

$$\frac{\text{area } A_1 B_1 B_2 A_2}{\text{area } M A_1 B_1 N} = \frac{\Delta \tau}{\tau} \dots \dots \dots (1.)$$

(Demonstration.) Draw the ordinates $A_1 V_{A1}, A_2 V_{A2}, B_1 V_{B1}, B_2 V_{B2}$. Suppose, in the first place, that $\Delta \tau$ is an aliquot part of τ , obtained by dividing the latter quantity by an integer n , which we are at liberty to increase without limit.

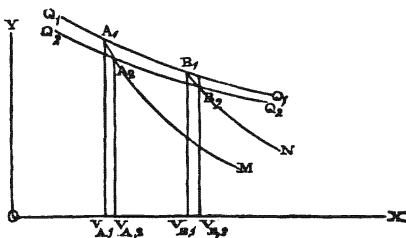

Fig. 94.

The entire indefinitely prolonged area $M A_1 B_1 N$ represents a quantity of heat which is converted into mechanical energy during the expansion of the substance from V_{A1} to

V_{B1} , in consequence of the continued presence of the absolute temperature τ_1 . *Mutatis mutandis*, a similar statement may be made respecting the area $M A_2 B_2 N$. (By increasing without limit the number n , and diminishing $\Delta \tau$, we may make the expansion from V_{A2} to V_{B2} as nearly as we please an identical phenomenon with the expansion from V_{A1} to V_{B1} .) The quadrilateral $A_1 B_1 B_2 A_2$ represents the diminution of conversion of heat to mechanical

energy, which results from the abstraction of any one whatsoever of the n equal parts $\Delta \tau$ into which the absolute temperature is supposed to be divided, and it therefore represents the effect, in conversion of heat to mechanical energy, of the presence of any one of those parts. And as all those parts $\Delta \tau$ are similar and similarly circumstanced, the effect of the presence of the whole absolute temperature τ_1 in causing conversion of heat to mechanical energy, will be simply the sum of the effects of all its parts, and will bear the same ratio to the effect of one of those parts which the whole absolute temperature bears to the part. Thus, by virtue of the general law enunciated below, the theorem is proved when $\Delta \tau$ is an aliquot part of τ_2 ; but $\Delta \tau$ is either an aliquot part, or a sum of aliquot parts, or may be indefinitely approximated to by a series of aliquot parts; so that the theorem is universally true.—Q. E. D.

A symbolical expression of this theorem is as follows:—When the absolute temperature τ_1 , at any given volume, is varied by the indefinitely small quantity $\delta \tau$, let the pressure vary by the indefinitely small quantity $\frac{dp}{d\tau} \delta \tau$; then the area of the quadrilateral $A_1 B_1 B_2 A_2$ will be represented by

$$\delta \tau \int_{v_a}^{v_b} \frac{dp}{d\tau} dv;$$

and consequently, that of the whole figure $M A_1 B_1 N$, or the LATENT HEAT OF EXPANSION from $V_{A,1}$ to $V_{B,1}$, at τ_1 , by

$$J h_1 = H_1 = \tau_1 \int_{v_a}^{v_b} \frac{dp}{d\tau} dv; \dots\dots\dots(2.)$$

a result substantially identical with that expressed in equation 1 of Article 243, when $p dv$ is put for dU .

The demonstration of this theorem is an example of a special application of the following

GENERAL LAW OF THE TRANSFORMATION OF ENERGY.

The effect of the presence in a substance, of a quantity of actual energy, in causing transformation of energy, is the sum of the effects of all its parts;

a law first enunciated in a paper read to the Philosophical Society of Glasgow on the 5th of January, 1853.

245. **Of Heat Potentials and Thermodynamic Functions.**—The second law of thermodynamics may also be expressed in the following form:—*The work performed by the disappearance of heat during*

any indefinitely small variation in the state of a substance, is expressed by the product of the absolute temperature into the variation of a certain function, which function is the rate of variation of the effective work performed with temperature; that is to say, make

$$\frac{dU}{d\tau} = F;$$

then the work performed by the disappearance of heat is

$$\tau dF \dots \dots \dots (1.)$$

This function F has been called the *heat potential* of the given substance for the kind of work under consideration.

Now let the substance both perform work and undergo a variation of absolute temperature $d\tau$, and let k denote its real dynamical specific heat. The whole heat which it must receive from an external source of heat, to produce those two effects simultaneously, is

$$J d h = d H = k d \tau + \tau d F = \tau d \phi; \dots \dots \dots (2.)$$

in which

$$\phi = k \cdot \text{hyp log } \tau + \frac{dU}{d\tau} \dots \dots \dots (3.)$$

ϕ is called the *thermodynamic function* of the substance for the kind of work in question; and in some papers, the *heat-factor*. The equation (2) is the **GENERAL EQUATION OF THERMODYNAMICS**, which we shall proceed, in the sequel, to apply, by determining the thermodynamic function for each particular case.

In determining that function, it is to be observed, that the function U , representing the work performed by the kind of change under contemplation, is first to be investigated as if the temperature were constant, and then the law of its variation with absolute temperature found.

The property of an *adiabatic curve* is expressed by $d \cdot H = 0$; from which it is evident, that for such a curve, $d\phi = 0$; that is to say, for a given adiabatic curve, the thermodynamic function has a constant value, proper to that curve.

In fig. 94, Article 244, the indefinitely extended area between the isothermal curve Q_1, Q_1 , and the two adiabatic curves $A_1 M, B_2 N$, is the product of the absolute temperature proper to the isothermal curve into the difference between the thermodynamic functions proper to the adiabatic curves.

SECTION 2.—*Expansive Action of Heat in Fluids.*

246. **General Laws as Applied to Fluids.** — In representing

graphically the general laws of thermodynamics, the illustrations already employed in Articles 238, 239, and 244, have been taken from the changes of pressure and volume of fluids as affected by heat. It is to be borne in mind, however, that the general laws are applicable to the relations which heat bears to the energy of all kinds of elastic forces, as well as to the simple expansive pressure exerted by fluids. In the expression for work performed against some external resistance,

$$dU = p \, dv,$$

dv , instead of an elementary increase of the *volume* of a substance, solid or fluid, may represent an elementary part of the motion which takes place amongst its particles, as it returns to its original figure after having been distorted, and p , the force with which it tends to recover its original figure; in which case, v may still be represented by the abscissa, and p by the ordinate of a diagram of energy, and $p \, dv$ by an elementary portion of the area of that diagram.

Inasmuch, however, as all known heat engines perform work by means of the changes of pressure and volume of fluids alone, it is unnecessary in this treatise to do more than to refer in general terms to the special application of the laws of thermodynamics to the elasticity of solids.

In the present section will be considered the more important of their special applications to the elasticity of fluids.

Let v denote the volume in cubic feet occupied by a given mass of any fluid, whether liquid or gaseous, enclosed in a vessel of variable capacity (such as a cylinder with a piston); p the pressure, or effort to expand, which the fluid exerts against the interior of the vessel, in pounds per square foot; then, as in Articles 6, 43, &c., will $p \, dv$ denote the external work in foot-pounds performed by the fluid during an indefinitely small expansion dv , and $\int p \, dv$ the external work performed during any finite expansion, the relation between p and v being fixed by the circumstances of the case. To find the thermodynamic function for the expansion of a fluid, the pressure p is to be expressed in the form of a function of the volume v , and absolute temperature τ , and the general value of the integral

$$U = \int p \, dv,$$

found on the supposition that τ is constant; then the thermodynamic function will be

$$\phi = k \cdot \text{hyp log } \tau + \int \frac{dp}{d\tau} \, dv \dots \dots \dots (1.)$$

The second term of this expression is represented graphically, as in fig. 94, by the limiting ratio of the area of the band $A_1 B_1 B_2 A_2$ to the difference between the absolute temperatures corresponding to the upper and lower edges of that band.

Applying the thermodynamic function to the determination, in foot-pounds, of the whole quantity of heat dH , which must be communicated to one pound of the fluid in order to produce simultaneously the indefinitely small variation of temperature $d\tau$, and the indefinitely small variation of volume dv , we find,

$$\begin{aligned} dH &= \tau \left(\frac{d\phi}{d\tau} d\tau + \frac{d\phi}{dv} dv \right) \\ &= \left(k + \tau \int_{\alpha}^v \frac{d^2 p}{d\tau^2} \cdot dv \right) d\tau + \tau \frac{dp}{d\tau} dv; \dots\dots\dots(2.) \end{aligned}$$

which is the general equation of the expansive action of heat in a fluid.

If this expression be analyzed, it is found to consist of the following parts:—

I. The variation of the actual heat of unity of weight of the fluid $k d\tau$.

II. The heat which disappears in producing work by mutual molecular actions depending on change of temperature and not on change of volume,

$$\tau \int_{\alpha}^v \frac{d^2 p}{d\tau^2} dv \cdot d\tau.$$

The lower limit of this integral is made to correspond to the state of indefinite rarefaction; that is, of perfect gas, in which those actions are null. Let $D = \frac{1}{v}$ be the density, or weight of unity of volume of the fluid; then we have, as a more convenient form of the integral,

$$\int_{\alpha}^v \frac{d^2 p}{d\tau^2} dv = - \int_0^D \frac{d^2 p}{d\tau^2} \cdot dD \dots\dots\dots(3.)$$

III. The latent heat of expansion,—that is, heat which disappears in performing work, partly by the forcible enlargement of the vessel containing the fluid, partly by mutual molecular actions depending on expansion, $\tau \frac{dp}{d\tau} dv$.

The heat, expressed in units of work, which must be communicated to unity of weight of a fluid to produce any given finite

changes of temperature and volume, is found by integrating the expression 2. Now that expression is not the exact differential of any function of the temperature and volume; consequently its integral does not depend solely on the initial and final condition of the fluid as to temperature and volume, but also upon the mode of intermediate variation of those quantities. The graphic representation of that integral is the indefinitely prolonged area M A C B N in fig. 93.

247. *Intrinsic Energy of a Fluid.*—Another mode of analyzing the expression 2 of Article 246 is as follows:—

I. The variation of actual heat, as before, $k d\tau$.

II. The *external work* performed, $p dv$, represented by an elementary vertical band of the area $V_A A C B V_B$, fig. 93.

III. The *internal work* performed in overcoming molecular forces, viz:—

$$\tau \int_{\alpha}^v \frac{d^2 p}{d\tau^2} dv \cdot d\tau + \left(\tau \frac{dp}{d\tau} - p \right) dv.$$

Now this last quantity is the exact differential of a function of the temperature and volume, viz:—

$$- \int_v^{\alpha} \left(\tau \frac{dp}{d\tau} - p \right) dv = -S \dots \dots \dots (1.)$$

A given value of S expresses the work required to overcome molecular forces, in expanding unity of weight of a fluid from a given state, to that of perfect gas; and the excess of the actual heat of the fluid above this quantity, or

$$k\tau - S, \dots \dots \dots (1 A.)$$

is the *intrinsic energy* of the fluid, or the energy which it is capable of exerting against a piston, in changing from a given state as to temperature and volume, to a state of total privation of heat and indefinite expansion. In fig. 93, the values of the intrinsic energy of the fluid in the conditions A and B are represented respectively by the indefinitely prolonged areas $X V_A A M$, $X V_B B N$. The quantity above denoted by S is the same with that denoted by the same symbol in Article 238. Let the suffixes a , b , denote the states of the fluid at the beginning and end of any given series of changes of temperature and volume, and $H_{a,b}$, the supply of heat from an external source necessary to produce those changes, expressed in foot-pounds; then

$$H_{a,b} - \int_{v_a}^{v_b} p dv = (k\tau - S)_b - (k\tau - S)_a; \dots \dots \dots (2.)$$

that is to say, *the excess of the heat absorbed above the external work*

performed is equal to the increase of the intrinsic energy; so that this excess depends on the initial and final states only, as already shown in Article 238.

248. **Expression of the Thermodynamic Function in Terms of the Temperature and Pressure.**—The volume of unity of weight of a fluid v , its expansive pressure p , and its absolute temperature τ , form a system of three quantities, of which, when any two are given, the third is determined. In the preceding Articles, the volume and temperature are taken as independent variables, and the pressure is expressed as a function of them. In some investigations it is convenient to take the pressure and temperature as independent variables, the volume being expressed as their function. The following expression of the thermodynamic function in terms of this pair of independent variables is taken from an unpublished continuation, now in the hands of the Royal Society of Edinburgh, of a series of papers already referred to. Let τ_0 , as before, be the absolute temperature of melting ice; $p_0 v_0$, the product of the pressure and volume of unity of weight of the fluid, in the perfectly gaseous state, at that temperature (of which quantity examples are given in Table II., at the end of the volume); then

$$\phi = \left(k + \frac{p_0 v_0}{\tau_0} \right) \text{hyp log } \tau - \int_0^p \frac{d v}{d \tau} \cdot d p \dots \dots (1.)$$

By the aid of the above equation, and of the following well known theorem:—

$$\int_{v_a}^{v_b} p d v = \int_{p_a}^{p_b} v d p + p_b v_b - p_a v_a \dots \dots (2.)$$

all the equations of the preceding sections are easily transformed.

The graphic representation of the quantity denoted by the second

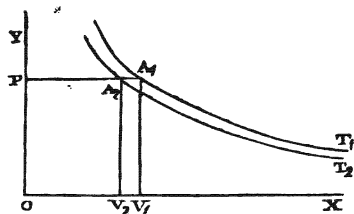

Fig. 95.

term of equation 1 is of the following kind (see fig. 95):—Let abscissæ measured along O X represent volumes occupied by one pound of the substance. Let ordinates parallel to O Y represent pressures exerted by it. It is required to find the second term of the thermodynamic function for the condition of the substance corresponding to the

point A_1 on the diagram, whose co-ordinates are $\overline{O V_1} = v$, and $\overline{O P} = \overline{V_1 A_1} = p$; the absolute temperature being τ . Let $A_1 T_1$ be the isothermal curve of τ . Then the indefinitely extended area $X O P A_1 T_1$ is what is represented by

$$\int_0^P v \, dp.$$

Let $A_2 T_2$ be the isothermal curve corresponding to the absolute temperature $\tau - \Delta \tau$, and cutting $\overline{A_1 P} \parallel OX$ in A_2 . Then the symbol

$$\int_0^P \frac{dv}{d\tau} \, dp$$

represents the limit towards which the quotient

$$\frac{\text{area } T_2 A_2 A_1 T_1}{\Delta \tau}$$

approximates, when $\Delta \tau$ is indefinitely diminished.

By using the form of the thermodynamic function explained in this Article, the general equation of the expansive action of heat in a fluid is made to take the following form:—

$$J \, d h = d H = \tau \, d \phi = \left(k + \frac{p_0 v_0}{\tau_0} - \tau \int_0^P \frac{d^2 v}{d \tau^2} \, dp \right) d \tau - \tau \frac{d v}{d \tau} \, dp ; \dots \dots \dots (3.)$$

a form which is convenient in cases where the pressure and its mode of variation are amongst the primary data of the problem.

It will be shown in a subsequent Article, that the constant part

$$k + \frac{p_0 v_0}{\tau_0}$$

of the co-efficient of $d \tau$, is the *dynamical specific heat of the fluid, in the state of perfect gas, under a constant pressure.*

249. **Principal Applications of the Laws of the Expansive Action of Heat.**—The relation between the temperature, pressure, and volume of one pound of any particular substance being known by experiment, the principles of the preceding Articles serve to compute the quantity of heat which will be absorbed or rejected by one pound of that substance under given circumstances; and conversely, in some cases when the quantities of heat absorbed or rejected under given circumstances are known by experiment, the same principles serve to determine relations between the temperature, pressure, and density of the substance. The chief subjects to which the principles of the expansive action of heat are applicable, are the following:—Real and apparent specific heat; the heating and cooling of gases and vapours by compression and expansion; the

velocity of sound in gases; the free expansion of gases; the flow of gases through orifices and pipes; the latent and total heat of evaporation of fluids; the latent heat of fusion; the efficiency of thermodynamic engines. The last of those subjects is that to which this treatise specially relates; but in order to make it intelligible, it is necessary in the first place to give a summary of the principles of the subjects enumerated before it.

250. **Real and Apparent Specific Heat.**—These terms have been explained in a previous Article. The symbolical expression for the apparent specific heat of a given substance, stated in units of work per degree of temperature in unity of weight, is as follows:—

$$Jc = K = \frac{dH}{d\tau} = \tau \frac{d\phi}{d\tau} = k + \frac{\tau d \cdot \frac{dU}{d\tau}}{d\tau} \dots\dots (1.)$$

In which the term k is the real specific heat, or that which actually makes the substance hotter, being a constant quantity; while the other term represents the heat which disappears in performing work, internal and external, for each degree of rise of temperature.

The co-efficients $\frac{d\phi}{d\tau}$ and $\frac{d \cdot \frac{dU}{d\tau}}{d\tau}$, represent respectively the

complete rates of variation with temperature of the thermodynamic function and heat-potential, under the circumstances of the particular case. With respect to liquids and solids, it is impossible to regulate artificially the mode of variation of the thermodynamic function to an extent appreciable in practice. For substances in these states, the apparent specific heat increases with rise of temperature at a rate which is slow, but which appears, as theory would lead us to expect, to be connected with the rate of expansion. For gases, the mode of variation of the thermodynamic function with temperature may be regulated artificially in an arbitrary manner, so as to vary the apparent specific heat in an indefinite number of ways. It is customary, however, to restrict the term "Specific heat" in speaking of gases, to two particular cases; that in which the volume is maintained constant during the variation of temperature, and that in which the pressure is maintained constant, as formerly explained in Article 210. The specific heat at *constant volume*, is expressed as follows, in units of work per degree, being deduced from the expression for the thermodynamic function in Article 246, equation 1:—

$$Jc_v = K_v = k + \tau \int_{\alpha}^v \frac{d^2 p}{d\tau^2} dv \dots\dots\dots (2.)$$

For a theoretically perfect gas,

$$K_v = k \dots\dots\dots(2A.)$$

The specific heat under *constant pressure*, deduced from the expression for the thermodynamic function in Article 248, equation 1, is as follows :—

$$J c_p = K_p = k + \frac{p_0 v_0}{\tau_0} - \tau \int_0^p \frac{d^2 v}{d \tau^2} \cdot dp \dots\dots\dots(3.)$$

For a perfect gas,

$$K_p = k + \frac{p_0 v_0}{\tau_0}, \dots\dots\dots(3A.)$$

being simply the real specific heat increased by the work performed by unity of weight of the gas in undergoing, at any constant pressure, the expansion corresponding to one degree of rise of temperature ; a quantity of work which is constant for a given perfect gas under all circumstances. The quantities $\frac{d^2 p}{d \tau^2}$ and $\frac{d^2 v}{d \tau^2}$, representing the deviation of the laws of the elasticity of actual gases from those of the ideal condition of perfect gas, are so small, that their effects on apparent specific heat, though *calculable*, fall within the probable limits of errors of observation in the direct experiments hitherto made on the specific heat of the more common gases, such as air and carbonic acid. Referring, therefore, to the detailed papers already cited in the *Trans. of the Royal Society of Edinburgh*, vol. xx., for computations of the effects of such deviations, it will be sufficient for practical purposes to consider the specific heats of gases as represented by the formulæ 2A and 3A. The specific heats of gases, as expressed in the customary way, by their ratios to that of water, are found by dividing the quantities in these formulæ by Joule's equivalent (J), and may be thus expressed :—

$$c_v = \frac{K_v}{J} ; c_p = \frac{K_p}{J} \dots\dots\dots(4.)$$

Examples of specific heat, stated in both ways, are given in Table II., at the end of the volume. Before the period of M. Regnault's experiments on a great variety of gases and vapours, published in the *Comptes Rendus* for 1853, no trustworthy direct experimental determination of the specific heat of any gas or vapour existed, except an approximate determination by Mr. Joule, made in 1852, of the specific heat of air ; for the results formerly relied upon have been shown to be erroneous. In one of the papers referred to in the preceding Article, however (*Edinburgh Transactions*, 1850), the

dynamical specific heats of air had been computed from the following data:—

$p_0 v_0$, from M. Regnault's experiments 26214 foot-pounds. $\tau_0 = 493^{\circ}2$ Fahrenheit.

$$\therefore K_p - K_v = \frac{p_0 v_0}{\tau_0} = 53.15 \text{ foot-pounds per degree of Fahrenheit}$$

heat; being the energy exerted by one pound of air in undergoing, at a constant pressure, the expansion corresponding to one degree of rise of temperature, and the mechanical equivalent of the latent heat of expansion of the air under those circumstances, which (as stated in Article 212) is 0.069 of a British thermal unit, = 53.15

$$\frac{772}{}$$

$\gamma = \frac{K_p}{K_v}$, as deduced from the velocity of sound in air, assumed in the paper referred to as approximately = 1.4; but a more exact value is 1.408. Consequently,

$K_v = \frac{p_0 v_0}{\tau_0} \cdot \frac{1}{\gamma - 1} = \frac{53.15}{0.408} = 130.3$ foot-pounds per degree of Fahrenheit.

$K_p = \frac{p_0 v_0}{\tau_0} \cdot \frac{\gamma}{\gamma - 1} = 53.15 \times \frac{1.408}{0.408} = 130.3 + 53.15 = 183.45$ foot-pounds per degree of Fahrenheit. Hence is deduced the following ratio of the specific heat of air under constant pressure to that of water,

$$c_p = \frac{K_p}{J} = \frac{183.45}{772} = \dots\dots\dots 0.2377.$$

c_p , according to M. Regnault's experiments, published	}	$\frac{0.2379}{}$
in 1853,.....		
Difference,.....		$\frac{0.0002}{}$

* In the calculation published in 1850, γ was assumed = 1.4, and c_p was computed as = 0.24; but the calculation just given being founded on a more accurate value of γ , is of course to be preferred as a test of the dynamical theory of heat. Mr. Joule's approximate determination in 1852 was 0.23. According to the dynamical theory of heat, the apparent specific heat of a gas under constant pressure is *sensibly the same at all pressures and temperatures*, if the gas is nearly perfect. According to the hypothesis of *substantial caloric*, that specific heat *diminishes as the pressure increases*, according to a law which is stated in many treatises on physics, even of the most recent dates (in some, indeed, as confidently as if it were an observed fact). The experiments of M. Regnault, by which the specific heat of air under constant pressure was determined at various temperatures from -22° Fahr. up to 437° Fahr., and at various pressures of from *one to ten* atmospheres, and found to be *sensibly the same* under all these circumstances, constitute "experimenta crucis" conclusive against

251. **Heating and Cooling of Gases and Vapours by Compression and Expansion.**—If a substance wholly or partially in the state of gas or vapour be enclosed in a vessel which does not conduct any appreciable amount of heat to or from the substance, then the compression and expansion of the substance through variations of the volume of the vessel will produce respectively heating and cooling, according to a law expressed by the condition, that the *thermodynamic function is constant*.

The following equations contain two modes of expressing this condition, deduced from the expressions in Articles 246 and 248 respectively :—

$$k \text{ hyp log } \tau + \int_{\alpha}^v \frac{d p}{d \tau} d v = \text{constant,(1)}$$

$$\left(k + \frac{p_0 v^0}{\tau_0} \right) \text{ hyp log } \tau - \int_0^p \frac{d p}{d \tau} d p = \text{constant, ... (2)}$$

and each of those is the equation of an *adiabatic curve*.

For a perfect gas, we have

$$\frac{d p}{d \tau} = \frac{p_0 v_0}{\tau_0 v}; \text{ and } \frac{d v}{d \tau} = \frac{p_0 v_0}{\tau_0 p}; \text{ (3)}$$

hence let $p_1 v_1$ correspond to one given absolute temperature τ_1 , and $p_2 v_2$ to another given absolute temperature τ_2 ; then for a perfect gas, or a gas sensibly perfect,

$$\left. \begin{aligned} \log \frac{\tau_2}{\tau_1} &= (\gamma - 1) \log \frac{v_1}{v_2} = \frac{\gamma - 1}{\gamma} \cdot \log \frac{p_2}{p_1}; \\ \text{or, } \frac{\tau_2}{\tau_1} &= \left(\frac{v_1}{v_2} \right)^{\gamma - 1} = \left(\frac{p_2}{p_1} \right)^{\frac{\gamma - 1}{\gamma}}. \end{aligned} \right\} \text{ (4)}$$

These equations give, for the law of expansion of a perfect gas, without receiving or emitting heat, the following relation between the pressure and the volume,

$$p \propto \frac{1}{v^\gamma}, \text{ (5)}$$

and this is the simplest form of the equation of an adiabatic curve for a perfect gas. The values of the several exponents in equations 4 and 5 for AIR are,

that "idolon fori," the hypothesis of caloric. Those experiments also afford evidence of the fact, that the scale of the air thermometer sensibly agrees with that of absolute temperatures.

$$\gamma = 1.408$$

$$\gamma - 1 = 0.408$$

$$\frac{1}{\gamma - 1} = 2.451$$

$$\frac{\gamma}{\gamma - 1} = 3.451$$

$$\frac{1}{\gamma} = 0.71$$

$$\frac{\gamma - 1}{\gamma} = 0.29$$

For STEAM in the perfectly gaseous state, taking (as in Article 202, equation 4), $p_0 v_0 = 42141$, and according to M. Regnault's experiments, $K_p = 772 \times 0.475 = 366.7$, we find,

$$\gamma = 1.304$$

$$\gamma - 1 = 0.304$$

$$\frac{1}{\gamma - 1} = 3.29$$

$$\frac{\gamma}{\gamma - 1} = 4.29$$

$$\frac{1}{\gamma} = 0.767$$

$$\frac{\gamma - 1}{\gamma} = 0.233$$

These values, however, are not so certain as those of the corresponding quantities for air. From equation 1 is easily deduced the law of the variation of the pressure with the volume of any fluid, whether perfectly gaseous or not, enclosed in a non-conducting vessel, viz. :—*the rate of variation of the pressure with the volume when the fluid is enclosed in a non-conducting vessel, exceeds the rate of variation when the temperature is constant, in the ratio of the apparent specific heat of the fluid at constant pressure to its apparent specific heat at constant volume*:—a law expressed symbolically as follows :—

$$\frac{d \cdot p}{d \cdot v} = - \gamma \cdot \frac{\frac{d p}{d \tau}}{\frac{d v}{d \tau}} \dots\dots\dots(6.)$$

For a perfect gas this becomes,

$$\frac{d \cdot p}{d \cdot v} = - \gamma \cdot \frac{p}{v},$$

as equation 5 also shows. The cooling of air by expansion has been applied by Dr. Gorrie to the manufacture of ice, and by Professor Piazzi Smyth to ventilation.

252. *Velocity of Sound in Gases.**—The velocity of sound in any fluid is well known to be equal to that acquired by a heavy body in falling through one-half of the height which represents the variation of the pressure of the fluid with its density during a sudden change of density. That is to say, let a be the velocity of sound in feet per second, g the accelerating force of gravity in a second = 32.2 feet per second, D the weight of one cubic foot of the fluid in pounds = $\frac{1}{v}$, and p its elastic pressure in pounds per square foot, then

$$a = \sqrt{g \cdot \frac{d p}{d D}} \dots \dots \dots (1.)$$

During the transmission of a wave of sound, the compression and expansion of the particles of a fluid take place so rapidly, that there is not time for any appreciable transmission of heat between different particles,† and the variations of the pressure and density are related to each other as they would be in a non-conducting vessel; consequently, if h represents the rate of variation of pressure with density at a constant temperature, then it follows from the principle of equation 6, Art. 251, that $\frac{d p}{d D} = \gamma h$, and

$$a = \sqrt{g \gamma h} \dots \dots \dots (2.)$$

This equation was proved long ago by Laplace and Poisson, for perfect gases, for which

$$h = p v = \frac{p_0 v_0}{\tau_0} \cdot \tau \dots \dots \dots (3.)$$

but it is true, as we have seen, for all fluids whatsoever.

Applying the formula to air, considered as a sensibly perfect gas, with the following data:—

* In this Article the sounds are supposed to be of moderate intensity, so that there is no sensible acceleration of the sound due to the cause investigated by Mr. Earnshaw: as to which see *Proc. Roy. Soc.*, 1859.

† Proved by Prof. G. G. Stokes.

$$\gamma = 1.408; p_0 v_0 = 26214; \tau = \tau_0;$$

The following is found to be the velocity of sound in Feet
per second.
pure dry air at the temperature of melting ice, 1090.2

The velocity by experiment is—

According to MM. Bravais and Martins, 1090.5
According to MM. Moll and Van Beek, 1090.1

Experiments on the velocity of sound serve to determine the ratio γ of the specific heats of a gas at constant pressure and at constant volume. For oxygen, hydrogen, and carbonic oxide, it is sensibly the same as for air; for carbonic acid, considerably less.—(*Edinburgh Transactions*, vol. xx.)

253. **Free Expansion of Gases and Vapours.**—When the expansion of a gas takes effect, not by enlarging the vessel in which it is contained, and so performing work on external bodies, but by propelling the gas itself from a space in which it is at a higher pressure p_1 into a space in which it is at a lower pressure p_2 , a portion of energy represented by

$$\int_{p_2}^{p_1} v dp$$

is employed wholly in agitating the particles of the gas; and when the agitation so produced has entirely subsided through the mutual friction of those particles, an equivalent quantity of heat is developed, which neutralizes the previous cooling, wholly if the gas is perfect, partially if it is imperfect. The equation representing the result of this process is the following:—

$$\int_{\phi_1}^{\phi_2} \tau d\phi = \int_{p_2}^{p_1} v dp \dots\dots\dots(1.)$$

In this equation, let the thermodynamic function be expressed in terms of the temperature and pressure, as in Article 248, and let K_p be put for its own value, according to Article 250, equation 3; then we have

$$\int_{\tau_2}^{\tau_1} K_p \cdot d\tau = \int_{p_2}^{p_1} \left(\tau \frac{dv}{d\tau} - v \right) dp \dots\dots\dots(2.)$$

This quantity represents the amount whereby the heat reproduced by friction falls short of that which disappears during the expansion, and for a perfect gas is null. The phenomenon here in question was first employed by Mr. Joule, and Professor William Thomson, jointly, to determine experimentally the relation between the absolute scale of temperature, and that of the air thermometer, which had previously been to a considerable extent a matter of

conjecture and hypothesis. In such experiments the variation of temperature which takes place is very small, hence we may put approximately

$$K_1 \Delta \tau = \left(\tau \frac{d}{d\tau} - 1 \right) \int_{p_2}^{p_1} v dp \dots \dots \dots (3.)$$

where τ is the mean of τ_1 and τ_2 , and

$$\Delta \tau = \tau_1 - \tau_2$$

is the final cooling effect. Let T represent temperature measured by the air thermometer on the ordinary scale, and k the dynamical specific heat of the gas under constant pressure as referred to this scale, which is formed by multiplying the specific heat as given by M. Regnault, by Joule's equivalent. Let the absolute temperature τ be regarded as a function of T ,

$$\tau = f(T)$$

whose form is to be ascertained. Then for equation 3 we may put

$$k \Delta T = \left(\frac{f'(T)}{f(T)} \cdot \frac{d}{dT} - 1 \right) \int_{p_2}^{p_1} v dp \dots \dots \dots (4.)$$

Each experiment, on cooling by free expansion, gives a value of the cooling effect ΔT , corresponding to a particular pair of pressures p_1, p_2 . The relations between p, v , and T , are given by formulæ, founded on M. Regnault's experiments on the elasticity of gases, and already exemplified in Article 202, equations 2 and 3. Consequently from each experiment on free expansion, there can be calculated the value of $\frac{f'(T)}{f(T)} = \frac{d \cdot \log_e \tau}{dT}$, for a particular temperature T on the air thermometer. This function, when multiplied by Joule's equivalent, is called "Carnot's Function," being a function of which Carnot pointed out the existence, but failed, from reasons stated in the historical sketch, to discover the form. Those experiments on free expansion, so far as they have yet been carried (having been made on air and carbonic acid), indicate, that the absolute zero of heat does not appreciably differ from that of gaseous tension, and that the scale of absolute temperature sensibly coincides with that of the perfect gas thermometer. (*Phil. Trans.*, 1854.) This fact having been established, experiments on free expansion become an easy and accurate means of ascertaining the relations between the pressures, temperatures, and densities of various elastic fluids. Experiments on the free expansion of steam

have been made by Mr. C. W. Siemens, and show (as theory leads us to expect), that steam, after having been freely expanded, is *superheated*, or above the temperature of saturation corresponding to its pressure.

254. Flow of Gases.—The principles of the flow of a perfect gas through an orifice, as deduced from the laws of thermodynamics, were investigated in 1856 by Messrs. Thomson and Joule (see *Proc. Roy. Soc.*, May, 1856), and by Professor Julius Weisbach (*Civilingenieur*, 1856). The demonstration of those principles is given in *A Manual of Applied Mechanics*, Articles 637, 637 A. For the purposes of the present treatise, it is unnecessary to give more than the results.

Let the pressure, density, and absolute temperature of a gas within a vessel be $p_1, \frac{1}{v_1}, \tau_1$, and without the vessel, $p_2, \frac{1}{v_2}, \tau_2$;

Let O be the area of an orifice through which the gas escapes from the vessel;

k , a *co-efficient of contraction*, or of *efflux*, so that the *effective area* of the orifice is $k O$;

u , the maximum velocity which the particles of the gas acquire in escaping, when there is no friction;

W , the weight of the gas which escapes in a second; then,

$$u = \sqrt{\left\{ \frac{2g\gamma}{\gamma-1} \cdot \frac{p_0 v_0 \tau_1}{\tau_0} \cdot \left(1 - \left(\frac{p_2}{p_1} \right)^{\frac{\gamma-1}{\gamma}} \right) \right\}}; \dots (1.)$$

$$W = \frac{k O u}{v_2} = k O u \cdot \frac{\tau_0 p_1}{p_0 v_0 \tau_1} \cdot \left(\frac{p_2}{p_1} \right)^{\frac{1}{\gamma}} \dots (2.)$$

The value of the co-efficient of efflux k has been found experimentally by Professor Weisbach, for air with various forms of outlet, with the following results:—

Conoidal mouthpieces, of the form of the contracted vein, with effective pressures of from	} k	0·965 to 0·985
·23 to 1·1 atmosphere,.....		
Circular orifices in thin plates,.....		0·555 to 0·787
Short cylindrical mouthpieces,.....		0·730 to 0·833
The same, rounded at the inner end,.....		0·927
Conical converging mouthpieces, the angle of convergence about 7° 9',.....	}	0·910 to 0·964

For further details, see Professor Weisbach's paper in the *Civilingenieur*.

The principles of the flow of liquids may be applied without sensible error, to gases made to flow by small differences of pressure, as in the case of the draught of chimneys, Article 233.

255. **Latent Heat of Evaporation.**—It is known by experiment, that the pressure under which a fluid boils at a given temperature (being the least pressure under which it can exist in the liquid state, and the greatest under which it can exist in the gaseous state, at the given temperature), is a function of the temperature only (see Article 206, Division III., page 237, and Tables IV., V., and VI., at the end of the volume). Let v' be the volume occupied by one pound of a fluid, when in the liquid state, at the absolute temperature τ , and under the corresponding pressure of ebullition p , and v the volume of the same weight when in the state of saturated vapour at the same pressure and temperature. Then on applying equation 2, of Article 246, to this case, we find that because the temperature is constant, the first term is $= 0$; and because the pressure is constant, the factor $\tau \frac{dp}{d\tau}$ of the second term is constant; so that the integral is

$$H = \tau \frac{dp}{d\tau} (v - v'), \dots \dots \dots (1.)$$

which is the value in units of work of the heat which disappears in evaporating one pound of the fluid at the given temperature. Now suppose the weight of fluid evaporated to be $\frac{1}{v - v'}$; that is to say, so much of the fluid, that its increase of bulk in the act of evaporating is one cubic foot; then

$$L = \frac{H}{v - v'} = \tau \frac{dp}{d\tau} \dots \dots \dots (2.)$$

will be the *latent heat of evaporation in foot-lbs. per cubic foot of space*. This law enables us to compute the quantity of heat expended in propelling a piston through a given space, by means of a given vapour *at full pressure* and at any temperature, simply from the relation between the temperature and the pressure of ebullition, and without knowing the density of the vapour. The rate of increase of the pressure of ebullition with the temperature, $\frac{dp}{d\tau}$, may be computed either from a table of such pressures for the fluid in question (such as those given by M. Regnault in the *Memoires* and *Comptes Rendus* of the Academy of Sciences), or from formulæ of the following form, deduced from that given in Article 206, Division III. :—

$$L = \tau \frac{dp}{d\tau} = p \left(\frac{B}{\tau} + \frac{2C}{\tau^2} \right) \text{hyp log } 10 \dots \dots \dots (3.)$$

(hyp log 10 = 2.3026 nearly).

For the values of B and C for certain fluids, see the table in page 237. p is of course to be computed in lbs. on the *square foot*.

This was the formula employed in computing the numbers in the columns headed L in Tables IV. and V. at the end of the volume.

256. Computation of the Density of Vapour from the Latent Heat.—As has been stated in Article 202, and in Article 206, Division III., the densities of vapours are but imperfectly known by direct experiment. The density of a vapour at saturation at a given temperature may be computed indirectly in the following manner:—Let L be, as above, the latent heat per cubic foot, and H the latent heat per pound of the fluid, ascertained by experiments (such as those of M. Regnault on water, and of Dr. Andrews on other fluids). Then

$$v - v' = \frac{H}{L} \dots \dots \dots (1.)$$

is the increase of volume of one pound of the fluid in evaporating, from which the density of the vapour is easily calculated. The densities, thus computed, of the vapours of æther and sulphuret of carbon, at their boiling points under the mean atmospheric pressure (2116.4 lb. per square foot) agree almost exactly with those computed from the chemical composition of those vapours, supposing them to be perfectly gaseous. The densities of the vapours of water and alcohol as computed from their latent heats of evaporation, are greater than those corresponding to the perfectly gaseous state. For steam at low pressures the difference is trifling, but increases rapidly as the pressure increases. (*Proc. Roy. Soc. Edin.*, 1855.)

Example.— $p = 2116.4$ (one atmosphere).

	Æther.	Bisulph. of Carbon.	Water.
Boiling points (ordinary scale),	95°	114°8	212°
Weight of one cubic foot of vapour—			
Calculated from latent heat,...	0.1853 lb.	0.1829 lb.	0.03790 lb.
Calculated as perfect gas from } chemical composition,..... }	0.1856	0.1830	0.03679
Differences,.....	0.0003	0.0001	0.00111

The quantities, in the column headed D, in Table IV., are the values of $\frac{1}{v - v'}$, as calculated by this method. They agree so nearly with the values of $\frac{1}{v}$, that the difference, though capable of being computed, is unimportant in practice. In Table VI., the

values of v are given in the column headed V. (See the remarks on those tables at the foot of page 231, and top of page 232.)

257. **Total Heat of Evaporation.**—The total heat of evaporation of unity of weight of a fluid, *from* one temperature, *at* another temperature, is the quantity of heat required to raise the temperature of unity of weight of the fluid from the first temperature to the second, and then to evaporate it at the second temperature. Some fixed temperature, such as that of melting ice, is usually taken for the first temperature. It is deducible from equation 3, of Art. 248, that the total heat of evaporation of one pound of a fluid, whose vapour is sensibly a perfect gas, and very bulky as compared with the liquid, *from* τ_0 , *at* τ_1 , is sensibly equal to

$$H_0 + K_r (\tau_1 - \tau_0) \dots \dots \dots (1.)$$

In which H_0 is latent heat of evaporation, in foot-pounds, of the fluid at the temperature τ_0 , and K_r is the dynamical specific heat of its gas under constant pressure. This equation is demonstrated by a different process in the *Edinburgh Transactions* for 1850, vol. xx. The demonstration of a principle which includes it will be given in the next Article. Steam is not a perfect gas; and its total heat of evaporation, as ascertained by experiment, is expressed in foot-pounds, by multiplying equation 2 of Article 215, by Joule's equivalent, as follows:—

$$H_0 + a (\tau_1 - \tau_0); \dots \dots \dots (2.)$$

in which a is a certain constant, less than the specific heat under constant pressure, K_r . According to M. Regnault's experiments, let τ_0 be the absolute temperature of melting ice; then

$$H_0 = 842872 \text{ pounds.}$$

$$a = 235 \text{ foot-pounds per degree of Fahrenheit.*}$$

It is by means of equation 2, that the quantities in the column headed H, in Table VI., at the end of the volume, were computed.

258. **Total Heat of Gasefication.**—The law of the total heat of gasefication has been already stated in Article 215 B (or 216, as it ought to have been numbered). It may be demonstrated, either by the aid of the form of the thermodynamic function given in Article 248, or by a direct process.

The *first method* of demonstration is as follows:—

* The form of equation 2 was hypothetically anticipated by Sir John Lubbock in 1840.

Let $K_r = k + \frac{p_0 v_0}{\tau_0}$ be the *dynamical* specific heat under constant

pressure, of a given substance in the state of perfect gas.

Let T_0 be a temperature so low, that the saturated vapour of the substance is sensibly a perfect gas at that temperature. (This, for example, is the case for water at 32° Fahr.)

Let p_1 be a constant pressure to which the substance is subjected;

Let T_1 be a temperature so high, that at that temperature, and under the pressure p_1 , the substance is sensibly a perfect gas;

Let the substance, by communicating heat to it, be brought from a condition of great density, whether in the liquid or solid state, at T_0 , to the perfectly gaseous condition at T_1 ; under the constant pressure p_1 ;

The volume in the denser condition must be supposed to be inappreciable, when compared with that in the gaseous condition.

The thermodynamic function, as given in Article 248, in terms of the absolute temperature and the pressure as independent variables, is

$$\phi = K_P \text{ hyp log } \tau - \int_0^p \frac{d v}{d \tau} d p \dots \dots \dots (1.)$$

The heat absorbed by the substance, during any indefinitely small change of temperature $d \tau$ and of pressure $d p$, is

$$d H = \tau d \phi = \tau \left(\frac{d \phi}{d \tau} d \tau + \frac{d' \phi}{d p} d p \right) \dots \dots \dots (2.)$$

In the present case, the pressure is constant; and therefore the term in which $d p$ is a factor, vanishes; and the integration to be performed is as follows:—

$$\begin{aligned} H_1 &= \int_{\phi_0}^{\phi_1} \tau d \phi = \int_{\tau_0}^{\tau_1} \tau \frac{d \phi}{d \tau} d \tau \\ &= K_P (\tau_1 - \tau_0) - \int_{\tau_0}^{\tau_1} \int_0^p \frac{d^2 v}{d \tau^2} \cdot d p d \tau \dots \dots \dots (3.) \end{aligned}$$

Now, because the substance, when at the higher limit of temperature τ_1 , is sensibly a perfect gas, the co-efficient $\frac{d^2 v}{d \tau^2}$ at that temperature is sensibly = 0. Therefore the value of the second term of the above formula does not sensibly vary with the higher temperature τ_1 , and is sensibly the same as if τ_1 were = τ_0 . Now in that case we should have

$$H_1 = H_0,$$

H_0 being the *latent heat of evaporation* (in foot-pounds), of one pound of the substance at the temperature τ_0 ; so that, for equation 3, may be substituted the following:—

$$J h_1 = H_1 = H_0 + K_p (\tau_1 - \tau_0) \\ = J h_0 + J c_p (T_1 - T_0) \dots \dots \dots (4.)$$

which is the law formerly stated, when applied to quantities of heat expressed in foot-pounds.

The *second method* of demonstration is as follows:—

In fig. 96, as usual, let abscissæ parallel to $O X$ represent the volumes in cubic feet assumed by one pound of the substance in question, when in the gaseous state (its volumes in the liquid state being neglected as inappreciable when compared with its volumes in the gaseous state), and ordinates, parallel to $O Y$, its pressures in pounds on the square foot. Let TT be the *isothermal curve* for the vapour at a given absolute temperature τ_1 , which, as the vapour is perfectly gaseous, is a common hyperbola, the rectangles of its co-ordinates, such as $\overline{AB} \times \overline{BE}$, $\overline{DC} \times \overline{CF}$, being equal for every point, and represented symbolically by

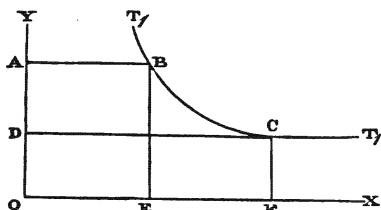

$$p v = p' v' = p_0 v_0 \cdot \frac{\tau_1}{\tau_0} = \text{constant}$$

where $p = \overline{BE}$; $v = \overline{AB}$; $p' = \overline{CF}$; $v' = \overline{DC}$.

Let H, H' denote the values of the total heat of gasefication under the pressures p, p' respectively, for the same limits of temperature, τ_0, τ_1 .

Then, **FIRST**, *The total heat of gasefication is independent of the pressure:* that is, $H' = H$.

This is proved as follows. Let the substance undergo the following cycle of operations:—

I. Gasefication from τ_0 to τ_1 , under the pressure p . In this case,

The heat absorbed is H
 The energy exerted by the fluid on a piston $p v$

II. Expansion at the constant temperature τ_1 , from the volume

v to the volume v' . In this case, as the substance is perfectly gaseous, the heat absorbed and the energy exerted on a piston are *each of them* represented by the area

$$EBCF = ABCD = \int_v^{v'} p dv, = \int_p^P v dp.$$

III. Condensation from τ_1 , and cooling to τ_0 , under the pressure p' . In this case,

The heat *given out* is..... H'
 The energy exerted *by the piston on the fluid*..... $p' v'$.

Hence, the heat which *disappears* during the cycle of operations, is

$$H + \int p dv - H'.$$

The resultant or effective energy exerted by the gas on the piston,

$$= \text{area } ABCD = \int v dp = \int p dv.$$

And by the First Law of Thermodynamics, those quantities are equal; therefore,

$$H - H' = 0; \text{ or } H' = H; \dots\dots\dots$$

—Q. E. D.

SECONDLY, Let H_0 be the latent heat of evaporation at a temperature T_0 , at which the saturated vapour is sensibly a perfect gas, and H_1 the total heat of gasefication at any higher temperature T_1 under any constant pressure. Suppose the gas to be first produced by evaporation at T_0 , and then raised under a constant pressure to T_1 ; the expenditure of heat, in foot-pounds, per pound of gas, will be independent of the pressure, and will be

$$H_1 = H_0 + K_p (T_1 - T_0),$$

as before proved.—Q. E. D.

Taking for T_0 the temperature of melting ice, we have, for steam in the perfectly gaseous condition, or STEAM-GAS,

$$\left. \begin{aligned} H_0 &= 842872 \text{ foot-pounds,} \\ K_p &= 0.475 \times 772 = 366.7 \text{ foot-pounds per degree of} \\ &\quad \text{Fahrenheit above } 32^\circ, \\ H &= 842872 + 366.7 (T - 32^\circ). \end{aligned} \right\} \dots\dots (5.)$$

From this formula have been calculated the numbers in the

$$2116 \times \left(-\frac{d\tau}{dp} \right) = 0^{\circ}\cdot 0133 \text{ Fahrenheit,}$$

a result verified by the experiments of Professor William Thomson.

SECTION 3.—*Efficiency of the Fluid in Heat Engines in general.*

259. **Analysis of the Efficiency of Heat Engines.**—If the number of British thermal units produced by the combustion of one pound of a given kind of fuel, be multiplied by Joule's equivalent, 772 foot-pounds, the result is the *total heat of combustion* of the fuel in question, expressed in foot-pounds. For different kinds of fuel, as may be deduced from the data in Article 227, this quantity, in round numbers, ranges between 5,000,000 and 12,000,000 foot-pounds. This total heat is expended, in any given engine, in producing the following effects, whose sum is equal to the heat so expended :—

1. The *waste heat of the furnace*, being from 0·1 to 0·6 of the total heat, according to the construction of the furnace, and the skill with which the combustion is regulated. See Article 234.

2. The *necessarily-rejected heat of the engine*, being the excess of the whole heat communicated to the working fluid by each pound of fuel burned, above the portion of that heat which permanently disappears, being replaced by mechanical energy.

3. The *heat wasted by the engine*, whether by conduction or by non-fulfilment of the conditions of maximum efficiency.

4. The *useless work of the engine*, employed in overcoming friction and other prejudicial resistances.

5. The *useful work*. The efficiency of a heat engine is improved by diminishing as far as possible the first four of those effects, so as to increase the fifth.

It appears then that the efficiency of a heat engine is the product of three factors; viz :—I. The *efficiency of the furnace*, being the ratio which the heat transferred to the working fluid bears to the total heat of combustion; II. The *efficiency of the fluid*, being the fraction of the heat received by it which is transformed into mechanical energy; and, III., The *efficiency of the mechanism*, being the fraction of that energy which is available for driving machines.

The first of those factors,—the efficiency of the furnace,—has been considered in Chapter II., and especially in Article 234: the second,—the efficiency of the fluid,—is the special subject of the present section; the third will be considered in a subsequent section.

260. **Action of the Cylinder and Piston—Indicated Power.**—The part of a heat engine in which the fluid performs work consists

essentially of an enclosed space whose volume is capable of being alternately enlarged and contracted, by the motion of one of its boundaries. The enclosed space is of a cylindrical form, in all engines that are extensively used in practice; and it is called the **CYLINDER**, even in those exceptional engines in which it has some other figure. Its moveable boundary is called the **PISTON**, and is usually a cylindrical disc fitting the cylinder, in which it moves to and fro in a straight line. In some exceptional engines the piston has other forms, but its action always is to increase and diminish alternately the volume of a certain enclosed space.

The steam or other working fluid, while it is entering the cylinder and expanding, drives the piston before it, and exerts on the piston an amount of energy equal to the product of the volume swept through by the piston into the mean intensity of the pressure of the fluid. This operation is the *forward stroke*.

During the *return*, or *backward stroke*, the piston drives the fluid before it, and either expels it from the cylinder, or compresses it, or expels part and compresses part; and in so doing the piston exerts energy upon the fluid to an amount equal to the product of the volume swept through by the piston into the mean intensity of the pressure of the fluid, which is now called *back pressure*.

The excess of the energy exerted by the fluid on the piston during the forward stroke above the energy exerted by the piston on the fluid during the return stroke, is the *effective energy* exerted by the fluid on the piston during one *complete stroke*, or *revolution*, consisting of a forward stroke and a return stroke, and is equal to the *work performed* by the piston in overcoming resistance other than the back pressure of the fluid; and the amount of that work in some definite time, as a second, a minute, or an hour, is the **INDICATED POWER** of the engine.

The method of computing that power from the diagram drawn by the indicator of a working engine has been explained in Article 43.

It is to be borne in mind in such calculations (as has been explained in Article 6), that the spaces swept through by the piston, and the intensities of the pressure, must be stated in such units that the product of a space into the intensity of a pressure shall give a quantity of work in foot-pounds. Thus, for quantities of work in *foot-pounds*—

UNIT OF PRESSURE.
One lb. on the square foot.
One lb. on the square inch.

UNIT OF SPACE.
One cubic foot.
A prism a foot long and an inch square, = $\frac{1}{144}$ cubic foot;

and for quantities of work in *kilogrammetres*—

UNIT OF PRESSURE.	UNIT OF SPACE.
One kilogramme on the square metre,.....	One cubic metre.
One kilogramme on the square centimetre,.....	
One kilogramme on the square millimetre,.....	$\frac{1}{10,000}$ cubic metre = $\frac{1}{10}$ litre.
	$\frac{1}{1,000,000}$ cubic metre = $\frac{1}{1,000}$ litre.

The method of computing the power of a double-acting engine, by finding separately the quantities of effective energy exerted on the two sides of the piston, and adding them together, has been sufficiently explained and illustrated in Article 43, pages 50, 51.

261. **Double Cylinder Engines—Combination of Diagrams.**—In a double cylinder engine, the steam or other fluid performs its work in two cylinders, a smaller and a larger, which at certain periods communicate with each other. In some cases the functions of two cylinders are performed by the two ends of one cylinder. The details of such engines will be explained in a future chapter; the object of the present Article being to show how the indicator-diagrams of work obtained from a double cylinder engine are to be combined, so as to produce the diagram that would have been obtained had the fluid performed the same work by going through the same series of changes of pressure and volume in one cylinder.

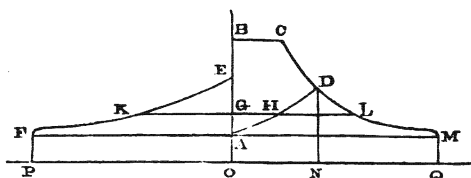

Fig. 97.

To fix the ideas, the fluid will be spoken of as *steam*; although the principles are applicable to any fluid. The steam, then, is first admitted from the boiler into the smaller cylinder, until it fills a certain volume, represented by \overline{BC} in fig. 97; the absolute pressure is represented by the height of \overline{BC} above the zero line \overline{POQ} . The admission of the steam is then cut off, and it expands in the smaller cylinder with a pressure gradually diminishing, as shown by the ordinates of the curve \overline{CD} . \overline{DN} being let fall perpendicular to \overline{OQ} , \overline{ON} represents the whole space swept through by

the piston of the smaller cylinder during its forward stroke. At the end of that stroke, a communication is opened between the smaller and the larger cylinder; and the forward stroke of the piston of the larger cylinder takes place at the same time with the return stroke of the piston of the smaller cylinder. During this process, the steam is driven before the piston of the smaller cylinder, and drives the piston of the larger cylinder; it exerts more energy on the latter piston than it receives from the former, because the piston of the larger cylinder sweeps through the greater space; and the difference between those quantities of energy is added to the energy formerly exerted by the steam on the piston of the smaller cylinder. This part of the action of the steam is represented by the curves DA and EF : the ordinates of DA representing the backward pressures exerted by the steam in the smaller cylinder, and the ordinates of EF , the forward pressures exerted by it at the same time in the larger cylinder. \overline{OP} represents the space swept through by the piston of the larger cylinder, on the same scale with that according to which \overline{ON} represents the corresponding space for the smaller cylinder.

The next operation is to shut the communication between the two cylinders, and open the exhaust port of the larger cylinder, and the admission port of the smaller. Then takes place the return stroke of the larger cylinder, during which the steam is expelled, exerting a back pressure represented by the ordinates of FA ; while at the same time a new portion of steam is admitted into the smaller cylinder, and expanded as before, during a new forward stroke of that cylinder.

Thus are produced the two indicator diagrams, $BCDAB$ for the smaller cylinder, and $EFAE$ for the larger, and the sum of their areas represents the energy exerted on the piston by the quantity of steam which is expended at one stroke. When two such diagrams are taken by an indicator, for the sole purpose of computing the power of an actual engine, they may be drawn on the same or on different scales, and the quantities of work indicated by them may be computed independently, and then added together. Of this a detailed example has already been given in Article 43, page 51.

But if the diagrams are to be used for the purpose of examining into the thermodynamic relations between heat expended and work performed, or for other scientific purposes, it is best to combine them into one diagram, in the following manner:—

Draw any straight line KGH parallel to POQ , and intersecting both diagrams. Produce that line, and lay off upon it

$$\overline{HL} = \overline{KG}.$$

Then $\overline{GL} = \overline{GH} + \overline{KG}$ represents the total volume occupied by the steam, partly in the smaller and partly in the larger cylinder, when its absolute pressure is represented by \overline{OG} ; and L is a point in the indicator diagram which would have been described had the whole action of the steam taken place in the larger cylinder only.

By drawing a sufficient number of parallel lines, such as KL , and laying off the proper distances on them, as above, any number of points such as L may be found, so as to complete the *combined diagram* $BCDLMAB$, whose length $\overline{OQ} = \overline{OP}$ represents the volume swept through by the piston of the larger cylinder; and this diagram may be reasoned about as if it represented the action of the steam in the larger cylinder alone.

It is to be observed, then, as a general principle, that *the energy exerted by a given portion of a fluid during a given series of changes of pressure and volume, depends on that series of changes, and not on the number and arrangement of the cylinders in which those changes are undergone.*

262. **Fluid Acting as a Cushion.**—To determine geometrically the efficiency of a heat engine, it is necessary to know its true indicator diagram; that is to say, the curve whose co-ordinates represent the successive volumes and pressures which the fluid *working the engine* assumes during a complete revolution. This true indicator diagram is not necessarily identical in figure with the diagram described by the engine on the indicator card; for the abscissæ representing volumes in the latter diagram, include not only the volumes assumed by that portion of the fluid, which really performs the work by alternately receiving heat while expanding, and emitting heat while contracting, in such a manner as permanently to transform heat into mechanical energy, but also the volumes assumed by that portion of the fluid, if any, which acts merely as a *cushion* for transmitting pressure to the piston, undergoing, during each revolution, a series of changes of pressure and volume, and then the same series in an order exactly the reverse of the former order, so as to transform no heat permanently to mechanical energy.

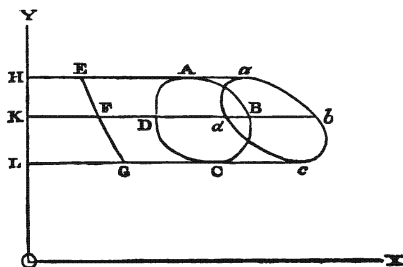

Fig. 98.

In fig. 98, let $abcd$ be the apparent indicator diagram. Parallel to OX draw \overline{Ha} and \overline{Lc} , touching this diagram in a and c respectively;

then those lines will be the lines of maximum and minimum pressure. Let $\overline{H E}$ and $\overline{L G}$ be the volumes occupied by the *cushion* at the maximum and minimum pressures respectively: draw the curve $E G$, such that its co-ordinates shall represent the changes of volume and pressure undergone by the cushion during a revolution of the engine. Let $K F \overline{d b}$ be any straight line of equal pressure, intersecting this curve and the apparent indicator diagram; so that $\overline{K b}$, $\overline{K d}$ shall represent the two volumes assumed by the whole elastic body at the pressure $\overline{O K}$, and $\overline{K F}$ the volume of the cushion at the same pressure. On this line take

$$\overline{b B} = \overline{d D} = \overline{K F};$$

then it is evident that B and D will be two points in the true indicator diagram; and in the same manner may any number of points be found.

The area of the true diagram $A B C D$ is obviously equal to that of the apparent diagram $a b c d$.

263. **Formulae for Energy exerted by Fluid on Piston.** — In fig. 99, let $A B C D E A$ represent the indicator diagram of a heat engine, $O V$ as usual being the line of *no pressure*, and $O P$ that of *no volume*.

The area of that diagram, representing the effective energy exerted by a certain quantity of the fluid, may be computed and expressed by either of two methods.

First Method. — Let the dotted lines $B b$, $E e$, be tangents to the diagram, parallel to $O P$, so that

$$\overline{O e} = v_2; \overline{O b} = v'_1;$$

are respectively the *greatest* and the *least* volumes occupied by the quantity of fluid in question.

Let $\overline{F G} = \Delta v$ represent any small portion of the change of volume undergone by the fluid. Draw $F L H$, $G M K$, perpendicular to $O V$; and let

$$p = \text{mean of } \overline{F H} \text{ and } \overline{G K}, \text{ and}$$

$$p' = \text{mean of } \overline{F L} \text{ and } \overline{G M},$$

represent the mean intensities of the pressures of the fluid when the portion of the change of volume represented by $\overline{F G} = \Delta v$ takes

z

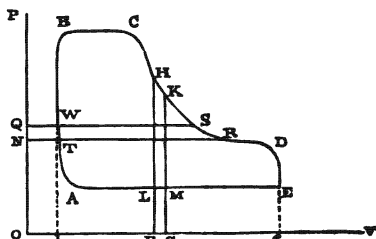

Fig. 99.

place, during the *forward* stroke, and during the *return* stroke respectively, so that

$$p - p'$$

is the *effective* pressure corresponding to F G.

Then,

$$(p - p') \Delta v = \text{area L H K M nearly ;}$$

and by dividing the whole diagram into a number of bands, such as L H K M, and adding their areas together, we get as an approximation to the whole area of the diagram,

$$U = \Sigma \{ (p - p') \Delta v \} \text{ nearly ;}$$

being the value already given in Article 43.

The exact value of that area is the limit towards which that sum approximates, as the bands into which the diagram is divided become more numerous and more narrow. That limit, or *integral*, is represented by the symbol,

$$U = \int_{v_1}^{v_2} (p - p') dv \dots \dots \dots (1.)$$

Second Method.—Let p_1 represent the greatest, and p_2 the least intensity of the pressure of the fluid during its action.

Let $\overline{N Q} = \Delta p$ represent any small portion of the change of pressure undergone by the fluid. Draw N T R, Q W S, perpendicular to O P, and let

$$v = \text{mean of } \overline{N R} \text{ and } \overline{Q S}, \text{ and}$$

$$v' = \text{mean of } \overline{N T} \text{ and } \overline{Q W},$$

represent the mean volumes occupied by the fluid when the portion of the change of pressure represented by $\overline{N Q} = \Delta p$ takes place, during the *forward* stroke and during the *return* stroke respectively.

Then,

$$(v - v') \Delta p = \text{area W S R T nearly ;}$$

and by dividing the whole diagram into a number of bands, such as W S R T, and adding their areas together, we get as an approximation to the whole area of the diagram,

$$U = \Sigma \{ (v - v') \Delta p \} \text{ nearly.}$$

The exact value of that area is the limit towards which that sum approximates, as the bands into which the diagram is divided become more numerous and more narrow. That limit, or *integral*, is represented by the symbol

$$U = \int_{p_2}^{p_1} (v - v') dp; \dots\dots\dots(2.)$$

being a result equal to that given by equation 1, but obtained by a different process.

The first method is the best for measuring the work indicated by the diagrams of actual engines. The second is the most convenient in some theoretical inquiries.

It is always most convenient to consider the quantity of fluid to which the equations 1 and 2 refer, as being ONE POUND; so that they give the *energy exerted per pound of fluid*, and the values of v are simply the various volumes occupied by one pound at different periods of the revolution of the engine.

To express the energy exerted *per unit of space swept through by the piston* (or in a double cylinder engine, by the piston of the larger cylinder), it is to be observed, that the space so swept through per pound of fluid employed, is the difference between the greatest and least volumes occupied by one pound; that is to say,

$$v_2 - v_1;$$

so that, THE ENERGY EXERTED PER UNIT OF VOLUME SWEEP THROUGH

$$= \frac{U}{v_2 - v_1} = \frac{\int (p - p') dv}{v_2 - v_1} = \frac{\int (v - v') dp}{v_2 - v_1}; \dots\dots\dots(3.)$$

If the unit of volume is a *cubic foot*, this formula gives the *mean effective pressure in pounds on the square foot*; if the unit of volume is a prism a foot long and an inch square, the formula gives the *mean effective pressure in pounds on the square inch*.

The ENERGY EXERTED IN A GIVEN TIME (such as a minute, or an hour), that is, the INDICATED POWER, is given by the expression,

$$w U, \dots\dots\dots(4.)$$

in which w is the weight of fluid employed in the given time; or otherwise, as in Article 43, equation 4, by the expression,

$$\frac{N A s U}{v_2 - v_1}; \dots\dots\dots(5.)$$

in which A is the area, and s the length of stroke of the piston (or of the piston of the larger cylinder, in a double cylinder engine); so that $A s$ is the volume swept through per stroke; and N is the number of strokes in the given time; which number, in a double acting engine, is to be doubled, as has been explained in Article 43, unless the quantities of energy exerted on the two sides of the piston are computed separately, and added together.

Inasmuch as we have

$$w = \frac{N A s}{v_2 - v_1}, \dots\dots\dots(6.)$$

it follows that the *weight of fluid employed per stroke* is

$$\frac{w}{N} = \frac{A s}{v_2 - v_1} \dots\dots\dots(7.)$$

If the diagram in fig. 99 is held to represent the energy exerted by *one pound* of the fluid, then the abscissæ parallel to O V represent simply values of v , the volume of one pound.

If the diagram is held to represent the energy exerted *per unit of volume swept through*, then the line $\overline{b e}$ represents that unit, and the abscissæ parallel to O V represent values of

$$\frac{v}{v_2 - v_1} \dots\dots\dots(8.)$$

If the diagram is held to represent the energy exerted during *one stroke*, then the line $\overline{b e}$ represents the volume $A s$, and the abscissæ parallel to O V represent values of

$$\frac{v A s}{v_2 - v_1} \dots\dots\dots(9.)$$

The quantity spoken of as the "*weight of fluid employed*" in every case means, the weight of fluid employed *once*; and if a given weight of fluid (as often happens) is made to act again and again, it is to be held to be equivalent to the same weight *multiplied by the number of times that it is employed*.

264. Equation of Energy and Work.—The principle of the equality of energy and work (Articles 26, 33) when applied to the action of the fluid in a heat engine, takes the following form:—

When the engine is moving with an uniform periodical motion (that is, when each stroke occupies an equal interval of time, and when the velocity of each part of the machine is the same after any number of complete strokes), the energy exerted by the fluid on the piston during any number of complete strokes is equal to the work performed by the piston in overcoming resistance in the same period.

The most convenient method of expressing this principle by a formula is as follows:—

As in Articles 9 and 24, let all the resistances, useful and prejudicial, which the engine has to overcome, be *reduced to the piston as a driving point*. For example, suppose that while the piston performs a stroke, of the length s , a given part of the mechanism

moves through the distance s' , against the resistance R' . Then the equivalent resistance, directly applied to the piston, is

$$\frac{s'}{s} \cdot R';$$

and the *total resistance reduced to the piston*, obtained by adding together all such quantities as the above, may be denoted as follows:—

$$R = \Sigma \cdot \frac{s'}{s} R' \dots \dots \dots (1.)$$

Now if N be taken, as in the last Article, to denote the number of strokes in a given time, such as a minute, the work performed by the piston in that time is

$$N s R = N \cdot \Sigma \cdot s' R'; \dots \dots \dots (2.)$$

and this being equated to the energy exerted by the fluid on the piston in the same time, as given in Article 263, formulæ 4 and 5, gives for the *equation of energy and work*, the following:—

$$N s R = w U = \frac{N A s U}{v_2 - v_1} \dots \dots \dots (3.)$$

Another form of expression for the same principle is obtained by dividing both sides of the above equation by $N s A$, as follows:—

$$\frac{R}{A} = \frac{U}{v_2 - v_1} \dots \dots \dots (4.)$$

Now the first side of this equation is the total resistance per unit of area of piston; and the second side is the mean effective pressure of the fluid; so that the principle expressed by it may be stated as follows:—

In a heat engine moving with an uniform periodical motion, the mean effective pressure of the fluid is equal to the total resistance per unit of area of piston.

The proper mode of applying this principle to the steam engine was first pointed out by the Count de Pambour in his works *On Locomotives*, and on the *Theory of the Steam Engine*. It may be summed up as follows, leaving the details to be explained further on:—

The resistance is in general determined by the nature of the work performed by the engine; so that in most cases, R is known from data independent of the action of the fluid.

The resistance being a fixed quantity, fixes the mean effective pressure according to equation 4; in other words, the action of the

fluid *adjusts itself* until the mean effective pressure balances the resistance. The process by which that adjustment takes place may be stated generally thus:—if the mean effective pressure is at first greater than the resistance, the motion of the engine is accelerated; that is, the number of strokes in a given time is increased; the quantity of heat expended per stroke is diminished; and the mean effective pressure is diminished; and this goes on until the mean effective pressure exactly balances the resistance. If the mean effective pressure is at first less than the resistance, the motion of the engine is retarded until the same adjustment is effected by a process precisely the converse of that above described.

The mean effective pressure being thus determined, the quantities U , $v_2 - v_1$, and the various values of p and v , at different parts of the stroke, can be deduced from it by principles to be afterwards explained, depending on the nature of the fluid, and the manner in which its action is regulated in the particular engine. Then from equation 6 of Article 263, it appears that the number of strokes in a given time can be computed by the formula

$$N = \frac{w(v_2 - v_1)}{A s} \dots \dots \dots (5.)$$

265. **Efficiency of the Fluid in an Elementary Heat Engine.**—An elementary heat engine is one in which the reception of heat by the fluid takes place wholly at one absolute temperature τ_1 , and its rejection wholly at another absolute temperature τ_2 . Consequently, in such an engine, the change between those two limiting temperatures must be made entirely by compression and expansion of the fluid.

In fig. 100, let AB be part of the isothermal line of τ_1 , DC part of that of τ_2 ; and let ADM , BCN , be a pair of adiabatic lines, corresponding respectively to any two thermodynamic functions ϕ_a , ϕ_b , and produced indefinitely towards X . Then will $ABCD$ be the diagram of an elementary heat engine receiving heat at the absolute temperature τ_1 , and rejecting heat at τ_2 . The action of such an engine, during one stroke, consists of four operations, represented by the four sides of the figure $ABCD$, as follows:—

- AB , expansion of the fluid at the higher limit of temperature τ_1 ;
- BC , further expansion, without reception or emission of heat, till the temperature falls to τ_2 ;
- CD , compression of the fluid, at the lower limit of temperature τ_2 ;

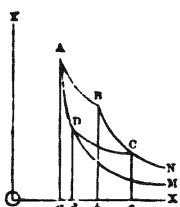

Fig. 100.

D A, further compression, without reception or emission of heat, till the temperature rises again to τ_1 .

The heat received by the fluid from the furnace, at each stroke, during the process A B, is $\tau_1 (\phi_b - \phi_a) = H_1$, and is represented by the indefinitely produced area M A B N. The heat rejected at each stroke, during the process C D, and abstracted by some refrigerating substance (such as the jet of cold water in the condenser of a steam engine) is $\tau_2 (\phi_b - \phi_a) = H_2$, and is represented by the indefinitely-produced area M D C N. The heat permanently transformed into mechanical energy at each stroke is represented by the area A B C D

$$= H_1 - H_2 = (\tau_1 - \tau_2) (\phi_b - \phi_a) \dots \dots \dots (1.)$$

Consequently the *efficiency of the engine* is

$$\frac{H_1 - H_2}{H_1} = \frac{\tau_1 - \tau_2}{\tau_1} = \frac{T_1 - T_2}{T_1 + 461 \cdot 2} \dots \dots \dots (2.)$$

The last equation expresses the *law of the efficiency of elementary thermodynamic engines*, viz. :—that the heat transformed into mechanical energy is to the whole heat received by the fluid as the range of temperature is to the absolute temperature at which heat is received.

266. **Efficiency of the Fluid in Heat Engines in General.**—Let the closed line A a b B c d A be the diagram of any thermodynamic engine. Draw a pair of adiabatic lines A M, B N, touching the closed line in A B, respectively, and indefinitely produced in the direction of O X. Then throughout the process represented by the part A a b B of the diagram, the fluid is receiving heat, and throughout the process is represented by the part B c d A, rejecting heat. Cut an indefinitely narrow band from the diagram by any pair of indefinitely-close adiabatic lines a d m, b c n, corresponding to the thermodynamic functions $\phi, \phi + d\phi$, respectively; and let the absolute temperatures corresponding to the elements a b, c d, be τ_1, τ_2 , respectively. Then, treating the band a b c d as the diagram of an elementary engine, we find (expressing quantities of heat in foot-pounds),

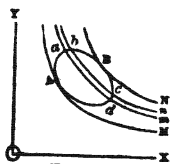

Fig. 101.

- Heat received during the process a b = indefinitely-produced area m a b n = $d H_1 = \tau_1 d \phi$;
- Heat rejected during the process c d = indefinitely-produced area m d c n = $d H_2 = \tau_2 d \phi$;
- Heat transformed into mechanical energy = area a b c d = $d H_1 - d H_2 = (\tau_1 - \tau_2) d \phi$.

Consequently, whole heat received by the fluid,

$$= \text{area } M A a b B N = H_1 = \int_{\phi_A}^{\phi_B} \tau_1 d\phi \dots \dots \dots (1.)$$

Whole heat rejected,

$$= \text{area } M A d c B N = H_2 = \int_{\phi_A}^{\phi_B} \tau_2 d\phi \dots \dots \dots (2.)$$

Heat transformed into mechanical energy,

$$\begin{aligned} &= U = \text{area } A a b B c d A = H_1 - H_2 \\ &= \int (p - p') dv = \int (v - v') dp = \int_{\phi_A}^{\phi_B} (\tau_1 - \tau_2) d\phi \dots \dots \dots (3.) \end{aligned}$$

Efficiency of the engine

$$= \frac{U}{H_1} = \frac{H_1 - H_2}{H_1} = \frac{\int_{\phi_A}^{\phi_B} (\tau_1 - \tau_2) d\phi}{\int_{\phi_A}^{\phi_B} \tau_1 d\phi} \dots \dots \dots (4.)$$

267. **Heat Engine of Maximum Efficiency.**—Between given limits of temperature, the efficiency of a thermodynamic engine is the greatest possible, when the whole reception of heat takes place at the higher limit, and the whole rejection of heat at the lower; that is to say, when the engine is an *elementary engine*; and the efficiency of the fluid in such an engine is independent of the nature of the fluid employed.

268. **Heat Economizer, or Regenerator.**—To fulfil strictly the above condition of maximum efficiency between given limits of temperature, the elevation of the temperature of the fluid must be performed wholly by compression, and the depression of its temperature wholly by expansion; operations which are in many cases impracticable, from the great bulk of cylinders which their performance would require.

This difficulty is almost entirely avoided by the following process for producing alternate elevation and depression of temperature with a small expenditure of heat, invented about the year 1816 by the Rev. Dr. Robert Stirling, and subsequently improved and modified by Mr. James Stirling, Captain Ericsson, Mr. Siemens, and others.

The fluid whose temperature is to be lowered is passed through the interstices of an apparatus called an *economizer* or *regenerator*, formed by a number of thin plates of metal or other solid conducting substance, or by a network of wires, exposing a great surface

within a small space. The material of the economizer becomes heated by the cooling of the fluid. When the temperature of the fluid is again to be raised, it is passed through the interstices of the economizer in the contrary direction, and the heat which it had previously given out is in part restored to it.

It is impossible to perform this process absolutely without waste of heat. In some experiments by Mr. Siemens, on air, the waste of heat at each stroke appears to have been about one-twentieth part of the heat alternately abstracted from and restored to the air; and in the air engines of the ship "Ericsson," about one-tenth.

269. *Isodiabatic Lines.*—One condition of the economical working of the economizer is, that the quantity of heat given out by the fluid during any given stage of the lowering of its temperature shall be equal to the quantity received by it during the corresponding stage of the raising of its temperature. This condition is realized in the following manner:—

Let EF be an arbitrary line representing the mode of variation of the pressure and volume of the fluid during the lowering of its temperature. Let GH be the corresponding line for the raising of the temperature of the fluid. Let KL, MN , be any pair of isothermal lines, intersecting GH in A and D , and EF in B and C , respectively. Let $\phi_A, \phi_B, \phi_C, \phi_D$, be the thermodynamic functions for these four points. Then if, for every possible pair of isothermal lines,

$$\phi_B - \phi_A = \phi_C - \phi_D,$$

the lines EF and GH have the required property, and are said to be *isodiabatic* with respect to each other.

SECTION 4.—Of the Efficiency of Air Engines.

270. *Thermal Lines for Air.*—The ease with which air is obtained in any quantity, and its safety from explosion at high temperatures, have induced many inventors to devise engines in which it is the working fluid.

Very few, however, of those engines have been brought into practical operation, owing chiefly to the difficulty of obtaining a sufficiently rapid convection of heat to and from the mass of air employed, and to the necessity for using a more bulky cylinder than is required for a steam engine of the same power, and with the same maximum pressure.

The efficiency of air engines is here treated of before that of

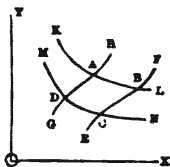

Fig. 102.

steam engines, because of the greater simplicity of its mathematical principles.

In such investigations as the present, air may without sensible error be treated as a perfect gas.

Each *isothermal* line for a perfect gas is a common rectangular hyperbola, whose asymptotes are O X, O Y, its equations being

$$p v = p_0 v_0 \cdot \frac{\tau}{\tau_0} \dots \dots \dots (1.)$$

For air, $p_0 v_0 \div \tau_0 = 53.15$

foot-pounds per degree of Fahrenheit.

Each *adiabatic* line for a perfect gas is a curve of the hyperbolic kind, having O X, O Y, for asymptotes, its equation being

$$p v^\gamma = e^k = \text{constant} \dots \dots \dots (2.)$$

γ for air = 1.408.

See Article 251.

Each *pair of isodiabatic* lines for a perfect gas are so related to each other, that if v, v' , be the abscissæ of the points of intersection of these two lines respectively, with one and the same isothermal line, the ratio $v : v'$ is a constant quantity for all isothermal lines. The same is the case with the ratio $p : p'$. It follows from this, that all straight lines of constant volume, parallel to O Y, are mutually isodiabatic (which is equivalent to saying that the specific heat at constant volume is constant), and also that all straight lines of constant pressure, parallel to O X, are mutually isodiabatic (which is equivalent to saying that the specific heat under constant pressure is constant). See Article 250.

271. *Thermodynamic Functions for Air.*—When the two forms of the thermodynamic function, given respectively in Article 246, and in Article 248, viz,

$$\phi = k \text{ hyp log } \tau + \int \frac{d p}{d \tau} d v ;$$

and

$$\phi = \left(k + \frac{p_0 v_0}{\tau_0} \right) \text{ hyp log } \tau - \int \frac{d v}{d \tau} d p ;$$

are applied to a perfect gas, it is to be observed (as already stated in Article 251), that for a substance in that condition,

$$\frac{d p}{d \tau} = \frac{p}{\tau} = \frac{p_0 v_0}{\tau_0} \cdot \frac{1}{v} ;$$

$$\frac{d v}{d \tau} = \frac{v}{\tau} = \frac{p_0 v_0}{\tau_0} \cdot \frac{1}{p};$$

and also, as has been shown in Article 250, that

$$k = K_v = \frac{p_0 v_0}{(\gamma - 1) \tau_0}; \quad k + \frac{p_0 v}{\tau_0} = K_p = \frac{\gamma p_0 v_0}{(\gamma - 1) \tau_0}$$

These values being introduced under the signs of integration, give the following results:—

$$\phi = \frac{p_0 v_0}{\tau_0} \left(\frac{\text{hyp log } \tau}{\gamma - 1} + \text{hyp log } v \right) + \text{constant} \dots (1.)$$

$$\phi = \frac{p_0 v_0}{\tau_0} \left(\frac{\gamma \text{ hyp log } \tau}{\gamma - 1} + \text{hyp log } p \right) + \text{constant} \dots (2.)$$

In these formulæ, the value assigned to the arbitrary constant introduced by integration is immaterial; because the *differences* between thermodynamic functions have alone to be considered in any problem; and from them the arbitrary constant disappears.

The values of the co-efficients in the above formulæ, for air, though they have already been given in Article 251, may here, for the sake of convenience, be repeated.

$$\left. \begin{aligned} \frac{1}{\gamma - 1} &= 2.451; & \frac{\gamma}{\gamma - 1} &= 3.451; \\ \frac{p_0 v_0}{\tau_0} &= 53.15 \text{ foot-lbs. per degree of Fahrenheit.} \end{aligned} \right\} \dots (3.)$$

In using the formulæ 1 and 2 with tables of *common*, instead of hyperbolic logarithms, it is to be observed that

$$\left. \begin{aligned} \text{hyp log } n &= \text{com log } n \times \text{hyp log } 10; \\ \text{hyp log } 10 &= 2.3026 \text{ nearly;} \\ \frac{p_0 v_0}{\tau_0} \times \text{hyp log } 10 &= 53.15 \times 2.3026 = 122.38 \end{aligned} \right\} \dots (4.)$$

foot-lbs. per degree of Fahrenheit.

272. Perfect Air Engine, without Regenerator.—Fig. 100 (Article 265) may be taken to represent the diagram of the energy exerted by one pound of air during one stroke of an engine of this class.

Let τ_1 and τ_2 be the absolute temperatures of receiving and rejecting heat respectively.

Then A B is part of a common hyperbola, the isothermal curve of τ_1 ; and its equation is

$$p v = \frac{p_0 v_0}{\tau_0} \cdot \tau_1 = 53 \cdot 15 \tau_1 \dots \dots \dots (1.)$$

C D is part of a common hyperbola, the isothermal curve of τ_2 ; and its equation is

$$p v = \frac{p_0 v_0}{\tau_0} \cdot \tau_2 = 53 \cdot 15 \tau_2 \dots \dots \dots (2.)$$

B C and D A are portions of adiabatic curves, whose equations are of the form given in Article 270, equation 2.

Let

$$p_a, p_b, p_c, p_d,$$

$$v_a, v_b, v_c, v_d,$$

denote respectively the pressures in lbs. on the square foot, and the volumes in cubic feet, of one lb. of air, corresponding to the four angles of the diagram, A, B, C, D. Then the *proportions* of those quantities are regulated by the following formulæ:—

$$\frac{p_a}{p_b} = \frac{v_b}{v_a} = \frac{p_d}{p_c} = \frac{v_c}{v_d} = r; \dots \dots \dots (3.)$$

$$\frac{p_a}{p_d} = \frac{p_b}{p_c} = \left(\frac{\tau_1}{\tau_2} \right)^{\frac{\gamma}{\gamma-1}} = \left(\frac{\tau_1}{\tau_2} \right)^{3 \cdot 451} \dots \dots \dots (4.)$$

$$\frac{v_d}{v_a} = \frac{v_c}{v_b} = \left(\frac{\tau_1}{\tau_2} \right)^{\frac{1}{\gamma-1}} = \left(\frac{\tau_1}{\tau_2} \right)^{2 \cdot 451} \dots \dots \dots (5.)$$

In equation 3, r denotes the *ratio of expansion and compression of the air at constant temperature*, which is arbitrary, and is to be fixed by considerations of convenience.

If a certain quantity of air is confined within the engine, and used over and over again to drive the piston, the absolute values of the pressures and volumes whose ratios are given in equations 3, 4, and 5, are arbitrary also. But if the air is wholly or partly discharged at each stroke, and a fresh supply of air taken in from the atmosphere, the minimum pressure p_c , maximum volume v_c of one lb. of air, and temperature of rejection of heat $\tau_2 = p_c v_c \div 53 \cdot 15$, are fixed, being those of the external air. If the temperature τ_1 of receiving heat is also fixed, then the pressure and volume p_b, v_b , are fixed by the formulæ

$$p_b = p_c \cdot \left(\frac{\tau_1}{\tau_2} \right)^{3 \cdot 451}; \quad v_b = v_c \cdot \left(\frac{\tau_2}{\tau_1} \right)^{2 \cdot 451}; \dots \dots \dots (6.)$$

so that nothing remains arbitrary except the ratio r , of expansion and compression at constant temperature, which having been fixed

according to convenience, fixes the other limits of pressure and volume, viz,

$$p_a = r p_b; p_d = r p_c; v_a = \frac{v_b}{r}; v_d = \frac{v_c}{r} \dots\dots\dots(7.)$$

Let ϕ_a, ϕ_b , be the thermodynamic functions proper to the curves A D, B C, respectively. Then according to Article 271, equations 1, 3, and 4, the difference of those functions is

$$\left. \begin{aligned} \phi_b - \phi_a &= \frac{p_0 v_0}{\tau_0} (\text{hyp log } v_b - \text{hyp log } v_a) \\ &= 53 \cdot 15 \text{ hyp log } r \\ &= 122 \cdot 38 \text{ com log } r \end{aligned} \right\} \dots\dots\dots(8.)$$

being a function of the *ratio of expansion at constant temperature* alone.

Introducing this value into the general equations of Article 265, we find the following results:—

Whole expenditure of heat in foot-pounds of energy, per pound of air per stroke—

$$H_1 = \tau_1 (\phi_b - \phi_a) = 53 \cdot 15 \tau_1 \cdot \text{hyp log } r = 122 \cdot 38 \tau_1 \cdot \text{com log } r; \dots(9.)$$

Heat rejected and abstracted by refrigerating apparatus—

$$H_2 = \tau_2 (\phi_b - \phi_a) = 53 \cdot 15 \tau_2 \cdot \text{hyp log } r = 122 \cdot 38 \tau_2 \cdot \text{com log } r; \dots(10.)$$

Mechanical energy exerted on piston—

$$\begin{aligned} U &= H_1 - H_2 = (\tau_1 - \tau_2) (\phi_b - \phi_a) = 53 \cdot 15 (\tau_1 - \tau_2) \text{ hyp log } r \\ &= 122 \cdot 38 (\tau_1 - \tau_2) \text{ com log } r \dots\dots\dots(11.) \end{aligned}$$

Efficiency of fluid (as in the general case)—

$$\frac{H_1}{U} = \frac{\tau_1 - \tau_2}{\tau_1} \dots\dots\dots(12.)$$

If it were possible to perform the whole cycle of operations on the air in one cylinder, the *space to be swept through* by the piston, per pound of air per stroke, would be the difference between the greatest and least volumes of a pound of air; that is to say,

$$v_b - v_a = v_a \left\{ 1 - \frac{1}{r} \left(\frac{\tau_2}{\tau_1} \right)^{2 \cdot 451} \right\}; \dots\dots\dots(13.)$$

and the *mean effective pressure* would be

$$\frac{U}{v_s - v_a} = \frac{p_s \left(\frac{\tau_1}{\tau_2} - 1 \right) \text{hyp log } r}{1 - \frac{1}{r} \left(\frac{\tau_2}{\tau_1} \right)^{\gamma_{\text{abs}}}} \dots\dots\dots (14.)$$

There may, on the other hand, be a *compressing pump* as well as a *working cylinder*, the air being supplied to the pump at the pressure and volume p_s, v_s ; compressed at the constant absolute temperature τ_2 to the pressure and volume p_a, v_a ; compressed with elevation of temperature to p_a, v_a ; then transferred to the working cylinder, and expanded at the constant absolute temperature τ_1 , to the pressure and volume p_s, v_s ; then expanded with depression of temperature back again to p_s, v_s ; and then discharged. In this case the compressing pump and working cylinder must be of equal size; and the piston of each of them must sweep simply through the maximum volume

$$v_s \dots\dots\dots (15.)$$

per pound of air per stroke, giving for the mean effective pressure

$$\frac{U}{v_s} = p_s \left(\frac{\tau_1}{\tau_2} - 1 \right) \text{hyp log } r \dots\dots\dots (16.)$$

When the engine takes its periodical supply from the external air, p_s is the atmospheric pressure.

It is often convenient to express the *expenditure of heat in foot-pounds per cubic foot swept through*; that is, to state a pressure in pounds on the square foot, which, acting on the piston, would exert energy equivalent to the heat expended. This is given by the formula

$$\frac{H_1}{v_s - v_a} \text{ or } \frac{H_1}{v_s} \dots\dots\dots (17.)$$

as the case may be.

The following is a numerical example:—

DATA.

Ratio of expansion, $r = 2.$

$p_s = 2116.4$ lbs. on the square foot.

Temperatures on the ordinary scale, $T_1 = 650^\circ \text{ F.}$ $T_2 = 150^\circ \text{ F.}$
 Absolute temperatures,..... $\tau_1 = 1111.2$ $\tau_2 = 611.2.$

RESULTS.

$$\left(\frac{r_1}{r_2}\right)^{2.451} = 7.87; \left(\frac{r_2}{r_1}\right)^{2.451} = 0.231 = \frac{1}{4.33}$$

$$v_s = \frac{53.15 r_2}{p_s} = 15.35 \text{ cubic feet per lb.}$$

Then by equation 8—

$$\text{Thermodynamic function } \phi_s - \phi_a = 122.38 \times .30103 = 36.84.$$

By the formula (6)—

$$p_b = 16656; v_b = 3.546.$$

By the formula (7)—

$$p_a = 2 p_b = 33312; v_a = \frac{v_b}{2} = 1.773;$$

$$p_d = 2 p_s = 4232.8; v_d = \frac{v_s}{2} = 7.675;$$

By equations 9, 10, 11—

	Foot-lbs.
$H_1 = \text{heat expended per lb. air per stroke,.....}$	$1111.2 \times 36.84 = 40,937$
$H_2 = \text{heat rejected,.....}$	$611.2 \times 36.84 = 22,517$
$U = \text{energy exerted on piston,....}$	$500 \times 36.84 = 18,420$

By equation 12—

$$\text{Efficiency of fluid.....} = \frac{U}{H_1} = \frac{500}{1111.2} = 0.45$$

For one cylinder acting as compressing pump and working cylinder, by formulæ 13, 14—

Space swept through per lb. air per stroke—

$$v_s - v_a = 13.58 \text{ cubic feet.}$$

Heat expended per cubic foot swept through—

$$\frac{40937}{13.58} = 3014 \text{ lbs. on the square foot.}$$

Mean effective pressure—

$$\frac{18420}{13.58} = 1356 \text{ lbs. on the square foot} = 9.42 \text{ lbs. on the square inch.}$$

For separate compressing pump and working cylinder, by formulæ 15, 16—

Space swept through by each piston per lb. air per stroke—

$$v_s = 15.35 \text{ cubic feet.}$$

Heat expended per cubic foot swept through—

$$\frac{40937}{15.35} = 2666 \text{ lbs. on the square foot.}$$

Mean effective pressure—

$$\frac{18420}{15.35} = 1200 \text{ lbs. on the square foot} = 8.33 \text{ lbs. on the square inch.}$$

This last result illustrates one of the practical difficulties attending the use of air engines in which the changes of temperature are to be effected by means of changes of volume, viz., the smallness of the mean effective pressure compared with the maximum pressure, and the consequent great bulk and strength required for an engine of a given power. In the supposed example, the excess of the maximum pressure, p_m , above that of the atmosphere, is

$$\begin{aligned} 33312 - 2116 &= 31196 \text{ lbs. on the square foot} \\ &= 216.6 \text{ lbs. on the square inch;} \end{aligned}$$

and the strength of the cylinder, and of other parts of the engine, must be adapted to sustain this great pressure, of which the mean effective pressure is only about one twenty-sixth part.

The better to illustrate the bulk required for the engine, on the supposition of there being a separate compressing pump and working cylinder, it may be observed, that the volume to be swept through by the piston in its effective strokes *per minute*, to give *one indicated horse-power*, would be

$$\frac{33000}{1200} = 27\frac{1}{2} \text{ cubic feet.}$$

273. Perfect Air Engines with Regenerators, in General.—Fig. 102, Article 269, may be taken to represent the general case of the diagram of an engine of this class. A B, D C, are portions of two isothermal lines, being common hyperbolas; A D, B C, are portions of a pair of isodiabatic lines, of any figure whatsoever, but connected together by the condition explained in Article 270.

The structure of a regenerator, or heat economizer, has already been explained in Article 268.

The operations undergone by the working mass of air are represented in the diagram as follows:—

C D represents the compression of the air, at the lower limit of absolute temperature τ_2 , the heat produced by the compression being abstracted by a refrigerating apparatus of some kind.

D A represents the series of changes of pressure and volume undergone by the air in passing through the grating or network of the regenerator; which having been previously heated, gives out enough of heat to the air to raise it to the higher limit of absolute temperature τ_1 .

A B represents the expansion of the air at the absolute temperature τ_1 .

B C represents the series of changes of pressure and volume undergone by the air in passing back again through the grating or network of the regenerator, to the material of which apparatus it gives out so much heat as to lower its own absolute temperature back to τ_2 ; and that heat remains stored in the regenerator until employed to raise the temperature of the air at the next stroke.

By thus storing and restoring a certain quantity of heat, the alternate lowering and raising of the temperature of the air is effected without the expenditure for that purpose of any heat from the furnace, except such as is required to supply the waste of heat that occurs in the regenerator; that waste, according to experiment, being from *one-tenth* to *one-twentieth* of the whole quantity of heat required to raise the temperature of the air at each stroke; which quantity of heat, *per pound of air*, has the following value in *foot-pounds*:—

$$130.3 (\tau_1 - \tau_2) \pm \int p \, d v; \dots\dots\dots(1.)$$

in which $\int p \, d v$ denotes the area between one of the isodiabatic lines (as A D), and the ordinates let fall from its ends perpendicular to O X; and that area is to be $\left\{ \begin{array}{c} \text{added} \\ \text{subtracted} \end{array} \right\}$ according as $\left\{ \begin{array}{c} A \\ D \end{array} \right\}$ is the farther from O Y.

(For an *adiabatic* line, the expression 1 becomes = 0).

In the air engines which have been used in practice, the *weight of material in the regenerator appears to have been about forty times the weight of the air passed through it at one stroke.*

The formulæ for the relations amongst the pressures, volumes, and temperatures, for the expenditure of heat in expanding the air, the energy exerted per lb. of air per stroke, and the efficiency, are the same with those in the last Article, except that the ratio,

$$\frac{p_a}{p_d} = \frac{p_b}{p_c} = \frac{\tau_1 \cdot v_d}{\tau_2 \cdot v_a} = \frac{\tau_1 \cdot v_c}{\tau_2 \cdot v_b}, \dots\dots\dots(2.)$$

which in an engine without a regenerator is fixed by equation 4 of
2 A

Article 272, becomes arbitrary in an engine with a regenerator. Hence all the equations of Article 272 hold in the present case, except 4 and its consequences, viz., 5, 6, 13, and 14; instead of which we have simply the relations given in the formula 2 of the present Article.

The volume swept through by the piston per pound of air at each stroke cannot be less than the difference between the greatest and least volumes of the air, and may be greater to an extent depending on the structure and mode of working of the particular engine.

Particular cases of that structure and mode of working will be considered in subsequent Articles; meanwhile the diagrams of energy of two of the more important cases are presented at one view in fig. 103.

In that figure, $A B A' B'$ is the isothermal line of the higher limit of temperature, and $D' C' D C$ that of the lower. $A D, B C,$

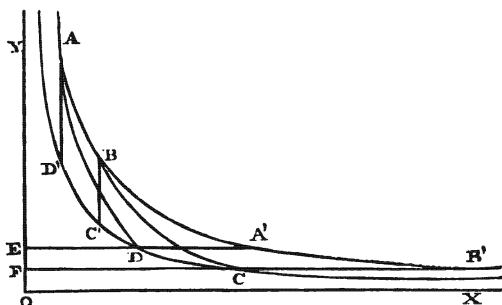

Fig. 103.

are a pair of adiabatic curves, so that $A B C D$ is a diagram for the case already considered in Article 272. $D A', C B'$, are a pair of straight lines, each corresponding to a constant pressure; so that $A' B' C D$ is the diagram of an engine in which the changes of temperature take place at constant pressures. $A D', B C'$, are a pair of straight lines, each corresponding to a constant volume; so that $A B C' D'$ is the diagram of an engine in which the changes of temperature take place at constant volumes.

274. Temperature Changed at Constant Pressure — Ericsson's Engine.—To illustrate the structure of engines whose diagrams approximate more or less closely to $A' B' C D$ in fig. 103, a sketch of the principal parts of Captain Ericsson's air engine (as used about the year 1852) is given in fig. 104, which is a vertical section of a single acting land engine of that kind.

B is the working cylinder, placed over the furnace H . This

cylinder consists of two parts; the upper part, accurately turned, in which the piston works, and the lower part, less accurately made, and of somewhat larger diameter, in which the air receives heat from the furnace.

A is the piston of that cylinder, consisting of two parts. The upper part is accurately fitted, and provided with metallic packing, so as to work air-tight in the upper part of the cylinder. The lower part is made of the same shape with the lower part of the cylinder, but of less dimensions, so as nearly to fit the cylinder, but without touching it. This lower part is hollow, and is filled with brick dust, fragments of fire clay, or some such slow conductor of heat. The object of this is to resist the transmission of heat to the upper parts of the cylinder and piston, and especially to the packing, in order that the bearing surfaces of the cylinder and packing may be kept cool. The cover of the cylinder B has holes in it marked *a*, to admit the external air to the space above the piston.

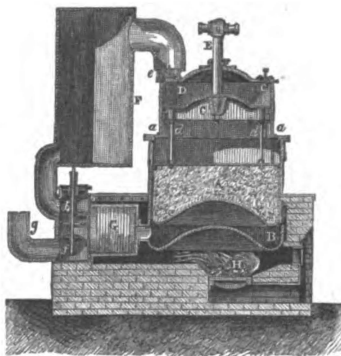

Fig. 104.

D is the compressing pump, being a cylinder standing on the cover of the working cylinder. C is the piston of the compressing pump, connected with the piston A by three or by four piston rods, of which two are shown, and marked *d*. The space below the piston D, and above the piston A, forms one continuous cavity, communicating freely with the external air through the holes *a*. E is the upper piston rod, by which the pistons C and A are connected with the mechanism. That rod traverses a stuffing box in the cover of the compressing pump.

The compression of the air takes place in the upper part of the compressing pump. The air enters through the admission clack *c*, is next compressed, and is then forced through the discharge clack *e* into a receiver or magazine of compressed air, F.

G is the regenerator, being a box containing several layers of wire gauze, which are traversed by the air when it enters and leaves the working cylinder.

b is the induction valve, and *f* the eduction valve, both worked by the mechanism of the engine. When *b* is opened, air is admitted from the receiver F through the regenerator into the cylinder, and lifts the piston A. After a portion of the stroke has been per-

formed, b is shut, and the admission of air cut off; the remainder of the stroke of the piston A is performed by the expansion of the air. During the return stroke, the eduction valve f is kept open, and the air driven out through the regenerator, and through the exhaust pipe g , into the atmosphere.

The ratio of the sizes of the compressing pump, and of the working cylinder, ought to be that of the absolute temperatures of receiving and rejecting heat; that is,

$$\frac{\text{compressing pump}}{\text{working cylinder}} = \frac{\tau_2}{\tau_1} \dots\dots\dots(1.)$$

As the lengths of their strokes are the same, the above ratio is that of the areas of their pistons.

Referring back to fig. 103 in the last Article, the diagram $A' B' C D$ may be taken to represent the action of one lb. of air during one stroke in this engine, when the conditions of maximum efficiency between given limits of temperature are fulfilled. Produce $A' D$ to E , and $B' C$ to F . Then $E D C F$ is the diagram of the compressing pump, and $E A' B' F$ the diagram of the working cylinder. $F C$ represents the admission of the air from the atmosphere into the compressing pump at the atmospheric pressure p_a ; $C D$ its compression in that pump at the constant absolute temperature τ_2 , until its pressure is raised to p_d , the heat produced by the compression being dissipated by conduction, or taken away by some refrigerating apparatus. Owing to the elevation of temperature required in order to cause this heat to be given out as rapidly as it is produced, τ_2 is always higher than the temperature of the external air, but to what extent is uncertain.

$D E$ represents the expulsion of the air from the compressing pump into the receiver.

$E A'$, the admission of the air into the working cylinder, when, by its passage through the regenerator, its absolute temperature is raised to τ_1 , and its volume increased from v_d to v_a .

In order that the operations represented by $D E$ and $E A'$ may be performed without any sensible falling off in the pressure, the engine ought to be *triple*, or still better, *quadruple* (like that which was tried in the steamer "Ericsson"), consisting, in the latter case, of a set of four cylinders, each with its own compressing pump, all driving the same shaft, and communicating with the same receiver, and making their strokes in succession at intervals of a quarter of a revolution. This arrangement is desirable also in order to obtain steady motion.

$A' B'$ represents the expansion of the air in the working cylinder after its admission is cut off, at the constant absolute temperature τ_1 , until the pressure returns to the atmospheric pressure. The heat

required for this expansion is supplied by the furnace through the bottom of the cylinder.

B' F represents the final expulsion of the air, in the course of which it traverses the regenerator in the reverse direction, and transfers to the wire gauze a quantity of heat which is used at the next stroke to raise the temperature of the next mass of air.

The following are the formulæ appropriate to this class of engines:—

DATA.

τ_1 , temperature at which heat is received by the air from the furnace, and the air expanded.

τ_2 , temperature at which the air is compressed, and heat abstracted.

p_0 , atmospheric pressure, if the engine draws its air directly from, and discharges its air directly into the atmosphere, as in the engine just described.

r , ratio of expansion at constant temperature.

RESULTS,

all of which have reference to *one stroke of one pound of air*, pressures in pounds on the square foot, and volumes in cubic feet—

$$\left. \begin{array}{l} \text{Pressures,} \\ p_b = p_c; \\ p_d = p_a = r p_c \end{array} \right\} \dots\dots\dots(2.)$$

$$\left. \begin{array}{l} \text{Volumes,} \\ v_c = \frac{53 \cdot 15 \tau_2}{p_0}; \\ v_b = \frac{\tau_1}{\tau_2} v_c = \frac{53 \cdot 15 \tau_1}{p_0} \\ v_d = \frac{v_c}{r}; v_a = \frac{v_b}{r} = \frac{\tau_1}{\tau_2} v_d. \end{array} \right\} \dots\dots\dots(3.)$$

Thermodynamic function, as in Article 272—

$$\phi_b - \phi_a = 53 \cdot 15 \text{ hyp log } r = 122 \cdot 38 \text{ com log } r \dots\dots(4.)$$

Expenditure of heat in expanding the air, as in Article 272—

$$H_1 = 122 \cdot 38 \tau_1 \text{ com log } r \dots\dots\dots(5.)$$

Heat rejected during the compression of the air—

$$H_2 = 122 \cdot 38 \tau_2 \text{ com log } r \dots\dots\dots(6.)$$

Mechanical energy, as in Article 272—

$$U = 122 \cdot 38 (\tau_1 - \tau_2) \text{ com log } r \dots\dots\dots(7.)$$

Efficiency, supposing no heat wasted, as in Article 272—

$$\frac{U}{H_1} = \frac{\tau_1 - \tau_2}{\tau_1} \dots\dots\dots(8.)$$

Heat stored and restored by regenerator, in foot-lbs.—

$$K_p (\tau_1 - \tau_2) = 183.45 (\tau_1 - \tau_2) \dots\dots\dots(9.)$$

If, according to Mr. Siemens's experiments, *one-twentieth* of this quantity of heat is wasted, the efficiency will be diminished to

$$\frac{U}{H_1 + 9.17 (\tau_1 - \tau_2)} \dots\dots\dots(10.)$$

But from experiments made by Professor Norton on the ship "Ericsson," it seems probable that the waste in the regenerator was more nearly *one-tenth* than one-twentieth of the heat stored; and in that case we have for the diminished efficiency

$$\frac{U}{H_1 + 18.35 (\tau_1 - \tau_2)} \dots\dots\dots(10 A.)$$

Volume swept through by the piston A, per pound of air per stroke—

$$= v_b \dots\dots\dots(11.)$$

Mean effective pressure, per unit of area of the piston A—

$$\frac{U}{v_b} = p_c \cdot \frac{\tau_1 - \tau_2}{\tau_1} \cdot \text{hyp log } r = 2.3026 p_c \cdot \frac{\tau_1 - \tau_2}{\tau_1} \text{ com log } r \dots(12.)$$

Heat expended per cubic foot swept through, not including waste—

$$\frac{H_1}{v_b} = p_c \text{ hyp log } r = 2.3026 p_c \text{ com log } r \dots\dots\dots(13.)$$

The same, with the addition of the supposed waste from the regenerator—

$$\begin{aligned} & \frac{H_1 + m K_p (\tau_1 - \tau_2)}{v_b} \\ & = p_c \left(2.3026 \text{ com log } r + 3.451 m \frac{\tau_1 - \tau_2}{\tau_1} \right) \dots\dots\dots(14.) \end{aligned}$$

m is the fraction which is wasted of the whole heat stored by the regenerator, being from one-tenth to one-twentieth.

In the following numerical example, the proportion of the working cylinder to the compressing pump, $v_b : v_a$, and the ratio of expansion, $v_b : v_a = r$, are those of the air engines of the "Ericsson ;"

but the temperatures of receiving and rejecting heat, and the atmospheric pressure, are merely assumed as probable. The waste of heat in the regenerator is assumed at one-tenth.

DATA.

$$T_2 = 122^\circ; \tau_2 = 583^\circ\cdot 2;$$

$$T_1 = 413^\circ\cdot 6; \tau_1 = 874^\circ\cdot 8;$$

$$p_s = 2116\cdot 4;$$

$$r = 1\cdot 54; \frac{\tau_1}{\tau_2} = 1\cdot 5.$$

RESULTS.

Pressures—

$$p_s = 2116\cdot 4; p_d = p_a = 3259\cdot 3.$$

Volumes—

$$v_s = 14\cdot 65; v_b \text{ (greatest volume)} = 21\cdot 97;$$

$$v_d = 9\cdot 51; v_a = 14\cdot 27.$$

Thermodynamic function—

$$\phi_b - \phi_a = 122\cdot 38 \times 0\cdot 1875 = 22\cdot 95.$$

Latent heat of expansion, $H_1 = 874\cdot 8 \times 22\cdot 95 = 20077$ Foot-lbs.

Heat wasted by regenerator, $\frac{183\cdot 45 \times 291^\circ\cdot 6}{10} = 5349$

Whole heat expended per lb. of air per stroke, 25426

Heat rejected, $H_2 = 583\cdot 2 \times 22\cdot 95$ 13385

Mechanical energy per lb. air per stroke—

$$U = 291^\circ\cdot 6 \times 22\cdot 95 \quad 6692$$

Efficiency of fluid, supposing no heat wasted, $\frac{1}{3}$.

Efficiency of fluid, estimating heat wasted as above—

$$\frac{6692}{25426} = 0\cdot 263.$$

Mean effective pressure—

$$\frac{6692}{21\cdot 97} = 305 \text{ lbs. on the square foot} = 2\cdot 12 \text{ lbs. on the square inch.}$$

The air engines of the "Ericsson" had four working cylinders, each of 14 feet in diameter, so that the joint area of their pistons was

$$154 \times 4 = 616 \text{ square feet.}$$

The length of stroke was 6 feet; the number of revolutions per minute 9; hence, according to the above computation of the mean effective pressure, the energy exerted by the fluid on the piston was

$$305 \times 616 \times 6 \times 9 = 10,145,520 \text{ foot-lbs. per minute;}$$

or 307 indicated horse-power.

In Professor Norton's report, the indicated horse-power of those engines is stated to have been.....	} 300
Difference,.....	7

Volume to be swept through by the working pistons per indicated horse-power—

$$\frac{33000}{307} = 108 \text{ cubic feet per minute;}$$

by the compressing pistons, 72 cubic feet per minute.

These results show the excessive bulk of the air engines of the "Ericsson" in proportion to their power; being the chief obstacle to their use for marine propulsion.

According to Professor Norton, the quantity of fuel (anthracite) consumed in those engines per indicated horse-power per hour, was

$$1.87 \text{ lb.}$$

This gives, for the *duty* of one lb. of anthracite,

$$\frac{1,980,000}{1.87} = 1,059,000 \text{ foot-lbs.}$$

A probable estimate of the theoretical evaporative power of the anthracite used is 14 lbs. of water evaporated from and at 212°, which gives for the mechanical equivalent of the total heat of combustion of 1 lb. of the fuel

$$10,440,000 \text{ foot-lbs.}$$

Hence the *resultant efficiency* of the furnace and fluid appears to have been

$$\frac{1,059,000}{10,440,000} = 0.1014.$$

The probable efficiency of the fluid has already been computed to have been 0.263; hence the probable efficiency of the furnace was

$$\frac{0.1014}{0.263} = 0.4 \text{ nearly;}$$

being about equal to the lowest efficiency of steam boiler furnaces.

The heating surface in the engines of the "Ericsson" consisted simply of the bottoms of the cylinders, and amounted in round numbers to about 700 square feet. The consumption of fuel per hour was 560 lbs. Employing these data in equation 2 of Article 234, and making $B = \frac{1}{4}$, $A = 0.5$ (or taking, in the table of page 295, the efficiency corresponding to $S \div F = 1.25$), we find for the efficiency of a *steam boiler furnace* having the same area of heating surface, and burning fuel at the same rate,

$$0.71.$$

The difference between this and 0.4 must be ascribed to the great inferiority of air to boiling water, as a medium for the *convection of heat*.

It appears from the preceding calculations, that notwithstanding the low efficiency of the furnace in Ericsson's air engine, the efficiency of the fluid was so great as to give a resultant efficiency superior to that of almost all steam engines at the time of the experiments referred to.

The difficulty arising from the great bulk of the engine compared with its power, might be, and probably has been already, obviated to a certain extent, by making the engine draw its supply of air from, and deliver the air from the eduction valve f into, a second receiver containing compressed air at a lower pressure than that of the air in the receiver F . In this case, $p_s = p_a$ would denote the pressure of the air in the second receiver, exceeding the atmospheric pressure in an arbitrary ratio; $p_a = p_s = r p_o$, as before, would denote the pressure in the first receiver F ; and the mean effective pressure would be increased, and the space to be swept through by the piston per horse-power per minute, and consequently the bulk of the engine, would be diminished, in the ratio of p_s to the atmospheric pressure.

The engine, as thus altered, would require to be provided with a small compressing feed pump, to draw from the atmosphere and force into the second receiver enough of air to supply the loss by leakage.

A refrigerator, consisting of tubes with a current of cold water forced through them, or other suitable apparatus, would be needed, in order to abstract from the air passing from the regenerator to the second receiver, the heat which the regenerator fails to abstract from it, by reason of the imperfection of its action; being in fact, the waste heat of the regenerator already referred to.

It might also be necessary to surround the compressing pump D with a casing containing a current of cold water, to abstract the heat produced by the compression of the air; because, owing to the diminished size of that cylinder, the abstraction of the heat by means of its contact with the external air might not be sufficiently rapid.

Some means would have to be adopted to augment the heating surface exposed to the furnace by the working cylinder, without inconveniently increasing the space occupied by the engine. A contrivance proposed for that purpose will be described at the end of the next Article.

275. **Temperature Changed at Constant Volume—Stirling's Engine—Napier and Rankine's Air Heater.**—In fig. 103, Article 273, A B C D' represents the diagram of a perfect engine of the class now under consideration. A B represents the expansion of the air at the constant absolute temperature τ_1 ; B C', the lowering temperature of the air by transmission through a regenerator, at the constant volume $v_b = v_c$; C' D', the compression of the air, at the constant absolute temperature τ_2 ; D' A, the raising the temperature of the air, at the constant volume $v_d = v_a$.

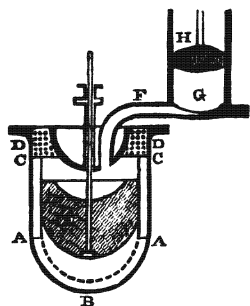

Fig. 105.

of air is kept constantly confined within an enclosed space of variable volume: an arrangement favourable to compactness, as the air can be used at any pressure consistent with safety. To show the general nature of the apparatus by means of which the air is so treated, fig. 105 is a vertical section of the principal parts of the air engine invented by Dr. Robert Stirling, and improved by Mr. James Stirling. D C A B A C D is the air receiver, or heating and cooling vessel; G is the cylinder, with its piston H. The receiver and cylinder communicate freely through the nozzle F, which is at all times open while the engine works.

Within the receiver is an inner receiver or lining of a similar figure, so far as it extends, viz., from B to C C. The hemispherical bottom of this lining is pierced with many small holes, and the space between it and the bottom of the outer receiver is vacant. From A A up to C C, the annular space between the outer receiver and its lining contains the regenerator; being a grating composed of a series of thin vertical oblong strips of metal or glass, with

$$= \frac{v_c}{r}.$$

This mode of regulating the operations undergone by the air is suitable for an engine in which the same individual mass

narrow passages between them. The inner surface of the cylindrical part of the lining, from A A up to C C, is turned, and the plunger E moves vertically up and down within it, fitting easily, so as to leave the least space possible without causing perceptible friction. This plunger is hollow, and filled with brick dust, or some such slow conductor of heat.

The space from C C to D D between the barrel of the receiver and the concave part of its cover, and above the upper edge of the lining, contains the "*refrigerator*," which consists of a horizontal coil of fine copper tube, through which a current of cold water is forced by a pump, not shown in the figure.

There is an air compressing pump, not shown, which forces into the nozzle F enough of air to supply the loss by leakage.

The hemispherical bottom A B A of the receiver forms the heating surface which is exposed to the furnace.

The effect of the alternate motion of the plunger E up and down is to transfer a certain mass of air, which may be called the *working air*, alternately to the upper and lower end of the receiver, by making it pass up and down through the regenerator between A A and C C. The perforated hemispherical lining of the bottom of the receiver causes a diffusion and rapid circulation of the air as it passes into the lower end of the receiver, and thus facilitates the convection of heat to it, for the purpose of enabling it to undergo the expansion represented by A B in fig. 103; during which expansion it lifts the piston H. The descent of the plunger causes the air to return through the regenerator to the upper end of the receiver. It leaves the greater part of the heat corresponding to the range of temperature $\tau_1 - \tau_2$ stored in the plates of the regenerator. The remainder of that heat (being the heat wasted by the imperfect action of the regenerator) is abstracted by the refrigerator, which also abstracts the heat produced by the compression of the air when the piston H descends. The heat stored in the regenerator serves to raise the temperature of the air, when, by the lifting of the plunger E, it is sent back to the lower end of the receiver.

The mechanism for moving the plunger E is so adjusted, that the up stroke of that plunger takes place when the piston H is at or near the beginning of its forward stroke, and the down stroke of the plunger when the piston H is at or near the beginning of its back stroke.

The diagram represents a single acting engine. In a double acting engine, the other end of the cylinder G is connected with another air receiver similar to that shown, and the plungers of the two receivers are made to move in opposite directions to each other.

Besides the *working air*, there is obviously a mass of air which does not pass up and down through the regenerator, but merely

passes into and out of the cylinder G and nozzle F. This mass of air remains always nearly at the lower absolute temperature τ_2 , and is not the means of transforming heat to mechanical energy, but merely of transmitting pressure and motion between the working air and the piston. The piston and cylinder being always cool, can be lubricated with oil without the risk of decomposing it; and the piston rod can be made to work through a leather collar. (For details respecting this engine, see *Proceedings of the Institution of Civil Engineers*, 1854.)

The general theory of the action of a mass of elastic fluid in a heat engine as a *cushion* between the working fluid and the piston, has already been given in Article 262. The application of that theory to the present case is shown in fig. 106.

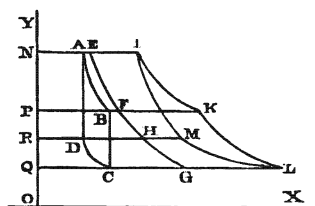

Fig. 106.

Let $A B C D$ be the real diagram of one lb. of the working mass of air, so that $P \bar{B} = Q \bar{C} = v_s = v_r$, represents its greatest volume in cubic feet per lb. This represents the space below the plunger of the receiver when it is at the top of its stroke. Add a space equal to the volume of the air contained in the port F, in the clearance below the piston H, in the spaces between the coils of the refrigerating tube, and in those of the upper half of the regenerator; the sum will be the whole space filled with air when the piston H is at the end of its back stroke and beginning of its forward stroke. Through A draw $N \bar{I}$ parallel to $O X$ to represent that space; then $A \bar{I}$ represents the volume of the cushion air when it is under the greatest pressure. Make $N \bar{E} = A \bar{I}$, and make $E F H G$ an isothermal curve; that is, a common hyperbola, the product of whose rectangular co-ordinates $O \bar{N} \times N \bar{E}$, $O \bar{P} \times P \bar{F}$, &c., is constant. Draw $P \bar{B} F$, $R \bar{D} H$, $Q \bar{C} G$, parallel to $O X$, and make $B \bar{K} = P \bar{F}$, $D \bar{M} = R \bar{H}$, $C \bar{L} = Q \bar{G}$; then K, L, M, and the point I formerly found, will be the corners of the *actual diagram* of the cylinder; and any number of intermediate points in that diagram can be found in a similar manner. The *volume to be swept through by the piston per pound of air per stroke* is represented by

$$\overline{Q L} - \overline{N I}.$$

The ratio of the weight of the cushion air to the weight of the working air, being that of the volumes of those masses of air at the same temperature, is

$$\overline{Q G} \div \overline{Q C}.$$

The algebraical expression of these principles will be given after the formulæ relating to the efficiency of the fluid.

The actual indicator diagram described by Stirling's air engine was an oval, resembling the figure I K L M with the corners rounded off. This must be ascribed partly to the fact, that the operations actually performed on the working air, are only approximately represented by the figure A B C D, the heating and cooling not taking place exactly at constant volumes, nor the expansion and compression exactly at constant temperatures, and partly to the inertia of the piston and other moving parts of the indicator.

The following are the formulæ appropriate to the class of engine now under consideration:—

DATA.

τ_1 , absolute temperature of receiving heat, and expanding the working air.

τ_2 , absolute temperature of compressing the working air, and rejecting heat.

p_a , greatest pressure.

r , ratio of expansion.

q , ratio of volume of clearance and passages to greatest volume of working air.

$$\text{In fig. 106, } \frac{\overline{N I}}{\overline{Q C}} = 1 + q.$$

RESULTS,

per lb. of working air per stroke—

$$\left. \begin{aligned} \text{Pressures—} & & p_b = \frac{p_a}{r}; \\ & & p_c = \frac{p_a}{r} \cdot \frac{\tau_2}{\tau_1}; \quad p_d = p_a \cdot \frac{\tau_2}{\tau_1}. \end{aligned} \right\} \dots\dots\dots(1.)$$

Volumes of one lb. of working air—

$$v_a = v_d = \frac{53 \cdot 15 \tau_1}{p_a}; \quad v_b = v_c = r v_a \dots\dots\dots(2.)$$

Thermodynamic function—

$$\phi_c - \phi_a = 53 \cdot 15 \text{ hyp log } r = 122 \cdot 38 \text{ com log } r \dots\dots(3.)$$

Expenditure of heat in expanding the air—

$$H_1 = 122 \cdot 38 \tau_1 \text{ com log } r \dots\dots\dots(4.)$$

Waste heat of regenerator—

$$m K_v (\tau_1 - \tau_2) \dots \dots \dots (5.)$$

($m = \text{from } \frac{1}{16} \text{ to } \frac{1}{32} ? K_v = 130.3$).

Heat rejected during the compression of the air—

$$H_2 = 122.38 \cdot \tau_2 \cdot \text{com log } r \dots \dots \dots (6.)$$

Mechanical energy—

$$U = 122.38 (\tau_1 - \tau_2) \text{com log } r \dots \dots \dots (7.)$$

Efficiency, if $m = \frac{1}{16}$ nearly—

$$\frac{U}{H_1 + 13 (\tau_1 - \tau_2)} \dots \dots \dots (8.)$$

The following formulæ have reference to the volume of the cushion air, and of the whole air, working air and cushion air together, *per lb. of working air*; and the small letters affixed to the letter v refer to the points marked with the corresponding capital letters in fig. 106:—

Least total volume of air—

$$v_i = (1 + q) v_o \dots \dots \dots (9.)$$

Volumes of cushion air—

$$\left. \begin{aligned} v_o &= v_i - v_a = v_o \{ (1 + q) r - 1 \}; \\ v_f &= r v_o; \\ v_h &= \frac{v_g}{r}; v_g = r \frac{\tau_1}{\tau_2} v_o = \frac{\tau_1}{\tau_2} v_o \{ (1 + q) r - 1 \}. \end{aligned} \right\} \dots \dots (10.)$$

Total volumes—

$$\left. \begin{aligned} v_h &= v_o + v_f; v_m = v_d + v_h; \\ v_i &= v_o + v_g \\ &= v_o \left\{ (1 + q) r \cdot \frac{\tau_1}{\tau_2} - \frac{\tau_1}{\tau_2} + 1 \right\}. \end{aligned} \right\} \dots \dots \dots (11.)$$

Ratio of cushion air to working air—

$$\frac{v_g}{v_o} = \frac{\tau_1}{\tau_2} \{ (1 + q) r - 1 \} \dots \dots \dots (12.)$$

Volume swept through by the piston per lb. of air per stroke—

$$v_i - v_i = v_o \left\{ (r-1) \frac{\tau_1}{\tau_2} + q \left(r \frac{\tau_1}{\tau_2} - 1 \right) \right\} \dots\dots (13.)$$

Mean effective pressure—

$$\frac{U}{v_i - v_i} \dots\dots\dots (14.)$$

The quantities taken as *data* in the preceding set of formulæ are those which would probably be given for a proposed engine. In the case of an existing engine, and sometimes in the case of a proposed engine also, the ratio of expansion r may at first be unknown; and instead of it these may be given, the proportion of the space swept through by the piston to the space swept through by the plunger, viz.,

$$\frac{v_i - v_i}{v_o}$$

In this case, the following formula, deduced from equation 13, serves to determine the ratio of expansion:—

$$r = \frac{1}{1+q} \left\{ \frac{\tau_2}{\tau_1} \left(\frac{v_i - v_i}{v_o} + q \right) + 1 \right\}; \dots\dots\dots (15.)$$

which having been found, all the formulæ can be used as already given.

In the following numerical example, the data are taken from the account by Mr. James Stirling, in the *Proceedings of the Institution of Civil Engineers*, for 1845, of an air engine which worked for several years at the Dundee foundry:—

DATA.

$$T_1 = 650^\circ; \tau_1 = 1111 \cdot 2.$$

$$T_2 = 150^\circ; \tau_2 = 611 \cdot 2.$$

$$p_a = 240 \times 144 = 34,560.$$

q , roughly estimated at 0.05.

$$\frac{v_i - v_i}{v_o} = \frac{1}{2}.$$

RESULTS.

$$r = \frac{1}{1.05} \left\{ 0.55 (0.5 + 0.05) + 1 \right\} = 1.24.$$

$$p_b = 27870; p_c = 15330; p_d = 19000.$$

$$v_a = v_d = 1.709; v_b = v_c = 2.119.$$

$$\phi_b - \phi_a = 122.38 \times 0.09517 = 11.647.$$

Latent heat of expansion, $H_1 = 11.647 \times 1111.2 = 12942$

Waste heat of regenerator, $13 \times 500 = 6500$

Whole heat expended per lb. of air per stroke, 19442

Rejected heat, $H_2 = 11.647 \times 611.2$ 7119

Mechanical energy per lb. air per stroke—

$$U = 11.647 \times 500 = 5823$$

Efficiency of fluid— $\frac{5823}{19443} = 0.3.$

Volume swept by piston per lb. of air per stroke—

$$v_i - v_i = 2.119 \div 2 = 1.06 \text{ cubic feet.}$$

Mean effective pressure—

$$\frac{U}{v_i - v_i} = \frac{5823}{1.06} = 5437 \text{ lbs. on the square foot}$$

$$= 37.75 \text{ lbs. on the square inch.}$$

The engine to which these calculations refer was double acting, with a cylinder of 16 inches diameter, and 4 feet length of stroke, making 28 revolutions per minute.

Hence, area of piston = 200 square inches; and

Energy exerted by air on piston per minute, as found by calculation—

$$= 37.75 \times 200 \times 4 \times 28 \times 2 = 1,691,200 \text{ foot-lbs.}$$

The work actually performed against a friction brake dynamometer per minute was, 1,500,000

And the work performed against the friction of the engine when unloaded, having been found to be one-ninth of the useful work, or, 166,667

The energy exerted by the air on the piston per minute is found from the experiments to have been, 1,666,667

The difference between theory and experiment, ... 24,533
is practically unimportant.

The work expended on the friction of the engine is estimated at one-tenth of the whole energy exerted by the air; because it was found that when the receivers were charged with air at about one-tenth of the ordinary working density, the power of the engine was just sufficient to enable it to move unloaded.

The following is a comparison between theory and experiment, as to the quantity of heat abstracted by the refrigerating apparatus:—

By theory, the efficiency of the fluid in the engine is found to have been 0.3; that is, three-tenths of the whole heat received by the fluid were converted into mechanical energy, leaving seven-tenths to be abstracted by the refrigerator. Therefore, the heat abstracted by the refrigerator exceeded the heat converted into mechanical energy in the ratio of 7 to 3. The mechanical energy exerted by the fluid was 1,691,200 foot-lbs. per minute. Therefore the heat abstracted by the refrigerator per minute was

$$1,691,200 \times \frac{7}{3} = 3,946,000 \text{ foot-lbs.}$$

Mr. Stirling states, that the quantity of water passed through the refrigerator was 4 cubic feet; that is, 250 lbs. per minute, and that its temperature was raised from 16° to 18° by the heat which it abstracted. Take 17° as the average elevation of its temperature; then, as the dynamical specific heat of water is 772 foot-lbs., we have, for the heat abstracted by this quantity of water, $250 \times 17 \times 772 = 3,281,000$ „

Difference..... 665,000

or about one-sixth of the greater quantity.

This difference may be partly accounted for by the fact, that part of the heat abstracted from the working air must have been conducted through the covers and the upper portions of the sides of the receivers to the external air, without affecting the water in the coils of tube. It is possible, also, that the waste of heat through imperfect action of the regenerator may have been over-estimated in the theoretical calculation.

The energy exerted by the fluid in an hour was

$$1,666,667 \times 60 = 100,000,000 \text{ foot-lbs.}$$

The fuel consumed in 12 hours was 1000 lbs., or 83.3 lbs. per hour, so that the *indicated duty* of one lb. of coal was

$$\frac{100,000,000}{83.3} = 1,200,000 \text{ foot-lbs.}$$

Mr. Stirling considers the coal employed to have been of about *three-fourths* of the evaporative power of Newcastle coal. Assuming, therefore, the total heat of combustion of one lb. of the coal to have been

$$9,000,000 \text{ foot-lbs.,}$$

we find for the *resultant efficiency* of the furnace and fluid,

$$\frac{1,200,000}{9,000,000} = 0.133.$$

The efficiency of the fluid having been 0.3, it appears that the *efficiency of the furnace* was

$$\frac{0.133}{0.3} = 0.44,$$

The heating surface was about 75 square feet. In a steam boiler furnace, burning the same quantity of fuel, this would have given an efficiency of about

$$0.61.$$

In Stirling's engine, therefore, the efficiency of the furnace approached more nearly to that of a steam boiler furnace, than in Ericsson's engine, owing probably to the greater density of the air, and its more rapid circulation over the bottom of the receiver.

With a view to increasing the efficiency of air engines by obtaining an extensive heating surface, without inconveniently enlarging their bulk, Mr. James R. Napier, and the Author of this work, have proposed the heating apparatus shown in fig. 107. That figure represents the bottom of a cylindrical air receiver, consisting of a flat tube-plate, from which several tubes, open at the upper end, and closed at the lower end, descend into a flame chamber. P is the lower end of a plunger,

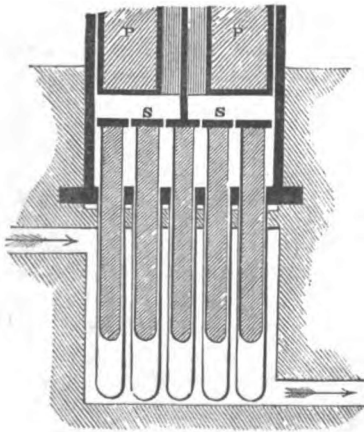

Fig. 107.

descend into a flame chamber. P is the lower end of a plunger,

corresponding to that marked E in fig. 105. In fig. 107, the regenerator occupies a cylindrical hole in the centre of that plunger; but it might, if convenient, occupy an annular space surrounding the plunger, as in fig. 105.

S is a second, or lower plunger, consisting of a perforated plate, from which cylindrical rods descend into the tubes, and nearly fit them. When the lower plunger is depressed, the rods nearly fill the tubes, and the heat transmitted from the furnace accumulates in the metal of the tubes and rods. When the lower plunger is raised, part of the air descends into the tubes, and is heated by contact with them and with the rods, and part remains in the large cylindrical part of the receiver, and is heated by contact with the upper ends of the rods. This apparatus has been found to heat the air rapidly; but its efficiency has not yet been ascertained by any exact experiment.

276. Heat Received and Rejected at Constant Pressures—Joule's Engine.—In a paper by Mr. Joule, with a supplement by Professor William Thomson, in the *Philosophical Transactions* for 1851, it is proposed to use an air engine in which the regenerator and refrigerator are dispensed with; so that the air shall receive and reject heat, not at a pair of constant temperatures, but at a pair of constant pressures.

This proposed engine would consist essentially of three parts—a compressing pump, a heating vessel (being a set of tubes traversing a furnace), and a working cylinder. The compressing pump and working cylinder would be clothed with non-conducting materials.

The compressing pump would draw air from the atmosphere, compress it in a certain proportion, and force it into one end of the heating vessel, at a temperature elevated above the atmospheric temperature to an extent corresponding to the compression. In the heating vessel, the air would have its temperature further raised, and its volume expanded, at constant pressure, by the heat received from the furnace. From the farther end of the heating vessel, the air would pass through an induction valve into the working cylinder, driving the piston through a certain part of a stroke. The valve being closed, and the admission of air cut off, the piston would be driven through the remainder of its stroke by the expansion of the air down to the atmospheric pressure; and during that expansion, the temperature would fall to a certain extent. The air would then be discharged into the atmosphere at a temperature exceeding the atmospheric temperature, the heat due to the excess of temperature being rejected along with the air.

In fig. 108, A B C D A represents the diagram of energy of such

an engine, being found by taking away $E A D F E$, the diagram of the compressing pump, from $E B C F E$, the diagram of the working cylinder.

The straight line $F D$ represents the volume v_a of one lb. of air, drawn from the atmosphere, at the atmospheric pressure p_a , and absolute temperature τ_a .

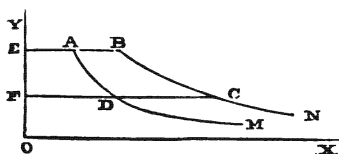

Fig. 108.

$D A$, a portion of an adiabatic curve, represents the compression of that air, until it attains the pressure, volume, and temperature, p_a, v_a, τ_a .

The straight line $E A$ represents the volume v_a of the compressed air, as forced into the heating vessel.

The straight line $E B$ represents the volume v_b of that air after it has traversed the heating vessel, and as it enters the working cylinder under the constant pressure p_a , and at the highest absolute temperature τ_b .

$B C$, a portion of an adiabatic curve, meeting the straight line $F D C$ in C , represents the expansion of the air to the volume v_c , at which it returns to the atmospheric pressure $p_c = p_a$, and falls to a certain temperature τ_c .

$C F$ represents v_c , the volume of the air when finally expelled into the atmosphere.

The heat received by each pound of air is represented by the area between $A B$, and the indefinitely prolonged adiabatic curves $A D M, B C N$.

The heat rejected with each pound of the air when discharged is represented by the area between $D C$ and the curves $D M, C N$.

The energy exerted by each pound of air is represented by the area $A B C D$.

The volume swept through by the piston of the working cylinder per pound of air is $\overline{F C} = v_c$; the volume swept through by the piston of the pump is $\overline{F D} = v_a$.

The following are the formulæ proper to this kind of engine:—

DATA.

- Atmospheric pressure and absolute temperature, p_a, τ_a
- Ratio of compression and expansion, r .
- Highest absolute temperature, τ_b .

RESULTS,

per pound of air.

Absolute temperatures—

$$\tau_a = \tau_d r^\gamma - 1 = \tau_d r^{0.408}; \tau_c = \frac{\tau_b}{r^{0.408}} \dots \dots \dots (1.)$$

Pressures—

$$p_a = p_b = p_d r^\gamma = p_d r^{1.408}; p_c = p_d \dots \dots \dots (2.)$$

Volumes—

$$\left. \begin{aligned} v_d &= \frac{53.15 \tau_d}{p_d}; \\ v_a &= \frac{v_d}{r}; v_b = v_a \cdot \frac{\tau_b}{\tau_a} = v_d \cdot \frac{\tau_b}{\tau_d r^{1.408}}; \\ v_c &= r v_b = v_d \cdot \frac{\tau_b}{\tau_d r^{0.408}}. \end{aligned} \right\} \dots \dots \dots (3.)$$

Heat received—

$$H_1 = 183.45 (\tau_b - \tau_a) = 183.45 (\tau_b - \tau_d r^{0.408}) \dots \dots \dots (4.)$$

Heat rejected—

$$H_2 = 183.45 (\tau_c - \tau_d) = 183.45 \left(\frac{\tau_b}{r^{0.408}} - \tau_d \right) = \frac{H_1}{r^{0.408}} \dots \dots (5.)$$

Energy exerted—

$$\begin{aligned} U = H_1 - H_2 &= 183.45 \left\{ \tau_b \left(1 - \frac{1}{r^{0.408}} \right) - \tau_d \left(r^{0.408} - 1 \right) \right\} \\ &= H_1 \left(1 - \frac{1}{r^{0.408}} \right); \dots \dots \dots (6.) \end{aligned}$$

Efficiency of fluid—

$$\frac{U}{H_1} = \frac{\tau_a - \tau_d}{\tau_a} = \frac{\tau_b - \tau_d}{\tau_b} = 1 - \frac{1}{r^{0.408}} \dots \dots \dots (7.)$$

Mean effective pressure—

$$\frac{U}{v_c} = 3.451 p_d \left(r^{0.408} - 1 \right) \left(1 - \frac{\tau_d}{\tau_b} \cdot r^{0.408} \right) \dots \dots \dots (8.)$$

The following is a numerical example, which, however, is imaginary, as no experiments have been made on engines of the kind now considered:—

DATA.

$$p_a = 2116.4; T_a = 50^\circ \therefore r_a = 511^\circ.2;$$

$$r = 2;$$

$$T_b = 561^\circ.2 \therefore r_b = 1022^\circ.4.$$

RESULTS.

$$r^{0.408} = 1.327; \frac{1}{r^{0.408}} = 0.7537; \frac{r_a}{r_b} = \frac{1}{2}.$$

$$r_a = 678^\circ.4 \therefore T_a = 217^\circ.2; r_s = 770.6 \therefore T_s = 309^\circ.4.$$

$$p_a = p_b = 2.654 \times 2116.4 = 5617; p_s = p_d = 2116.4.$$

$$v_a = 12.84; v_s = 6.42; v_b = 9.68; v_d = 19.35;$$

$$H_1 = 183.45 \times 344^\circ = 63107$$

$$H_2 = 183.45 \times 259.4 = 47587$$

$$U = 183.45 \times 84.6 \quad \overline{15520}$$

$$\text{Efficiency of fluid, } \frac{15520}{63107} = 0.246.$$

Mean effective pressure—

$$\frac{15520}{19.35} = 802 \text{ lbs. on the square foot} = 5.57 \text{ lbs. on the square inch.}$$

If an engine of this class were made to work up to a high temperature, it would be necessary to keep the packing of the piston cool by some such means as making the lower part of the piston, as in Ericsson's engine, hang considerably below the packing ring, its interior being hollow, and filled with a slowly conducting material.

277. **Furnace-Gas Engines — Cayley's — Gordon's — Avenier de la Grevé's.**—The greater part of the waste of heat from the furnace might be prevented if it were practicable to drive the piston of an engine directly by means of the hot gaseous products of combustion. An engine of this kind was made and worked experimentally by Sir George Cayley. It consists essentially of the same parts with the air engine described in the preceding Article, except that in the furnace gas engine, the heating vessel and the furnace are one; that is to say, the compressing pump draws air from the atmosphere, compresses it, and forces it into a strong air-tight

furnace, where its oxygen combines with the fuel; then the mixed hot gas produced by the combustion is admitted into the working cylinder, where it drives the piston through part of its stroke at full pressure, and through the remainder by expansion, until it falls to the atmospheric pressure, and is discharged. The furnace is fed through a double valve, which is so constructed, that fuel can be introduced through it without permitting the escape of more than a very small quantity of the compressed air.

The theoretical diagram of such an engine, and the formulæ applicable to it, are exactly similar to those given in Article 276, except that the furnace gas is somewhat denser than air. This difference may be allowed for by conceiving, that all the formulæ, instead of having reference to *one pound* of the gas, have reference to *so much of the gas as is produced by supplying one pound of air to the furnace.*

The cylinder, piston, and valves of this engine, were found to be so rapidly destroyed by the intense heat, and the dust from the fuel, that no attempt was made to bring it into general practical use.

An engine on nearly the same principle was invented by Mr. Alexander Gordon.

Dr. Avenier de la Grée has proposed a kind of furnace-gas engine in which, so far as it can be judged of by mere description, without experiment, the difficulties arising from the dust and heat may very probably be overcome; and the only objection will be that common to all air engines which draw a cylinderful of air from the atmosphere at each stroke, viz, the greatness of their bulk in proportion to their power; but it would be unjustifiable to publish any details respecting this invention, until after the inventor shall himself have published an account of it.

SECTION 5.—*Of the Efficiency of the Fluid in Steam Engines.*

278. **Theoretical Diagrams of Steam Engines in General.**—The sketches which have already been given in fig. 17, page 48, and in fig. 99, page 337, illustrate the general character of the diagrams which indicate the energy exerted by the steam in the cylinders of steam engines.

The curves actually described on the indicator cards of these engines present so many differences as to the mode in which the pressure and volume of the steam vary during its action on the piston, that their figures cannot be expressed *exactly* by any general system of mathematical formulæ; especially because in the present state of our knowledge, it is impossible accurately to separate those irregularities in diagrams which arise from real fluctuations in the pressure of the steam, from those which arise from the friction and

inertia of the moving parts of the indicator. Some of those irregularities will be more particularly described in a subsequent Article.

In order that it may be possible to compute from theoretical principles the power and efficiency of the fluid in steam engines, a figure is *assumed* for the diagram, approximating to the real figure, but more simple (see fig. 109). In that figure, $\overline{A B}$ represents the volume of a certain mass of steam, when admitted into the cylinder, so as to drive the piston through a space equal to that volume. The *first assumption* by which the diagram is simplified is, that the pressure of the steam remains constant during its admission, so that $A B$ is a straight line parallel to $O X$, and the constant pressure is represented by $\overline{O A} = \overline{G B}$.

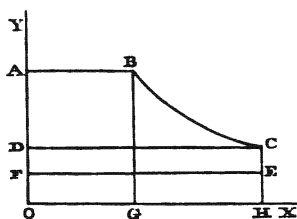

Fig. 109.

The curve $B C$ represents the expansion of the steam after its admission is cut off. In actual diagrams, this curve presents a great variety of figures, depending upon the communication of heat to and from the steam, and other causes, and almost always contains undulations, which

probably arise partly from vibrations in the mass of steam itself, and partly from oscillations due to the inertia of the indicator piston. The *second assumption* consists in assigning to the curve $B C$ one or other of two definite figures, according to the following suppositions:—

I. When the cylinder is either exposed, or simply cased in slowly conducting materials, such as felt and wood, the steam is assumed to expand without receiving or giving out heat; so that $B C$ is an *adiabatic curve*, whose form will be explained in Article 281.

II. When between the slow conducting casing and the cylinder, there is an iron casing or outer cylinder called the "steam jacket," supplied with steam from the boiler, it is assumed, that the heat communicated by means of that jacket to the steam expanding in the cylinder, is just sufficient to prevent any practically appreciable part of it from becoming liquid; so that $B C$ is part of a curve whose co-ordinates represent the pressures and the volumes of a given weight of steam of saturation.

These two suppositions have reference to engines in which the steam is not "superheated;" that is, raised to a temperature above the boiling point corresponding to its pressure. The action of superheated steam will be considered in the next section.

The *third assumption* is, that the steam is exhausted, or discharged from the cylinder during the return stroke, at a constant pressure; so that the lower side EF of the diagram is a straight line parallel to OX ; and the constant *back pressure* is represented by $\overline{OF} = \overline{HE}$, which may be equal to, or less than the pressure at the end of the expansion \overline{HC} . (It would be possible, also, to make the back pressure *greater* than the pressure at the end of the expansion; but this never occurs in engines that are well constructed and worked.) The third assumption involves also the assumption, that the fall of pressure, if any, at the end of the stroke (represented by \overline{CE}), takes place suddenly.

The value taken for the assumed constant back pressure ought of course to be equal to the *mean* value of the actual variable back pressure, so far as it can be accurately ascertained. What that mean value is in different cases will be considered in a special Article.

The *fourth assumption* consists in neglecting the volume of the liquid water as compared with that of the steam, so that the side FDA of the diagram is a straight line coinciding with OY , instead of being a curve having ordinates parallel to OX , representing the successive volumes of the water as it sustains a gradually increasing pressure in the feed pump, and corresponding (though of much smaller magnitude) to the ordinates parallel to OX of the curves marked DA in figs. 104, Article 274, and 108, Article 277. This assumption gives rise to no error appreciable in practice.

Thus is obtained a diagram for purposes of calculation, of the kind of form represented by $ABCEFDA$, of which the side BC alone is curved. Experience proves, that although in a diagram of this kind, in which the smaller fluctuations of the pressure are neglected, *the pressures corresponding to particular positions of the piston* sometimes differ considerably from the actual pressures, yet the differences, being in opposite directions at different points of the diagram, *neutralize each other* in such a manner, that the agreement between calculation and experiment is very close as regards the *energy exerted*, and the *mean effective pressure*; being the quantities which are of the greatest importance in practice.

For the present, the quantity of steam acting as a *cushion* (Article 262) is supposed either to be inappreciably small, or to have had its successive volumes calculated and deducted, so that the diagram in fig. 109 is freed from its effects. The effect of "cushioning" steam will be considered farther on.

279. **Forms of Expression for Energy.**—The following notation will be employed in formulæ relating to the efficiency of steam:—

Quantity.	Symbol.	Represented in the diagram by
<i>Absolute pressures of steam—</i>		
During the admission,	p_1	$\overline{O A} = \overline{C B}$
At any time during the expansion,	p	ordinate of B C
At the end of the expansion,	p_2	$\overline{H C} = \overline{O D}$
During the return stroke,	p_3	$\overline{H E} = \overline{O F}$
<i>Absolute temperatures—</i>		
Of the steam when admitted,	τ_1	
Of the steam at any time during the expansion,	}	τ
Of the steam at the end of the expansion,		
Of the feed water supplied to the boiler,	}	τ_4
<i>Temperatures on ordinary scale,</i>	T_1 , &c.	
<i>Volumes of one lb. of steam—</i>		
When admitted,	v_1	
At any time during the expansion,	v	
At the end of the expansion,	v_2	
<i>Density of steam in lbs. per cubic foot—</i>		
When admitted,	D_1	
<i>Volume occupied by the mass of steam, or of steam and liquid water, under consideration—</i>		
When admitted,	u_1	$\overline{A B} = \overline{O G}$
At any time during the expansion,	u	abscissa of B C
At the end of the expansion,	$u_2 = r u_1$	$\overline{D C} = \overline{O H}$
<i>Ratio of expansion,</i>	$r = \frac{u_2}{u_1}$	$\overline{D C} \div \overline{A B}$
<i>Energy exerted by one lb. of steam, ...</i>	U	.
<i>Energy exerted by the mass of steam under consideration,</i>	}	area A B C E F A
<i>Mean effective pressure,</i>	$\frac{U}{v_2} = p_m - p_3$	$\frac{\text{area A B C E F A}}{O H}$

$\frac{1}{r}$, the reciprocal of the ratio of expansion, is called the *admission*, and sometimes the *cut off*, being the fraction of the stroke at which the admission of steam is cut off.

The reason for having the symbol u_1 distinct from v_1 , to denote the volume of the mass of steam when admitted, is that it is in

some cases more convenient to consider the action of a *pound* of steam (in which case $u_1 = v_1$), while in other cases it is more convenient to consider the action of so much steam as occupies a cubic foot when first admitted (in which case $u_1 = 1$); or rather, to speak strictly, so much steam as occupies, when first admitted, one cubic foot more than it did in the liquid state; but the difference between these two definitions of the mass of steam under consideration is neglected.

The relations between τ ($= T + 461\cdot2$ Fahrenheit) p , v , and D , are given by the formulæ of Article 206, equations 1 and 2 (page 237), and of Article 256, equation 1 (page 326), and by Tables IV. and VI. (As to the interpolation of quantities in these tables, see Article 279 A, immediately following the present Article.)

There are two modes of expressing and calculating the energy represented by the area of the diagram. The first, which corresponds to that expressed for diagrams in general by equation 2 of Article 263, is the best suited for purposes of exact calculation, and of reasoning about principles; the second, which corresponds to the expression in equation 1 of the same Article, is the best suited to a certain approximate method of calculation, which is expeditious and convenient in practice.

METHOD I.—

To the area A B C D,.....	$\int_{p_2}^{p_1} u \, dp$
Add the rectangle $\overline{D F} \times \overline{C D}$,.....	$+ u_2 (p_2 - p_3)$
Then the area A B C E F A = $\frac{u_1}{v_1} U = \int_{p_2}^{p_1} u \, dp + u_2 (p_2 - p_3)$ (1.)	

The integral in this expression, as will afterwards be shown, is calculable by the aid of certain functions of the absolute temperatures τ_1, τ_2 .

METHOD II.—

To the rectangle $\overline{O A} \times \overline{A B}$,.....	$p_1 u_1$
Add the area G B C H,.....	$+ \int_{u_1}^{u_2} p \, du$
And subtract the rectangle $\overline{O F} \times \overline{F E}$	$- p_3 u_2$
Then the area A B C E F A = $\frac{u_1}{v_1} U = p_1 u_1 + \int_{u_1}^{u_2} p \, du - p_3 u_2$. (2.)	

According to this form of expression, the mean effective pressure has the value

$$\frac{U}{v_2} = \frac{u_1 U}{v_1 u_2} = \frac{p_1 u_1 + \int_{u_1}^{u_2} p du}{u_2} - p_2 = p_m - p_2; \dots (3.)$$

in which the symbol p_m denotes the *mean gross pressure*, or *mean forward pressure*, which is represented in the diagram by the mean height of the line A B C above O X.

The convenience of this second method arises from the fact, that within the limits of pressure and volume which usually occur in practice, the curve B C approximates to a curve of the *hyperbolic class*; that is, a curve in which the ordinate is inversely proportional to some power of the abscissa, as expressed by the equation

$$p \propto u^{-i}; \dots (4.)$$

i being an index which is different according to the circumstances of the case, and is to be found by trial. When $i = 1$, the curve is a common hyperbola, and the area O A B C H is

$$p_1 u_1 + \int_{u_1}^{u_2} p du = p_1 u_1 \cdot (1 + \text{hyp log } r); \dots (5.)$$

but in the cases which occur in the working of saturated steam, i is fractional, and greater than 1; and then we have

$$\begin{aligned} p_1 u_1 + \int_{u_1}^{u_2} p du &= p_1 u_1 + \frac{p_1 u_1 - p_2 u_2}{i-1} \\ &= p_1 u_1 \left(\frac{i}{i-1} - \frac{1}{i-1} \cdot r^{-i+1} \right) = p_m r u_1; \dots (6.) \end{aligned}$$

from which is obtained the following expression for the *mean forward or gross pressure*:—

$$p_m = p_1 \cdot \frac{i r^{-1} - r^{-i}}{i-1} \dots (7.)$$

Formulae of this kind, and tables computed by means of them, such as Tables VII. and VIII. at the end of the volume, are convenient in approximate calculations for practical purposes, especially as they do not involve the temperature.

279 A. **Interpolation of Quantities in the Tables.**—When in using Table IV. or Table VI. for steam, or Table V. for æther, it is required to find some quantity intermediate between those given in the table, that quantity can be found with accuracy sufficient for ordinary purposes by the aid of *first differences*. It is to facilitate such interpolation that the logarithms of the pressures, densities, volumes, and quantities denoted by L, are given, together with the

successive differences of those logarithms (denoted by Δ); because the differences of the logarithms vary much less than those of the numbers to which they belong.

Suppose, for example, that it is required to find from Table VI. the volume V' corresponding to a pressure P' which lies between two of the pressures given in the table. Let P be the *next less* pressure to P' which is found in the table, and V the corresponding volume; then, approximately,

$$\log V' = \log V - (\log P' - \log P) \cdot \frac{-\Delta \log V}{\Delta \log P}; \dots (1.)$$

and similar methods may be applied to other quantities. The sign $-$ immediately prefixed to $\Delta \log V$ is merely the algebraical mode of indicating that V diminishes when P increases.

For example, let it be required to find the volume of a pound of steam in cubic feet when its absolute pressure is *two atmospheres*, or 29.4 lbs. upon the square inch, or 4232.8 lbs. on the square foot = P' . The next less pressure in the table is 4152. Then

$$\log P' = 3.6266; \log P = 3.6183; \log V = 1.1461;$$

$$\Delta \log P = 0.0678; -\Delta \log V = 0.0637;$$

and therefore,

$$\log V = 1.1461 - 0.0083 \cdot \frac{637}{678} = 1.1383;$$

and

$$V = 13.75 \text{ cubic feet per lb.}$$

280. **Back Pressure.**—If the steam working in steam engines were unmixed with air, and if it could escape without resistance and in an inappreciable short time from the cylinder after having completed the forward stroke, the back pressure would be simply, in non-condensing engines (conventionally called "*high pressure engines*"), the *atmospheric pressure* for the time; and in condensing engines, the pressure corresponding to the temperature in the condenser. This may be called the *pressure of condensation*.

The mean back pressure, however, always exceeds the pressure of condensation, and sometimes in a considerable proportion. One cause of this, which operates in condensing engines only, is the presence of air mixed with the steam, which causes the *pressure in the condenser*, and consequently the back pressure also, to be greater than the pressure of condensation of the steam. For example, an ordinary temperature in a condenser when working properly, is about 104° Fahrenheit, to which the corresponding pressure of steam is 152.6 lbs. on the square foot, or 1.06 lbs. on the square inch. But the absolute pressure in the best condensers is scarcely

ever less than 2 lbs. on the square inch, or nearly *double* of the pressure of condensation.

The principal cause, however, of increased back pressure, is resistance to the escape of the steam from the cylinder, by which, in condensing engines, the mean back pressure is caused to be from 1 to 3 lbs. on the square inch greater than the pressure in the condenser. There is as yet no satisfactory theory of that resistance, so that it cannot be computed for any proposed engine by means of a general formula.

The back pressure, therefore, in proposed condensing engines, can for the present only be estimated roughly from the results of experience in particular cases. The following is a summary of some such results:—

	MEAN BACK PRESSURE, p_2 .	
	Lbs. on the square foot.	Lbs. on the square inch.
Ratio of expansion from $1\frac{1}{2}$ to 3,...	720	5
" " from 4 to 7,....	648 to 504	$4\frac{1}{2}$ to $3\frac{1}{2}$
" " from 8 to 15,...	504 to 432	$3\frac{1}{2}$ to 3

There is a deficiency of precise experimental data on this subject, because of the frequent omission to observe the atmospheric barometer at the time when the indicator diagrams of steam engines are taken. The consequence of that omission is, that the diagrams show only the *effective* pressures of the steam, and not the *absolute* pressures, which are left to be roughly estimated by guessing the probable atmospheric pressure.

It is certain, that if sufficient experimental data existed, the back pressure would be found to vary with the speed of the engine, being greater at higher speeds, and also with the density of the steam at the commencement of the exhaust, and with the size of the exhaust port through which it escapes from the cylinder.

In non-condensing locomotive engines, a great number of experimental data as to back pressure have been collected and arranged, and to a certain extent reduced to a system of laws, in Mr. D. K. Clark's work *On Railway Machinery*. That author finds, that the *excess* of the back pressure above the atmospheric pressure varies nearly—

As the square of the speed;

As the pressure of the steam at the instant of *release*; that is, of the commencement of the exhaust;

Inversely as the square of the area of the orifice of the blast pipe, through which the steam is blown into the chimney to produce a draught.

Mr. Clark also finds, that the excess of back pressure is less, the greater the ratio of expansion; that it is less, the longer the *time*

during which the eduction of the steam lasts; and that it is increased by the presence of liquid water amongst the steam, being in certain cases greater in unprotected than in protected cylinders in the ratio of 1.72 to 1.

As an example of specific results obtained by Mr. Clark, it may be stated, that "with a mean of 16 per cent. of release,"—that is, with the exhaust port opened when the piston had performed 0.84 of its forward stroke—"with an admission of half stroke,"—that is, with the ratio of expansion 2, nearly, "and with a speed of piston of 600 feet per minute;" the excess of the back pressure above the atmospheric pressure, in protected cylinders, was about 0.163 of the excess of the pressure of the steam at the instant of release above the atmospheric pressure.

It is probable, that the general results arrived at by Mr. Clark may be safely applied to all engines, whether condensing or non-condensing, to the following extent:—

That in the same engine, going at the same speed, the excess of the mean back pressure above the pressure of condensation, varies nearly as the density of the steam at the end of the expansion;

And that in the same engine, with the same density of steam at the end of the forward stroke, that excess of back pressure varies nearly as the square of the speed.

281. Thermodynamic Function, and Adiabatic Curve, for Mixed Water and Steam.—When, as in the present investigation, the volume of a pound of water, and its variations, are treated as insensibly small, the value of the thermodynamic function consists simply of the first term of the expression in Article 246, equation 1; that is to say,

$$J \text{ hyp log } \tau;$$

J denoting, as usual, Joule's equivalent, or the dynamical value of the specific heat of water. Suppose the pound of water to be raised from a fixed temperature to any given absolute temperature τ , and then to be either wholly or partially evaporated; and let u be the volume of the steam produced, which for total evaporation is equal to v , the volume of one pound of saturated steam at the given boiling point, and for partial evaporation, may have any value less than v . Then from Article 255, equation 1, it is evident, that to complete the thermodynamic function for the aggregate of water and steam, we must add to the expression already found for the water in the liquid state, the following quantity:—

$$u \frac{d p}{d \tau};$$

giving for the complete *thermodynamic function for one lb. of water and steam*—

$$\phi = J \text{ hyp log } \tau + u \frac{d p}{d \tau} \dots \dots \dots (1.)$$

[The same expression may be made applicable to any other fluid by putting instead of J , $J c$, the dynamical specific heat of the fluid in question in the liquid state.]

The equation of an adiabatic curve is

$$\phi = \text{constant.}$$

This enables us to find the equation of the form of the curve BC in the diagram, fig. 109, Article 278, when that curve is adiabatic; that is, when the steam expands without receiving or giving out heat. Attending to the notation of Article 279, we have, in the present case, for the point B in the curve,

$$u_1 = v_1;$$

and for any other point,

$$J \text{ hyp log } \tau + u \frac{d p}{d \tau} = J \text{ hyp log } \tau_1 + v_1 \frac{d p_1}{d \tau_1}; \dots (2.)$$

from which is easily deduced the following expression for the volume u occupied by one lb. of water and steam at any pressure p :—

$$u = \frac{1}{\frac{d p}{d \tau}} \cdot \left(J \text{ hyp log } \cdot \frac{\tau_1}{\tau} + v_1 \frac{d p_1}{d \tau_1} \right); \dots \dots \dots (3.)$$

When *common* instead of *hyperbolic* logarithms are used in the calculation, for $J = 772$ is to be substituted,

$$J \text{ hyp log } 10 = 772 \times 2.3026 = 1777.6.$$

According to Article 255, equation 3,

$$\frac{d p}{d \tau} = p \left(\frac{B}{\tau^2} + \frac{2 C}{\tau^3} \right) \text{ hyp log } 10; \dots \dots \dots (4.)$$

by means of which formula, with the aid of equation 1 of Article 206, and the constants given in page 237, $\frac{d p}{d \tau}$ can be computed.

The use of the equation 3 for computing the value of u may be much facilitated, by employing the values of L , the *latent heat per cubic foot*, which are given for steam in Table IV. (and for æther in Table V.); for according to Article 255, equation 2 (neglecting the volume of the liquid water),

$$\frac{dp}{d\tau} = \frac{L}{\tau};$$

so that equation 3 of this Article becomes

$$u = \frac{\tau}{L} \left(J \text{ hyp log } \frac{\tau_1}{\tau} + \frac{v_1 L_1}{\tau_1} \right) \dots \dots \dots (5.)$$

A convenient modification of equations 3 and 5 is the following:—

Let the weight of steam under consideration be $D_1 = \frac{1}{v_1}$, so that its initial volume u_1 is *one cubic foot*. Then, instead of u may be put $r \left(= \frac{u}{v_1} \right)$, the *ratio in which the steam is expanded*; so that we have for the value of that ratio,

$$\begin{aligned} r &= \frac{1}{\frac{dp}{d\tau}} \left(J D_1 \text{ hyp log } \frac{\tau_1}{\tau} + \frac{dp_1}{d\tau_1} \right) \\ &= \frac{\tau}{L} \left(J D_1 \text{ hyp log } \frac{\tau_1}{\tau} + \frac{L_1}{\tau_1} \right) \dots \dots \dots (6.) \end{aligned}$$

282. Approximate Formula for Adiabatic Curve.—From the results of numerical calculations of the co-ordinates of adiabatic curves for steam, it has been deduced by trial, that for such pressures as usually occur in the working of steam engines, the relation between those co-ordinates is approximately expressed by the following statement:—*the pressure varies nearly as the reciprocal of the tenth power of the ninth root of the space occupied*; that is to say, in symbols

$$p \propto u^{-\frac{10}{9}} \text{ nearly} \dots \dots \dots (1.)$$

This formula belongs to the class already explained in Article 279, Method II.; the value of the exponents and co-efficients being

$$i = \frac{10}{9}; i - 1 = \frac{1}{9}; \frac{1}{i - 1} = 9; \frac{i}{i - 1} = 10 \dots (2.)$$

The preceding equation 1, and those deduced from it, are most expeditiously employed by the aid of a table of logarithms. In the absence of a table of logarithms, the *ninth root* of any ratio can be found by extracting the cube root of the cube root, either by the aid of a table of cube roots, or by ordinary arithmetic.

283. Liquefaction of Steam Working Expansively.—The volume

of one pound of saturated steam (neglecting the volume of the liquid water), according to Article 256, equation 1, is

$$v = \frac{H'}{L} = \frac{H'}{\tau \frac{d p}{d \tau}} \dots \dots \dots (1.)$$

H' being the latent heat of evaporation of one pound. It appears by computation, that the volume u given by equation 3 or equation 5 of Article 282 is less than v in all cases which occur in practice; from which it follows, that when steam expands in driving a piston, and receives no heat from without, a portion is liquefied.

To find under what conditions, and to what extent this condensation by expansive working will take place, we have for the proportion borne by the condensed steam to the whole mass of steam and water, the following expression:—

$$\frac{v-u}{v} = 1 - \frac{\tau}{H'} \left(J \text{ hyp log } \frac{\tau_1}{\tau} + v_1 \frac{d p_1}{d \tau_1} \right) \dots \dots \dots (2.)$$

The value of H' is given approximately in foot-lbs. per pound of steam by the formula

$$H' = a - b \tau = 1109550 - 540 \cdot 4 \tau \dots \dots \dots (3.)$$

For any other fluid, $J c$ would have to be put instead of J , and for a and b their proper values, supposing them to have been ascertained.

It may be shown by an investigation, which it is unnecessary here to give in detail, that the expression (2) is always positive so long as

$$\tau_1 \text{ is less than } \frac{a}{J c} \left(= 1437 \cdot 2 \text{ for steam} = 461 \cdot 2 + 976^\circ \right).$$

The principle just stated, as to the liquefaction of vapours by expansive working, was arrived at contemporaneously and independently, by Professor Clausius and the Author of this work in 1849. Its accuracy was subsequently called in question, chiefly on the ground of experiments which show that steam, after being expanded by being "wire-drawn," that is to say, by being allowed to escape through a narrow orifice, is super-heated, or at a higher temperature than that of liquefaction at the reduced pressure. Soon afterwards, however, Professor William Thomson proved that those experiments are not relevant against the conclusion in question, by showing the difference between the *free expansion* of an elastic fluid, in which all the energy due to the expansion is expended in agitating the particles of the fluid, and is reconverted into heat,

and the expansion of the same fluid *under a pressure equal to its own elasticity*, when the energy developed is all communicated to external bodies, such, for example, as the piston of an engine.

284. *Efficiency of Steam in an Unjacketed Cylinder.*—In the present Article, the cylinder is supposed to be sufficiently protected against any appreciable loss of heat by conduction; and the steam is assumed to expand without receiving or emitting heat, so that BC in fig. 109, Article 278, is an adiabatic curve.

The area ABCD, contained between that curve and the straight lines AB and CD, corresponding to the pressures p_1 and p_2 at the beginning and end of the expansion, has the following value, when the mass of steam under consideration is *one pound*:—

$$\begin{aligned} \text{A B C D} &= \int_{p_2}^{p_1} u \, dp = \int_{p_2}^{p_1} dp \cdot \frac{1}{\frac{dp}{d\tau}} \left(J \text{ hyp log } \frac{\tau_1}{\tau} + v_1 \cdot \frac{dp_1}{d\tau_1} \right) \\ &= J \left\{ \tau_1 - \tau_2 \left(1 + \text{hyp log } \frac{\tau_1}{\tau_2} \right) \right\} + (\tau_1 - \tau_2) v_1 \frac{dp_1}{d\tau_1} \dots (1.) \end{aligned}$$

In fluids other than water, Jc is to be put instead of J .

Inasmuch as the latent heat of evaporation of one pound of steam at τ_1 is

$$v_1 \tau_1 \frac{dp_1}{d\tau_1} = H' = a - b \tau_1 = 1109550 - 540.4 \tau_1 \text{ nearly,}$$

we may transform the expression 1 into

$$J \left\{ \tau_1 - \tau_2 \left(1 + \text{hyp log } \frac{\tau_1}{\tau_2} \right) \right\} + \frac{\tau_1 - \tau_2}{\tau_1} H' \dots (1 \text{ A.}^*)$$

It is often convenient to consider the action, not of *one pound* of steam, but so much steam as fills *one cubic foot* when first admitted into the cylinder at the pressure p_1 . In this case, we have

$$\overline{\text{A B}} = u_1 = 1 \text{ cubic foot;}$$

$$\overline{\text{D C}} = u_2 = r \text{ ratio of expansion;}$$

and the area ABCD is found by multiplying the expression (1)

* In using the formulæ 1 and 1 A, and those deduced from them, the following approximations are convenient:—

$$\text{hyp log } \frac{\tau_1}{\tau_2} = \frac{2(\tau_1 - \tau_2)}{\tau_1 + \tau_2} \text{ nearly.}$$

$$\tau_1 - \tau_2 \left(1 + \text{hyp log } \frac{\tau_1}{\tau_2} \right) = \frac{(\tau_1 - \tau_2)^2}{\tau_1 + \tau_2} \text{ nearly.}$$

by $D_1 = \frac{1}{v_1}$, the weight of one cubic foot of saturated steam at the pressure of admission. Observing further, that

$$\frac{d p_1}{d \tau_1} = \frac{L_1}{\tau_1},$$

we find, per cubic foot of steam admitted,

$$A B C D = J D_1 \left\{ \tau_1 - \tau_2 \left(1 + \text{hyp log } \frac{\tau_1}{\tau_2} \right) \right\} + \frac{\tau_1 - \tau_2}{\tau_1} \cdot L_1; \dots (2.)$$

in which D_1 and L_1 can be found from Table IV.

From the above equation 2, and the properties of the adiabatic curve already explained in Article 281, are deduced the following formulæ, most of which have reference to the action of *one cubic foot of steam admitted*; pressures being expressed in *lbs. on the square foot*:—

DATA.

- p_1 , absolute pressure of admission;
- p_2 , absolute pressure at end of expansion;
- p_3 , mean absolute back pressure;
- τ_4 ($= T_4 + 461.2$ Fahrenheit), absolute temperature of feed water;
- T_5 , ordinary temperature of condensation;
- T_6 , ordinary temperature of atmosphere.

RESULTS.

Temperatures corresponding to the several pressures to be found by equation 2, Article 206, or by Table IV.

Ratio of expansion—

$$\frac{D C}{A B} = r = \frac{\tau_2}{L_2} \left(772 D_1 \text{hyp log } \frac{\tau_1}{\tau_2} + \frac{L_1}{\tau_1} \right); \dots (3.)$$

Energy per cubic foot of steam admitted—

$$U D_1 = J D_1 \left\{ \tau_1 - \tau_2 \left(1 + \text{hyp log } \frac{\tau_1}{\tau_2} \right) \right\} + \frac{\tau_1 - \tau_2}{\tau_1} L_1 + r (p_2 - p_3); \dots (4.)$$

Mean effective pressure, or energy per cubic foot swept through by piston—

$$p_m - p_3 = \frac{U D_1}{r} \dots (5.)$$

For lbs. on the square inch, divide this by 144.

Heat expended per cubic foot of steam admitted—

$$H_1 D_1 = J D_1 (\tau_1 - \tau_2) + L_1; \dots\dots\dots(6.)$$

Heat expended per cubic foot swept through by piston, or pressure equivalent to heat expended—

$$\frac{H_1 D_1}{r}; \dots\dots\dots(7.)$$

Efficiency of steam, $\frac{U}{H_1}; \dots\dots\dots(8.)$

Net feed water per cubic foot of steam admitted—

$$D_1; \dots\dots\dots(9.)$$

Net feed water per cubic foot swept through by piston—

$$\frac{D_1}{r}; \dots\dots\dots(10.)$$

Heat rejected per cubic foot of steam admitted—

$$H_2 D_1 = (H_1 - U) D_1; \dots\dots\dots(11.)$$

Heat rejected per cubic foot swept through by piston—

$$\frac{H_2 D_1}{r} = \frac{(H_1 - U) D_1}{r}; \dots\dots\dots(12.)$$

Lbs. of water to be injected into the condenser (if any) to abstract that heat—

$$\frac{H_2 D_1}{r J (T_5 - T_6)}; \dots\dots\dots(13.)$$

Cubic feet to be swept through by the piston per minute, for each indicated horse-power—

$$\frac{33000}{p_m - p_s} = \frac{33000 r}{U D_1}; \dots\dots\dots(14.)$$

Available heat expended per indicated horse-power per hour—

$$1980000 \frac{H_1}{U} \dots\dots\dots(15.)$$

The following is a numerical example:—

DATA.

Pressures.	Lbs. per square inch.	Lbs. per square foot.
Initial, p_1 .	33·71	4854
Final, p_2 .	10·16	1463
Back pressure, p_3 .	5·00	720

Temperatures.	Ordinary, T.	Absolute, τ .
Of feed water (4.)	95°	556·2
Of condensation (5.)	104	
Of atmosphere (6.)	59	

RESULTS.

Quantities found by Table IV.	T.	τ .	L.	D.
Corresponding to p_1 .	257	718·2	59720	0·08285
" " p_2 .	194	655·2	20280	0·02685

Ratio of expansion—

$$r = \frac{655\cdot2}{20280} \left(772 \times 0\cdot08285 \times \text{hyp log } \frac{718\cdot2}{655\cdot2} + \frac{59720}{718\cdot2} \right) = 2\cdot875.$$

Energy per cubic foot of steam admitted—

$$\begin{aligned} U D_1 &= 772 \times 0\cdot08285 \left\{ 718\cdot2 - 655\cdot2 \left(1 + \text{hyp log } \frac{718\cdot2}{655\cdot2} \right) \right\} \\ &\quad + \frac{63}{718\cdot2} \times 59720 + 2\cdot875 \times 743 \\ &= 182 + 5239 + 2136 = 7557 \text{ foot-lbs.} \end{aligned}$$

Mean effective pressure—

$$\begin{aligned} \frac{U D_1}{r} &= \frac{7557}{2\cdot875} = 2629 \text{ lbs. on the square foot} \\ &= 18\cdot25 \text{ lbs. on the square inch.} \end{aligned}$$

Heat expended per cubic foot of steam admitted—

$$\begin{aligned} H_1 D_1 &= 772 \times 0\cdot08285 (718\cdot2 - 556\cdot2) + 59720 \\ &= 10362 + 59720 = 70082 \text{ foot-lbs.} \end{aligned}$$

Heat expended per cubic foot swept through by piston, or pressure equivalent to heat expended—

$$\begin{aligned} \frac{H_1 D_1}{r} &= \frac{70082}{2\cdot875} = 24376 \text{ lbs. on the square foot} \\ &= 169\cdot3 \text{ lbs. on the square inch.} \end{aligned}$$

Efficiency of steam—

$$\frac{U}{H_1} = \frac{7559}{70082} = \frac{2629}{24376} = \frac{18.25}{169.3} = 0.1077.$$

Net feed water per cubic foot swept through by piston—

$$\frac{D_1}{r} = \frac{0.08285}{2.875} = 0.0288 \text{ lb.} = 0.00046 \text{ cubic foot nearly.}$$

Heat rejected per cubic foot of steam admitted—

$$H_2 D_1 = 70082 - 7557 = 62525 \text{ foot-lbs.}$$

Heat rejected per cubic foot swept through by piston—

$$\frac{62525}{2.875} = 24376 - 2629 = 21747.$$

Injection water required to condense the steam, per cubic foot swept through by piston—

$$\frac{21747}{772 \times (104 - 59)} = 0.626 \text{ lb.} = \frac{1}{100} \text{ cubic foot nearly.}$$

Cubic feet to be swept through by the piston per minute, for each indicated horse-power—

$$\frac{33000}{2629} = 12.55$$

(or $12.55 \times 60 = 753$ cubic feet per hour).

Available heat expended per indicated horse-power per hour—

$$\frac{1,980,000}{\text{efficiency} = 0.1077} = 18,384,400 \text{ foot-lbs.}$$

To show how this expenditure of available heat is connected with the consumption of coal, let the coal be of such a quality, that the *total heat of combustion* of one lb. of it is

$$10,000,000 \text{ foot-lbs.}$$

(corresponding to a theoretical evaporative power of about 13.4).

Let the efficiency of the furnace be 0.54; so that the *available* heat of combustion of one lb. of coal is

$$5,400,000 \text{ foot-lbs.}$$

Then the consumption of coal in the engine now under consideration, per indicated horse-power per hour, is

$$\frac{18384400}{5400000} = 3.405 \text{ lbs.}$$

The following are some deductions from the previous calculations:—

Net feed water per indicated horse-power per hour—

$$0.0288 \times 753 = 21.7 \text{ lbs.} = 0.347 \text{ cubic foot.}$$

Injection water per indicated horse-power per hour—

$$0.626 \times 753 = 471.4 \text{ lbs.} = 7.54 \text{ cubic feet.*}$$

285. Approximate Formulæ for Unjacketed Cylinders.—The formulæ in the preceding Article which give the mean effective pressure, and the work of a given quantity of steam, are inconvenient in practice from the length of the calculations which their use involves, and from the circumstance, that although they serve to compute directly the ratio of expansion when the initial and final pressures are given, they cannot be so employed when the initial pressure and ratio of expansion, but not the final pressure, are given, except by the aid of a tedious process of trial and error.

For practical use in ordinary cases, therefore, it is desirable to have a set of formulæ in which the computations are less tedious, and which can be used directly when the ratio of expansion is one of the data. When the initial pressure is not less than one atmosphere, nor more than twelve atmospheres, such a set of formulæ, sufficiently accurate in all ordinary cases, are deduced from the fact, already stated in Article 282, that during the expansive working of steam represented by an adiabatic line,

$$p \propto u^{-\frac{10}{9}} \text{ nearly.}$$

The following are the formulæ thus obtained:—

DATA.

p_1 , absolute pressure of admission;

r , ratio of expansion;

p_3 , mean absolute back pressure;

τ_4 , absolute temperature of feed water—

$$(\text{= } T_4 + 461^{\circ}.2);$$

T_5 , temperature of condensation;

T_6 , temperature of atmosphere.

* The fundamental formulæ of Article 284 were first published in a paper sent to the Royal Society in December, 1853, and published in the *Philosophical Transactions* for 1854. The same formulæ were also discovered independently by Professor Clausius about 1855, and published by him in Poggendorff's *Annalen* for 1856.

RESULTS.

Final pressure, $p_2 = p_1 \cdot r^{-\frac{10}{9}}$;.....(1.)

Mean total pressure—
 $p_m = p_1 \left(10 r^{-1} - 9 r^{-\frac{10}{9}} \right)$;.....(2.)

Mean effective pressure—
 $p_m - p_3 = p_1 \left(10 r^{-1} - 9 r^{-\frac{10}{9}} \right) - p_3$(3.)

The three preceding formulæ are applicable to pressures expressed in any kind of units.

Energy per cubic foot of steam admitted—

$$r (p_m - p_3) = p_1 \left(10 - 9 r^{-\frac{1}{9}} \right) - r p_3; \dots\dots (4.)$$

in which the pressures are in lbs. on the square foot.

To facilitate the use of these formulæ, the values of the ratios

$$\frac{p_m}{p_1} = 10 r^{-1} - 9 r^{-\frac{10}{9}}; \text{ or } \frac{10}{r} - \frac{9}{r^{\frac{10}{9}}}$$

and

$$\frac{r p_m}{p_1} = 10 - 9 r^{-\frac{1}{9}};$$

and their reciprocals, are given in Table VII. at the end of the volume, for values of the "admission" or "cut off," $\frac{1}{r}$, increasing at first by differences of 0.025, and afterwards by differences of 0.05. Intermediate values of the above ratios can easily be computed, when required, from those given in the table, by interpolation.

Where the approximate formulæ of the present Article are used for calculating the energy exerted, and the mean effective pressure, the expenditure of heat, the feed water, injection water, &c., may easily be computed by the formulæ already given in the preceding Article. But in cases where special accuracy is not required, the expenditure of heat may be computed approximately with less trouble by the following approximate formulæ:—

Heat expended in foot-lbs. per cubic foot of steam admitted—

$$H_1 D_1 = 13\frac{1}{3} p_1 + 4000 \text{ nearly}; \dots\dots (5.)$$

p_1 being in lbs. on the square foot;

Heat expended per cubic foot swept through by piston, or pressure equivalent to heat expended—

$$\frac{H_1 D_1}{r} = \frac{13\frac{1}{3} p_1 + 4000 \text{ lbs. per square foot}}{r}; \dots\dots (6.)$$

$$\left. \begin{array}{l} \text{Equivalent pressure in} \\ \text{lbs. per square inch} \end{array} \right\} = \frac{13\frac{1}{2} p_1 + 27\cdot7 \text{ lbs. per square inch}}{r} \cdot (6 \text{ A.})$$

In the following numerical example, the preceding approximate formulæ are applied to the case already calculated in the preceding Article, the ratio of expansion being supposed to be given.

DATA.

Initial pressure, $p_1 = 33\cdot71$ lbs. per square inch ;

Ratio of expansion, $r = 2\cdot875$, so that

$$\text{Admission, } \frac{1}{r} = 0\cdot348 ;$$

Mean back pressure—

$$p_3 = 5 \text{ lbs. per square inch.}$$

RESULTS.

Computation of the ratio $\frac{p_m}{p_1}$, from Table VII.—

$\frac{1}{r}$	$\Delta \cdot \frac{1}{r}$	$\frac{p_m}{p_1}$	$\Delta \cdot \frac{p_m}{p_1}$
·3		·639	
	·05		·058 = $\Delta \cdot \frac{1}{r} \times 1\cdot16$ nearly
·35		·697	

Therefore, for $\frac{1}{r} = 0\cdot348 = 0\cdot35 - 0\cdot002$,

$$\frac{p_m}{p_1} = 0\cdot697 - 0\cdot002 \times 1\cdot16 = 0\cdot695 \text{ nearly ;}$$

Mean total pressure—

$$p_m = 33\cdot71 \times 0\cdot695 = 23\cdot43 \text{ lbs. on the square inch.}$$

Mean effective pressure—

$$p_m - p_3 = 23\cdot43 - 5\cdot00 = 18\cdot43 \text{ lbs. on the square inch ;}$$

The same as computed by } 18·25 " "

the exact formula }

Difference,..... + 0·18 " "

or about $\frac{1}{16}$.

Pressure equivalent to heat expended—

$$\frac{13\frac{1}{2} \times 33.71 + 27.7}{2.875} = 166 \text{ lbs. on the square inch;}$$

The same as computed } 169.3 " "
by the exact formula, }

Difference,..... — 3.3 " "

or about $\frac{1}{10}$.

$$\text{Efficiency of the steam, } \frac{18.43}{166} = 0.1110$$

The same as computed by } 0.1077
the exact formulæ,..... }

Difference,..... + 0.0033

or about $\frac{1}{10}$.

The errors arising from the use of the approximate formulæ, of which examples have just been given, are in most cases practically unimportant.*

286. *Use of the Steam Jacket, and Hot Air Jacket.*†—The conclusion theoretically demonstrated in Article 283, that when steam or other saturated vapour in expanding performs work by driving a piston, and receives no heat from without during that expansion, a portion of it must be liquefied, is confirmed by experience in actual steam engines; for it has been ascertained, that the greater part of the liquid water which collects in unjacketed cylinders, and which was once supposed to be wholly carried over in the liquid state from the boiler (a phenomenon called "pruning") is produced by liquefaction of part of the steam during its expansion; and also that the principal effect of the "*jacket*," or annular casing enveloping the cylinder, filled with hot steam from the boiler, which was one of the inventions of Watt, is to prevent that liquefaction of the steam in the cylinder.

That liquefaction does not, when it first takes place, directly constitute a waste of heat or of energy; for it is accompanied by a corresponding performance of work. It does, however, afterwards, by an indirect process, diminish the efficiency of the engine; for the water which becomes liquid in the cylinder, probably in the form of mist and spray, acts as a distributor of heat, and equalizer

* These approximate formulæ were first published in *A Manual of Applied Mechanics*, 1858, Article 656.

† Articles 286, 287, 288, and 289, are to a great extent extracted and abridged from a paper read to the Royal Society in January, 1859.

of temperature, abstracting heat from the hot and dense steam during its admission into the cylinder, and communicating that heat to the cool and rarefied steam which is on the point of being discharged, and thus lowering the initial pressure and increasing the final pressure of the steam, but lowering the initial pressure much more than the final pressure is increased; and so producing a loss of energy which cannot be estimated theoretically. Accordingly, in all cases in which steam is expanded to more than three or four times its initial volume, it has in practice been found advantageous to envelop the cylinder in a steam jacket. The liquefaction which would otherwise have taken place in the cylinder, takes place in the jacket instead, where the presence of the liquid water produces no bad effect; and that water is returned to the boiler.

In double cylinder engines, where the expansion of the steam begins in a smaller cylinder, and finishes in a larger, the usual practice is to have steam jackets round both cylinders; but in a few examples in which the smaller cylinder alone is jacketed, the liquefaction is found to be prevented, showing that the steam during its passage from the small into the large cylinder, receives sufficient heat either directly from the small cylinder, or indirectly by conduction from the small to the large cylinder (which is in close contact with the small cylinder), to prevent any appreciable portion of it from condensing.

It is desirable that a small quantity of the steam, not appreciable in calculating the efficiency of the engine, should be liquefied, in order to lubricate the packing of the piston. This generally does take place in jacketed engines, and is probably the effect of attraction between the particles of water and the metal.

The effect of a steam jacket in preventing condensation may be produced by a *hot air jacket*; that is, by a flue round the cylinder; or by enclosing the cylinder in the smoke box, as is done in many locomotive engines. The advantages of this are well shown in Mr. D. K. Clark's work on *Railway Machinery*. With this apparatus, however, there is not the same security against over dryness of the packing that there is with the steam jacket.

287. Efficiency of Dry Saturated Steam.—In the following investigation, it is assumed that the steam in the cylinder, while expanding, receives just enough of heat from the steam in the jacket to prevent any appreciable part of it from condensing, without superheating it. This assumption is founded on the fact, that dry steam is a bad conductor of heat as compared with liquid water, or with cloudy steam, and that after cloudy steam has received enough of heat to make it dry, or nearly dry, it will receive additional heat very slowly.

The assumption is justified by the fact, that its results are confirmed by experiment.

The symbol v is used to denote the volume of one pound of steam in cubic feet, and the symbol p to denote pressure in pounds on the square foot, so that pressure in pounds on the square inch is denoted by $\frac{p}{144}$.

In fig. 110, let B C K be the curve whose co-ordinates represent the volumes and pressures of dry saturated steam.

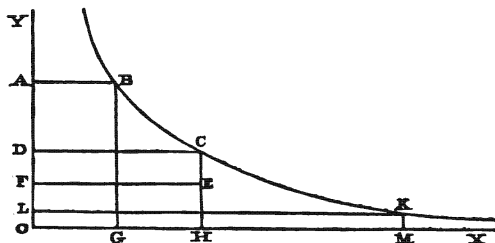

Fig. 110.

Let $\overline{OA} = p_1$, and $\overline{AB} = v_1$, represent the pressure and volume of admission, and τ_1 the corresponding absolute temperature;

Let $\overline{OD} = p_2$, and $\overline{DC} = v_2$, represent the pressure and volume at the end of the expansion, and τ_2 the corresponding absolute temperature; then

$$\frac{v_2}{v_1} = r \text{ is the ratio of expansion, and}$$

$$\frac{v_1}{v_2} = \frac{1}{r} \text{ the admission, or effective cut-off.}$$

Let $\overline{OF} = p_3$ be the pressure of exhaustion;

Let τ_4 be the absolute temperature of the feed water.

The energy exerted by one pound of steam is represented by the area of the diagram, consisting of

$$\text{the area } A B C D = \int_{p_2}^{p_1} v \, dp, \text{ and}$$

$$\text{the area } E F D C = v_2 (p_2 - p_3);$$

while the expenditure of heat per pound of steam consists of the following parts:—

The sensible heat $J (\tau_1 - \tau_4)$; the latent heat of evaporation

at τ_1 ; and the latent heat of expansion, which is communicated from the steam in the jacket to that in the cylinder.

The work of one pound of dry saturated steam exceeds that of one pound of steam which expands from the same initial pressure to the same final pressure without receiving heat, to an amount represented by the excess of the area $A B C E F A$ above the corresponding area for an unjacketed cylinder, while the expenditure of heat is greater by the quantity which the steam in the cylinder receives during the expansion represented by the curve $B C$.

The latent heat of evaporation of one pound of steam at the absolute temperature τ , may be expressed with accuracy sufficient for the purposes of the present investigation, by the formula

$$H' = a - b \tau; \dots\dots\dots(1.)$$

where

$$a = 1109550 \text{ foot-lbs.};$$

$$b = 540.4 \text{ foot-lbs. per degree of Fahrenheit.}$$

To find the area $A B C D A$, which represents part of the energy corresponding to any value of p , the value of v is to be expressed in terms of H' , the corresponding latent heat of evaporation, according to the principle of Article 256, giving

$$v = \frac{a - b \tau}{\tau \frac{d \tau}{d p}},$$

which, being multiplied by $\frac{d p}{d \tau} d \tau$, and integrated between t_1 and t_2 , the initial and final temperatures of the expanding steam, we obtain for the area $A B C D A$ —

$$\begin{aligned} \int_{p_2}^{p_1} v d p &= \int_{\tau_2}^{\tau_1} \left(\frac{a}{\tau} - b \right) d \tau \\ &= a \cdot \text{hyp. log. } \frac{\tau_1}{\tau_2} - b (\tau_1 - \tau_2); \dots\dots\dots(2.) \end{aligned}$$

to which, adding the rectangle $D C E F$, the energy exerted on the piston by one pound of steam is found to be

$$\begin{aligned} U' &= \int_{v_2}^{p_1} v d p + v_2 (p_2 - p_3) \\ &= a \cdot \text{hyp. log. } \frac{\tau_1}{\tau_2} - b (\tau_1 - \tau_2) + v_2 (p_2 - p_3); \dots\dots(3.) \end{aligned}$$

in which

$$a = 1109550 \text{ foot-pounds}; \quad b = 540.4 \text{ pounds per degree of Fah.}$$

The MEAN EFFECTIVE PRESSURE, or work per unit of volume traversed by the piston, is

$$\frac{U}{v_2} \dots \dots \dots (4.)$$

The heat expended per pound of steam, by a different mode of division from that previously given, is computed as follows:—

Part of the sensible heat for raising one pound of water from the temperature of the feed to the final temperature of the expansion,—

$$J (\tau_3 - \tau_4);$$

latent heat of evaporation at the temperature τ_2 ,—

$$H'_2 = a - b \tau_2;$$

heat transformed into mechanical energy between the temperatures τ_1 and τ_2 ,—

$$A B C D A = \int_{p_2}^{p_1} v d p, \text{ as in equation 2.}$$

The addition of these quantities gives for the whole expenditure of heat in foot-pounds of energy per pound of steam,—

$$\begin{aligned} \mathfrak{h} &= J (\tau_3 - \tau_4) + a - b \tau_2 + \int_{p_2}^{p_1} v d p \\ &= J (\tau_3 - \tau_4) + a \left(1 + \text{hyp log } \frac{\tau_1}{\tau_2} \right) - b \tau_1 \dots \dots \dots (5.) \end{aligned}$$

($J = 772$ foot-pounds per degree of Fahrenheit).

The heat expended per unit of space traversed by the piston is equivalent to a pressure whose intensity is

$$\mathfrak{h} \div v_2 \dots \dots \dots (6.)$$

The EFFICIENCY of the steam is the ratio,

$$U' \div \mathfrak{h}, \dots \dots \dots (7.)$$

of the energy exerted by the steam on the piston to the heat expended on the steam; and that ratio having been determined, the available heat of a pound of fuel may be computed from the indicated work per pound of fuel, or *vice versa*, by means of the equation,—

$$\frac{\text{available heat}}{\text{indicated work}} = \frac{\mathfrak{h}}{U'} \dots \dots \dots (8.)$$

In the practical use of equations 3, 4, 5, 6, 7, and 8, the usual data are,—

the initial pressure p_1

the ratio of expansion τ ,

the back pressure p_3 ,

and the *absolute temperature of the feed-water $t_4 = T_4 + 461^{\circ}.2$.*

From p_1 , by the aid of known formulæ or of Table VI., are to be found τ_1 and v_1 . Then

$$\tau v_1 = v_2;$$

and from v_2 , by the aid of the same formulæ or of Table VI., are to be found τ_2 and p_2 , and thus are completed the data for the use of equations 3 and 5.

Let $\overline{OL} = p_0$ represent the pressure, and $\overline{LK} = v_0$ the volume, of a pound of steam at some standard temperature, such as that of melting ice ($\tau_0 = 32^{\circ} + 461^{\circ}.2 = 493^{\circ}.2$ Fahrenheit), and let

$$U = \int_{p_0}^p v dp = a \cdot \text{hyp log } \frac{\tau}{\tau_0} - b(\tau - \tau_0) \dots \dots \dots (9.)$$

be the area contained between LK and another parallel ordinate of the curve BCK corresponding to the absolute temperature τ .

Then by the aid of values of the function U, as given or interpolated in Table VI., the equations 3 and 5 can be put in the following form:—

$$U' = U_1 - U_2 + v_2(p_2 - p_3); \dots \dots \dots (10.)$$

$$h = U_1 - U_2 + J(\tau_2 - \tau_4) + a - b\tau_2 \dots \dots \dots (11.)$$

$$= U_1 - U_2 + H_2 - h_4; \dots \dots \dots (12.)$$

in which last expression for the heat expended, H_2 denotes the *total heat of evaporation, from τ_0 , at τ_2* , and h_4 the heat saved in consequence of the temperature of the feed-water being T_4 , instead of that of melting ice,—both quantities as given or interpolated in the columns respectively headed H and h in Table VI.

The following statement then gives at one view the formulæ applicable to engines worked by sensibly dry saturated steam:—

DATA.

p_1, τ, p_3, τ_4 , as already explained.

RESULTS.

v_1 , volume of one lb. of steam when admitted, to be found or interpolated in the column headed V, Table VI.

Volume at end of expansion,—

$$v_2 = r v_1; \dots\dots\dots(13.)$$

Final pressure, p_2 , and temperature T_2 , to be found or interpolated in the columns headed P and T, Table VI.

U' , energy exerted by, and h , heat expended on, one lb. of steam, to be found by equations 10 and 12, with Table VI., or by equations 3 and 5, without the Table.

Mean effective pressure,—

$$p_m - p_3 = \frac{U'}{r v_1} \dots\dots\dots(14.)$$

Pressure equivalent to expenditure of available heat,—

$$p_h = \frac{h}{r v_1}; \dots\dots\dots(15.)$$

Efficiency of steam,—

$$\frac{p_m - p_3}{p_h} = \frac{U'}{h}; \dots\dots\dots(16.)$$

Net feed water per cubic foot swept through by piston,—

$$\frac{1}{r v_1} = \frac{D_1}{r}; \dots\dots\dots(17.)$$

Heat rejected per lb. of steam,—

$$h - U' = H_2 - h_4 - v_2(p_2 - p_3); \dots\dots\dots(18.)$$

Heat rejected per cubic foot swept through by piston,—

$$\frac{h - U'}{r v_1} = p_h - p_m + p_3; \dots\dots\dots(19.)$$

Injection water required per lb. of steam—

(T_5 , temperature of condensation,
 T_6 , temperature of atmosphere).

$$\frac{h - U'}{772 \left(\frac{T_5 - T_6}{2 D} \right)}; \dots\dots\dots(20.)$$

Injection water required per cubic foot swept through by piston—

$$\frac{p_h - p_m + p_s}{772 (T_5 - T_6)}; \dots\dots\dots(21.)$$

Cubic feet swept through by piston per minute for each indicated horse-power—

$$\frac{33000}{p_m - p_s}; \dots\dots\dots(22.)$$

Available heat expended per hour in foot-lbs. per indicated horse-power—

$$\frac{1,980,000}{\text{Efficiency}} = \frac{1,980,000 p_h}{p_m - p_s} \dots\dots\dots(23.)$$

In applying these formulæ to an engine actually working, whose speed has been ascertained, let

A be the area of the piston;

s the distance through which it moves at each forward stroke if single acting, or during a *double stroke* if double acting;

N the number of revolutions per minute;

R the total resistance reduced to the piston; then, as in Article 263, formula 5, and Article 264, formula 3, the *energy exerted per minute* is

$$N s R = N s A (p_m - p_s); \dots\dots\dots(24.)$$

and the *indicated horse-power—*

$$\frac{N s A (p_m - p_s)}{33000}; \dots\dots\dots(25.)$$

also, the available heat expended per minute is

$$N s A p_h \dots\dots\dots(26.)$$

288. **Approximate Formulæ for Dry Saturated Steam.**—As the formulæ of the preceding Article require in their use a considerable amount of calculation, it is desirable to have, for the purpose of solving ordinary practical problems, approximate formulæ of a more simple kind. Those which will now be explained have been arrived at by a process of trial, and their agreement with the exact formulæ, and with experiment, has been tested for initial pressures ranging from 30 to 120 pounds on the square inch, and for ratios of expansion varying from 4 to 16. They may therefore be applied with confidence to engines working within these limits, and probably somewhat above them; but for pressures much exceeding 120 lbs. on the inch, and ratios of expansion much exceeding 16, it is advisable for the present to use the exact formulæ.

The foundation of the approximate formulæ is the fact, that for pressures not exceeding 120 lbs. on the inch, or 17,280 lbs. on the square foot, the equation of the curve B C K, fig. 110, is very nearly

$$p \propto v^{-\frac{17}{16}} \dots \dots \dots (1.)$$

This equation is very convenient in calculation, because the sixteenth root can be extracted with great rapidity to a degree of accuracy sufficient for practical purposes, by the aid of a table of squares alone; and, by a little additional labour, without any tables whatsoever.

Let r , as before, be the ratio of expansion; then we have evidently,

the final pressure— $p_2 = p_1 \cdot r^{-\frac{17}{16}}; \dots \dots \dots (2.)$

the energy exerted on the piston by one pound of steam = area A B C F A

$$= U' = \int_{p_2}^{p_1} v \, dp + (p_2 - p_3) v_2$$

$$= v_2 \left\{ p_1 \left(17 r^{-1} - 16 r^{-\frac{17}{16}} \right) - p_3 \right\}; \dots \dots \dots (3.)$$

the mean total pressure, $\frac{U'}{v_2} + p_3; \dots \dots \dots (4.)$

$$= p_m = p_1 \left(17 r^{-1} - 16 r^{-\frac{17}{16}} \right); \dots \dots \dots (5.)$$

the mean effective pressure, or energy exerted per cubic foot—

$$p_m - p_3 = \frac{U'}{v_2} = p_1 \left(17 r^{-1} - 16 r^{-\frac{17}{16}} \right) - p_3 \dots \dots \dots (6.)$$

It is evident, that if the pressure of exhaustion p_3 be given, and any two out of the three following quantities—the initial pressure p_1 , the mean effective pressure $p_m - p_3$, the ratio of expansion r —the fourth quantity can be calculated directly, if it is one or other of the pressures $p_1, p_m - p_3$; and if it is the expansion r , it can be found by approximation.

The approximate formula for the expenditure of heat per lb. of steam, which has been found by trial to agree very closely with the exact formula within the limits already specified, and when the feed water is supplied at a temperature of from 100° to 120° Fahrenheit, is as follows:—

$$h = 15\frac{1}{2} p_1 v_1 = \frac{15\frac{1}{2} p_1 v_2}{r}; \dots \dots \dots (7.)$$

so that the *heat expended per cubic foot*, or the *pressure per square foot of piston* to which the expenditure of heat is *equivalent*, is

$$p_h = \frac{h}{v_2} = \frac{15\frac{1}{2} p_1}{r} \dots\dots\dots(8.)$$

This gives for the *efficiency*

$$\frac{p_m - p_3}{p_h} = \frac{U'}{h} = \frac{17 - 16 r^{-\frac{1}{16}}}{15\frac{1}{2}} - \frac{r p_3}{15\frac{1}{2} p_1} \dots\dots\dots(9.)$$

by means of which, when the work of a pound of coal is known, its available heat can be computed, and *vice versa*, as with the exact formula.

To facilitate the use of these approximate formulæ, Table VIII., at the end of the volume, gives the ratios

$$\frac{p_m}{p_1} = 17 r^{-1} - 16 r^{-\frac{17}{16}}, \text{ and } \frac{r p_3}{r p_1} = \frac{17}{r} - \frac{16}{r^{\frac{17}{16}}}$$

$$\frac{r p_m}{p_1} = 17 - 16 r^{-\frac{1}{16}}, \text{ and } \frac{r p_3}{p_1} = \frac{17}{r} - \frac{16}{r^{\frac{17}{16}}}$$

and their reciprocals, for a series of values of the *admission* or *effective cut-off*, $\frac{1}{r}$, increasing at first by differences of 0.025, and afterwards by differences of 0.05. Intermediate values of those ratios can easily be interpolated when required.

289. **Examples of the Action of Dry Saturated Steam.**—The following examples, being taken from the performance of actual engines, are intended at once to illustrate the use of the formulæ in Articles 287 and 288, and to compare their results with those of experiment.

In comparing the results of formulæ for the expansive working of steam with those of the indicator diagrams of engines, it is not to be expected that the indicated pressures corresponding to particular volumes, during or at the end of the expansion, will closely agree with those given by calculation; because considerable deviations, alternately upwards and downwards, arise from the friction of the indicator, the elastic vibrations of the indicator spring, and the pulsations of the particles of the steam itself. In the course of a complete stroke, however, those deviations neutralize each other, so that the indicated *mean effective pressure* ought to agree with that given by theory, if the theory is sound. About half a pound on the square inch, or 72 lbs. on the square foot, may be considered as an ordinary limit of error in indicator diagrams.

Two examples of the application of the formulæ to actual engines, and of the comparison of their results with those of experiment, are annexed.

Example I.—Double-cylinder engines of 744 indicated horse-power, calculated by exact formulæ :—*

DATA—

	Bottom of cylinders.	Top of cylinders.
Pressure of admission, $p_1 \div 144$,.....	33·7	34·3
Back pressure, $p_3 \div 144$,.....	4·0	4·0
Ratio of expansion, r ,.....	$4\frac{1}{8}$	$6\frac{1}{4}$
Ordinary temperature of feed water $T_4 =$ about 104° Fahrenheit.		

CALCULATED RESULTS—

	Bottom.	Top.
Final volume of 1 lb. of steam, $v_2 = r v_1$,	50·375	74·4
Final pressure, $p_2 \div 144$,.....	7·367	4·867
Work of 1 lb. of steam, U' ,.....	109552	117338
Mean effective pressure in pounds on the inch,.....	$\left. \begin{array}{l} U' \\ 144 v_2 = \frac{p_m - p_3}{144} \end{array} \right\}$	
	15·1	10·95
Mean of both results,.....	13·03	
Mean effective pressure as observed, } being the mean result of a series } of diagrams,.....	13·10	
Difference,.....	— 0·07	

being within the limits of errors of observation.

	Bottom. Foot-lbs.	Top. Foot-lbs.
Available heat expended per pound of steam, h ,.....	906989	925678
Pressure in pounds per square inch equivalent to heat, $p_A \div 144$,.....	125	86·4
Mean,.....	105·7	
Efficiency, $\frac{p_m - p_3}{p_A}$,.....	0·121	0·127
Mean, $13·03 \div 105·7$,.....	0·123	

* These are the engines made by Messrs. Randolph, Elder, & Co., for the steamer "Admiral," built by Mr. James R. Napier.

Net feed water per cubic foot swept through by pistons—

$\frac{D_1}{r}$ in pounds,.....	Bottom. 0·0199	Top. 0·0134
---------------------------------	-------------------	----------------

Mean,..... 0·0167

Heat rejected in foot-pounds per pound of steam,..... } 797,437 808,340

Per cubic foot swept through by pistons, 15,830 10,865

Mean,..... 13,347

Injection water required in pounds per cubic foot swept through by pistons, } 0·384
 $T_5 - T_6$ being supposed = 45°,..... }

Available heat expended per hour in foot-pounds per indicated horse-power—

$$\frac{1,980,000}{\text{Efficiency}} = \frac{1,980,000}{0.123} = 16,100,000.$$

The actual consumption of coal was 2·97 lbs. per indicated horse-power per hour; hence the available heat of combustion of 1 lb. of the coal was

$$\frac{16,100,000}{2.97} = 5,420,000 \text{ foot-lbs.};$$

which, if the total heat of combustion of 1 lb. of the coal be estimated at 10,000,000 foot-lbs., gives for the *efficiency of the furnace and boiler*,

$$0.542.$$

Example I., calculated by approximate formulæ:—

DATA— Lbs. per inch.

Mean pressure of admission, $\frac{p_1}{144}$ = 34

Mean back pressure, $\frac{p_3}{144}$ 4

Mean cut off, $\frac{l}{r} = \frac{0.24 + 0.16}{2} = 0.2.$

RESULTS—

Mean gross pressure, $\frac{p_m}{144} = 34 \times .505$ 17·17

Mean effective pressure, $\frac{p_m - p_3}{144}$, calculated..... 13·17

observed,..... 13·10

Difference,..... + 0·07

Pressure equivalent to expenditure of heat, $p_A \div 144$, 105·4

Efficiency, $\frac{p_m - p_3}{p_A} = 0.125.$

Example II.—Engine of 226 indicated horse-power, calculated by exact formulæ:—*

DATA—

	Bottom of cylinder.	Top of cylinder.
Pressure of admission, $\frac{p_1}{144}$,	108½	104
Back pressure, $\frac{p_3}{144}$	3·3	4·0
Ratio of expansion, r ,	16	14
Temperature of feed water T_4 , about 122° Fahrenheit.		

CALCULATED RESULTS—

	Bottom.	Top.
Final volume of 1 lb. of steam, $v_2 = r v_1$,	64·27	58·52
$U_1 - U_2$,	170151	162726
$v_2 (p_2 - p_3)$,	21286	19382
Work of 1 lb. steam, U' ,	191437	182108
Mean effective pressure in pounds per } inch, $\frac{U'}{144 v_2} = \frac{p_m - p_3}{144}$,	20·7	21·6
Mean of both results,	21·15	
Mean observed result of a series of } diagrams,	21·00	
Difference,	+ 0·15	

being within the limits of errors of observation.

	Bottom.	Top.
Heat expended per pound of steam, h ,	975301	966524
Equivalent pressure in pounds per } square inch, $p_A \div 144$,	105	115
Mean,	110	
Efficiency, $\frac{p_m - p_3}{p_A}$	0·196	0·188
Mean,	0·192	

* This is the engine made by Messrs. Rowan & Co. for the "Thetis," built by Messrs. Scott of Greenock.

Example II., calculated by approximate formulæ:—

DATA—

	Lbs. on the square inch.
Mean pressure of admission, $\frac{p_1}{144}$,	106 $\frac{1}{4}$
Back pressure, $\frac{p_3}{144}$,	3·65
Mean cut off, $\frac{1}{r} = \cdot 067 = \frac{1}{15}$.	

RESULTS—

Mean gross pressure, $\frac{P_m}{144} = 106\frac{1}{4} \times \cdot 232$	= 24·6
Mean effective pressure, $\frac{P_m - p_3}{144}$, calculated,	20·95
observed,	21·00
Difference,	<hr style="width: 100%; border: 0; border-top: 1px solid black; margin-bottom: 5px;"/> - 0·05
Pressure equivalent to expenditure of heat } = $p_A \div 144$,	} 110
Efficiency, 0·19.	

The detailed measurements of *one set* out of the series of diagrams from which the power of this engine was ascertained, have already been given in Article 43, page 51. The engine was double cylindered, and the mean effective pressure has reference to the second or larger cylinder, which was *four times* the capacity of the smaller.

	Lbs. on the square inch.
In page 51, there is given as the mean effective pressure in the first or smaller cylinder,	56·0
To reduce this to an equivalent pressure in the second or larger cylinder, divide by 4; then $\frac{56}{4}$ =	14·0
Add the mean effective pressure in the larger cylinder,	7·13
Total reduced mean effective pressure,	<hr style="width: 100%; border: 0; border-top: 1px solid black; margin-bottom: 5px;"/> 21·13

This is the result of one set of diagrams. The mean effective pressure of 21 lbs. on the square inch given in the recent comparisons,

is the mean of the results of several sets of diagrams; and the same is the case with respect to the 226 indicated horse-power.

It may be observed, that in Example I., the exact and the approximate formulæ deviate equally, though in opposite directions, from the result of experiment, and that in Example II. the approximate formula agrees the more closely with experiment of the two. But as the differences in all these cases are much within the limits of those which the errors of observation and the uncertainties of the data are capable of causing, the closeness of the agreement in each case must be considered as partly accidental; and the results of the comparisons between theory and experiment prove simply, that for initial pressures up to about 120 lbs. on the square inch, both the exact and the approximate formulæ agree with experiment closely enough for practical purposes.

Further to illustrate the application of the approximate formulæ, the following tables of examples are given, in which the mean effective pressures, $p_m - p_3$, the pressures equivalent to the expenditure of heat, p_h , the efficiencies of the steam, and the quantities of fuel consumed per indicated horse-power per hour, are computed for a regular series of values of the initial absolute pressure, p_1 , and of the ratio of expansion, r , on the assumption, that the mean absolute back pressure in condensing engines is 4 lbs. on the square inch, and in non-condensing engines, 18 lbs.; and that the available heat of combustion of 1 lb. of the coal employed is 5,400,000 foot-lbs. This value of the available heat per pound of coal has been chosen because of its having been the ascertained value in a number of recent experiments upon marine boilers of ordinary construction and proportions, with good ordinary steam coal. It is easy to modify the numbers in the table to suit any other value of the available heat of combustion. Take, for instance, Example V. for a condensing engine with the admission 0.1 of the stroke. The consumption of coal is stated to be 2.07 lbs. per indicated horse-power per hour, for coal whose available heat of combustion in the furnace and boiler employed is 5,400,000 foot-lbs. But if by using an improved furnace and boiler, and also a better quality of coal, the available heat of combustion can be increased to 10,000,000 foot-lbs. per pound of coal, being greater than the previous amount in the ratio of 100 to 54, and corresponding to an effective evaporative power of 13.4,* then the consumption of coal per indicated horse-power per hour will be reduced to

$$0.54 \times 2.07 = 1.12 \text{ lb.}$$

* This evaporative power was somewhat exceeded in the boiler of the "Thetis," during a short experiment already referred to in Article 284, Example IX., page 297.

TABLE OF EXAMPLES OF CONDENSING STEAM ENGINES WITH DRY SATURATED STEAM,
COMPUTED BY THE APPROXIMATE FORMULÆ.

Back Pressure $p_3 \div 144$, assumed at 4 lbs. on the square inch. Available heat of combustion of 1 lb. of coal, assumed at 5,400,000 ft.-lbs. = an effective evaporative power of 7.24.

Examples.	Ratio of Admission, or effective Cut-off; $\frac{1}{r}$.								
	0.1	0.2	0.3	0.4	0.5	0.6	0.8	1.0	
(1.) $p_1 \div 144 = 20$.									
$(p_m - p_3) \div 144$,.....	8.8	11.1	12.8	14.0	15.5	16.0	
$p_a \div 144$,.....	93	124	155	186	248	310	
Efficiency of steam,.....095	.090	.083	.075	.0625	.052	
lbs. coal per I. H.-P. per hour,....	3.88	4.07	4.42	4.89	5.87	7.04	
(2.) $p_1 \div 144 = 40$.									
$(p_m - p_3) \div 144$,.....	16.2	21.9	26.2	29.6	32.0	35.0	36.0	
$p_a \div 144$,.....	124	186	248	310	372	496	620	
Efficiency of steam,.....131	.118	.106	.095	.086	.071	.058	
lbs. coal per I. H.-P. per hour,....	2.80	3.11	3.46	3.85	4.19	5.15	6.32	
(3.) $p_1 \div 144 = 60$.									
$(p_m - p_3) \div 144$,.....	14.8	26.3	34.9	41.4	46.4	50.0	54.6	56.0	
$p_a \div 144$,.....	93	186	279	372	465	558	744	930	
Efficiency of steam,.....	.159	.140	.125	.111	.100	.090	.073	.060	
lbs. coal per I. H.-P. per hour,....	2.30	2.62	2.93	3.30	3.67	4.07	5.02	6.11	
(4.) $p_1 \div 144 = 80$.									
$(p_m - p_3) \div 144$,.....	21.1	36.4	47.8	56.5	63.2	68.0	74.1	76.0	
$p_a \div 144$,.....	124	248	372	496	620	744	992	1240	
Efficiency of steam,.....	.170	.147	.128	.114	.102	.091	.074	.061	
lbs. coal per I. H.-P. per hour,....	2.14	2.49	2.86	3.21	3.59	4.03	4.95	6.00	
(5.) $p_1 \div 144 = 100$.									
$(p_m - p_3) \div 144$,.....	27.4	46.5	60.8	71.6	80.0	86.0	93.6	96.0	
$p_a \div 144$,.....	155	310	465	620	775	930	1240	1550	
Efficiency of steam,.....	.177	.150	.131	.115	.103	.092	.075	.062	
lbs. coal per I. H.-P. per hour,....	2.07	2.44	2.79	3.19	3.55	3.99	4.89	5.91	

TABLE OF EXAMPLES OF NON-CONDENSING (OR "HIGH-PRESSURE") STEAM ENGINES WITH DRY SATURATED STEAM, COMPUTED BY THE APPROXIMATE FORMULÆ.

Back Pressure $p_3 \div 144$, assumed at 18 lbs. on the square inch. Available heat of combustion of 1 lb. of coal, assumed at 5,400,000 ft.-lbs. = an effective evaporative power of 7.24.

Examples.	Ratio of Admission, or effective Cut-off; $\frac{1}{r}$						
	0.2	0.3	0.4	0.5	0.6	0.8	1.0
(6.) $p_1 \div 144 = 60$.							
$(p_m - p_3) \div 144$,.....	27.4	32.4	36.0	40.6	42.0
$p_A \div 144$,.....	37.2	46.5	55.8	74.4	93.0
Efficiency of steam,.....074	.070	.064	.055	.045
lbs. coal per I. H.-P. per hour,.....	4.91	5.24	5.72	6.67	8.15
(7.) $p_1 \div 144 = 80$.							
$(p_m - p_3) \div 144$,.....	33.8	42.5	49.2	54.0	60.1	62.0
$p_A \div 144$,.....	37.2	49.6	62.0	74.4	99.2	124.0
Efficiency of steam,.....091	.086	.080	.073	.061	.050
lbs. coal per I. H.-P. per hour,.....	4.03	4.26	4.58	5.02	6.01	7.33
(8.) $p_1 \div 144 = 100$.							
$(p_m - p_3) \div 144$,.....	32.5	46.8	57.6	66.0	72.0	79.6	82.0
$p_A \div 144$,.....	31.0	46.5	62.0	77.5	93.0	124.0	155.0
Efficiency of steam,.....	.105	.100	.093	.085	.077	.064	.053
lbs. coal per I. H.-P. per hour,.....	3.49	3.67	3.94	4.31	4.76	5.72	6.90
(9.) $p_1 \div 144 = 120$.							
$(p_m - p_3) \div 144$,.....	42.6	59.8	72.8	82.8	90.0	99.2	102.0
$p_A \div 144$,.....	37.2	55.8	74.4	93.0	111.6	148.8	186.0
Efficiency of steam,.....	.115	.107	.098	.089	.081	.067	.055
lbs. coal per I. H.-P. per hour,.....	3.19	3.42	3.73	4.11	4.52	5.47	6.67
(10.) $p_1 \div 144 = 160$.							
$(p_m - p_3) \div 144$,.....	62.8	85.6	103.0	116.4	126.0	138.2	142.0
$p_A \div 144$,.....	49.6	74.8	99.2	124.0	148.8	198.4	248.0
Efficiency of steam,.....	.127	.115	.104	.094	.085	.070	.057
lbs. coal per I. H.-P. per hour,.....	2.89	3.19	3.52	3.89	4.31	5.24	6.42

289 A. **Condensing High Pressure Engines.**—This term may be applied to engines such as Mr. Beattie's locomotives, in which, although the steam is discharged from the cylinder at, or a little above, the atmospheric pressure, a portion of it is condensed for the purpose of heating the feed water, the remainder being used to make a blast in the chimney. This is effected by conducting steam through a branch from the exhaust pipe into a close vessel, through which there falls a shower of water from the water tank. From the bottom of that vessel water is drawn by the feed pump, and forced into the boiler, its temperature being usually about 200° Fahrenheit.

In applying the exact formulæ to this case, T_4 is to be made = 200° Fahrenheit, or whatever other temperature the feed water may have.

In applying the approximate formulæ, the results of the following calculation will in general be found sufficiently accurate.

The approximate expression already given for the expenditure of heat per unit of volume swept through by the piston, viz., $\frac{15\frac{1}{2} p_1}{r}$, was obtained upon the supposition of the temperature of the feed water being 104°, or thereabouts. Referring to Article 215 A, and to the Table in page 256, let f denote the "factor of evaporation" for the boiling point of the water in the boiler, and for the temperature of feed water 104°; and let f' be the factor of evaporation for the same boiling point, and for the temperature of feed water 200°; then the expenditure of heat will be reduced very nearly in the proportion $\frac{f'}{f}$, so that the approximate formula for the expenditure of heat per unit of volume swept through by the piston will now be

$$\frac{H_1}{r v_1} = \frac{f'}{f} \cdot \frac{15\frac{1}{2} p_1}{r} \dots\dots\dots(1.)$$

For example, let the boiling point be 320° Fahrenheit, which corresponds to a pressure of 89.86 lbs. on the square inch in all, or 75 lbs. above the atmosphere nearly; then

$$f' = 1.04; f = 1.15; \text{ and}$$

$$\frac{H_1}{r v_1} = \frac{14}{r} p_1 \text{ nearly} \dots\dots\dots(2.)$$

The pipe for conducting steam from the exhaust pipe to the condenser has a cock or valve, by means of which its opening is adjusted until it transmits the greatest quantity of steam com-

patible with complete, or nearly complete, condensation. According to experiments on Mr. Beattie's engines described by Mr. Patrick Stirling, about *one-fourth* of the whole exhaust steam is required for this purpose; and the remaining three-fourths are adequate to produce a sufficient blast in the chimney.

290. **Difference between Pressure in Boiler, and Initial Pressure in Cylinder.—Wire-Drawn Steam.**—The fall which the pressure of the steam undergoes during its passage from the boiler to the cylinder, is due to the following causes:—

1. The resistance of the steam pipe through which the steam passes from the boiler to the valve box.

2. The resistance of the regulator, or throttle valve, by which the steam pipe is partially closed, in the same manner with the supply pipe of the water pressure engine, fig. 40, Article 132, page 140.

3. The resistance of the "*ports*," or steam passages through which the steam is admitted from the valve box into the cylinder, and which are at times partially closed by the valves, so as to have their resistance increased.

4. The disappearance of actual energy when the steam passes from the ports into the cylinder, exchanging its previous rapid motion for the comparatively slow motion of the piston.

It is impossible, in the present state of our knowledge of the properties of steam, to calculate separately the losses of pressure due to these four causes; and even were it possible, the complexity of the resulting formula would be out of proportion to its practical utility. All that can for the present be done is to use the theory of the discharge of gases through orifices, as explained in Article 254, in order to find the probable *form* of an approximate formula for the whole loss of pressure, and to determine a constant co-efficient in that formula empirically from experiments on existing engines.

The best collection of experimental data on this subject is contained in Mr. D. K. Clark's work on *Railway Machinery*. These data are taken partly from the experiments of Messrs. Gouin and Lechatelier, and partly from Mr. Clark's own experiments; and are to a certain extent reduced to general laws.

Amongst other general results, Mr. Clark finds that the effect of the resistance in the steam pipe is inappreciable, when the sectional area of that pipe is not less than $\frac{1}{16}$ of the area of the piston for steam in an ordinary state as to dryness, and not less than $\frac{1}{8}$ for steam in a very dry state; the mean speed of the piston not exceeding 600 feet per minute, or 10 feet per second. It follows, that in a well constructed engine, the steam pipe should be so proportioned, that supposing the density of the steam to be

the same in it and in the cylinder, the velocity of the steam through the steam pipe shall not exceed about 100 feet per second, and then the resistance in the pipe may be neglected. This result is corroborated by the known effect in practice of the ordinary rule, that where the velocity of the piston is from 200 to 240 feet per second, the area of the steam pipe should be about $\frac{1}{4}$ of that of the piston.

The resistance of the regulator in a properly proportioned steam pipe is inappreciable when it is wide open; and when it is partially closed, the investigation of mathematical relations between the resistance and the opening is practically unimportant, because the extent of opening of the regulator required to produce any given reduction of pressure in any existing engine can easily be found by trial.

There remain to be considered, the resistance of the cylinder ports, and the loss of head on entering the cylinder.

In Article 254, equation 1, is given an expression for the velocity of a gas rushing through an orifice, from a space in which the pressure is p_1 , into a space in which the pressure is p_2 . To prevent confusion, and to adapt the equation to the notation of the present section,

Put p_b to stand for the pressure in the boiler and valve chest, instead of p_1 ;

And p_1 , the initial pressure in the cylinder, instead of p_2 ;

Also put V instead of u to denote the greatest velocity of flow.

Square both sides of the equation; divide by $2g$; and for $\frac{\gamma}{\gamma-1} \cdot \frac{p_0 v_0}{\tau_0}$ substitute its equivalent, K_p ; then we have for the head due to the maximum velocity V —

$$\frac{V^2}{2g} = K_p \tau_1 \left\{ 1 - \left(\frac{p_1}{p_b} \right)^{\frac{\gamma-1}{\gamma}} \right\};$$

which for steam, treated as a perfect gas, becomes

$$\frac{V^2}{2g} = 366.7 \tau_1 \left\{ 1 - \left(\frac{p_1}{p_b} \right)^{0.233} \right\} \dots\dots\dots (1.)$$

From analogy with the flow of liquids and of air, it is probable that when besides producing a current of steam of a certain velocity, the difference of pressure has also to overcome the friction of a passage, the left-hand side of the preceding equation should be multiplied by $1 + F$, F being a "factor of resistance" (as in Article 99).

The quantity V^2 , being the mean square of the velocity with

which the steam enters the cylinder, may be treated as the product of three factors, viz :—

The square of the mean velocity of the piston (let this be denoted by V^2);

The square of the ratio in which the area of the piston exceeds the area of the port $\left(\frac{A^2}{a^2}\right)$;

A factor depending on the figure and manner of motion of the valve.

For simplicity's sake, take the product of this last factor, and of the factor $1 + F$, which may be denoted by one symbol, B. Then the formula for the "loss of head" sustained by the steam becomes

$$\frac{B V^2 A^2}{2 g a^2} = 366.7 \tau_1 \left\{ 1 - \left(\frac{p_1}{p_b} \right)^{0.233} \right\}; \dots\dots\dots(2.)$$

giving the following formula for computing the ratio in which the absolute pressure of the steam falls :—

$$\frac{p_1}{p_b} = \left\{ 1 - \frac{B V^2 A^2}{2 g \times 366.7 \tau_1 a^2} \right\}^{4.29} \dots\dots\dots(3.)$$

The co-efficient, B, is to be determined empirically. As a basis for this determination in the case of dry steam may be taken one of the general conclusions arrived at by Mr. Clark, viz, that when $\frac{A}{a} = 15$, and $V = 10$ feet per second, $\frac{p_1}{p_b} = 0.84$ nearly; the pressure in the valve chest, p_b , being on an average 90 lbs. on the square inch or thereabouts, and consequently the absolute temperature $\tau_1 = 320^\circ + 461^\circ.2 = 781^\circ.2$ nearly.

These data give $B = 32.4$, and consequently

$$\frac{B}{2 g \times 366.7} = \frac{32.4}{23615.5} = \frac{1}{726};$$

so that equation 3 becomes

$$\frac{p_1}{p_b} = \left\{ 1 - \frac{V^2 A^2}{726 \tau_1 a^2} \right\}^{4.29} \dots\dots\dots(4.)$$

In all cases in which the difference between p_b and p_1 is small, the following formula is a sufficiently close approximation :—

$$\frac{p_1}{p_b} = 1 - \frac{V^2 A^2}{180 \tau_1 a^2}; \dots\dots\dots(5.)$$

The following example is a case to which the approximate formula does *not* apply. The data are such as are sometimes met with in Cornish single acting engines:—

$$V' = 2\frac{1}{2} \text{ feet per second; } \frac{A}{a} = 120;$$

$$\tau_1 = 745.2; \text{ whence}$$

$$\frac{p_1}{p_0} = 0.8336^{4.29} = 0.458;$$

so that if $p_0 = 52.52$ lbs. per square inch, $p_1 = 24$ lbs. on the square inch.

In the next example, the approximate formula is applicable; and the data are such as are very commonly met with in double acting expansive engines.

$$V' = 4 \text{ feet per second; } \frac{A}{a} = 25;$$

$$\tau_1 = 266^\circ + 461^\circ.2 = 727^\circ.2; \text{ whence, by equation 5,}$$

$$\frac{p_1}{p_0} = 1 - \frac{10000}{130896} = 1 - 0.0764 = 0.9236;$$

so that if $p_0 = 39.2$ lbs. on the square inch, $p_1 = 36.2$ lbs. on the square inch, the loss of pressure being 3 lbs. on the square inch.

It appears further, from the experiments of Mr. Clark, that the loss of pressure of misty steam in traversing passages exceeds that of dry steam in a proportion which cannot be computed with any approach to precision, but which ranges from $1\frac{1}{4}$ to $2\frac{1}{2}$ and sometimes even to 3.

The *loss of head* which occurs during the passage of steam from the boiler to the cylinder, does not wholly represent *wasted energy*; for being expended in friction, it produces heat; so that steam which has had its pressure lowered by the resistance of passages, or as it is called, has been *WIRE-DRAWN*, is *superheated* (that is, is at a temperature higher than the boiling point corresponding to its pressure, although lower than the temperature in the boiler), as has already been stated in Article 253. Even supposing, however, that no energy is directly wasted when steam is wire-drawn, there is still an indirect waste of energy from the lowering of its pressure, which, by diminishing the forward pressure upon the piston as compared with the back pressure, and by diminishing the extent of expansive working of which the steam is capable, lowers its efficiency.

When an engine, therefore, has to work against a diminished

resistance, it is better to diminish the mean effective pressure by cutting off the admission earlier, and so working with a greater ratio of expansion, than by contracting the opening of the regulator, and so lowering the initial pressure by wire-drawing. The former method makes the engine more economical, the latter less.

291. **Effects of Disturbing Causes on Diagrams.**—Some of the deviations of the diagram of energy of a steam engine from the ideal form have already been considered incidentally in the preceding Articles of this section. In the present Article the more important and usual of these deviations are to be classed and considered more in detail.

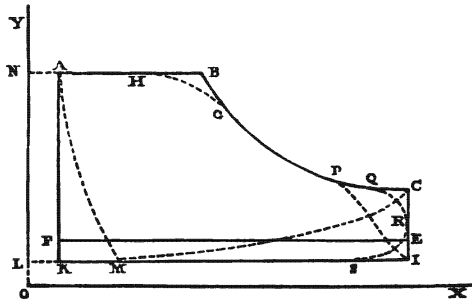

Fig. 111.

These causes may be thus classed,—

Causes which affect the power of the engine, as well as the figure of the diagram:—

- I. Wire-drawing at cut-off.
- II. Clearance.
- III. Compression, or cushioning.
- IV. Release.
- V. Conduction of heat.
- VI. Liquid water in the cylinder.

Causes which affect the figure of the diagram only:—

- VII. Undulations.
- VIII. Friction of the indicator.
- IX. Position of the indicator.

I. *Wire-drawing at Cut-off.*—The valve by which the steam is admitted into one end of the cylinder, closes, in order to cut off the admission of steam, not instantaneously, but by degrees, especially when it is a slide valve. In consequence of this, the loss of pressure by the steam in passing from the valve chest into the cylinder gradually increases, and the pressure of the steam in the cylinder begins gradually to diminish, before the complete closing of the valve; so that the top of the diagram, which is

drawn during the admission of the steam, instead of presenting a straight line, A B (fig. 111), parallel to O X, presents a drooping curve, convex upwards, such as A H G.

The point of the stroke where the *complete closing* of the valve, or *actual cut-off*, takes place, is usually marked on the diagram by a *point of contrary flexure*, G, where the curve convex upwards, H G, produced by wire-drawing, touches the curve of expansion, G C, which is concave upwards. The steam begins to a certain extent to work expansively before the valve is completely closed, and the energy exerted is nearly the same as if the valve closed instantaneously at a somewhat earlier point of the stroke, which may be called the *virtual*, or *effective cut-off*. To find approximately that point, produce the expansion curve, C G, upwards, and draw the straight line, A B, to meet it; then the point B marks the effective cut-off, and determines the effective ratio of expansion to be used in computing the efficiency.

II. *Clearance* is a term used to include, not merely the clearance proper, which is the space between the piston and the end of the cylinder to which it is nearest at the end or beginning of a stroke, but also the volume of the ports, and generally the whole *minimum* space between the piston and the valves. It is evident that this space, as well as the space through which the piston sweeps, has to be filled with steam.

The clearance, for purposes of calculation, is expressed in the form of a fraction of the space swept through by the piston during a single stroke. Let A be the area of the piston, *s* the length of its stroke; then

$$\frac{\text{volume of clearance}}{A s} = c \dots \dots \dots (1.)$$

is the fraction in question, and

$$\text{volume of clearance} = c A s \dots \dots \dots (2.)$$

The *length of cylinder equivalent to the clearance* is

$$\frac{\text{volume of clearance}}{A} = c s \dots \dots \dots (3.)$$

The value of the fraction *c* ranges from $\frac{1}{4}$ to $\frac{1}{16}$, and sometimes less, in different engines, being greatest in the smallest engines. The equivalent length of cylinder *c s* varies less, being usually from one to two inches.

The clearance affects the ratio of expansion in the following manner:—

In fig. 111, let $\overline{E F} = A s$ represent the whole space swept

through by the piston per stroke; and let $\overline{L K} = \overline{N A} = c A s$ represent the clearance. The steam being cut off at B, $\overline{A B}$ in the diagram A B C E F A appears to represent the volume of steam in the cylinder at the instant of cut-off, and

$$\frac{\overline{A B}}{\overline{E F}} = \frac{1}{r'}, \quad \frac{\overline{E F}}{\overline{A B}} = r',$$

are the apparent cut-off and ratio of expansion. But the real volume of steam in the cylinder at the instant of cut-off is $\overline{N B}$, and it expands to the volume $\overline{L I}$; so that the *real* cut-off and ratio of expansion are

$$\frac{1}{r} = \frac{\overline{N B}}{\overline{L I}} = \frac{\frac{1}{r'} + c}{1 + c}; \quad r = \frac{\overline{L I}}{\overline{N B}} = \frac{1 + c}{\frac{1}{r'} + c} = \frac{r' + c r'}{1 + c r'} \dots (4.)$$

If the steam is completely exhausted from the cylinder during each return stroke, the clearance produces the following effect on the expenditure of steam and of heat. The *apparent* volume of steam admitted per stroke being $\overline{A B}$, and the *real* volume $\overline{N B}$, the expenditure of steam, and consequently of heat, is increased by reason of the clearance in the ratio

$$\frac{\overline{N B}}{\overline{A B}} = 1 + c r' \dots \dots \dots (5.)$$

On the same supposition, that the steam is completely exhausted during each return stroke, the *energy exerted on the piston per pound of steam* is diminished nearly, but not quite, by the amount

$$v_1 (p_1 - p_3) : \frac{c r'}{1 + c r'} \dots \dots \dots (6.)$$

v_1 being, as usual, the volume of one pound of steam when admitted, p_1 the pressure of admission, and p_3 the mean back pressure. The diminution of energy exerted is *not quite* to the above amount; because the energy with which the steam rushes in to fill the clearance is expended partly in impulse against the piston, and partly in producing heat by friction amongst the particles of steam, and that heat superheats the steam, and makes a less quantity suffice to fill a given space at a given pressure.

If the whole of the energy per pound of steam denoted by the expression 6 were lost, it would reduce the *efficiency of the steam* in the proportion of

$$1 - \frac{c r'}{1 + c r'} \cdot \frac{p_1 - p_3}{r (p_m - p_3)} : 1 \dots\dots\dots(7.)$$

III. *Compression, or cushioning*, is effected by closing the education valve before the end of the return stroke; for example, at the point corresponding to M on the diagram. This confines a certain quantity of steam in the cylinder, which is compressed by the piston during the remainder of the return stroke, the rise of its pressure being represented by some such curve as M A. In the figure, that curve is made to terminate at A, in order to represent the *most advantageous adjustment* of the compression, which takes place when the quantity of steam confined or "cushioned" is *just sufficient to fill the clearance at the initial pressure* p_1 .

An approximate formula for adjusting the compression is as follows:—

$$\frac{\overline{KM}}{\overline{KI}} = c r' \cdot \left(\frac{p_3}{p_1}\right)^{\frac{9}{10}} \dots\dots\dots(8.)$$

The effect of this adjustment is to save all the additional expenditure of steam per stroke denoted by $c r'$ in equation 5, and to save also the loss of energy per pound of steam expressed by the formula 6; so that the *efficiency of the steam* remains undiminished. The *mean effective pressure*, however, is diminished in the proportion

$$1 : 1 + c r';$$

and the *pressure equivalent to the heat expended* in the same proportion; so that if $p_m - p_3$ and p_h respectively represent those quantities, calculated, as in previous Articles, on the supposition of there being no clearance, they are altered respectively to

$$\frac{p_m - p_3}{1 + c r'} \text{ and } \frac{p_h}{1 + c r'}; \dots\dots\dots(9.)$$

while the *space to be swept through by the piston per minute, per indicated horse-power*, is at the same time *increased* in the ratio

$$1 + c r' : 1,$$

and becomes

$$\frac{33000 (1 + c r')}{p_m - p_3} \text{ in cubic feet,} \dots\dots\dots(10.)$$

when the pressures are expressed in pounds on the square foot.

In the case which has now been considered of adjusted cushioning, the fraction $\frac{c r'}{1 + c r'}$ of a whole cylinderful of steam (clearance

included), performs the part of a cushion according to the principles laid down for heat engines in general in Article 262, while the

fraction $\frac{1}{1+c'}$ performs the effective work.

IV. *Release* means opening the exhaust port for the escape of the steam before the forward stroke is finished, in order to diminish the back pressure. In an engine in which there is no release (the exhaust port opening exactly at the end of the forward stroke), the diagram during the return stroke is usually a curve more or less resembling the dotted line C M K; the lower side of the ideal diagram used in calculation being a straight line E F, so placed that its constant ordinate p_3 is equal to the mean ordinate of the curve. L K I is a straight line, whose ordinate O L represents the pressure in the condenser (or in non-condensing engines, the atmospheric pressure). By making the release occur early enough, for example, at the point corresponding to P in the diagram, the entire fall of pressure may be made to take place towards the end of the forward stroke, so as to make the back pressure coincide sensibly with that corresponding to the ordinate of K I; and then the end of the diagram will assume a figure represented by the dotted line P I, which is usually more or less concave upwards. Energy will be saved to the amount represented by the rectangle $\overline{K F} \times \overline{K I}$, and energy lost to the amount represented by the area of the figure P C I P; and on the whole, energy will be saved or lost according as the former or the latter of those areas is the larger. The greatest saving of energy is insured by making the release take place at a point Q such, that about one-half of the fall of pressure shall take place at the end of the forward stroke, and the other half at the commencement of the return stroke, as indicated by the dotted curve Q R S.

V. *Conduction of heat to and from the metal of the cylinder*, or

VI. *To and from liquid water contained in the cylinder*, has the effect of lowering the pressure at the beginning, and raising it at the end of the stroke, in the manner already mentioned incidentally in Article 286, the lowering effect being on the whole greater than the raising effect. The general nature of the change thus produced in the diagram is shown by the dotted line G H I C F in fig. 112. The effect of liquid water is much greater than that of the metal of the cylinder, and is augmented by the increased resistance which it produces to the flow of the steam through the ports (already mentioned in Article 290), which not only diminishes the pressure of admission, but increases the back pressure (see as to this, Article 280). The remedy for these evils, by heating the cylinder externally, has already been mentioned in Article 290.

VII. *Undulations*, such as those sketched in fig. 113, are caused partly by the inertia of the indicator piston, and the elasticity of

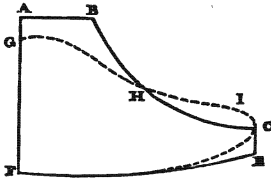

Fig. 112.

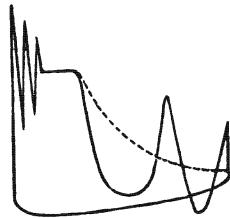

Fig. 113.

its springs, and partly by pulsations, like waves of sound, in the steam. When large and extensive, they make it extremely difficult to determine the mean effective pressure from the diagram. In attempting to find that pressure, by sketching a diagram freed from undulations, it is more accurate to draw a line, such as the dotted line in the figure, *midway between the crests and hollows* of the waves, than to draw a line enclosing the same area with the wavy line.

VIII. *The friction of the indicator*, by directly opposing the motion of its piston and pencil, tends to make the indicated forward pressure less, and the indicated back pressure greater, than the real forward and back pressure respectively, and so to make the indicated energy less than the real energy exerted by the steam on the piston; but to what extent is very uncertain. According to some experiments by Mr. Hirn (*Bulletin de Mulhouse*, vols. xxvii., xxviii.), the diminution of the indicated energy by the friction of the indicator agrees nearly with the work performed in overcoming the friction of the steam engine; so that the indicator shows, not the whole energy exerted by the steam on the piston, but very nearly the *useful work* of the steam engine; but it is doubtful how far this principle is generally applicable; and other experiments, especially those on screw steamers, are at variance with it.

IX. *Position of Indicator*.—Experiments by Messrs. Randolph, Elder, & Co., have proved what might have been expected from the laws of fluid motion, that when a rapid current of steam blows *across* the orifice of the nozzle of an indicator, the indicated pressure is less than the real pressure. Every indicator, therefore, should be fixed, if possible, in a position where it is not exposed to this cause of error.

292. **Resistance of Engine — Efficiency of Mechanism.** — The energy lost through the resistance of the engine comprehends that

expended in overcoming the friction of the mechanism, in working the feed pump, in working the air pump and cold water pump of condensing engines, and generally, in overcoming all resistances arising within the engine itself, except the back pressure of the steam.

Our knowledge of the amount of energy so lost is still very vague and indefinite. The formula (originally proposed by the Count de Pambour), by which it is calculated approximately, is of the following kind:—

Let R_1 represent the *useful load* of the engine, reduced by the principle of virtual velocities to the piston as the driving point, as in Article 264. Then the prejudicial resistance, reduced to the piston also, probably consists of a constant part, which is the resistance of the engine when unloaded, and of a part increasing in proportion to the useful load; so that the *total resistance*, reduced to the piston, may be expressed in the following form:—

$$R = (1 + f) R_1 + R_0; \dots \dots \dots (1.)$$

R_0 being the resistance unloaded, and f the co-efficient for the variable part of the resistance.

Let A be the area of the piston; then the total resistance, *per unit of area of piston*, which is equal to the mean effective pressure, may be thus expressed:—

$$p_m - p_3 = \frac{R}{A} = (1 + f) \frac{R_1}{A} + \frac{R_0}{A} \dots \dots \dots (2.)$$

The *efficiency of the mechanism* is given by the formula,

$$\frac{R_1}{R} = \frac{R_1}{A (p_m - p_3)} = \frac{1}{1 + f + \frac{R_0}{R_1}}; \dots \dots \dots (3.)$$

and this, being multiplied by the *efficiency of the steam*, and by the *efficiency of the furnace*, gives the *resultant efficiency* of the whole steam engine.

The unloaded resistance is known by experiment to range from $\frac{1}{2}$ lb. to about $1\frac{1}{2}$ lb. per square inch of piston (being greatest proportionally in the smallest engines), and to be on an average 1 lb. per square inch; hence we may put, approximately,

$$\frac{R_0}{A} = 1 \text{ lb. on the square inch} = 144 \text{ lbs. on the square foot} \dots (4.)$$

The value of f in well made engines in the best order is estimated

by the Count de Pambour at $\frac{1}{7} = 0.143$; and that estimate is corroborated by general experience, in cases in which there is no special cause for increased friction. In such cases, then, we may put for the gross resistance, in pounds,

$$R = 1\frac{1}{7} R_1 + A \text{ in square inches;.....(5.)}$$

and for the efficiency of the mechanism,

$$\frac{R_1}{R} = \frac{R_1}{A(p_m - p_s)} = \frac{1}{1.143 + \frac{A \text{ in inches}}{R_1}} \text{.....(6.)}$$

In most cases which occur in practice, a result nearly agreeing with that of the preceding formula is obtained by supposing the whole of the prejudicial resistance to be proportional to the useful load; that is, by making

$$R = (1 + f') R_1; \text{.....(7.)}$$

so that the efficiency of the mechanism is

$$\frac{R_1}{R} = \frac{1}{1 + f'} \text{.....(8.)}$$

the value of f' being somewhere between 0.2 and 0.25, and that of $1 + f'$ between $\frac{3}{2}$ and $\frac{5}{4}$.

293. Action of Steam against a known Resistance—Pambour's Problem.—The nature of the problem now to be considered with special reference to the action of saturated steam, has already been stated in general terms in Article 264. It was first solved by the Count de Pambour. In that author's solution, however, the *weight of steam* produced in the boiler in a given time was treated as a known constant quantity; while in this treatise, it is the *available heat* of the furnace in a given time that will be treated as a known constant quantity; the problem being, when that quantity, and the *useful resistance to be overcome by the engine*, and the *back pressure*, and also the *ratio of expansion* are given, to find the *mean velocity with which the piston will move*.

Let R_1 be the useful resistance, reduced to the piston. Then the total resistance, as explained in Article 292, is

$$R = (1 + f) R_1 + R_0 \text{.....(1.)}$$

Divide this by the area of the piston or pistons, in a single cylinder engine, or by the area of the larger piston or pistons, in a double cylinder engine; then

$$\frac{R}{A} \dots\dots\dots(2.)$$

is the mean effective pressure.

Let r' be the apparent ratio of expansion, c the clearance, then, as in Article 291, Division II., we have for the real ratio of expansion,

$$r = \frac{r' + cr'}{1 + c} \dots\dots\dots(3.)$$

Let the cushioning be adjusted as it ought to be so as to prevent appreciable loss of efficiency by clearance; then, as in Article 291, Division III., we have for the *mean effective pressure* in an *ideal diagram*, freed from the effect of the cushioning,

$$\left. \begin{aligned} p_m - p_3 &= \frac{R}{(1 + cr')A}; \\ p_m &= \frac{R}{(1 + cr')A} + p_3 \end{aligned} \right\} \dots\dots\dots(4.)$$

From the real ratio of expansion r find, by the approximate formulæ of Article 285, or Table VII., if the cylinder is unjacketed, or by the approximate formulæ of Article 288, or Table VIII., if the cylinder is jacketed, the ratio

$$\frac{p_1}{p_m};$$

then the *initial pressure of the steam* will be

$$p_1 = \frac{p_1}{p_m} \cdot \left(\frac{R}{(1 + cr')A} + p_3 \right); \dots\dots\dots(5.)$$

and the speed of the engine will adjust itself so as to maintain this pressure.

From the initial pressure, by the proper exact formulæ of Article 284 or 287, or approximate formulæ of Article 285 or 288, as the case may be, compute the *pressure equivalent to the expenditure of heat*,

$$p_h = \frac{H_1}{r v_1} = \frac{p_1}{\text{efficiency of steam}}; \dots\dots\dots(6.)$$

Let W be the number of lbs. of coal burned *per minute*; h the available heat of combustion of one lb. of coal in foot-lbs.; then the *volume which the piston will sweep through effectively per minute* will be

$$N A s = (1 + c r') \frac{h W}{p_A}; \dots\dots\dots(7.)$$

s being the length of stroke, A the area of piston, and N the number of revolutions per minute, or the double of that number, according as the engine is single or double-acting. This volume being divided by A gives the *distance* moved through effectively by the piston per minute (the back strokes not being reckoned in a single acting engine), viz.,

$$N s = (1 + c r') \frac{h W}{p_A A}; \dots\dots\dots(8.)$$

being the solution of the problem.

The *indicated power*, in foot-lbs. per minute, is

$$\frac{N A s (p_m - p_3)}{1 + c r'} = N s R; \dots\dots\dots(9.)$$

and the *effective power*

$$\frac{N A s \left\{ \frac{p_m - p_3}{1 + c r'} - \frac{R_0}{A} \right\}}{1 + f} = N s R_1; \dots\dots\dots(10.)$$

and these quantities are reduced to *horse-power*, by dividing by 33,000.

When the effect of clearance is inappreciable (as is often the case in practice), the preceding formulæ are simplified by making $c = 0$. This is the case in the double-acting engine from which the following example is taken; being the same engine which has already been referred to in Example I. of Article 289.

DATA.

Resistance overcome at circumference of wheels, making one turn per double stroke,.....	}	12900 lbs.
Circumference,		
Length of stroke of piston,.....		$s = 4.25$ „
Joint area of large pistons, $A = 9192$ square inches; f estimated $= \frac{1}{7}$; $\frac{R_0}{A} = 1$ lb. per square inch.		
Back pressure, $p_3 = 4$ lbs. on the square inch.		
Weight of coal burned per minute,.....		$W = 36.8$ lbs.
Available heat of combustion of 1 lb. of coal,.....	}	$h = 5,400,000$ foot-lbs.

RESULTS.

$$\frac{\text{Circumference of wheels}}{\text{Double stroke}} = \frac{64.4}{8.5} \text{ therefore,}$$

$$R_1 = 12900 \times \frac{64.4}{8.5} = 97736 \text{ lbs.}$$

$$\frac{R_1}{A} = \frac{97736}{9192} = 10.63 \text{ lbs. per square inch.}$$

$$p_m - p_s = 1\frac{1}{2} \times 10.63 + 1 = 13.15 \text{ lbs. per square inch.}$$

$$p_m = 13.15 + 4.00 = 17.15 \text{ lbs. per square inch.}$$

$$\frac{p_1}{p_m} \text{ by Table VIII. (for } \frac{1}{r} = 0.2) 1.98.$$

$$\text{Initial pressure } p_1 = 17.15 \times 1.98 = 33.96 \text{ lbs. per square inch.}$$

$$p_a \text{ by approximate formula} = \frac{15\frac{1}{2} \times 33.96}{5} = 105.3.$$

$$A p_a = 105.3 \times 9192 = 967,918 \text{ lbs.}$$

$$h W = 5,400,000 \times 36.8 = 198,720,000 \text{ foot-lbs.}$$

Mean velocity of pistons—

$$\frac{h W}{A p_a} = \frac{198,720,000}{967,918} = 205.3 \text{ feet per minute;}$$

the actual mean velocity of the pistons was 204 feet per minute.

Indicated horse-power, from calculated speed of piston—

$$\frac{205.3 \times 13.15 \times 9192}{33,000} = 752.$$

The indicated horse-power as observed,..... 744.

Effective horse-power from calculated speed of piston—

$$\frac{205.3 \times 97736}{33000} = 608.$$

Effective horse-power from observed speed—

$$\frac{204 \times 97736}{33000} = 604.$$

294. **Customary Mode of Stating Pressures.**—The customary mode of stating pressures, already described in Article 105, as

applied to pressures of water, is also applied to pressures of steam; that is to say, the pressure is stated, as it is shown by a gauge or indicator, in *pounds per square inch above or below the atmospheric pressure*; a pressure lower than the atmospheric pressure being treated as negative, and called "*vacuum*." Pressures stated in this customary manner are reduced to real or absolute pressures by adding them to the atmospheric pressure if positive, and subtracting them from the atmospheric pressure if negative. During experiments on steam engines intended to serve as a basis for exact calculations of efficiency, the atmospheric pressure ought to be observed from time to time by means of a barometer. When it has not been so observed, it may be guessed at 14·7 lbs. on the square inch, at the level of the sea. As to its diminution at higher levels, see Article 106.

To illustrate this by an example, suppose that the atmospheric pressure, during a given experiment, is actually 14·7 lbs. on the square inch; and that the pressure in the boiler, the initial pressure and mean back pressure in the cylinder, and the pressure in the condenser, are shown by the indicator and gauges, and described in customary language, as follows:—

Pressure in boiler,	23 lbs. on the square inch.		
Initial pressure in cylinder,	19	"	"
Mean vacuum in cylinder,	10·7	"	"
Vacuum in condenser,	12·7	"	"

Then the real or *absolute* values of these pressures are—

Pressure in boiler, $p_0 = 14\cdot7 + 23 = 37\cdot7$	lbs. on the square inch.		
Initial pressure in cylinder, ... } $p_1 = 14\cdot7 + 19 = 33\cdot7$		"	"
Mean back pressure,	$p_3 = 14\cdot7 - 10\cdot7 = 4$	"	"
Pressure in condenser,	$14\cdot7 - 12\cdot7 = 2$	"	"

The vacuum in the condenser being often measured by a mercurial gauge, is sometimes stated in *inches of mercury*. As to the reduction of inches of mercury to lbs. on the square inch, see Article 107.

SECTION 6.—On the Action of Superheated Steam.

295. **Objects and Methods of Superheating Steam.**—The principal objects of heating steam to a temperature above the boiling point corresponding to its pressure are the following:—

I. To raise the temperature at which the fluid receives heat, and

so to increase the efficiency of the fluid (according to the principle of Article 265); and that without producing a dangerous pressure.

II. To diminish the density of the steam employed to overcome a given resistance, and so to lessen the back pressure, according to one of the principles stated in Article 280; in customary phrase, "to improve the vacuum."

III. To prevent condensation of the steam during its expansion, without the aid of a jacket.

Those three effects all tend to increase the efficiency of the fluid, and economize fuel.

The principal methods of superheating steam are the following:—

I. *Wire-drawing*, as explained in Article 290, which occasions superheating when the pressure in the cylinder is much less than that in the boiler; but seldom to an extent whose effects can be made the subject of calculation. Superheating in this way takes place more by accident than design, and does not secure all the advantages just ascribed to superheating; for although the steam in the cylinder is at a temperature higher than the boiling point corresponding to its pressure, the steam in the boiler is at a higher temperature still, and at the pressure of saturation corresponding to that higher temperature.

II. *Superheating by the steam jacket*, which takes place when the steam jacket communicates more heat to the expanding steam in the cylinder than is necessary merely to prevent any of it from condensing. It does not appear that this kind of superheating produces an effect that can be made the subject of a definite calculation. Its extent is limited, as in Method I., by the temperature in the boiler.

III. *Superheating in the steam chest*, or upper part of the boiler, by means of flues traversing or surrounding it. By this method, the steam may be raised to a temperature somewhat, but not very much exceeding the boiling point corresponding to the pressure in the boiler. This is practised in many marine engines, and in some cases with the effect of preventing condensation in unjacketed cylinders.

IV. *Superheating in tubes or passages* which the steam traverses on its way from the boiler to the cylinder. By this method almost any required temperature can be given to steam of any pressure. It is difficult, if not impossible, to specify any one as the first inventor of this process. Mr. Frost was at all events one of the first to recommend it and cause it to be put in practice. It was used many years ago in the engines of the American mail steamer "Arctic" with good effect, and has since been used by many makers in many engines, chiefly marine, with a great variety of forms of apparatus, some of which will be described in Chap. IV.

V. *Superheating by mixture*, where a portion only of the steam is passed through superheating tubes, and raised to a very high temperature, and then injected amongst the remainder of the steam at or near the cylinder ports, so as to bring the whole mass of steam to a temperature intermediate between the boiling point corresponding to its pressure, and the temperature in the superheating tubes. The mixture thus made is called by the Hon. John Wethered, who invented the process, "*combined steam*."

VI. *Superheating in the cylinder*, by means of a flue or of a furnace, as in Mr. Siemens's steam engine.

296. **Provisional Supposition as to Steam-Gas.**—In that scarcity of exact data respecting the relations between the pressure, temperature, and density of superheated steam which at present prevails, and which has already been mentioned in Article 206, it is necessary to take some *probable assumption* as a *provisional basis* for computations respecting the expenditure of heat, the power and the efficiency of superheated steam engines.

The simplest and most convenient assumption which can be made, and one also which does not involve the risk of any serious error, consists in considering superheated steam as a *perfect gas*, and deducing its density from its chemical composition. Steam considered to be in this state may be called *steam-gas*.

The formula for the product of its pressure in *pounds on the square foot*, p , and the volume of one pound of it in *cubic feet*, v , at any given absolute temperature,

$$\tau = T^{\circ} + 461^{\circ}\cdot 2 \text{ Fahrenheit,}$$

is as follows:—

$$p v = 42140 \cdot \frac{\tau}{\tau_0} = 42140 \cdot \frac{T + 461^{\circ}\cdot 2}{493^{\circ}\cdot 2} = 85\cdot 44 \tau; \dots (1.)$$

and the results of that formula, for every eighteenth degree of Fahrenheit's scale, from $T = 32^{\circ}$ to $T = 572^{\circ}$, are given in the column headed $p v$ in Table IX., at the end of this section.

In the column of the same Table headed H are given the values for the same series of temperatures, of the *total heat of gasification* in foot-pounds required to raise one pound of water from the liquid state at 32° , to the state of perfect gas at a given temperature, under any constant pressure compatible with the perfectly gaseous state at the latter temperature. It is assumed that saturated steam at 32° is perfectly gaseous, so that the total heat of gasification for that temperature, H_0 , is simply the latent heat of evaporation, or

$$H_0 = 842872 \text{ foot-pounds;}$$

and then, according to the principles explained in Article 258, we have for the total heat of gasefication of one pound of steam-gas at any other temperature in foot-pounds—

$$H = H_0 + K_p (T - 32^\circ) = 842872 + 366.7 (T - 32^\circ) \dots (2.)$$

The following are some equivalent expressions for the same quantity:—

$$H = 662016 + 366.7 \tau = 662016 + 4.29 p v \text{ nearly} \dots (2 A.)$$

The column h gives the quantity of heat in foot-pounds required to raise one pound of liquid water from 32° to a given temperature; the increase of the specific heat of liquid water with temperature being taken into account; but in most practical cases it is sufficiently accurate to use the formula

$$h = 772 (T - 32^\circ) \dots \dots \dots (3.)$$

297. **Efficiency of Steam-Gas Expanding without Gain or Loss of Heat.**—In fig. 114, let AB represent v_1 , the volume occupied by one pound of steam-gas when first admitted into the cylinder of an engine at the pressure $p_1 = OA$.

Let BC , being an “adiabatic” curve for steam gas, represent by its co-ordinates the fall of pressure and increase of volume of that fluid as it expands. Let $DC = v_2 = r v_1$ represent the volume, and $OD = p_2$, the pressure, at the end of the expansion, which is assumed not to be carried so far as to cause any appreciable liquefaction of the steam.

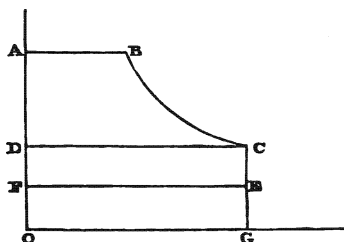

Fig. 114.

Let $OF = p_3$ represent the mean back pressure. The probable value of this in a proposed superheated steam engine may be estimated as follows:—Let the ordinary back pressure in a dry saturated steam engine working at the same speed with the same ratio of expansion be denoted by

$$p' + p'';$$

p' being the pressure of condensation, and p'' the additional pressure. Let τ_1 be the absolute boiling point corresponding to the initial pressure p_1 , and τ'_1 the actual absolute temperature of the steam admitted. Then the steam-gas employed is less dense than

saturated steam of the same pressure in a proportion which may be expressed accurately enough for the present purpose by $\frac{r_1}{r}$; so that according to a principle stated in Article 280, the probable back pressure in the superheated steam engine will be

$$p_3 = p' + \frac{r_1}{r} p'' \dots \dots \dots (1.)$$

In most cases which occur in practice, we may put $p' = 1$ lb. on the square inch, and $p'' = 3$ lbs. on the square inch; so that

$$\left. \begin{aligned} p_3 &= 1 + 3 \frac{r_1}{r} \text{ in pounds on the square inch,} \\ \text{or} \quad 144 + 432 \frac{r_1}{r} &\text{ in pounds on the square foot.} \end{aligned} \right\} \dots (1 A.)$$

The equation of the expansion curve BC may be assumed as analogous to that of the corresponding curve for air, viz:—

$$p \propto v^{-\gamma}; \dots \dots \dots (2.)$$

in which γ and other indices and co-efficients depending on it for steam-gas have the values given them in Article 251, viz:—

$$\left. \begin{aligned} \gamma &= 1.304; \quad \gamma - 1 = 0.304; \\ \frac{1}{\gamma - 1} &= 3.29; \quad \frac{\gamma}{\gamma - 1} = 4.29; \\ \frac{1}{\gamma} &= 0.767; \quad \frac{\gamma - 1}{\gamma} = 0.233. \end{aligned} \right\} \dots \dots \dots (3.)$$

Hence, by an investigation similar to that in Article 279, Method II., is found the following expression for the energy exerted on the piston by one pound of steam-gas:—

$$\begin{aligned} \text{Area A B C E F A} &= U = (p_m - p_3) r v_1 \\ &= p_1 v_1 (4.29 - 3.29 r^{-0.304}) - p_3 r v_1 \dots \dots \dots (4.) \end{aligned}$$

To facilitate the use of this equation, a series of values of the two following ratios and their reciprocals are given in Table X. at the end of this section:—

$$\frac{r p_m}{p_1} = 4.29 - 3.29 r^{-0.304}; \dots \dots \dots (5.)$$

$$\frac{p_m}{p_1} = 4.29 r^{-1} - 3.29 r^{-1.204}; \dots\dots\dots(5 A.)$$

in which Table intermediate values of any ratio can be interpolated as in Tables VII. and VIII., already explained. The following, then, is the set of formulæ to be employed in computing approximately the probable power and efficiency of superheated steam engines, according to the provisional theory here adopted:—

DATA.

Initial pressure, p_1 .

Initial absolute temperature, $\tau'_1 = T'_1 + 461^\circ.2$ Fahrenheit.

Ratio of expansion, r .

Mean back pressure, p_3 , known directly by experiment, or estimated by the formula 1 A.; the absolute boiling point, τ_1 , being found by known formulæ or tables.

Absolute temperature of feed water, $\tau_4 = T_4 + 461^\circ.2$.

Temperature of condensation, T_5 .

Temperature of atmosphere, T_6 .

RESULTS.

$p_1 v_1$ found from T'_1 , by equation 1 of Article 296, or by Table IX.; being the gross energy exerted by the steam on the piston during its admission.

Initial and final volumes of one pound of steam—

$$v_1 = p_1 v_1 \div p_1; v_2 = r v_1 \dots\dots\dots(6.)$$

$\frac{r p_m}{p_1}$, and $\frac{p_m}{p_1}$, found by the equations 5, 5 A, or by Table X.

Energy exerted per pound of steam; found by equation 4, or by the formula—

$$U = \frac{r p_m}{p_1} \cdot p_1 v_1 - r p_3 v_1; \dots\dots\dots(7.)$$

Mean effective pressure—

$$p_m - p_3 = \frac{U}{r v_1} = \frac{p_m}{p_1} \cdot p_1 - p_3 \dots\dots\dots(8.)$$

Heat expended per pound of steam, in foot-pounds—

$$h_j = 842872 + 366.7 (T'_1 - 32^\circ) - 772 (T_4 - 32^\circ), \dots(9.)$$

or
$$h_j = H_1 - h_4; \dots\dots\dots(9 A.)$$

H_1 and h_4 being found by means of Table IX.

Pressure equivalent to heat expended—

$$p_a = \frac{h}{r v_1} \dots \dots \dots (10.)$$

Efficiency of steam—

$$\frac{p_m - p_3}{p_a} = \frac{U}{h} \dots \dots \dots (11.)$$

Net feed water per cubic foot swept through by piston—

$$\frac{1}{r v_1} \dots \dots \dots (12.)$$

Heat rejected per pound of steam—

$$h - U \dots \dots \dots (13.)$$

Heat rejected per cubic foot swept through by piston—

$$\frac{h - U}{r v_1}; \dots \dots \dots (14.)$$

Net condensation water—

$$= \frac{\text{heat rejected}}{772 (T_5 - T_6)} \dots \dots \dots (15.)$$

Available heat expended per indicated horse-power per hour—

$$1980000 \frac{h}{U} \dots \dots \dots (16.)$$

In the following example (which is ideal), the engines are supposed to be the same with those already employed as Example I. in Article 289; and the principal question to be solved by the calculation is, what would be the probable increase of efficiency and saving of fuel if the steam, being admitted at the same mean pressure of 34 lbs. on the square inch, and cut off at the same mean effective fraction of its final volume, 0·2, were superheated so as to be admitted at the temperature $T_1 = 428^\circ$, instead of its present mean temperature of admission, which is about $257\frac{1}{4}^\circ$.

DATA.

$$p_1 = 34 \times 144 = 4896;$$

$$r_1 = 428 + 461\cdot2 = 889\cdot2.$$

$$r = 5.$$

$$p_3 = 144 + 432 \cdot \frac{719}{889} = 493 \text{ lbs. on the square foot,}$$

(or 3.43 lbs. on the square inch).

$$T_4 = 104.$$

RESULTS.

$p_1 v_1$, by Table IX., 75976 foot-pounds

$$v_1 = \frac{75976}{4896} = 15.52 \text{ cubic feet.}$$

$$v_2 = r v_1 = 5 \times 15.52 = 77.6 \text{ cubic feet.}$$

By Table X.— $\frac{r p_m}{p_1} = 2.28$; $\frac{p_m}{p_1} = .456$.

Energy per pound of steam—

$$\begin{aligned} U &= 2.28 \times 75976 - 493 \times 77.6 \\ &= 173225 - 38257 = 134968 \text{ foot-pounds.} \end{aligned}$$

Mean effective pressure—

$$\begin{aligned} p_m - p_3 &= .456 \times 4896 - 493 = 1740 \text{ lbs. on the square foot,} \\ &= 12.08 \text{ lbs. on the square inch.} \end{aligned}$$

Heat expended per pound of steam—

$$h = 988085 - 55612 = 932473.$$

Pressure equivalent to heat expended—

$$\begin{aligned} p_h &= \frac{932473}{77.6} = 12016 \text{ lbs. on the square foot.} \\ &= 83.44 \text{ lbs. on the square inch.} \end{aligned}$$

Efficiency of steam—

$$\frac{134968}{932473} = \frac{1740}{12016} = \frac{12.08}{83.44} = 0.145;$$

being superior to the efficiency with dry saturated steam, as computed in Article 289, Example I., in the ratio

$$\frac{.145}{.128} = 1.18 : 1.$$

The available heat expended per indicated horse-power per hour would be

$$\frac{1980000}{0.145} = 13655000 \text{ foot-pounds;}$$

and supposing, as in some previous examples, the available heat of combustion of one pound of the coal employed to be

$$5400000 \text{ foot-pounds,}$$

the consumption of coal per indicated horse-power per hour would be

$$\frac{13655000}{5400000} = 2.53 \text{ lbs.};$$

which, being subtracted from the actual consumption, 2.97, shows a saving of 0.44 lb., or about 15 per cent.

This is less than the saving which has usually been found by experiment to result from superheating; the reason probably being, that in the preceding calculation no account is taken of the increased *efficiency of the furnace*, owing to the superheating apparatus taking up heat which would otherwise have been wasted.

To estimate the probable effect of this cause in giving increased economy, let us make the supposition (which appears to have been nearly realized in some cases), that the *whole* of the superheating is effected by heat which would otherwise have been wasted.

	Foot-lbs.
Then the heat required to produce 1 lb. of saturated steam at 34 lbs. on the square inch, from water at 104° being.....	840,000
and the heat required to produce 1 lb. of superheated steam at 428° Fahrenheit, from water at 104° being, as computed before,	932,473
the difference,.....	92,473

is to be considered, according to the supposition made, as heat saved by the superheating apparatus; so that the efficiency of the furnace is increased in the ratio

$$\frac{932473}{840000} = 1.11 \text{ nearly;}$$

and the available heat of combustion of the coal, instead of 5,400,000, becomes,

$$5,400,000 \times 1.11 = 6,000,000 \text{ foot-lbs.}$$

giving as the probable consumption of coal per indicated horse-power per hour,

$$\frac{13655000}{6000000} = 2.28 \text{ lbs.,}$$

which, being subtracted from.....2.97

shows a saving of.....0.69 lb.

or about 23 per cent. This agrees very nearly with the general results of practice.

298. *Efficiency of Steam-Gas Expanding at Constant Temperature.*—If the temperature of steam-gas be maintained constant during its expansion, by means of a flue round the cylinder, or otherwise, its action is represented approximately by making the curve B C, fig. 114, a common hyperbola, so that

$$p \propto \frac{1}{v}$$

In this case, the principal formulæ are the following:—

Energy exerted by 1 lb. of steam

$$= \text{area A B C E F A}$$

$$= U = (p_m - p_s) r v_1 = p_1 v_1 (1 + \text{hyp log } r) - p_s r v_1 \dots (1.)$$

$$\frac{r p_m}{p_1} = 1 + \text{hyp log } r; \dots \dots \dots (2.)$$

$$\frac{p_m}{p_1} = \frac{1 + \text{hyp log } r}{r} \dots \dots \dots (2 A.)$$

A series of values of these ratios, and of their reciprocals, is given in Table XI. at the end of this section.

The *heat expended per pound of steam* consists of the *total heat of gasefication, from T₄*, the temperature of the feed water, to T₁, the temperature of the steam-gas, as already computed in Articles 296 and 297, and given by the aid of Table IX., and of the *latent heat of expansion* which the steam receives to maintain its temperature constant in the cylinder, and whose value is

$$p_1 v_1 \text{ hyp log } r = 85.44 r'_1 \text{ hyp log } r = p_1 v_1 \cdot \left(\frac{r p_m}{p_1} - 1 \right); \dots (3.)$$

hence, denoting the whole expenditure of heat per lb. of steam by \mathfrak{h} ,

$$\begin{aligned}\mathfrak{h} &= H_1 - h_4 + p_1 v_1 \left(\frac{r p_m}{p_1} - 1 \right) \\ &= 842872 + 366.7 (T_1 - 32^\circ) - 772 (T_4 - 32^\circ) \\ &\quad + 85.44 \text{ hyp log } r (T_1 + 461^\circ.2) \\ &= 662016 + p_1 v_1 \left(3.29 + \frac{r p_m}{p_1} \right) - 772 (T_4 - 32^\circ) \dots (4.)\end{aligned}$$

To illustrate this mode of employing steam-gas, let the data taken be the same as in the example of Article 297; that is, let

$$\begin{aligned}p_1 &= 34 \times 144 = 4896; \\ r_1 &= 889.2 = 428^\circ + 461.2; \\ r &= 5; \\ p_3 &= 493; \\ T_4 &= 104^\circ.\end{aligned}$$

RESULTS.

$$p_1 v_1 = 75976; \quad v_1 = 15.52; \quad r v_1 = 77.6; \quad \text{as before.}$$

$$\text{By Table XI.,} \quad \frac{r p_m}{p_1} = 2.61; \quad \frac{p_m}{p_1} = .522.$$

Energy per lb. of steam—

$$\begin{aligned}U &= 2.61 \times 75976 - 493 \times 77.6 \\ &= 198297 - 38257 = 160040 \text{ foot-lbs.}\end{aligned}$$

Mean effective pressure—

$$\begin{aligned}p_m - p_3 &= .522 \times 4896 - 493 = 2063 \text{ lbs. on the square foot} \\ &= 14.38 \text{ lbs. on the square inch.}\end{aligned}$$

Heat expended per lb. of steam—

$$\begin{aligned}\mathfrak{h} &= 988085 - 55612 + 75976 \times 1.61 \\ &= 932473 + 122321 = 1054794 \text{ foot-lbs.}\end{aligned}$$

Pressure equivalent to that heat—

$$\begin{aligned}p_\Delta &= \frac{1054794}{77.6} = 13593 \text{ lbs. on the square foot} \\ &= 94.4 \text{ lbs. on the square inch.}\end{aligned}$$

Efficiency of steam—

$$\frac{160040}{1054794} = \frac{2063}{13593} = \frac{14.33}{94.4} = 0.152,$$

being superior to the efficiency with dry saturated steam in the ratio

$$\frac{0.152}{0.123} = 1.236 : 1 \text{ nearly.}$$

The available heat expended, per indicated horse-power per hour, would be in this case

$$\frac{1980000}{0.152} = 13,000,000 \text{ foot-lbs.}$$

If the efficiency of the furnace, as in the second mode of treating the example in Article 297, be supposed to be such that the available heat of combustion of 1 lb. of coal is

$$6,000,000 \text{ foot-lbs.,}$$

the probable consumption of coal in the engine now under consideration, per indicated horse-power per hour, is found to be

$$\frac{13000000}{6000000} = 2.17 \text{ lbs.}$$

which being subtracted from the
 actual consumption with dry } 2.97
 saturated steam,..... }

shows a saving of..... 0.80 lb.
 or 27 per cent.

299. Efficiency of Steam-Gas with Regenerator—Siemens's Engine.

—The “regenerative steam engine” of Mr. C. W. Siemens, is one which so far agrees with the description in the last Article, that superheated steam works expansively in it at a temperature maintained nearly constant by placing the cylinder over a furnace; but the steam on its way to and from the space below the plunger of that cylinder, traverses a “regenerator” nearly resembling that of Stirling’s air engine (see Article 275), the effect of which is, that the whole, or nearly the whole, of the heat employed to raise the temperature of the steam above the boiling point corresponding to its pressure, is obtained at each stroke from the regenerator, in which that heat has previously been stored by steam leaving the hot end of the cylinder.

The whole of the formulæ of the Article 298 are made applicable to this case, by simply taking for the value of H_1 , the total heat of evaporation of 1 lb. of steam at the boiling point τ_1 , corresponding to its pressure, as given by Table VI. at the end of the volume, instead of the total heat of gasefication at the working temperature τ'_1 . Suppose, for example, that the data are the same as in the last Article. Then the total heat of evaporation of steam at 34 lbs. on the square inch, the feed water being at 104° , as computed for Table VI., is..... $H_1 - h_4 = 840000$ foot-lbs.,

the latent heat of expansion, as in Article 298,.. } $p_1 v_1 \left(\frac{r p_m}{p_1} - 1 \right) = 122321$

and the heat expended per lb. of steam \bar{h} = 962321 foot-lbs.

Also, the energy exerted by 1 lb. of steam, being, as in Article 298,

$$U = 160040 \text{ foot-lbs.},$$

the efficiency of the steam is

$$U \div \bar{h} = \frac{160040}{962321} = 0.166;$$

consequently, the available heat expended per indicated horse-power per hour is

$$\frac{1980000}{0.166} = 11,930,000 \text{ foot-lbs. nearly.}$$

Taking the same estimate of the available heat of combustion of 1 lb. of coal, as in Article 298, this would give for the consumption of coal per indicated horse-power per hour

$$\frac{11,930,000}{6,000,000} = 1.99 \text{ lb.}$$

The efficiency of this engine is capable of being greatly increased by working at a high temperature; for while the energy exerted by the steam increases nearly as the absolute temperature, it is only the latent heat of expansion which increases in the same proportion: the total heat of evaporation remaining constant if the pressure is constant. Mr. Siemens states, that in some of his experiments with this engine, the consumption of fuel was only 1.5 lb. per indicated horse-power per hour.

The heating apparatus described at the end of Article 275, might probably be applied to this engine with advantage.

IX.

TABLE OF ELASTICITY AND TOTAL HEAT OF ONE POUND OF STEAM-GAS.

T	$p v$	H	h
32°	42140	842872	0
50	43678	849473	13896
68	45216	856073	27792
86	46754	862674	41702
104	48292	869274	55612
122	49830	875875	69522
140	51368	882476	83459
158	52906	889076	97411
176	54444	895677	111363
194	55982	902277	125357
212	57520	908878	139363
230	59058	915479	
248	60596	922079	
266	62134	928680	
284	63672	935280	
302	65210	941881	
320	66748	948482	
338	68286	955082	
356	69824	961683	
374	71362	968283	
392	72900	974884	
410	74438	981485	
428	75976	988085	
446	77514	994686	
464	79052	1001286	
482	80590	1007887	
500	82128	1014488	
518	83666	1021088	
536	85204	1027689	
554	86742	1034289	
572	88280	1040890	

EXPLANATION.

T, temperature on Fahrenheit's scale.

$p v$, product of the pressure in pounds on the square foot, and volume in cubic feet, of one pound of steam in the perfectly gaseous condition, or "steam-gas."

H, total heat, in foot-pounds of energy, required to convert one pound of water at 32° into steam-gas at T°, under any constant pressure.

h , heat, in foot-pounds of energy, required to raise the temperature of one pound of water from 32° to T°.

X.

TABLE OF APPROXIMATE RATIOS FOR STEAM-GAS WORKING EXPANSIVELY.

r	$\frac{1}{r}$	$\frac{r p_m}{p_1}$	$\frac{p_1}{r p_m}$	$\frac{p_1}{p_m}$	$\frac{p_m}{p_1}$
20	·05	2·97	·337	6·74	·148
$13\frac{1}{3}$	·075	2·80	·357	4·76	·210
10	·1	2·66	·376	3·76	·266
8	·125	2·56	·391	3·13	·320
$6\frac{2}{3}$	·15	2·45	·408	2·73	·367
5	·2	2·28	·439	2·20	·456
4	·25	2·13	·469	1·88	·532
$3\frac{1}{2}$	·3	2·01	·498	1·66	·603
$2\frac{2}{7}$	·35	1·90	·526	1·50	·665
$2\frac{1}{4}$	·4	1·80	·556	1·39	·720
$2\frac{1}{3}$	·45	1·71	·585	1·30	·770
2	·5	1·63	·613	1·23	·815
$1\frac{2}{11}$	·55	1·55	·645	1·17	·852
$1\frac{2}{5}$	·6	1·47	·680	1·13	·882
$1\frac{1}{13}$	·65	1·40	·714	1·10	·910
$1\frac{2}{7}$	·7	1·34	·746	1·07	·938
$1\frac{1}{3}$	·75	1·28	·781	1·04	·960
$1\frac{1}{4}$	·8	1·22	·820	1·025	·976
$1\frac{2}{17}$	·85	1·16	·862	1·014	·986
$1\frac{1}{3}$	·9	1·10	·909	1·01	·990

EXPLANATION.

r , ratio of expansion.

$\frac{1}{r}$, real cut-off.

p_1 , absolute pressure of admission.

p_m , mean absolute pressure.

$\frac{r p_m}{p_1}$, ratio of whole gross work of steam on piston to gross work during admission.

$\frac{p_1}{r p_m}$, ratio of gross work during admission to whole gross work.

XI.

TABLE OF APPROXIMATE RATIOS FOR PERFECT GASES WORKING EXPANSIVELY AT CONSTANT TEMPERATURE.

r	$\frac{1}{r}$	$\frac{r p_m}{p_1}$	$\frac{p_1}{r p_m}$	$\frac{p_1}{p_m}$	$\frac{p_m}{p_1}$
20	·05	4·00	·250	5·00	·200
13½	·075	3·59	·279	3·72	·269
10	·1	3·30	·303	3·03	·330
8	·125	3·08	·325	2·60	·385
6½	·15	2·90	·345	2·30	·435
5	·2	2·61	·383	1·92	·522
4	·25	2·39	·419	1·68	·596
3½	·3	2·20	·454	1·51	·661
2¾	·35	2·05	·488	1·39	·717
2½	·4	1·91	·523	1·31	·765
2⅔	·45	1·80	·556	1·24	·809
2	·5	1·69	·591	1·18	·846
1⅞	·55	1·60	·626	1·14	·878
1¾	·6	1·51	·662	1·10	·906
1⅘	·65	1·43	·699	1·07	·929
1⅓	·7	1·36	·737	1·05	·950
1¼	·75	1·29	·777	1·04	·965
1½	·8	1·22	·818	1·02	·978
1⅙	·85	1·16	·860	1·01	·989
1⅓	·9	1·11	·905	1·01	·995

EXPLANATION.

r , ratio of expansion.

$\frac{1}{r}$, real cut-off.

p_1 , absolute pressure of admission.

p_m , mean absolute pressure.

$\frac{r p_m}{p_1}$, ratio of whole gross work of gas on piston to gross work during admission.

$\frac{p_1}{r p_m}$, ratio of gross work during admission to whole gross work.

SECTION 7.—*Of Binary Vapour Engines.*

300. **General Description of the Binary Vapour Engine.**—This engine (sometimes called the “combined vapour engine”), the invention of M. Prospère-Vincent du Trembley, is driven by the combined action of two different fluids, a less and a more volatile, in two separate cylinders. The less volatile fluid is evaporated in a boiler, and drives the piston of its cylinder, in the usual way. On being discharged, it is passed vertically downwards through a set of small tubes, contained within a cylindrical vessel; this apparatus is at once the *condenser* for the less volatile fluid, and the *evaporator* for the more volatile fluid; for the less volatile fluid, passing downwards through the tubes, is liquefied, and gives out its heat to the more volatile fluid, which ascends in the space surrounding the tubes, and reaches the top of the vessel in the state of vapour. This vapour drives the piston of a second cylinder, during the return stroke of which it is expelled into a second surface condenser, consisting also of a number of small vertical tubes; the vapour passes downwards through these tubes, which are surrounded by a copious stream of cold water; this abstracts heat from the vapour, and causes it to be condensed, and the liquid thus produced is pumped back into the evaporating vessel to perform its work over again.

The less volatile fluid is always water; for the more volatile, æther is usually employed: chloroform has also been tried; and bisulphuret of carbon has been recommended on account of its abundance and cheapness. All these fluids, when breathed in the vaporous state, are stupefying, and in large quantities poisonous; æther is highly inflammable; æther and chloroform are very costly; and sulphuret of carbon, even when it escapes in quantities far too small to be stupefying, causes a most disgusting and insupportable stench. It is, therefore, necessary that extraordinary care should be bestowed upon making the joints of that part of the apparatus which contains the more volatile fluid perfectly tight, so that no perceptible portion of it shall escape. This appears to have been accomplished with great success by M. du Trembley, in his steam and æther engines, by which several ships are propelled.

Full and minute details of the construction and mode of working of these engines are given in M. du Trembley's work, entitled, *Manuel du Conducteur des Machines à Vapeurs combinées, ou Machines Binaires* (Lyons, 1850–51); and accounts of their performance are contained in a report by Mr. George Rennie, published in 1852; in a lithographed report by M. E. Gouin, on the experimental trip of the ship “Brésil,” in 1855; and in a paper by Mr.

James W. Jamieson, read to the Institution of Civil Engineers in February, 1859.

301. **Theory of the Steam-and-Æther Engine.**—In fig. 115, let A B C E F A represent the diagram of the steam cylinder, and K L M P Q K that of the æther cylinder.

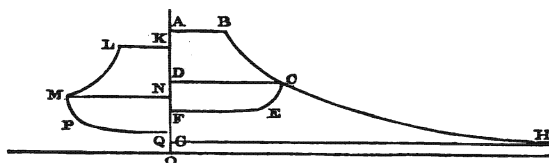

Fig. 115.

Let $p_1 = \overline{O A}$ be the absolute pressure of the steam at its admission;

$v_1 = \overline{A B}$, the volume of one lb. of it when admitted;

$r v_1 = \overline{D C}$, the volume to which it expands;

Let its back pressure be indicated by the curve C E F;

Let H_1 denote the available heat expended, in foot-lbs. per lb. of steam;

$U = \text{area } A B C E F A$, the energy exerted on the piston by one lb. of steam.

Then the *heat rejected* by each lb. of steam, and given out through the tubes of the steam-condensing and æther-evaporating apparatus to the æther, is given by the equation

$$H_2 = H_1 - U ; \dots\dots\dots(1.)$$

and several examples of the mode of computing this quantity of heat have been given in the preceding sections.

To find what *volume* will be filled with æther vapour by means of this heat, in the first place must be computed the expenditure of heat *per cubic foot of æther vapour*, produced at the pressure under which the æther is evaporated, which is supposed to be given and represented by $p' = \overline{O K}$, and is necessarily a pressure corresponding to a boiling point lower than the temperature at which the steam is condensed. That expenditure of heat is given by the formula

$$L' + J c' D' (T' - T''), \dots\dots\dots(2.)$$

where

$L' = r \frac{d p'}{d \tau}$ is the latent heat of evaporation of one cubic foot of æther vapour under the given pressure, calculated by a formula of the kind given in Article 255, or by the aid of Table V.;

$J \epsilon = 399.1$ foot-lbs. per degree of Fahrenheit, is the specific heat of liquid æther;

D' is the weight of one cubic foot of æther vapour, found by the formulæ of Article 256, or by the aid of Table V.;

T' is the temperature at which the æther is evaporated, and T''' that at which it is condensed, and returned to the evaporating apparatus.

The value of the expression 2 having been computed, the initial volume, represented by \overline{KL} in the figure, of the æther evaporated per lb. of steam condensed, is found by means of the equation

$$u' = \overline{KL} = \frac{H_2}{L' + J \epsilon D' (T' - T''')} \dots \dots \dots (3.)$$

Let $p'' = \overline{ON}$ denote the intended final pressure of the æther vapour, at the end of its expansion, and p''' its mean back pressure, which appears to be about 5 lbs. on the square inch. Then from the data, p' , p'' , p''' , T''' , by means of the formulæ of Articles 281 and 284, substituting only the constants which apply to æther for those which apply to steam, and using Table V. instead of Table IV., may be computed—

The ratio of expansion r' , and thence the final volume $\overline{MN} = r' u'$ of the æther evaporated per lb. of steam;

The energy exerted by that æther, represented by the area $KLMQK = U'$.

The ratio

$$\frac{\overline{MN}}{DC} = \frac{r' u'}{r v_1} \dots \dots \dots (4.)$$

is that of the volume of the æther cylinder to the volume of the steam cylinder. In practice, those cylinders are either of equal size, or the æther cylinder is somewhat the larger.

The heat per lb. of steam to be abstracted by the cold water which circulates in the æther condenser, is given by the expression

$$H_1 - U - U' \dots \dots \dots (5.)$$

The mean effective pressures in the steam cylinder and æther cylinder respectively, are

$$\frac{U}{r v_1} \text{ and } \frac{U'}{r' u'} \dots \dots \dots (6.)$$

It is certain that the same amount of additional energy, which is obtained by the addition of the æther engine to the steam engine, might also be obtained by continuing the expansion of the steam

sufficiently far, as represented by the line C H G, provided a sufficiently low back pressure could be insured; but this might require in some cases a cylinder so large, as to be more costly than the binary engine.

The addition of an æther engine appears to be an excellent means of improving the efficiency and economy of an existing steam engine.

302. **Example of Results of Experiments.**—The following quantities are *means*, computed from a long series of experimental results given in M. Gouin's report already mentioned, on the performance of the steam and other engines of the "Brésil:"—

	PRESSURES IN LBS. ON THE SQUARE INCH.		
	In boiler or evaporator.	Back pressure.	Mean effective.
Steam,.....	43'2	7'6	11'6
Æther,.....	31'2	5'3	7'1

Total mean effective pressure reduced to the area of *one piston*, the areas and strokes of the steam and æther pistons having been in this case the same,..... 18'7

It thus appears, that the proportions of the indicated power of the engine obtained in the steam and æther cylinders respectively, were

$$\text{In the steam cylinder, } \frac{11.6}{18.7} = .62;$$

$$\text{In the æther cylinder, } \frac{7.1}{18.7} = .38.$$

The gain of power, however, by the addition of the æther engine, is not quite so great as this calculation shows; because, had the steam cylinder been used alone, the back pressure would have been in all probability about 3 lbs. on the square inch less; that is, about 4.6 instead of 7.6; so that the mean effective pressure in the steam cylinder would have been 14.6 instead of 11.6; and the proportion borne by the power of the steam engine alone to that of the binary engine would have been

$$\frac{14.6}{18.7} = .77,$$

leaving

$$1.00 - .77 = .23$$

of the whole power of the binary engine, as the real gain due to the æther engine.

The consumption of fuel, according to M. Gouin's report, was either

2·8 } lbs. of coal per indicated horse-power per hour,
or 2·44 }

according as certain experiments made under peculiarly adverse circumstances were included or excluded.

The binary engine is not more economical than steam engines designed with due regard to economy of fuel; but by the addition of an æther engine, a wasteful steam engine may be converted into an economical binary engine.

CHAPTER IV.

OF FURNACES AND BOILERS.

SECTION I.—*Of Boilers and Furnaces in general.*

303. **General Arrangements of Furnace and Boiler.**—The usual relative arrangements or positions of the furnace and boiler of a steam engine may be divided into three principal classes; as follows:—

I. In the **External Furnace Boiler**, the furnace or fire-chamber is wholly outside of, and partly in contact with, the water vessel or boiler; so that the boiler forms *part* of the boundary of the furnace (generally the top). The other boundaries of the furnace are usually built of fire-brick. As to the thickness required to prevent loss by radiation, see Article 228. Examples of this are—the old hay-stack boiler and wagon boiler, the plain cylindrical boiler, without internal flues, and some boilers, such as Gurney's, Perkins's, and Craddock's, in which the water and steam are contained in tubes surrounded by the flame.

II. In the **Internal-Furnace Boiler**, the fire-chamber is enclosed within the boiler. Examples of this are—the boilers now most common in land engines, with one or more furnaces contained in horizontal cylindrical internal flues; most marine boilers; and all locomotive boilers.

III. The **Detached Furnace or Oven** is a fire-chamber built of brick, in which the combustion is completed before the hot gas comes in contact with any part of the boiler. This has been already referred to in Article 230, page 283.

304. **The Principal Parts and Appendages of a Furnace** are—

I. The *furnace proper*, or *fire-box*, being the space where the solid constituents of the fuel, and the whole or part of its gaseous constituents, are burned.

II. The *grate*, being that part of the bottom of the furnace proper which is composed of alternate bars and spaces, to support the fuel and admit air.

III. The *hearth* is a floor of fire-brick, on which, instead of on a grate, the fuel is burned in some furnaces.

IV. The *dead plate*, or *dumb plate*, being that part of the bottom of the furnace proper which consists of an iron plate, without bars and spaces.

V. The *mouth-piece*, being the passage through which fuel is introduced, and sometimes also air. The bottom of the mouth-piece is a dead plate. In many furnaces there is a mere doorway, and no mouth-piece.

VI. The *fire-door*, which closes the mouth-piece or doorway, and which may or may not have openings and valves in it to admit air. Sometimes the duty of a fire door is performed by a heap of dross closing up the mouth-piece.

VII. The *furnace-front*, above and on either side of the fire door.

VIII. The *ash-pit*, being the space below the grate into which the ashes fall, and through which, in most cases, the greater part of the supply of air is admitted.

IX. The *ash-pit door*, used in some furnaces to regulate the admission of air through the ash-pit.

X. The *bridge*, being a low vertical partition at one end of the furnace (usually the back) over which the flame passes on its way to the flues or chimney. This is what is meant when "the bridge" is spoken of without qualification; but the word *bridge* is also applied to any low partition having a passage for flame or hot gas above it. Bridges are usually built of fire-brick; but they are also sometimes made of plate iron, and hollow, so as to contain water within, and form part of the water space of the boiler—they are then called "*water bridges*." The top of a water bridge ought to slope or curve upwards towards the ends, to admit of the rapid escape of the bubbles of steam which form on its internal surface. Sometimes a water bridge projects downwards from a part of the boiler above the furnace, leaving a passage below for flame—it is then called a "*hanging bridge*." A water bridge with passages for flame, both above and below, is called a "*mid-feather*."

XI. The *flame chamber*, being the space immediately behind the bridge in which the combustion of the inflammable gases that pass over the bridge is or ought to be completed. It has often a floor of fire-brick, called the *flame bed*; and is sometimes lined with fire-brick to prevent the cooling and extinction of the flame, and sometimes, for the same purpose, filled with fire clay tiles, made of a horse-shoe form in section, to admit of the circulation of the gases.

XII. *Air passages*, of various constructions and in various situations, and with or without valves, to admit air for the combustion of the fuel, whether forced in by atmospheric pressure or by a blowing machine.

XIII. *Flues*, being passages traversed by the hot gas on its way from the fire to the chimney. These are sometimes *external*, being in contact with the outside of the boiler, and bounded externally by brickwork; and sometimes *internal*, being contained within,

and forming part of, the boiler. Internal flues of small diameter are called *tubes*.

XIV. *Baffles* or *diffusers*, being partitions so placed as to improve the convection of heat, by promoting the completeness of the circulation of the particles of hot gas over the heating surface of the boiler. The various *bridges* already mentioned fall under this head, and also the spiral blades for boiler tubes recently introduced by Messrs. Duncan & Gwynne.

XV. The *chimney* (see Article 233), at the foot of which is sometimes a chamber called the *smoke box*, or *uptake*, in which the various flues terminate.

XVI. *Blowing apparatus*, used in order to produce a draught, whether by forcing air into the furnace by means of a fan, or by driving the gases out of the chimney by means of a blast pipe. See Article 233.

XVII. *Dampers*, being valves placed in the chimney, flues, tubes, or air passages, to regulate the draught and rate of combustion.

No one furnace possesses *all* the parts and appendages above enumerated; for some of them are substitutes for others, and some are only employed in furnaces of particular kinds.

305. The **Principal Parts and Appendages of a Boiler** are—

I. The *shell*, or external boundary of the boiler, for which the usual material is iron, although sheet copper is sometimes employed. The figures usually employed for the shells of boilers are, the spherical, the cylindrical, and the plane, and combinations of those three figures. The most common figure at the present day is that of a horizontal cylinder, with flat or hemispherical ends. In some peculiar boilers, the shell is a vertical cylinder, or a cluster of vertical tubes connected by means of horizontal tubes (as in Mr. Craddock's boiler); or a set of square tubes or cells (as in Mr. J. M. Rowan's boiler); or a single spiral tube (as in Mr. Perkins's boiler). Tubes which thus contain water internally are called *water tubes*, to distinguish them from tubes for transmitting furnace gas. In most locomotive boilers, part of the shell is a rectangular box, containing within it another rectangular box, which latter is the fire-box. The shells of ordinary marine boilers are of irregular shapes, adapted to the space in the ship which they are to occupy, and approximating more or less to rectangular figures, rounded at the corners and arched at the top.

II. The *steam chest*, or *dome*, being a part of the shell which usually rises above the level of the rest of the boiler, so as to provide a space in which the steam, before being conducted to the engine, may deposit any particles of spray that it may have carried up from the water. It is usually cylindrical, with a hemispherical or segmental top; but its form is often varied, especially in marine boilers. It

is advantageous that the steam chest should be traversed or surrounded by a flue, in order to dry or slightly superheat the steam, as explained in Article 295, page 429.

III. The *furnace* or *fire-box* (in boilers with internal furnaces) is a chamber contained within the boiler, in such a position as to be completely covered with water. In ordinary cylindrical land boilers it is usually cylindrical, being at one end of a horizontal cylindrical flue: in locomotive boilers it is sometimes a vertical cylinder, but more frequently a rectangular box. In marine boilers it is usually of a figure approaching to rectangular, with rounded corners.

Many of the parts mentioned in the last Article as belonging to furnaces, become, when the furnace is internal, parts of the boiler also; for example, the ash-pit, in the cylindrical internal furnace of a horizontal cylindrical boiler, is simply the space below the grate within the cylindrical flue which contains the furnace. Water bridges have already been described.

The principal bridge at the back of an internal furnace is usually of fire-brick. Sometimes, in order to prevent the cooling of the flame by contact with the surface of a water space before the combustion is complete, the furnace is lined internally with a fire-brick arch; and sometimes also an internal flame chamber (Article 304, Division XI.) adjoining the furnace is lined in the same manner.

One boiler may contain one, two, or more internal furnaces.

IV. *Internal flues*, and *internal tubes*, being small internal flues, have already been mentioned under head XIII. of Article 304.

V. A *tube-plate* is a plate which forms sometimes part of the shell of the boiler, and sometimes one side of an internal fire-box, flame chamber, or flue, and which is perforated with holes, into which the ends of a set of tubes are fixed. Each set of tubes requires a pair of tube-plates, one for each end of the tubes.

VI. The *man-hole* is a circular or oval orifice in any convenient position on the top of the boiler, large enough to admit a man to the interior of the boiler to cleanse or repair it. The entrance to the man-hole usually consists of a short cylinder having a flange surrounding its upper end, to which the cover is bolted, when the cover opens outwards. The bolts must be capable of safely bearing the pressure of the steam against the cover. Sometimes the cover opens inwards, and then it is kept shut by the pressure of the steam; but to prevent its being dislodged from its seat, it is held by bolts and nuts to cross bars outside the man-hole. The cover should fit its seat very accurately.

VII. *Mud-holes* are orifices at or near the lowest part of a boiler, which are opened occasionally for the discharge of sediment.

VIII. The *feed apparatus*, by which water is introduced into the

boiler to supply the place of that which has been discharged in the state of steam or otherwise, is usually supplied by a pump worked by the engine. In marine and locomotive engines, the rate at which feed water is supplied is regulated by a cock under the control of the engineer; the surplus water which comes from the feed pump being discharged through a valve loaded with a pressure greater than that in the boiler; but in stationary boilers, there is often a self-acting apparatus to regulate the feed, controlled by a float which rises and falls with the level of the water in the boiler. The proper dimensions of feed pumps will be considered farther on.

In cases in which a *float* within a boiler is used, it ought to rise and fall within a casing, communicating with the rest of the boiler through small holes near the top and bottom only. The water within the casing will preserve the same mean level with that throughout the rest of the boiler, but will be free from the agitation which is produced in all other parts of the boiler by the disengagement of steam.

IX. The *blow-off apparatus* consists, in fresh water boilers, simply of a large cock at the bottom of the boiler, which is opened occasionally to cleanse the boiler by emptying it completely of sediment and muddy water. In many marine boilers, fed with salt water, a similar cock is opened at regular intervals to discharge brine, and so prevent salt from collecting in the boiler. Another blow-off cock is sometimes so placed as to discharge occasionally the *scum*, consisting of crystals of salt, which collects on the surface of the water: this is called the "*surface blow*."

As a substitute for the common blow-off apparatus, Messrs. Maudslay introduced *brine pumps*, which draw off a fixed quantity of brine from the bottom of the boiler at each stroke of the engine.

The hot brine, whether blown off or pumped off, is, or ought to be, passed through a set of tubes, surrounded by a casing through which the feed water passes on its way to the boiler; the currents of the brine and of the feed water flowing in opposite directions. By means of this apparatus, called the *refrigerator*, the greater part of the heat which would otherwise be wasted with the brine is saved by being transferred to the feed water.

X. The *sediment collector*, used in some marine boilers, is a funnel shaped like an inverted cone, and placed within the boiler so that its mouth is somewhat above the water level. It communicates with the rest of the boiler through triangular slits near its upper edge. In the boiler generally, there is a continual boiling up of steam, which keeps crystals of salt and other solid particles for a time near the surface of the water. Within the cone there is comparatively still water, so that the solid impurities collect

there, and sink down to the bottom, or apex of the cone, whence they are from time to time blown off, being first stirred up if necessary.

XI. The *steam pipe* conveys the steam from the boiler to the engine. As to its dimensions and resistance, see Article 290. Besides the throttle valve or regulator, by which the supply of steam to the engine is controlled, the steam pipe of every boiler should be provided with a perfectly steam tight *stop valve* (being usually a conical valve worked by means of a screw) to be shut when the boiler is not in use.

XII. *Safety valves*, for letting the steam escape from the boiler when its pressure tends to rise too high, have been partially mentioned in Article 113, and will be further considered in a subsequent Article. Every boiler should have two, one being placed beyond the control of the engineman.

XIII. The *vacuum valve* is a safety valve opening inwards, to admit air into the boiler, and so to prevent it from collapsing, in the event of the steam within it falling below the atmospheric pressure.

XIV. The *fusible plug* is a piece of metal or alloy stopping an aperture in some part of the boiler which is directly exposed to the fire, and of such a composition as to melt at a temperature lower than that at which the pressure of the steam would become dangerous. As to the melting points of various metals and alloys, see Article 205, page 235. Little confidence is now placed in this contrivance; for it has been known to fail completely in various cases of boiler explosions.

XV. The *pressure gauge* shows to the engineer the excess of the pressure within the boiler above that of the atmosphere. As to various pressure gauges, see Article 107 A. That which is now almost universally preferred for steam boilers is Bourdon's (see pages 111, 112).

XVI. The *water gauge* shows to the engineer the level of the water in the boiler; and especially, whether it stands high enough to cover all those parts of the boiler which are directly exposed to the fire. The old form of water gauge consists of three cocks at different levels; one at the proper level of the water, another a few inches above that level, and a third a few inches below. By opening these the engineer can ascertain the level of the water approximately. The new form which is most frequently used, consists of a strong vertical glass tube, communicating with the boiler above and below the proper water level through cocks, which can be shut if the tube is accidentally broken. The level of the water is visible in this tube. Every boiler ought to be provided with *both* forms of water gauge, the cocks and the glass tube;

so that if the tube should be choked or broken, the cocks may be employed. There are other forms of water gauge, in which a float acts upon an index; but they are less used than the two forms before mentioned.

In the æther evaporator of M. du Trembley's binary engine, where a glass tube would be dangerous, an iron float on the surface of the æther rises and falls in a vertical brass tube, and its position is indicated by a magnetic needle outside.

XVII. A *steam whistle* may be used, as in locomotives, merely to make signals; but it may also be acted upon by a pressure gauge, or by a float, so as to give warning of the pressure rising too high, or the water level falling too low.

XVIII. A *damper* is sometimes so acted upon by a pressure gauge as to regulate the draught of the furnace, and prevent any great deviation of the pressure from a given intensity. This is accomplished in Watt's low pressure stationary boilers, by having a pressure gauge consisting of a vertical column of water contained in a tube which is open at the top, and plunges into the water within the boiler at the bottom; while a float on the surface of that water column opens the damper when falling, and closes it when rising.

XIX. *Stays* are bars, rods, bolts, and gussets for strengthening the boiler, which have already been mentioned in Article 66, and will be further referred to in a subsequent Article.

XX. *Clothing* for the outer surface of a boiler, to prevent waste of heat, is made sometimes of a layer of coarse felt, covered with a layer of thin wooden boards, and sometimes of a casing of brickwork. The tops of land boilers, resting on brickwork, are sometimes buried under a layer of ashes; but this method is objectionable, as the moisture which collects amongst the ashes tends to corrode the boiler shell.

The principal parts and appendages of engines and boilers having been enumerated and described generally, those which require it will now be treated of in a more detailed manner.

306. *Grate*.—The area of the grate is regulated by the weight of fuel which is to be burnt upon it in an hour, and by the *rate of combustion* per square foot of grate, as to which, see Article 232. To the list of different rates which occur in practice, as given in that Article, at page 285, may now be added the following, which comes between Nos. 1 and 2 of that list:—

	Lbs. per square foot per hour.
1 A. Rate of combustion in the furnace of Craddock's boiler,	} 6 to 10

As has been already more fully explained in Chapter II., the

economy of fuel depends very much on the proper adjustment of the rate of combustion per square foot of grate to the draught of the furnace. A certain rate of combustion, which may be found by practical trials, is the best suited to insure perfect combustion in a given furnace; and this fixes the best area of grate: if the grate is made smaller, the combustion becomes imperfect: if larger, too much air enters, and heat is wasted in warming it. It is best, in practice, to make the grate-area at first rather too large, and then to contract it by means of fire-bricks, until the smallest area is obtained upon which the required quantity of coal can be burned without incomplete combustion.

When air is admitted above the fuel to burn the coal gas, a smaller area of grate is required to burn a given quantity of fuel per hour, than when the whole supply of air has to pass through the grate. For an example of this, see the Table in Article 232, page 285, Nos. 5 and 6.

The *length* of a grate should not much exceed 6 feet, in order that the fireman may easily throw coals to the back of it. It may be as much *less* than 6 feet as the dimensions and figure of the boiler require. The *breadths* of grates range from about 15 inches to 4 feet; the most convenient breadths for firing being from 18 inches to 2 feet, or thereabouts. The grates of stationary and marine boilers are usually long and narrow; those of locomotive boilers are usually almost square, and sometimes round.

To facilitate the even spreading of the fuel, the surface of an oblong grate is in general made to *slope downwards* from the furnace mouth to the bridge at the rate of about *one in six*. Its clear height above the floor of the ash-pit should be at least $2\frac{1}{2}$ feet in front.

A locomotive grate is usually level; and the place of an ash-pit is supplied by a rectangular wrought iron pan about 10 inches deep, which is open at the front, to catch the air as the engine rushes through it, and can be removed when required.

A grate consists of *fire-bars*, and of *cross bearers* by which they are supported. The fire-bars are made in lengths of from 2 to 3 feet. They are from $\frac{5}{8}$ inch to $\frac{3}{4}$ inch broad on the top, and are often made to diminish to about half that thickness at the lower edge, in order to admit of the free entrance of air and escape of ashes. Their ordinary depth is about 3 inches. The breadth of the clear space between two bars is from one-half to two-thirds of the greatest breadth of a bar. At each side of each end of a bar there are snugs or projections, by which the breadth of the bar at its ends is increased so as to be equal to the distance from centre to centre of the bars. When the bars are laid upon the cross bearers with the snugs touching each other, the proper spaces are

left between their intermediate parts. Fire-bars are often cast in pairs, so that two bars with the proper space between them form one piece. This saves time in removing and replacing them when the grate requires repairs.

307. **Moving Grates.**—Reference has been made in Article 230, page 283, to contrivances for supplying fuel to furnaces gradually and equably by mechanism, in order to insure complete combustion. Some of these inventions involve the use of moving grates. The *revolving grate* is circular and horizontal, and turns slowly about its centre. The fuel is dropped upon it by degrees through a fixed opening; and thus every part of it is at all times equally covered. *Juckes's grate* consists of an endless web of very short fire-bars, moving on horizontal rollers, travelling from the furnace mouth to the bridge, and returning through the ash-pit. The portion of the web which at any time is uppermost, is supported on small wheels with which the bars are provided, and which rest on rails. Sometimes the fire-bars, by means of cams, are made to have a short reciprocating motion up and down, and from side to side, in order to keep them clear of clinkers.

308. **Height of Furnace.**—The clear height of the "crown" or roof of the furnace above the grate bars is seldom less than about 18 inches, and often considerably more. In the fire-boxes of locomotives it is on an average about 4 feet.

The height of eighteen inches is suitable where the crown of the furnace is a brick arch, as in Mr. C. T. Dunlop's *detached* furnaces, formerly referred to. Where the crown of the furnace, on the other hand, forms part of the heating surface of the boiler, a greater height is desirable in every case in which it can be obtained; for the temperature of the boiler plates, being much lower than that of the flame, tends to check the combustion of the inflammable gases which rise from the fuel. As a general principle, a *high furnace is favourable to complete combustion.*

The height of the furnace is limited in practice, sometimes by the necessity for having flues or tubes traversing the water above it; and always by the necessity for having a sufficient depth of water above the crown; that is to say, about 12 or 15 inches in marine boilers, 5 or 6 inches in locomotive boilers, and 10 or 12 inches in land boilers.

309. **Hearth for Burning Wood.**—According to M. Pelet, the best furnace for burning wood under a steam boiler consists of a hearth of fire-brick, with a sort of *hopper* or feeding passage in front, of the full width of the hearth, made of cast iron. The wood, cut into billets whose length is a little less than the width of the hearth, is placed crosswise in the hopper, and descends gradually either by its weight alone, or by its weight aided by the pressure of

the feet of the stoker. As it reaches the hearth billet by billet, it takes fire, and is completely consumed. The hearth has a slight slope forwards, towards the bottom of the hopper. The whole supply of air for the combustion of the wood passes down through the hopper amongst the unconsumed billets of wood. The ashes are swept away by the draught.

310. Dead Plate—Mouthpiece—Fire Door—Furnace Front—Ash-pit Door.—The use of the dead plate has been stated in Article 230, page 282. In some of Watt's furnaces, it was nearly as long as the grate; but a length of about 20 inches has been found to answer well in some recent practical examples. When the dead plate forms the bottom of a cast iron mouthpiece, it is useful to make the roof of that mouthpiece slope downwards towards the furnace at the rate of *one in six*, or thereabouts. This has the effect of directing any current of air which may enter through the mouthpiece downwards upon the surface of the burning fuel, so as at once to promote rapid combustion of the coal gas, and to prevent that current from striking the crown of the fire-box, which, when that crown is part of the boiler-surface, tends both to lower its temperature, and to oxidate the plates. In some furnaces the sides and top of the mouthpiece are made thick enough to be traversed by a row of longitudinal holes, each $\frac{1}{2}$ inch in diameter. These holes admit small currents of air, which have some effect in burning the coal gas, but whose principal use is at once to keep the mouthpiece cool, and to carry back to the furnace the heat which would otherwise be lost by conduction through the metal of the mouthpiece.

In some furnaces the dead plate is double, and a current of air is admitted through the passage.

As to contrivances for preventing waste of heat through the fire-door and furnace-front, and for admitting air through them to burn the coal gas, and regulating the admission of that air, and of the air which enters through the ash-pit, see Article 228, page 279, and Article 230, pages 282, 283. To what has been stated there, it may be added, that doors consisting of several layers of wire gauze have lately been used for these purposes, and it is said with good effect; and also, that a heap of dross, slack, or sawdust (where those substances are burned), blocking up the mouthpiece, which is without a door, has been found to answer the same end extremely well in stationary boilers at St. Rollox chemical works. The heap so placed intercepts the radiant heat, and admits through its interstices enough of air to carry the sensible part of that heat back into the furnace, and to burn the gases distilled from the fresh fuel. When the fireman considers that the heap is sufficiently coked or charred, he pushes it forward and spreads it uniformly

over the grate, and supplies its place by blocking the mouthpiece again with a heap of fresh fuel.

311. **Air Passages—Blowing Apparatus—Chimney.**—The means of producing a current of air through a furnace, and the principles of the action of those means, and their peculiar effects, have already (with the exception of the blast pipe) been considered in Articles 230, 231, 232, 233, and 234. It may now be added, that care should be taken not to direct streams of fresh air against the plates or other metal surfaces of the boiler; because if so directed, they produce rapid oxidation.

The blast pipe will be treated of in greater detail amongst some special subjects relating to locomotive boilers.

312. **Strength and Construction of Boilers.**—The principles upon which the strength of boilers depends have already been stated in Section 8 of the Introduction, Articles 59, 60, 61, 62, 63, 66, 67, 68, 69, and 73.

The only figures for the *shells* of boilers which are safe against bursting by internal pressure, without the aid of stays, are the cylinder and the sphere, as to which see Articles 62, 63.

Portions of boiler-shells which are flat, or which otherwise deviate from the cylindrical and spherical figures, are strengthened by means of stays, as to which see Article 66. To the information there given, it may be added, that the usual *pitch* or distance apart of the stays of locomotive fire-boxes is about $4\frac{1}{2}$ or 5 inches, and of marine and stationary boilers 12 to 18 inches. According to Mr. Bourne, the staying of existing marine boilers is seldom sufficiently strong; and the iron of the stays ought not to be exposed to a greater working tension than 3,000 lbs. on the square inch, in order to provide against their being weakened by corrosion. This amounts to making the *factor of safety* for the working pressure about 20.

If any part of the surface of a boiler cannot be efficiently stayed by rods reaching across to the opposite part, it may be fastened by bolts or rivets to a series of ribs crossing it, care being taken that the ends of those ribs have sufficient support. For example, the flat crown of a locomotive fire-box is hung by bolts from a series of parallel ribs, which cross it at distances of from $4\frac{1}{2}$ to 5 inches from centre to centre, and whose ends are supported on the front and back of the fire-box.

It has been found by experience that a thickness of about $\frac{3}{8}$ of an inch is the most favourable to sound rivetting and caulking of boiler-plates; and therefore they are seldom made much thicker or much thinner than that thickness. If a cylindrical boiler is required to withstand a very high pressure, the necessary increase of strength must be attained, not by increasing the thickness of the

plates, but by diminishing the diameter of the shell. The strongest boilers are those which are entirely composed of tubes and small cylinders, with the water and steam inside.

Mr. Fairbairn's experiments have shown (as stated in Article 66), that the stay-bolts of locomotive fire-boxes should have their diameters equal to double the thickness of the plates, if these are of iron, so that for $\frac{3}{8}$ inch iron plates the stay-bolts should be $\frac{3}{4}$ inch in diameter. According to the principles laid down by Mr. Bourne, the factor of safety for the stays of marine boilers should be about three times the factor of safety for those of locomotive boilers; hence for plates of $\frac{3}{8}$ inch thick or thereabouts, the stays of marine boilers, if round, should be about $1\frac{1}{2}$ inch in diameter.

The flat ends of cylindrical boilers are made about once and a-half the thickness of the cylindrical barrels, and are tied to each other by longitudinal stays, or to the sides of the boiler by gussets (see Art. 66.) A pair of tube-plates are tied together in the same manner; and it is safer to rely altogether on stay-rods, to prevent them from being forced asunder, than to leave any part of the tension to be borne by the tubes.

Tubes for the passage of flame and hot gas are made of brass or of iron, and are from $1\frac{1}{2}$ to 2 inches in diameter for locomotives, and from 2 to 4 inches in diameter for marine boilers. They are fixed tight in the holes in the tube-plates, either by driving ferules into their ends, or by rivetting up the edges of the ends themselves, so as to make them fit countersunk grooves which surround the holes on the outside of each tube-plate.

The principles of the strength of cylindrical internal flues have been explained in Article 67.

The flat ends of cylindrical boilers are very commonly connected with the barrels and flues by means of rings of angle iron; but such rings are liable to split at the angle; and therefore it is considered preferable to make the connection by bending the edges of the endmost plates of the barrel and flues. A flat end to a cylindrical shell, or a flat top to a cylindrical steam chest, connected by means of an angle iron ring alone, without stay-bars or gussets, is dangerous at high pressures, even when of small diameter; as the angle iron ring, although it may last for a time and be apparently safe, is almost certain to split at the angle in the end.

The shells of stationary and locomotive boilers are usually single-riveted—those of marine boilers usually double-riveted—that is, the rivets form a zig-zag line at each joint. Horizontal overlapped joints should have the overlapping edges facing upwards on the side next the water, that they may not intercept bubbles of steam on their way upwards. The joints in horizontal flues should be so placed that the overlapping edges shall not oppose the current of gas.

Those parts of boilers which are exposed to more severe or more irregular strains than the rest, or to a more intense heat, should be made of the finest iron, such as Bowling or Lowmoor. This applies to the sides and crowns of internal furnaces, to tube-plates, to bent plates at the ends of cylindrical shells, &c.

313. **Heating Surface—Dimensions and Course of Flues.**—In Article 234, Division IV., there have already been given several examples of the proportions usually borne by the area of heating-surface to the area of the grate, and to the number of pounds of fuel burnt in an hour; and in that Article, and the previous Articles 219, 220, and 221, have been explained the principles on which the efficiency of that heating-surface depends. The object of the use of *tubes* is to obtain a large heating-surface within a moderate space; and this was the nature of the improvement introduced by Booth and Stephenson into the construction of the heating-surface of locomotive boilers. The construction which insures the greatest known heating-surface relatively to the fuel consumed, is that in which the boiler consists mainly of a sort of cage of vertical water-tubes enclosing the furnace, as in Mr. Craddock's boiler, where there are from *six* to *ten* square feet of heating-surface for each pound of coal burned per hour; and the efficiency is accordingly greater than that of any other boiler which has yet been brought into continuous practical operation on the large scale. (See Article 234, Example IX., page 297.)

Similar proportions of heating-surface to fuel consumed may be obtained by means of square water-tubes or cells, each containing four hot gas tubes, as in Mr. J. M. Rowan's boiler.

The *sectional area of the flues* of a boiler must not be made too large, lest it should make the boiler too bulky, nor too small, lest it should cause too much resistance to the draught. Experience has shown, that a sectional area of from *one-fifth* to *one-seventh* of the area of the grate answers well in practice. Where there is a bridge contracting the entrance to the flue, this applies to the area of the passages left by the bridge. In multitubular boilers, the area to be considered is the *joint area of the whole set of tubes*, which, when there are ferules at their ends, is to be measured *within the ferules*.

The course taken by the current of hot gas through the flues and tubes of a boiler is most commonly from below upwards on the whole, even when most of those passages are horizontal. It was first shown by Peclet, and is now generally recognized, that a great advantage in point of thorough convection of heat, and consequently in economy of fuel, is gained by causing the course of the hot gas to be on the whole from *above downwards*; because then the hottest strata of the furnace gas, being uppermost, spread them-

selves out above the denser and colder strata which are below, and so diffuse themselves more uniformly throughout all the passages than they do when made to ascend from below. This principle was practically applied in the Earl of Dundonald's boiler—as to which see Article 234, Example X., page 298, also Article 334, page 476.

314. **Total and Effective Heating Surface.**—The lower horizontal or nearly horizontal surfaces of internal flues and tubes, owing to the difficulty with which bubbles of steam escape from them, are found to be much less effective in producing steam than the lateral and upper surfaces. It is therefore common amongst engineers to distinguish between the *total* heating surface of a boiler and the *effective* heating surface, from which latter the bottoms of internal flues, and *one-fourth* of the surface of each cylindrical horizontal tube are excluded. On an average, the effective heating surface is from $\frac{2}{3}$ to $\frac{3}{4}$ of the total heating surface.

In all the calculations of Article 234, it is the *total heating-surface* which is considered.

315. **Water-Room and Steam-Room** are the names given to the volumes of water and steam respectively contained in the boiler when the surface of the water is at its proper mean level. Authorities differ as to the relative proportions of water-room and steam-room adopted in the practice of the most skilful engineers. According to Mr. Bourne, of the whole *boiler-room*, or internal capacity of the boiler, there are very nearly

$\frac{3}{4}$ water-room, and $\frac{1}{4}$ steam-room.

According to Mr. Robert Armstrong, there are

$\frac{1}{2}$ water-room and $\frac{1}{2}$ steam-room ;

and that author considers that, with a less proportion of steam-room, there is risk of *priming*, or carrying over liquid water from the boiler to the cylinder.

A cylindrical boiler is usually filled with water to three-fourths of its depth or thereabouts.

The practice with regard to the absolute capacity of boilers varies very much. According to Mr. Robert Armstrong, that capacity ought to be—

For each cubic foot of water evaporated per hour,

Steam-room,.....	13 $\frac{1}{2}$	cubic feet.
Water-room,	13 $\frac{1}{2}$	„
	27	„
Total boiler-room,.....	27	„

The number of cubic feet of water to be effectively evaporated per hour in a given engine, per indicated horse-power, is given by the formula,

$$\frac{1980000}{62\frac{1}{2} U}; \dots\dots\dots(1.)$$

where U is the work of one lb. of steam, found by the methods of Chapter III., Sections 5 and 6.

A useful mode of comparing the capacities of different boilers is to divide the boiler-room, in cubic feet, by the area of heating-surface, in square feet. Thus is obtained a sort of *mean depth* in feet, analogous to the hydraulic mean depth of a pipe. Of the following examples, the first three are given on the authority of Mr. Fairbairn's "Useful Information for Engineers."—

	" Mean depth." Feet.
Plain cylindrical egg-ended boiler, with external flues below and at each side, but no internal flues,.....	3'50
Cylindrical boiler with external flues, and one cylindrical internal flue,.....	1'65
Cylindrical boiler with external flues, and two cylindrical internal flues,.....	1'00
Stationary boilers according to Mr. Robert Armstrong's rules,.....	3'00
Multitubular marine boilers, about.....	0'50
Locomotive boilers, and boilers composed of water-tubes, average about.....	0'10

Boilers of large and small capacity have each their advantages. In favour of large capacity are, steadiness in the pressure of the steam, ready deposition of impurities, space for the collection of sediment, freedom from priming. In favour of small capacity are, rapid raising of the steam to any required pressure, small surface for waste of heat, economy of space and weight (which are of special importance on board ship), greater strength with a given quantity of material, smaller damage in the event of an explosion.

In boilers of very small capacity in proportion to their area of heating surface, especially those composed of small water-tubes, it is desirable, and in some cases necessary, to work with distilled water, in order to avoid the priming, the choking of the water-spaces by salt or sediment, and the consequent burning of the iron, which would arise from the use of water containing salt, mud, or other impurities. For that purpose *surface condensation* must be employed, which has already been treated of to a certain extent in Article 222, and will be further considered in the sequel.

316. Feed and Blow-off Apparatus — Donkey-Engine — Brine Pumps.—The feed-pumps are worked by the engine itself when it is in motion; but when it is standing still, and it becomes necessary to feed the boiler, they are driven either by hand, or by a small auxiliary engine called a "*Donkey*." For all marine boilers of considerable size, a donkey-engine is necessary; and it is used not merely to feed the boiler, but to drive the starting and reversing gear of the valves when required, and perform other miscellaneous duties.

To provide for leakage of water and steam, priming, blowing-off, and loss by the safety valves, the feed-pump of a land engine should be of such capacity as to discharge from *double to two and a-half times the net feed-water* required by the engine, according to

Article 284, Equation 10, page 389, }
 Article 287, Equation 17, page 401, } as the case
 or Article 297, Equation 12, page 434, } may be.

In marine engines, a further addition to the capacity of the feed-pumps must be made, to provide for the brine which is blown off or pumped out. Ordinary sea-water contains about $\frac{1}{10}$ of its weight of salt. The brine in the boiler should never be allowed to rise above *treble* that strength; and for that purpose the volume of brine discharged should be equal to *half the volume of the net feed-water*. But it is better still to provide that the brine in the boiler shall never rise above *double* the strength of ordinary sea-water; and for this purpose the brine discharged should be *equal to the feed-water in volume*. The result is, that the discharging capacity of the feed-pumps of a marine engine is made equal to *from three to four times the volume of the net feed-water*. There is, besides, a duplicate set of feed-pumps, in order that if one breaks down the other may be used.

As to the effect of salt in water on its boiling point, see Article 206, Division VIII., page 242.

The brine is discharged at a temperature on an average 140° or 150° higher than that at which the feed-water is drawn from the hot-well. In order that the apparatus of tubes and casing already mentioned under head IX. of Article 305 may act with the greatest possible efficiency in transferring heat from the hot brine to the feed-water, it appears, by the application of equations 6 and 7 of Article 219, that the surface of the tubes should amount to about $\frac{1}{10}$ th of a square foot per lb. of brine discharged per hour; or $6\frac{1}{2}$ square feet per cubic foot of brine discharged per hour.

It may, however, be sometimes difficult or inconvenient in practice to obtain so large a surface.

317. Safety Valves.—(See also Article 113.)—It is considered

desirable that one at least of the safety valves of a boiler should be loaded directly, and not through the medium of a lever.

In stationary engines the load, whether applied through a lever or to the valve directly, consists usually of weights; and weights are used for the same purpose in marine engines also. In locomotives, whose oscillations render weights inapplicable, the load is applied through a lever, by means of a spiral spring contained in a cylindrical case, like that of the indicator (fig. 16, page 47). One end of the spring is attached to the boiler, the other to the lever, by means of a rod whose effective length can be adjusted by a screw and nut; an index pointing to a scale marked on the case shows the tension exerted by the spring. This mode of loading is now frequently adopted for the valves of marine boilers. A valve may also be loaded directly by means of a spring.

In a directly loaded safety valve introduced by Mr. Nasmyth, the valve is a sphere, and has a load hung to it *inside the boiler*. Mr. Fairbairn loads the safety valve by a weight and lever inside the boiler.

The rules followed in practice for the size of the orifice of a safety valve are very various. That given by Mr. Bourne is equivalent to the following:—Let A be the area of the piston; V , its velocity in *feet per minute*; P , the excess of the pressure in the boiler above that of the atmosphere, in lbs. on the square inch. Let a be the required area of the safety valve; then

$$a = A \cdot \frac{V}{300 P} \text{ nearly} \dots \dots \dots (1.)$$

Another mode of determining the size of the orifice has reference to the rate of consumption of fuel, and consists in making

$$a \text{ in square inches} = \text{from } \frac{1}{16} \text{ to } \frac{1}{8} \text{ of the number of lbs. of coal burned per hour} \dots \dots \dots (2.)$$

This rule is applicable to boilers in which the weight of water actually evaporated per lb. of coal is about 6 lbs.; consequently we may substitute for it the following:—

$$a \text{ in square inches} = \text{from } \frac{1}{16} \text{ to } \frac{1}{8} \text{ of the water actually evaporated per hour} \dots \dots \dots (3.)$$

Another rule is

$$a = \frac{1}{8} \text{ square inches} \times \text{nominal horse-power} \dots \dots (4.)$$

Nominal horse-power will be defined in Article 336, page 479.

318. **Steel Boilers.**—Recent improvements in the manufacture of steel have so far diminished its cost as to render it commercially

available as a material for boilers. Its tenacity is on an average about 1.6 times that of iron; and hence, by its use, boilers of a given strength may be made much lighter than heretofore. In the steel steamer "Windsor Castle," lately built by Messrs. Caird & Co., the shell of the boiler is made of steel plates, with steel rivets. It has to withstand a working pressure of about 40 lbs. on the square inch; while its thickness is only $\frac{1}{8}$ inch, or little more than $\frac{1}{2}$ of the thickness of an iron boiler of the same strength.

319. **Proving Boilers.**—Before any boiler is used, its strength ought to be tested by means of the pressure of water, forced in by pumps. The *testing pressure* (according to the principles of Articles 59 and 60) should be *not less than double the working pressure, and not more than half the bursting pressure*; that is to say, as the bursting pressure should be six times the working pressure, the testing pressure should be between twice and three times the working pressure. About *two and a-half* times the working pressure is a good medium.

In everything that relates to the strength and testing of boilers, the "*pressure*" is to be understood to mean the *excess of the pressure within the boiler above the atmospheric pressure*, as in Article 294.

The pressure of water is to be used in testing boilers, because of the absence of danger in the event of the boiler giving way to it.

320. **Explosions** of steam boilers, so far as they are understood, arise and are to be prevented in the following manner:—

I. From original weakness. This cause is to be obviated by due attention to the laws of the strength of materials in the designing and construction of the boiler, and by testing it properly before it is subjected to steam pressure.

II. From weakness produced by gradual corrosion of the material of which the boiler is made. This is to be obviated by frequent and careful inspection of the boiler, and especially of the parts exposed to the direct action of the fire.

III. From wilful or accidental obstruction or overloading of the safety valve. This is to be obviated by so constructing safety valves as to be incapable of accidental obstruction, and by placing at least one safety valve on each boiler beyond the control of the engineman.

IV. From the sudden production of steam of a pressure greater than the boiler can bear, in a quantity greater than the safety valve can discharge. There is much difference of opinion as to some points of detail in the manner in which this phenomenon is produced; but there can be no doubt that its primary causes are—first, the overheating of a portion of the plates of the boiler (being in most cases that portion called the *crown of the furnace*, which is directly

over the fire), so that a store of heat is accumulated—and, secondly, the sudden contact of such overheated plates with water, so that the heat stored up is suddenly expended in the production of a large quantity of steam at a high pressure. Some engineers hold, that no portion of the plates can thus become overheated, unless the level of the surface of the water sinks so low as to leave that portion of the plates above it, and uncovered; others maintain, with M. Boutigny, that when a metallic surface is heated above a certain elevated temperature, water is prevented from actually touching it either by a direct repulsion, or by a film or layer of very dense vapour; and that when this has once taken place, the plate, being left dry, may go on accumulating heat and rising in temperature for an indefinite time, until some agitation, or the introduction of cold water, shall produce contact between the water and the plate, and bring about an explosion. All authorities, however, are agreed, that explosions of this class are to be prevented by the following means:—1. By avoiding the forcing of the fires, which makes the boiler produce steam faster than the rate suited to its size and surface. 2. By a regular, constant, and sufficient supply of feed water, whether regulated by a self-acting apparatus, or by the attention of the engineman to the water gauge; and 3, Should the plates have actually become overheated, by abstaining from the sudden introduction of feed water (which would inevitably produce an explosion), and by drawing or extinguishing the fires, and blowing off both the steam and the water from the boiler.

321. Internal Deposits.—Boilers are liable to become encrusted inside with a hard deposit of the minerals contained in the water, which, by resisting the conduction of heat, impairs at once the evaporative power of the boiler, its durability, and its safety. The deposition of carbonate of lime can be prevented by dissolving sal-ammoniac in the water; for that salt and the carbonate of lime are mutually decomposed, producing carbonate of ammonia and chloride of calcium, of which both are soluble in water, and the former is volatile. The deposition of sulphate of lime can be prevented by dissolving carbonate of soda in the water; the products being sulphate of soda and carbonate of lime, of which the former is soluble, and the latter falls down in grains, and does not adhere to the boiler. The most effectual means of preventing internal incrustation are, either a regular system of blowing off the water before it becomes too highly charged with impurities, like that described in Article 316; or the use of water so pure as to yield no deposit; whether such water be obtained from a natural source, or by means of surface condensation.

A peculiar deposit of an unctuous nature has been found to clog

the water spaces of the boilers of some of the engines in which surface condensation has been employed. That deposit consists of the grease or oil used to lubricate the cylinder, partially altered and decomposed. It can be obviated by introducing little or no grease or oil into the cylinder; and to make that practicable, the surface of contact between the packing of the piston and the interior of the cylinder must be lubricated with water. In order that a small quantity of water may remain in the cylinder in the liquid state for that purpose, the heating of the steam, whether by means of a superheating apparatus or of a steam jacket round the cylinder, must not be carried so far as wholly to prevent condensation in the cylinder. On this point, see Article 286, page 396.

322. An **External Crust** of a carbonaceous kind is often deposited from the flame and smoke of the furnaces in the flues and tubes, and if allowed to accumulate, seriously impairs the economy of fuel. It is removed from time to time by means of scrapers and wire brushes. The accumulation of this crust is the probable cause of the fact, that in some steam-ships the consumption of coal per indicated horse-power per hour goes on gradually increasing, until it reaches one and a-half its original amount, and sometimes more. The following is an example of that increase, from an ocean steamer of great size and power:—

	Coal per I. H.-P., per hour. Lbs.
On trial trip,	3.5
On 1st day of voyage,.....	3.6
On 5th day,.....	4.68
On 11th day,.....	4.55
On 26th day,.....	5.32
On 30th day,.....	5.84
On 32d day,.....	4.65
On 35th day,.....	6.10

The increase in the consumption of fuel, although not absolutely continuous, and sometimes even reversed to a small extent, is still sufficiently marked to prove a progressive falling off in the efficiency of the furnace and boiler.

323. **Nominal Horse-power of Boilers.**—Boilers, especially those of stationary engines, are sometimes stated to be of so many *horse-power*. This is, in fact, a conventional mode of describing the *dimensions* of the boiler, according to an arbitrary rule. The rules employed for estimating the nominal horse-power of boilers have been various, and most of them vague and indefinite. A perfectly definite rule, however, has been proposed by Mr. Robert Armstrong, as being founded on the best ordinary practice, viz:—

Take a mean proportional between the area of the fire grate in square feet, and the area of the effective heating surface in square yards.

The nominal horse-power of the boiler is generally much less than the indicated horse-power of the engine, to which it bears no fixed proportion.

SECTION 2.—*Examples of Furnaces and Boilers.*

324. **Wagon Boiler.**—This form of boiler, which is suitable for

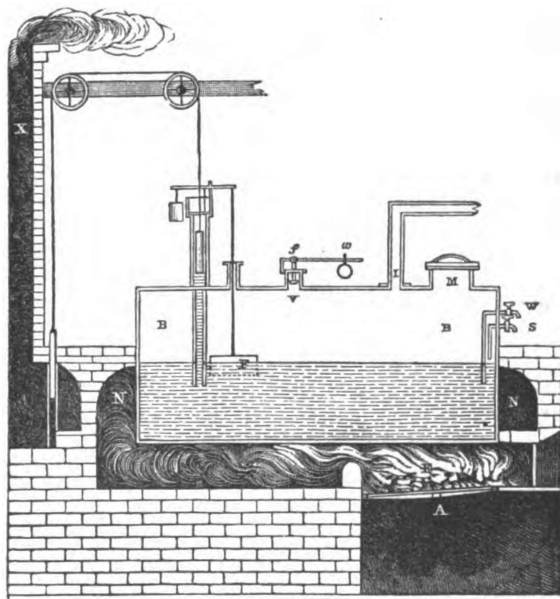

Fig. 116.

low pressure steam only, was introduced by Boulton and Watt, and was for a long time the most generally used of all boilers. A great number of wagon boilers are still in use, but as their manufacture has been almost, if not wholly, given up, they will probably disappear by degrees.

Fig. 116 is a longitudinal section, showing the general arrangement of the principal appendages of the boiler; fig. 117 a cross-section.

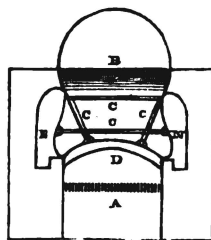

Fig. 117.

C, C, C, C, stay-rods; D, the bridge; N, N, flues. The flame or furnace gas proceeds from the furnace over the bridge, and backwards along the flue below the boiler; it returns forwards along one of the lateral flues N, and again proceeds backwards along the other lateral flue to the chimney. This course of the hot gas is called a *wheel-draught*. In the figure the boiler has no internal flue; sometimes there is a cylindrical internal flue, along which the hot gas returns forwards, and then divides into two currents, which proceed backwards to the chimney along the lateral flues. This is called a *split-draught*.

W and S are water-gauge cocks; M, the man-hole; I, the steam pipe; V, the safety valve; F is the stone float, partially counterpoised, whose rising and falling regulates the valve for the admission of the feed-water. The column of water in the vertical feed-pipe in these old low-pressure boilers acts as a pressure gauge, and a float on the surface of that column is seen to be connected by a chain over a pulley with the damper, whose opening it regulates.

325. **Cylindrical Egg-Ended Boiler.**—This boiler consists simply of a cylindrical shell with hemispherical ends.

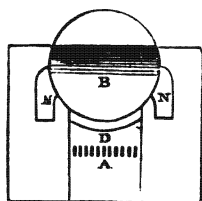

Fig. 118.

Its figure is very favourable to strength and safety, with a high pressure; but it requires great length as compared with other boilers to give sufficient heating surface. In the cross-section, fig. 118, A is the grate, occupying a length which ought not to exceed about six feet under the front end of the boiler; B, the boiler; D, the bridge, made concave at the top so as to be parallel to the bottom of the boiler; N, N, the flues, through which the hot

gas forms a *wheel-draught*, as in Article 324.

This boiler, like the wagon boiler, is sometimes made with an internal flue, by which the deficiency of heating surface compared with capacity is to a certain extent made up.

A serious defect of the cylindrical boiler with the furnace below it is, that the bottom of the boiler where sediment collects is the part exposed to the most intense heat. Unless, therefore, the water used is of uncommon purity, the bottom of the boiler is liable to burn. Cylindrical boilers are sometimes made without lateral flues; the hot gas flowing straight along the bottom of the boiler from the furnace to the chimney. This arrangement is called a "flash flue." It requires a greater length for a given heating surface than any other form of boiler.

326. **Retort Boiler.**—This is the name given by Messrs. Dunn & Hattersley to a boiler introduced by them, in order to obtain the strength of the cylindrical egg-ended boiler, without its disadvan-

tages in point of compactness, economy of fuel, and durability. It consists of a number of small cylindrical egg-ended shells laid side by side, parallel and horizontally, above the furnace and flues; these contain water to about three-quarters of their depth, and in them the boiling takes place; they all communicate upwards with one long cylindrical egg-ended shell which acts as a steam chest, and below with another which serves as a sediment collector.

327. **Cylindrical Boiler with Heaters.**—This is called in Britain the “French boiler,” from being much used in France. In France it is called “chaudière à bouilleurs.” Fig. 119 shows a longitu-

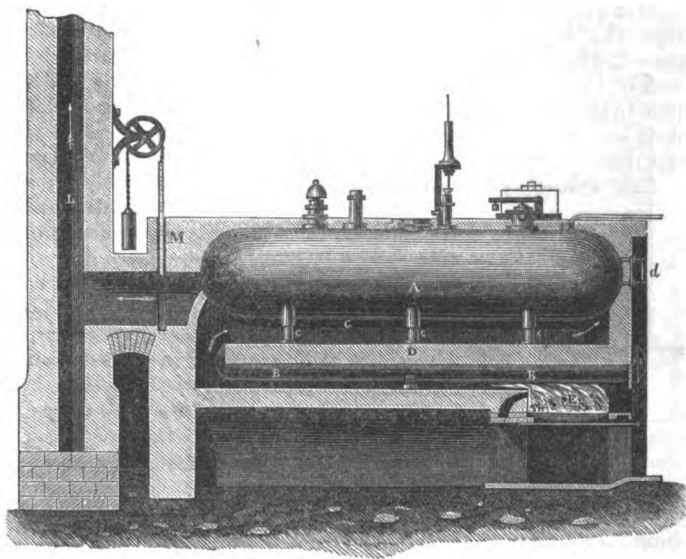

Fig. 119.

nal section of the furnace and flues, and side elevation of the boiler; fig. 120 shows a cross-section of the boiler, furnace, and flues.

A is the main boiler shell, cylindrical, with hemispherical ends; B, B, the heaters, or “bouilleurs,” being horizontal cylindrical shells of smaller diameter than the main shell, having their backward ends hemispherical or segmental, and their forward ends closed by covers, so as to serve as “mud-holes” for the cleansing out of sediment when required; C C C, C C C, are two rows of vertical tubes, which connect the main boiler shell with the heaters. D is a horizontal brick partition, at the level of the

upper halves of the heaters; E, the furnace; F (fig. 120), the passage over the bridge from the furnace to the flame-bed.

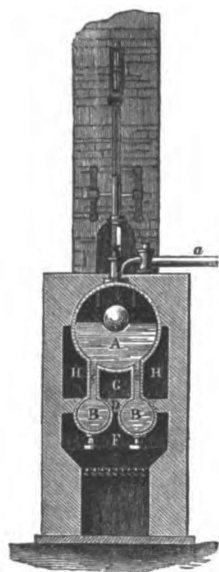

Fig. 120.

The space above the horizontal partition D is divided by two parallel brick partitions, occupying the intervals of the two rows of vertical tubes, into three parallel flues, H, G, H. L is the chimney; M, the damper; *d* is the glass water-gauge in front of the boiler. On the top of the main shell are seen the man-hole, safety valves, and other appendages. In fig. 119, at the back of the furnace, is seen one of a row of curved passages, opened and closed by a sliding valve, for admitting jets of air above the fuel through holes in the front of the bridge; at the front of the furnace is seen a dead-plate.

The flame and hot gas pass backwards through F; then forwards through G; then by a "split-draught," backwards through the lateral flues H, H; and then to the chimney.

This boiler is considered both safe and efficient. In France the heaters and connecting tubes are often made of cast iron; in Britain that material is considered unsafe for boilers.

328. **The Cornish Boiler** in its simplest form consists of a horizontal cylindrical shell B (fig. 121), with an internal cylindrical flue, whose diameter is $\frac{1}{3}$ ths of that of the shell or thereabouts. In the front end of that flue is situated the internal furnace, of which A is the grate, and D the bridge. The external flues may be arranged either for a split-draught or a wheel-draught. The figure shows the arrangement for a split-draught. The current of furnace gas, after having passed backwards over the bridge and along the internal flue, divides

into two streams, which pass forwards along the side flues E, E; then those streams re-unite, and pass backwards along the bottom flue F to the chimney. In this form of boiler the furnace gas takes a descending course, of which the advantages have been stated in Articles 220 and 313; the bottom of the boiler, where the feed-water first mingles with the rest, and where deposit tends to settle, is the coolest portion; and the hottest portion (the

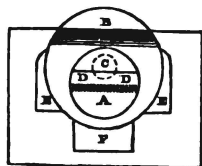

Fig. 121.

crown of the furnace) is near the surface, where the steam is given off. All these circumstances are favourable to durability and economy.

The crown of the furnace, and a portion of the top of the flue beyond the bridge, are sometimes lined with a brick arch, to prevent the flame from being cooled and extinguished by contact with the plates of the boiler before the combustion of the coal gas is complete.

The part of the internal flue behind the bridge is sometimes made a little narrower than the part which contains the furnace.

Boilers of this class have in many cases given way by the collapsing of the internal flue. The principles upon which the strength of that flue depends, discovered by Mr. Fairbairn, have been explained in Article 67, pages 70, 71.

The dotted circle C represents a heater, or horizontal water-tube, like those of the French boiler, which is sometimes placed within the internal flue of the Cornish boiler, in the part behind the bridge. It is connected by one or more vertical water-tubes, with the water-space at the bottom of the main boiler, and by a siphon-shaped tube, beyond the backward end of the main boiler, with the steam-space at the top.

329. **Cylindrical Double-Furnace Boiler.**—A cross-section of a boiler of this class is shown in fig. 122. The boiler consists of a cylindrical shell, with a pair of similar and parallel internal flues, whose diameter is $\frac{1}{16}$ ths of that of the shell, or thereabouts. Each of these flues contains in its front end an internal furnace, like that of the Cornish boiler. Those furnaces are fired alternately, in order to promote complete combustion, as stated in Article 230, page 282. The external flues form either a wheel-draught (as shown in fig. 122), or a split-draught (as shown in fig. 121).

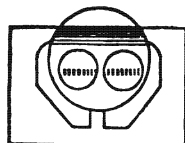

Fig. 122.

In one form of this boiler the two internal flues run parallel to each other from end to end of the boiler. This prevents the mixing of the gases from the two furnaces until they have been considerably cooled; and to remedy that defect, in some boilers a series of transverse tubes have been introduced, at and near the bridges, to make an early communication between the two currents of furnace gas.

In another form, the two flues unite into one at a short distance behind the bridges, so that the entire combination of flues has a forked shape. The combustion-chamber where the flues unite, is sometimes strengthened against collapsing by means of vertical water-tubes traversing it, and acting as hollow pillars or struts, to keep the top and bottom asunder.

330. **Cylindrical Double-Furnace Tubular Boiler.**—This boiler, introduced by Mr. Fairbairn, is like a forked-flue boiler, in which, for the single part of the internal flues, is substituted a set of parallel tubes. The cross-section of the two furnaces is similar to fig. 122. Fig. 123 is a horizontal section of the boiler. A, A, are the grates; B, B, dead-plates; D, D, bridges; E, mixing-chamber or flame-chamber; F, F, front tube-plate; G, tubes; H, H, back tube-plate, and backward end of boiler. According to the usual proportions of this boiler, the length of the tubes is about one-half of the total length of the boiler. It has external flues, like the boiler of the last Article.

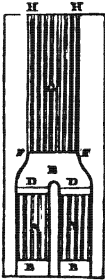

Fig. 123.

331. **Marine Flue Boilers**, as stated in Article 305, are of a shape approximating to rectangular, with the corners more or less rounded, and the top more or less arched: strength to resist internal pressure is given by stays and ribs. Each boiler usually contains two or more internal furnaces, of an oblong rectangular shape, often arched at the top also. These furnaces stand in a row within the boiler, near its bottom. The bridges are sometimes water-spaces, but are more generally of fire-brick. The remainder of the interior of the boiler-shell, up to within about ten inches or a foot of the proper water-level, contains a set of flues, of a form of section nearly rectangular with rounded corners. One of these flues starts from each of the furnaces, and takes a winding course within the boiler, according to the judgment of the designer. Finally, all the flues unite in an ascending flue called the "uptake," which leads to the chimney. The steam chest is usually a rectangular or cylindrical box, sometimes with a hemispherical dome, enveloping the upper part of the uptake and lower part of the chimney, so that the steam may be dried, and in some cases partially superheated.

The variety of forms and arrangements of flues in marine boilers is such as to defy classification. One of the most remarkable forms is the spiral flue, winding round a vertical axis through the water-space and steam-space, which latter ascends to a considerable height, in order to dry and superheat the steam effectually: an invention of Mr. John Elder. The chimneys of marine boilers are sometimes made to lengthen and shorten like the tube of a telescope, so that they can be lowered when the vessel is going under sail only.

332. **Marine Tubular Boilers.**—The general arrangement of parts in this class of boilers is shown in fig. 124, which is a longitudinal section, showing *one furnace*, with its flue, tubes, and communication with the uptake and chimney. Any required number of such

furnaces, according to the breadth of the boiler, may be ranged side by side within the boiler. A, A, is the grate; B, the dead-plate; C, the ash-pit; D, the bridge; E, the rising flue, flame-chamber, or "back uptake;" F, F, F, F, the tube-plates and tubes; G, G, the

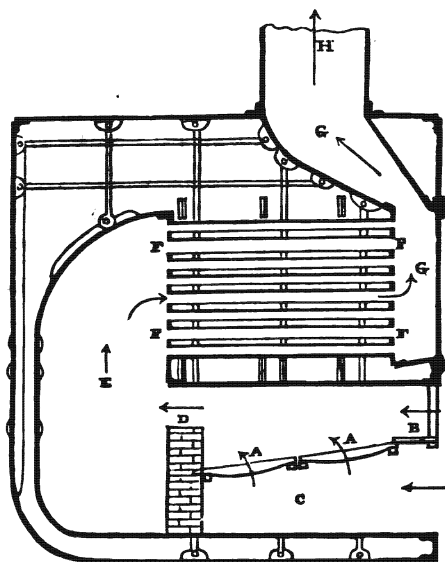

Fig. 124.

uptake, having doors in front for the removal of soot and other dirt, and for access to the tubes to cleanse or repair them; H, the chimney. The figure shows a few of the stay-rod within the boiler.

In the figure, the tubes are represented as horizontal; they are often, however, made to have a slope, parallel or nearly parallel to that of the grate-bars. The height from the furnace-crown to the lowest row of tubes should be sufficient to allow the space between them to be cleansed.

The most usual diameter of marine boiler tubes is, as formerly mentioned in Article 305, three inches; they are sometimes, however, used of smaller diameters, ranging down to $1\frac{1}{2}$ inch internal diameter.

333. **Detached-Furnace Boiler.**—This has already been mentioned in Article 228, page 279; Article 230, page 283; and in Articles 303, 304, and 310, pages 449, 450, and 458. Fig. 125 is a horizontal

section of a double furnace of this kind, used at St. Rollox, showing a small portion of the boiler; fig. 126 is a cross-section of the furnace; fig. 127 a cross-section of the boiler and flues. These three figures are on a scale of $\frac{1}{16}$ of the real dimensions; A, A, are the

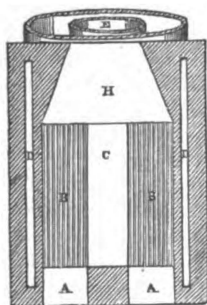

Fig. 125.

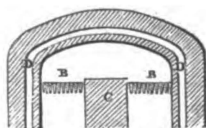

Fig. 126.

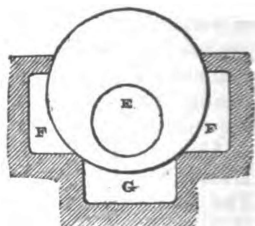

Fig. 127.

dead-plates; B, B, the grates; C, the brick partition between the two grates and their ash-pits; D, D, air-spaces in the brickwork of the sides and roof of the furnace, to resist the conduction of heat; H, flame-chamber, tapering so as to join the internal flue E, of the boiler; F, F, side flues; G, bottom flue.

Fig. 128 is a longitudinal section of a mouthpiece and dead-plate, showing the heap of dross which acts as a fire-door (see Article 310), and the air-holes in the thickness of the top of the mouthpiece. Fig. 129 is a front view of the mouthpiece, showing the air-holes. These two figures are on a scale of $\frac{1}{16}$ of the real dimensions.



Fig. 128.

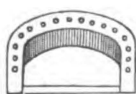

Fig. 129.

In some of the boilers, the internal flue, instead of traversing the boiler from end to end, is of a T-shape at the backward end, the two branches leading into the two side flues F, F. In others, there is a single cylindrical flue for half the length of the boiler, and a set of tubes, as in fig. 123, page 474, for the other half of the length. These forms of flue were introduced by Mr. John Tennent.

334. Miscellaneous Forms of Boiler.—Various kinds of boilers, presenting great diversities of form and arrangement, have already been incidentally mentioned and described generally, such as Mr. Craddock's boiler (Articles 303, 305, 313, 315). With reference to this boiler, it may here be added, that the vertical water-tubes have a portion slightly curved, in order that when expanded by

heat, they may yield sideways, and not strain the framework of the boiler. The Earl of Dundonald's boiler, mentioned in Article 234, Example X., consists of a shell like that of a marine flue-boiler, but somewhat longer and lower. Within that shell are, the furnace, the flame-chamber, and the uptake, all at the same or nearly the same level. The flame passes from the *top* of the furnace into the *top* of the flame-chamber, which is traversed by a great number of vertical water-tubes: from the *bottom* of this chamber the hot gas passes into the uptake, in contact with which is a steam chest communicating at its top with the top of the boiler. At the passage of communication is a centrifugal fan, so placed as to throw the spray that is mixed with the steam back into the boiler.

Amongst vertical tube boilers may be mentioned one of Mr. David Napier's, which has been used to some extent in practice. The shell is cylindrical and vertical, with a hemispherical top. Within it is a vertical cylindrical flame-chamber, and within the flame-chamber are numerous vertical water-tubes, communicating above with the steam space at the top of the boiler, and below with a flattened hollow disc, or "pan," which is above the fire, and is connected by horizontal tubes with the surrounding annular water space.

The *locomotive boiler* will be illustrated along with the engine, in the next chapter.

CHAPTER V.

OF THE MECHANISM OF STEAM ENGINES.

SECTION I.—*Of the Mechanism of Steam Engines in general.*

335. **Engines Classed.**—All steam engines may be divided into two great classes, according as they are or are not provided with apparatus for condensing the steam at a pressure lower than the atmospheric pressure; that is to say, with a *low pressure condenser*, and its appendages. These classes are—

I. *Condensing, or low pressure engines.*

II. *Non-condensing, or high pressure engines.*

The difference between those two classes of engines, in so far as it affects the efficiency of the steam, has been treated of already in Article 280, pages 381, 382, 383, and in Article 289, pages 410, 411. The kind of locomotive mentioned in Article 412, which condenses part of its waste steam at the atmospheric pressure, belongs more properly to the second class than to the first.

Engines of the second class are on the whole less economical of fuel than those of the first class; but as they have fewer parts, and occupy less space, they are much used where simplicity and compactness are considered of more importance than economy of fuel.

A *second* mode of classing steam engines is founded on the mode in which the steam acts upon the piston, and is as follows:—

I. *Single acting engines*, in which the steam performs its work by its action on one side of the piston only.

II. *Double acting engines*, in which the steam exerts energy on either side of the piston alternately.

III. *Rotatory engines*, in which the steam drives a revolving piston round.

The way in which the difference between single and double acting engines affects the calculation of the power has already been explained in Article 43, page 50, and referred to in Article 260, pages 333, 334, Article 263, page 339, and elsewhere.

A *third* mode of classification distinguishes engines into—

I. *Non-rotative*, in which no continuous rotation is produced, as in single acting pumping engines, steam hammers, and direct acting beetling machines.

II. *Rotative engines*, in which the motion is finally communicated to a continuously rotating shaft.

Rotative engines are now the most common. Non-rotative engines are exceptional.

A *fourth* mode of classing engines is founded on their purposes, as follows:—

I. *Stationary engines*, such as those used for pumping water, for driving manufacturing machinery, &c.

II. *Portable engines*, which can be removed from place to place, but are stationary when at work.

III. *Marine engines*, for propelling vessels.

IV. *Locomotive engines*, for propelling vehicles on land.

Stationary engines exist of all the classes belonging to the three previous modes of classification. Portable engines are usually non-condensing, to save space, and to adapt them to situations where injection water cannot be obtained in sufficient quantity. Most of them are also double acting and rotative. Marine engines are in general condensing, double acting, and rotative. Locomotive engines are almost all non-condensing, and all double acting and rotative.

336. **Nominal Horse-power** is a conventional mode of describing the *dimensions* of a steam engine, for the convenience of makers and purchasers of engines, and bears no fixed relation to *indicated* or to *effective* horse-power.

The mode of computing nominal horse-power, established amongst *civil* manufacturers of steam engines by the practice of Messrs. Boulton and Watt, is as follows:—

Assume the velocity of the piston to be 128 feet per minute
 × cube root of length of stroke in feet;

Assume the mean effective pressure to be 7 lbs. on the square inch;

Then compute the horse-power from those fictitious data, and the area of the piston; that is to say,

$$\begin{aligned} \text{Nominal H.-P.} &= 7 \times 128 \times \sqrt[3]{\text{stroke in feet}} \\ &\quad \times \text{area of piston in square inches} \div 33,000 \\ &= \frac{\sqrt[3]{\text{stroke in feet}} \times \text{area piston in inches}}{47 \text{ nearly}} \\ &= \frac{\sqrt[3]{\text{stroke in feet}} \times \text{diam.}^2 \text{ in inches}}{60} \dots\dots\dots(1.) \end{aligned}$$

The indicated power of different engines usually exceeds the nominal power as computed by the above rule in proportions ranging from 1½ to 5.

In the rule established by the *Admiralty* for computing nominal

horse-power, the *real velocity of the piston* is taken into account; but the *fictitious effective pressure* of 7 lbs. on the square inch is assumed; consequently, by the Admiralty rule,

$$\begin{aligned} \text{Nominal H.-P.} &= \text{velocity of piston in feet per minute} \\ &\times \text{area of piston in inches} \times 7 \div 33,000 \\ &= \frac{\text{velocity in feet per min.} \times \text{diam.}^2 \text{ in inches}}{6000} \dots\dots (2.) \end{aligned}$$

The indicated power of marine engines ranges from *once to three times*, and is on an average about *twice* the nominal power as computed by the Admiralty rule.

Both the civil rule and the Admiralty rule for computing the power of engines are applicable to low pressure engines alone. For high pressure engines there is a customary rule proposed by Mr. Bourne, which consists in assuming the effective pressure to be 21 lbs. per square inch, the other data being the same as in the rule for low pressure engines.

337. **Enumeration of the Principal Parts of an Engine.**—I. The boiler and cylinder are connected by means of the *steam pipe*, in which is the *stop valve*, already mentioned in Article 305, Division XI: also, the *throttle valve* or *regulator*, for adjusting the opening for the admission of steam to the cylinder, which in some engines is regulated by hand, and in others by a *governor*, as to which see Articles 55, 56, page 63.

II. The steam pipe contains sometimes also the *cut-off valve* or *expansion valve*, for cutting off the admission of the steam to the cylinder at any required period of each stroke of the piston, leaving the remainder of the stroke to be performed by the expansion of the steam already admitted.

III. The *cylinder* may be single or double acting. In a single acting engine, the *piston* is forced in one direction by the pressure of the steam, and made to return in the opposite direction when the steam is discharged by the action of a weight or *counterpoise*. In a double acting engine, the piston is forced in either direction by the pressure of the steam which is admitted and discharged at either end of the cylinder alternately.

IV. The admission and discharge of the steam take place through openings near the ends of the cylinder, called *ports*, connected with passages called *nozzles*, which are opened and closed by *induction* and *eduction valves*. Sometimes the induction and eduction valves are combined in one valve, called a *slide valve*. The valves are contained in the *valve-chest*.

V. In *non-condensing* engines (conventionally called *high pressure engines*), the waste steam discharged from the cylinder escapes into

the atmosphere through the *blast pipe*; in locomotive engines, as well as some others, the blast pipe is placed in the centre of the chimney, so that the successive blasts of steam discharged from it augment the draught of air through the furnace, and cause the combustion of the fuel to be more or less rapid, according as the engine is performing more or less work.

VI. The *cylinder cover* has in it a *stuffing-box* for the passage of the piston rod; in large engines there are sometimes more than one piston rod and stuffing-box, and sometimes a tubular piston rod, called a *trunk*. The cylinder cover is also provided with a *grease cock*, to supply the piston with unguent.

VII. In many large engines, there is a spring safety valve, called an *escape valve*, at each end of the cylinder; the chief use of which is to discharge water which may condense in the cylinder, or be carried over in the liquid state from the boiler, by what is called *priming*.

VIII. To prevent condensation in the cylinder, it is sometimes enclosed in a casing, called a *jacket*, the intermediate space being filled with hot steam from the boiler, or hot air from a flue (see Article 286).

IX. Outside the jacket, to prevent loss of heat externally, there is a *clothing* of felt and wood.

X. *Double cylinder* engines have two cylinders; the steam being admitted from the boiler into the first cylinder and then filling the second by expansion from the first.

XI. The ordinary *condenser* is a steam and air-tight vessel of any convenient shape, in which the steam discharged from the cylinder is liquefied by a constant shower of cold water from the rose-headed *injection valve*.

XII. In land engines the *injection water* comes from a tank called the *cold well*, surrounding the condenser, and supplied by the *cold water pump*; in marine engines, it comes directly from the sea.

XIII. In the *surface condenser* the steam is liquefied by being passed through tubes or other narrow passages surrounded by currents of cold water, or cold air.

XIV. The condenser is provided with *blow-through* valves, communicating with the cylinder, usually shut, but capable of being occasionally opened, and with a *snifting valve* opening outwards to the atmosphere; through these valves steam can be blown to expel air from the cylinder and condenser before the engine is set to work.

XV. The condenser has also a *vacuum gauge*, to show how much the pressure in it falls below that of the atmosphere (see Article 107 A, pages 110, 111, 112).

XVI. The water, the small portion of steam which remains

uncondensed, and the air which may be mixed with it, are sucked from the condenser by the *air pump*, and discharged into the *hot well*, a tank from which the feed pump, mentioned in Articles 305 and 316, draws the supply of water from the boiler. The surplus water of the hot well in land engines is discharged into a pond, there to cool and form a store of water for the cold well; in marine engines, it is ejected into the sea.

XVII. In all, except certain peculiar classes of engines, there is a *parallel motion* for guiding the head of the piston rod to move in a straight line, consisting either simply of straight cheeks or guides, or of a combination of levers and linkwork, invented by Watt, and more or less modified by others.

XVIII. The peculiar class of engines above excepted, are—first, *trunk engines* (including Mr. Hunt's Z crank engine), where the stuffing-box is the guide; secondly, *oscillating engines*, in which the head of the piston rod is directly connected with the crank, and the cylinder oscillates on trunnions; thirdly, *disc engines*, in which the functions of a cylinder are performed by a vessel of the figure of a spherical zone, and those of a piston by a disc having a motion of nutation in that zone; and fourthly, *rotatory engines*, in which the piston revolves round an axis. Trunk engines and oscillatory engines are of common occurrence in steam-ships. The Z crank engine has not been tried on a large scale. Disc engines are said to answer well, but are of rare occurrence. Rotatory engines of various kinds have been often tried, but seldom with good results.

XIX. In single acting engines for pumping water, the pump rods are worked either by direct connection with the piston rod, or through the intervention of a *beam*.

XX. In double acting engines, the power is communicated to a revolving *shaft*, driven by means of a *crank* and *connecting rod*, with or without the intervention of a *beam*. (In oscillating engines the piston rod and connecting rod are one).

XXI. In stationary engines the shaft carries a *fly-wheel*, to distribute and equalize irregularities in the action of the power by its inertia; this function is performed in marine engines by the inertia of the paddle-wheels or screw, and, in locomotive engines, by the inertia of the driving-wheels and of the engine itself.

XXII. The feed pump, and other pumps which are appendages of the engine, are worked by the mechanism; so also are the induction and eduction valves, through what is called the *valve gearing* or *valve motion*—a part of the machinery which is under the control of the engineman, and so contrived as to enable him to stop and reverse the motion of the engines at will, and whose forms are very various.

338. **Combined Engines.**—Most marine and locomotive engines,

and many stationary engines, have, in order to equalize the action of the power, a *pair* of cranks at right angles to each other, driven by a *pair* of pistons in a *pair* of cylinders, with their appendages ;

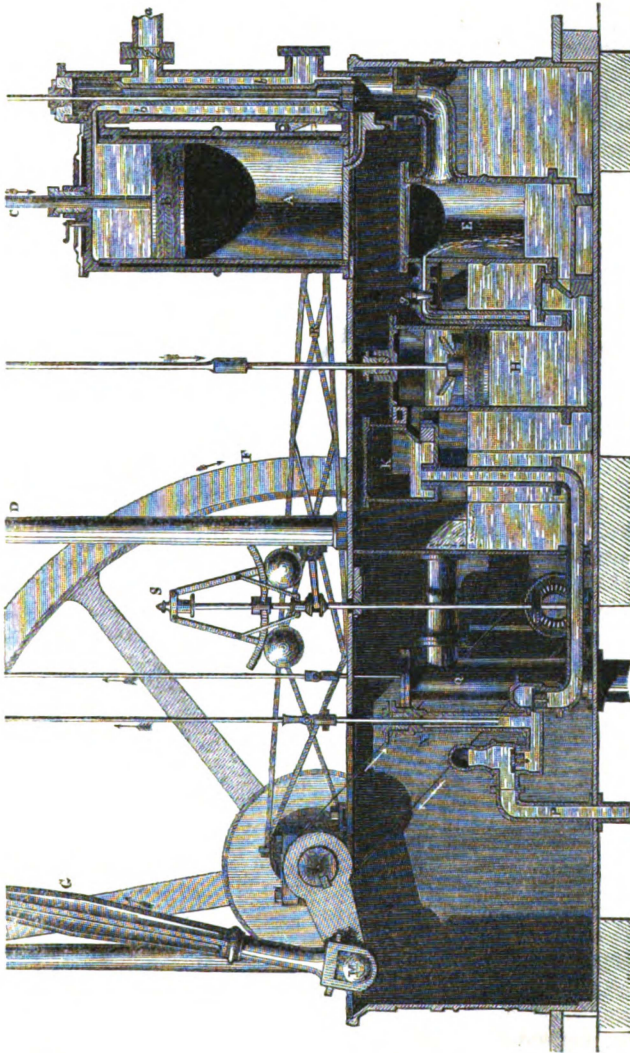

Fig. 130.

and are, in fact, *pairs of engines*. In some cases, engines are similarly combined in sets of *three*, driving three cranks, which make equal angles with each other. As to the effect of these combinations on steadiness of motion, see Article 52, page 60.

339. **Parts of an Engine Illustrated.**—Most of the parts enumerated in Article 387 are illustrated in fig. 130, which represents a longitudinal section of a *rotative double-acting stationary condensing* (or low-pressure) *steam engine*. That kind of engine is selected because the arrangement of its parts is well suited for exhibiting nearly all of them at one view. Amongst the parts omitted, for want of room, the chief are the beam and the parallel motion, which will be illustrated farther on. The main-centre, or axis of the beam, is above the pillar D, and its two ends are respectively above the cylinder A and shaft L.

A is the cylinder, with its jacket, but without clothing, which is a defect in the engine represented.

B, the piston, with three metallic packing-rings. In the figure the piston is supposed to be moving downwards, pressed by the steam which is entering above it.

C, the piston rod.

D, one of the pillars of the frame.

a, steam pipe, with throttle valve.

b, valve chest.

c, slide valve, of the kind called a "*D-slide*," which regulates the "*distribution*" of the steam—that is, its alternate admission and discharge above and below the piston.

d, exhaust-pipe, leading into

E, the condenser.

g, injection cock, admitting a shower of cold water from the cold well, or cold water tank, into the condenser.

H, air pump, the piston of which in the figure is supposed to be descending.

K, Hot well.

G, connecting rod, in the act of rising.

L, shaft; L M, crank; M, crank pin, in the act of right-handed rotation (similar to that of the hands of a watch).

N, feed pump, drawing water from the hot well K. In the engine represented, the supply pipe from the hot well to the feed pump traverses the cold well. That is a fault; for it tends to heat the condensation water, and cool the feed water.

P, feed pipe of the boiler.

Q, cold water pump.

R, eccentric rod, which receives a reciprocating motion from an eccentric wheel on the shaft L, and communicates that motion to the slide valve c.

S, governor, being a double revolving pendulum of the kind mentioned in Article 55, page 63. It is seen to act on a small lever whose axis turns in bearings fixed to the pillar D. The links and intermediate levers by which the motion of that lever is communicated to the throttle valve are not shown, their arrangement being a matter of convenience.

SECTION 2.—*Of Steam Passages, Valves, and Valve Gearing.*

340. **Steam Passages.**—The principle which ought to regulate the size of the steam pipe, and of all passages by which the steam is admitted to the cylinder, has already been stated in Article 290, page 414, viz., that the velocity of the steam should not be greater than 100 feet per second, or 6,000 feet per minute, supposing its density to be the same in the steam pipe and in the cylinder during the admission.

To permit the ready escape of the steam during the back stroke, the exhaust pipe should be of at least double the area of the steam pipe.

For the sake of simplicity, it is an almost universal practice to make the steam enter and leave a given end of the cylinder through the same port. Mr. Joule has pointed out that this practice tends to the waste of heat, especially with high rates of expansion; because the cool expanded steam, in escaping, cools the metal of the port, which is again heated at the expense of the heat of the next cylinderful of hot steam that enters; and all the heat so transferred from the entering to the escaping steam is wasted. Mr. Joule therefore recommends the use of *separate admission and exhaust ports*.

341. **Throttle Valve.**—When the throttle valve is controlled by a governor, it is usually a disc-and-pivot valve (as to which, see Article 119, page 123, and fig. 40, page 140, U, V); because that valve is easily moved.

A throttle valve to be controlled by hand may be a disc-and-pivot valve, or an ordinary slide valve moved by a screw (Article 120, page 124), or a rotating slide valve (Article 120, page 125), or a conical valve moved by a screw (Article 121, pages 125, 126). The last named form of throttle valve is now much used in locomotive engines, and will be illustrated in a subsequent Article.

342. **Conical and Double Beat Valves.**—In Watt's earlier engines, conical valves with vertical spindles (Article 112, page 118) were used to regulate the distribution of the steam. Now *double beat valves* (Article 116, pages 121, 122, figs. 33, 34) are used in all cases in which the slide valve is not employed.

In a single acting engine, there are three such valves, viz. :—

I. The *steam valve*, which opens at the beginning of the forward stroke to admit steam to drive the piston, and closes to *cut off* the steam at the proper instant.

II. The *equilibrium valve*, which is closed during the forward stroke, and open during the return stroke, the expanded steam being then transferred through it from the one end of the cylinder to the other.

III. The *eduction valve*, which is closed during the return stroke, and open during the forward stroke, to let the steam in front of the piston escape to the condenser.

In a double acting engine, there are four valves, one pair for each end of the cylinder, and each of these pairs consists of—

I. A *steam valve*, opening at the beginning of each forward stroke, and closing to cut off the steam at the proper instant.

II. An *eduction valve*, closed during the forward stroke, and open during the return stroke, to let the steam escape to the condenser.

343. Plug Rod and Tappets.—The motions of conical and double beat valves, in single acting engines, and in some double acting engines also, are produced by means of a "*plug rod*," which hangs vertically from the beam of the engine, near the cylinder, and rises and falls vertically along with the piston. From its sides, suitably formed pins and bars project, whose positions can be adjusted by screws; and these projecting pieces, striking levers at certain instants in the course of each stroke, produce the required motion of the valves.

In single acting engines, the exhaust valve and the steam valve are not opened directly by the action of the plug rod, but by a piece of mechanism called the "*cataract*," of the nature of a pump brake, already referred to in Article 50, page 58. It consists principally of a small loaded piston, moving in a vertical cylinder which contains water or oil. At the end of the forward stroke of the engine, a pin projecting from the plug rod lifts the cataract piston. That piston, on being set free, descends with a speed which is determined by the degree of opening of the regulating cock through which the liquid below it is discharged; and towards the end of its descent it acts successively upon two catches which liberate weights that in their descent open the exhaust valve and the steam valve. Thus, by varying the opening of the regulating cock of the cataract, the engine can be caused to make more or fewer strokes per minute.

The arrangement of the valve motions of single acting engines may be varied in its detail. One of its forms will be illustrated in a subsequent Article.

344. Slide Valves, on account of the simplicity of their action,

and smoothness of their motion, are almost universally employed in Europe for the distribution of the steam in double acting engines.

The *seat* of a steam engine slide valve consists usually of a very accurate plane surface, in which are oblong openings or *ports*. These are at least two in number; one communicating with each end of the cylinder. The seat of the short slide valve has a third, or *exhaust port*, between the first two, which is the passage for the escape of the exhaust steam. In some special forms of engine the ports are more numerous still.

The *long slide valve*, or *D-slide*, represented by *c* in fig. 130, and by figs. 131, 132, and 133, might also be classed as a sort of hollow



Fig. 131.

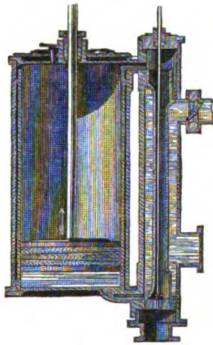

Fig. 132.

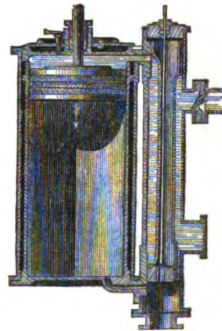

Fig. 133.

or tubular *piston valve*; for the back of the valve, which is semi-cylindrical, is made to move steam-tight at its top and bottom in the semi-cylindrical valve chest, by means of two half-rings of metallic packing.

Fig. 131 shows a vertical section of the valve, separate from the valve chest and cylinder. *c, c,* are the two portions of which its plane face consists: at its back near the top and bottom are seen sections of the packing half-rings. The valve rod is shown passing down through the tubular interior of the valve, and attached to a cross bar at the bottom. This bar is flat and thin, and placed with its breadth vertical, so as to contract as little as possible the passage through the interior of the valve. Figs. 132 and 133 are vertical sections of the cylinder, valve chest, and valve. The steam is admitted through the steam pipe and throttle valve to the middle part of the valve chest, which surrounds the tubular part of the valve. The two ends of the valve chest communicate with the condenser, the lower end directly, and the upper end through the interior of the tubular part of the valve.

In fig. 132, the valve is in its *highest* position: the middle part of the valve chest communicates with the *top* of the cylinder, admitting steam to drive the piston *downward*; the *bottom* of the cylinder communicates with the bottom of the valve chest, and so with the condenser.

In fig. 133, the valve is in its *lowest* position: the middle part of the valve chest communicates with the *bottom* of the cylinder, admitting steam to drive the piston *upward*: the *top* of the cylinder communicates with the top of the valve chest, and thence through the tubular interior of the valve, with the condenser.

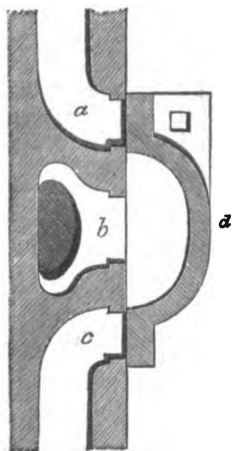

Fig. 134.

The *short slide valve* is represented in figs. 134, 135, 136, 137, and 138. Fig. 134 is a longitudinal section of the valve and its seat. The cylinder is supposed to be vertical: *d* is the slide valve; *a* the upper and *c* the lower cylinder port; *b* the exhaust port, leading sideways to the condenser, or to the air, according as the engine is condensing or non-condensing. Fig. 135 is a front view of the valve seat and ports; fig. 136, the face of the valve. The steam is admitted from the boiler into the valve chest, round and behind the valve. In fig. 134, the valve is in its middle position, and both the cylinder ports are closed. In fig. 138, the valve is depressed so far below its middle position as to open the upper port for the admission of steam above the piston; while at the

same time the lower port is connected through the interior of the valve with the exhaust port, so as to allow the steam from below the piston to escape as the piston descends. In fig. 137, the valve is raised so high above its middle position as to open the lower port for the admission of steam below the piston; while at the same time the upper port is connected through the interior of the valve with the exhaust port, so as to allow the steam from above the piston to escape as the piston rises.

The shortslide valve is pressed against its seat, and the joint between it and its seat kept steam-tight, by the excess of the pressure of the steam in the valve chest behind the valve, which comes from the boiler, above the pressure of the steam in the interior of the valve, which communicates with the condenser or with the atmosphere, as the case may be.

In large engines, the amount of that difference of pressure, over the whole area of the face of the valve, would be unnecessarily great,

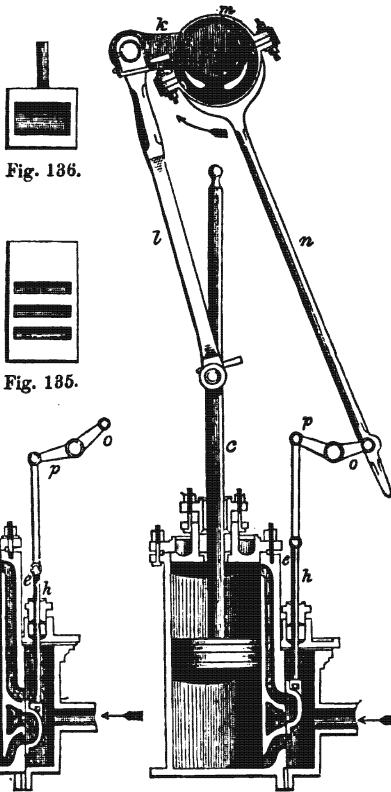

Fig. 136.

Fig. 135.

Fig. 138.

Fig. 137.

causing too much work to be lost in overcoming friction. To diminish its amount is the object of the contrivance called the *equilibrium slide valve*, in which the interior of the back of the valve chest is a true plane, parallel to that of the valve seat; and the back of the valve is provided with a flat brass packing-ring, which is pressed against the back of the valve chest by springs. The amount of the pressure of the valve against its seat due to the pressure of the steam from behind, is the product of the intensity of that pressure into the excess of the area of the face of

the valve above the area of the packing-ring at its back, and may be reduced to any required amount, how small soever, by making that ring large enough.

345. **Eccentric.**—It is obvious that to produce the proper distribution of the steam by a slide valve, whether long or short, the valve must have a reciprocating motion of such a nature as to bring it to the ends of its stroke, being its greatest distances from its middle position, at periods intermediate between those at which the piston reaches the ends of its stroke. The eccentric e (fig. 139), which is used to give that motion, is a circular disc carried by the shaft, with whose axis the centre of the disc does not

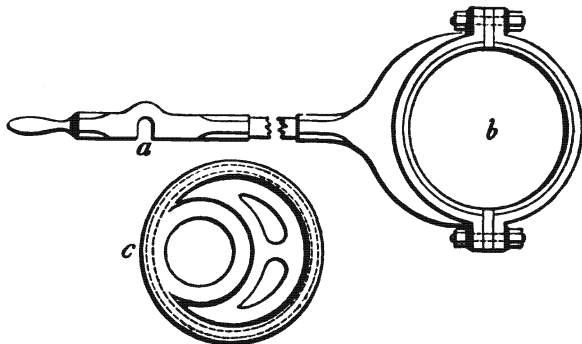

Fig. 139.

coincide. It is equivalent to a crank whose length is equal to the *eccentric radius*; that is, the line joining the centre of the disc and the axis of the shaft; and being encircled with a hoop, b , at one end of the *eccentric rod*, a , it gives to that rod a reciprocating motion whose length of stroke is the double of the eccentric radius. The eccentric rod is either directly jointed to the slide valve rod, or connected with it by any convenient combination of levers and link-work. One such arrangement is shown in figs. 137 and 138, of Article 394, where c is the piston rod; l , the connecting rod; k , the crank; m , the eccentric; n , the eccentric rod; o , p , levers; $p e$, a link; h , the slide valve rod.

The notch opposite the letter a , in fig. 139, is the *gab* of the eccentric rod, by which it holds a pin on the end of the lever that is directly driven by it (as o , figs. 137, 138). By means of a handle on the end of the eccentric rod, the gab and pin can be disengaged and re-engaged, so as to throw the valve motion "*out of gearing*" and "*into gearing*," and thus make the slide valve stop and resume its motion when required.

In many engines a different contrivance is used, called the "*link motion*," to be afterwards described.

346. **Reversing by the Loose Eccentric.**—To reverse the direction of rotation of the shaft of a steam engine, the piston must be made to come to rest and then to move the reverse way, before completing a stroke, and the eccentric must assume that position relatively to the crank which is proper for working the slide valve when the rotation of the shaft is reversed. That position (or the position of *backward gear*) is somewhat less than half a circumference from the position of *forward gear*, measured round the shaft *in the direction of forward rotation*. To bring the eccentric, therefore, into backward gear, it is sufficient to cause it first to stand still while the shaft nearly finishes the first half-turn backwards, and then to accompany the shaft in its rotation.

In most stationary engines, and many marine engines, those objects are effected by having the eccentric loose on the shaft, and so counterpoised, that its centre of gravity shall be in the axis of the shaft; but prevented from turning completely round by means of two shoulders, one of which holds it in the position of forward gear, and the other in that of backward gear; care being taken that the motion of the loose eccentric round the shaft shall be *forwards* to go from forward into backward gear, and *backwards* to go from backward into forward gear.

To reverse an engine with a loose eccentric, the gab is to be disengaged from its pin and the slide valve shifted by hand if necessary. When the shaft has made part of a turn backwards the gab is to be re-engaged.

For example, in fig. 137, the piston is rising, and the shaft turning toward the right. To reverse that rotation the gab is disengaged, and the slide valve shifted into the position shown in fig. 138; so that steam from the boiler being admitted to press on the top of the piston, brings it to rest before it has completed its up stroke, and then drives it downwards, so as to make the shaft rotate towards the left. During the left-handed rotation the eccentric stands still until it is in the position of backward gear: then the gab is re-engaged with its pin, the slide valve resumes its motion, and the left-handed rotation goes on till the engine is stopped, or reversed again by the same process.

According to a mode of reversing by the loose eccentric, used by Messrs. Randolph, Elder, & Co., the eccentric, instead of standing still till the engine has turned back, is made by a combination of wheelwork, to *overtake* or *outrun* the shaft while the engine is moving forward, until it reaches the position of reverse gearing; and the reversal of the motion of the engine follows.

347. **Lead and Lap—Expansion by the Slide Valve.**—A slide

valve is said to have *lead*, when it has passed beyond the middle of its stroke or throw at the instant when the piston arrives at either end of its stroke. When the slide valve is at its middle position exactly at the instant of the arrival of the piston at either end of its stroke, it is said to have *no lead*.

The amount of the lead may be measured and expressed in three ways, viz:—

I. In absolute measure, such as inches.

II. By the *proportion* of the absolute lead to the half-throw of the slide valve. This may be called the *ratio of lead*.

III. By the angle at which the eccentric radius stands in advance of the position which it would require to have relatively to the crank, in order to make the middle position of the side valve occur at the same instant with the end of the piston stroke. This may be called the *angle of lead*.

When a loose eccentric has no lead, its positions of forward and backward gear are half a circumference apart. When it has lead, the angle between those positions is half a circumference less twice the angle of lead.

If the eccentric rod is so long relatively to the eccentric radius, that the effect of its varying obliquities on the positions of the points it connects may be neglected in practice, the following equation is sensibly accurate:—

$$\text{Ratio of lead} = \text{sine of angle of lead}; \dots\dots\dots(1.)$$

and in other cases the same equation always gives at least an approximation to the truth.

The angle of lead may be stated either in degrees, or as a fraction of a revolution.

The *lap*, or *cover*, of a slide valve at one of its edges is the extent to which that edge overlaps the adjoining edge of the port which it covers when the slide valve is in its middle position. In fig. 134 of Article 344, the slide valve has a very small and nearly equal extent of lap at each of its four edges.

Fig. 140 is a section of the lower half of a vertical slide valve and its port having a greater extent of lap; W is the lower port of a cylinder; X, the lower half of the slide valve, in its middle position; U is the *induction side*, and V the *eduction side* of the port; C is the *induction edge*, and P the *eduction edge* of the valve; UC is the *lap on the induction side*, and \overline{VP} the *lap on the eduction side*.

The upper port and the upper half of the valve need not be shown nor specially considered for the present; being similar

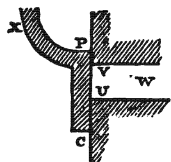

Fig. 140.

in figure to the lower port and lower half of the valve, but inverted.

The lap, like the lead, may be expressed in three ways, viz:—

I. In absolute measure, as inches.

II. By its proportion to the *half-throw* of the slide valve, which may be called the *ratio of lap*.

III. By the angle through which the eccentric must turn, in order to shift the valve from its middle position until the edge of the valve whose lap is considered touches the edge of the port—this may be called the *angle of lap*.

When the obliquity of the eccentric rod may be neglected, we have, sensibly,

$$\text{ratio of lap} = \text{sine of angle of lap} \dots \dots \dots (2.)$$

The use of the lead and lap of the slide valve is to admit the steam, cut off the admission, and cut off the exhaust, at given instants of the stroke of the piston, and so to produce expansive working with a given ratio of expansion, and to compress or cushion a given proportion of the expanded steam at the end of the return stroke.

When the obliquity of the connecting rod, as well as that of the eccentric rod, may be neglected, the following are methods by which the proper lead and lap of the slide valve in any case may be determined:—

FIRST METHOD:—By graphic construction. About a centre O describe a circle D E F I, and draw two diameters at right angles to each other, D F, E I. Consider D F as representing the stroke of the piston; and E I (though on a different scale), the throw of the slide valve; and let motion of the piston from D to F be considered as a forward stroke.

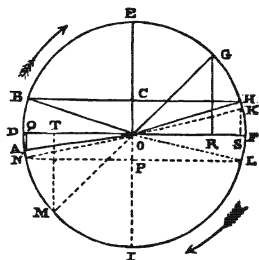

Fig. 411.

It is sometimes considered desirable to begin the admission of steam a little before the end of the return stroke. If so, let Q represent the point of the return stroke where the admission is to begin. If the admission and the forward stroke are to begin together, Q will coincide with D.

Let R be the point of the forward stroke where the steam is to be cut off.

Let T be the point of the return stroke where compression or cushioning is to begin, by cutting off the exhaust. As to the prin-

ciples which determine that point, see Article 291, Division III., page 420. These being the data, the solution consists of two parts, as follows:—

I. *To find the angle of lead, and the lap on the induction side:—* Draw $Q A$, $R G$, perpendicular to $D F$, cutting the circle in A , G ; measure or bisect the arc $A G$; from E lay off the equal arcs $E B$, $E H$, each = $\frac{\text{arc } A G}{2}$; join $B H$, which will be parallel to $D F$.

Then

$$\text{The angle of lead} = \angle A O B = \angle G O H; \dots\dots\dots(3.)$$

$$\frac{\text{Lap on the induction side}}{\text{half-throw}} = \frac{\overline{O C}}{\overline{O E}} \dots\dots\dots(4.)$$

II. *To find the lap on the eduction side and the point of release:—* Draw $T M$ perpendicular to $D F$, cutting the circle in M , from which lay off the arc $M N = \text{arc } A B$. Draw $N L$ parallel to $D F$, cutting $O I$ in P ; then

$$\frac{\text{Lap on the eduction side}}{\text{half-throw}} = \frac{\overline{O P}}{\overline{O E}} \dots\dots\dots(5.)$$

from L lay off the arc $L K = \text{arc } A B$, and from K let fall $K S$ perpendicular to $D F$; then will S represent the *point of release* during the forward stroke of the piston, where the valve begins to open on the eduction side. As to the effect of release, see Article 291, Division IV., page 421.

SECOND METHOD:—By trigonometrical calculation.

$$\text{DATA:—} \quad \frac{\text{Advance of admission}}{\text{Stroke of piston}} = \frac{\overline{D Q}}{\overline{D F}} = \frac{1}{q};$$

$$\text{Ratio of actual cut-off} = \frac{\overline{D R}}{\overline{D F}} = \frac{1}{r};$$

$$\text{Ratio of cushioning} = \frac{\overline{D T}}{\overline{D F}} = \frac{1}{r^n}$$

Half-throw of slide valve, $\overline{O E}$.

RESULTS:—

Let angle of lead = a ;

angle of lap on induction side, = b' ;

angle of lap on eduction side, = b'' ; then

$$\left. \begin{aligned} a - b' &= \cos^{-1} \left(1 - \frac{2}{q} \right); & a + b' &= \cos^{-1} \left(\frac{2}{r} - 1 \right); \\ a + b'' &= \cos^{-1} \left(1 - \frac{2}{r''} \right); \end{aligned} \right\} (6.)$$

in computing which three arcs, it is to be remembered that a *negative cosine* corresponds to an *obtuse angle*. This being done, we have—

$$a = \frac{(a + b') + (a - b')}{2}; \quad b' = \frac{(a + b') - (a - b')}{2}; \quad b'' = (a + b'') - a; \quad (7.)$$

and also,

$$\left. \begin{aligned} \text{lap on induction side, } \overline{OC} &= \overline{OE} \cdot \sin b'; \\ \text{lap on eduction side, } \overline{OP} &= \overline{OE} \cdot \sin b''; \end{aligned} \right\} \dots\dots\dots(8.)$$

Fraction of stroke at which release occurs,

$$\frac{\overline{DS}}{\overline{DF}} = \frac{1 + \cos(a - b'')}{2} \dots\dots\dots(9.)$$

When it is necessary to take into account the obliquity of the connecting rod and of the eccentric rod, use one or other of the foregoing approximate methods to find the *angle of lead*. Then make an accurate skeleton drawing, on a sufficiently large scale, showing, in the first place, the crank in a series of equidistant angular positions. The lead being known, will enable the corresponding positions of the eccentric radius to be laid down. Draw the centre line of the piston rod, and that of the slide valve rod, upon which, by means of the known lengths of the connecting rod, eccentric rod, and other intermediate pieces of the mechanism, lay down the positions of the piston, and of the slide valve corresponding to the given series of positions of the crank and eccentric. The number of positions employed is usually from twelve to twenty-four, and they are numbered on the drawing in their order of succession.

Then draw to the same scale a diagram in the following manner (fig. 142):—Draw a pair of rectangular axes \overline{DF} , \overline{EI} , bisecting each other in O . Make $\overline{OD} = \overline{OF}$ = the half stroke of the piston, and $\overline{OE} = \overline{OI}$ = the half-throw of the slide valve. On \overline{DF} , which represents the stroke of the piston, mark points corresponding to the series of successive positions of the piston found by means of the

skeleton drawing; and from those points lay off ordinates parallel to $E I$, upwards or downwards as the case may be (such as $A Q$,

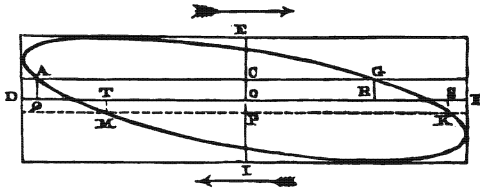

Fig. 142.

$T M$, &c.), representing the corresponding successive distances of the slide valve from its middle position, as shown by the skeleton drawing. Through the ends of these ordinates sketch a curve $M A G K$, which will be an oval, approaching more or less nearly to an elliptic figure, inscribed in the rectangle whose axes are $D F$, $E I$.

Then mark the required points of cut-off R , and commencement of cushioning T ; draw the ordinates $R G$, $T M$, perpendicular to $D F$, cutting the oval in G , M . Then

$$\left. \begin{aligned} \text{The required lap on the induction side} &= \overline{R G}; \\ \text{,, ,, eduction side} &= \overline{T M}. \end{aligned} \right\} \dots(10)$$

Further, draw $G A$ and $M K$ parallel to $D F$, cutting the oval in A and K , from which points let fall on $D F$ the perpendiculars $A Q$, $K S$. Then will Q be the point of the stroke at which the admission begins, and S the point of release.

Numerous examples of this process are given in Mr. D. K. Clark's work on Railway Machinery.

Sometimes in the vertical cylinders of marine engines, the lap of the slide valve on the induction side is made less for the lower than for the upper port. The effect of this is to cut off the steam later, and to have a less ratio of expansion, and a greater mean effective pressure, during the up stroke than during the down stroke. The object is to equalize the energy exerted on the crank during the up and down strokes; and to attain that object perfectly, the difference of the mean effective pressures, multiplied by the area of the piston, should be equal to twice the weight of the piston, piston rod, and connecting rod, which weight assists the down stroke, and opposes the up stroke.

348. The **Link Motion**, which was first used in the locomotive engines of Mr. Robert Stephenson, is an arrangement of slide valve gear for reversing engines, and varying the rate of expansion at

will. Its general arrangement is represented in the sketch, fig. 143. In subsequent figures it will be shown in its place in locomotive and marine engines.

F' is the *forward eccentric*, and F the *backward eccentric*, being a pair of eccentrics fixed on the shaft in the position suitable for working the slide valve during forward and backward motion of the engine respectively. The angle between the two eccentric radii is the

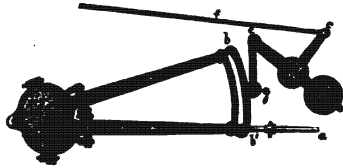

Fig. 143

supplement of twice the angle of lead. G' is the forward eccentric rod; G the backward eccentric rod. The ends of those rods are jointed to the two ends of a piece $b b'$, called the *link*, containing a slot, in which a stud or slider, on the end of the slide valve rod a , is capable of shifting into different positions; $e g$ is a rod by which the link hangs. In some cases the centre e is fixed, and the valve rod is jointed, so that the slider on its end can be moved to different positions in the link; and then the figure of the link is an arc of a circle, whose radius is the length of the shifting portion of the valve rod. In other cases (of which the figure is an example), the centre e is capable of being shifted, so as to move the link into different positions while the valve rod is at rest laterally; and then the figure of the link is an arc of a circle whose radius is equal to the effective length of each eccentric rod. In Mr. Allan's form of the link motion, half of the shifting is produced by moving the link in one direction, and the other half by moving the stud of the valve rod in the opposite direction; and in that form the link is straight. The link motion is very much varied in its details by different locomotive and marine engineers.

In the figure, the link hangs by the rod $e g$ from one arm of the lever $e d n$, balanced by a counterpoise on the opposite arm. $d c$ is a transverse arm, connected by a rod $c f$ with the *reversing handle* of the engine.

In the figure, the motion of the slide valve is produced by the action of the forward eccentric alone, and the engine is said to be in *full forward gear*. The steam is cut off at a point depending on the lap, the lead of the forward eccentric, and a throw equal to twice the eccentric radius.

When the link is shifted so that the stud of the valve rod is at the opposite end b of the link, the motion of the valve is produced by the action of the backward eccentric alone, and the engine is said to be in *full backward gear*. The steam is cut off at a point depending on the lap, lead, and throw, as before.

For any intermediate relative position of the link and stud, the motion of the slide valve is produced by the joint action of the forward and backward eccentrics, according to a law which may be approximately represented as follows:—at any given instant, let v' be the velocity which the valve would receive if in full forward gearing, v'' the velocity which it would receive if in full backward gearing; and let velocities in contrary directions be distinguished as positive and negative; also let l' be the distance of the stud from the forward end, and l'' its distance from the backward end of the link; then the actual velocity of the valve at the given instant is

$$v = \frac{l'' v' + l' v''}{l'' + l'} \dots \dots \dots (1.)$$

To find *exactly* the motions of the slide valve produced by different relative positions of the link and stud, a skeleton drawing of the mechanism is to be made on a sufficiently large scale, as in the process described in the last Article. For examples of this process also, Mr. Clark's work on Railway Machinery may be referred to.

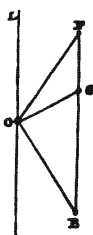

Fig. 144.

A useful *approximation* to the motions of the valve when the stud is in any given position relatively to the link, is as follows:—Let O represent the centre of the shaft, \overline{OF} the forward eccentric radius, \overline{OB} the backward eccentric radius; and let LO be a straight line parallel to FB. In full forward gearing, the *half-throw* is \overline{OF} , and the *angle of lead* $\angle LOF$; and on these and the lap the distribution of the steam depends. When the stud is at any intermediate position on the link, join FB, in which take the point S, dividing that line in the same proportion in which the stud divides

the length of the link; then the motion of the valve will be *nearly* that corresponding to an eccentric radius \overline{OS} ; so that the distribution of the steam will be *nearly* that corresponding to the constant lap, with the *diminished half-throw* \overline{OS} , and the *increased angle of lead* $\angle LOS$.

In *mid gear*, when the stud is midway between the ends of the link, the lead is 90° , and the half-throw is nearly $= \overline{OF} \times \sin \angle LOF$, being the perpendicular distance from O to FB.

It is evident, that the nearer the link motion is brought to mid gear, the earlier in the stroke is the steam cut off.

349. **Expansion Valve with Cams.**—A separate expansion valve is often used, especially in large marine engines, consisting of a double beat valve (Article 116, page 121), whose spindle is hung

from one arm of a lever. Another arm of the lever has a roller at its end, upon which a suitably shaped cam, turning with the engine shaft, acts so as to lift the valve twice in each revolution, hold it open during the proper period for the admission of the steam, and then let it close. A series of such cams, suited to produce different rates of expansion, are fixed side by side on the shaft, and the lever arm which carries the roller is so made that it can be shifted sideways, and brought into gearing with that cam which produces the proper rate of expansion. In some cases the rate of expansion is adjusted by a single cam, shifting endways along a screw-shaped part of the shaft under the action of the governor.

350. **Expansion Slide Valve.**—A separate slide valve is sometimes used to cut off the steam at an early period of the stroke, worked by an eccentric *without lead*, so that this expansion slide valve is always at its middle position when the piston is at either end of its stroke. A longitudinal section of part of such a valve is shown in fig. 145. A, A, are oblong ports in the plate which forms the valve seat, and which is usually the back of the valve chest of the ordinary slide valve. B, B, are oblong ports of the same size and figure with A A, in the sliding plate which forms the valve. The valve might



Fig. 145.

be made with only a single opening B, corresponding to a single port A; but to give ample area for the passage of the steam, there are usually several such openings and ports; whence the valve is called a “*gridiron valve*.” When the valve is in its middle position (and the piston at one end of its stroke), the openings B are exactly opposite to the ports A, which are then “*full open*.” So soon as the valve has moved in either direction to a distance from its middle position equal to the breadth of one of its openings, the ports are all closed, and the steam cut off.

This valve is suited for cutting off the steam at a very early period of the stroke only. The point of cut-off being given, the following are the processes for finding the requisite *proportion of breadth of openings to half-throw*.

FIRST METHOD:—By graphic construction (fig. 146). About a centre O, describe a quadrant of a circle D E, and draw a radius O D, to represent the *half stroke of the piston*, in which take the point R to represent the point of the stroke at which the steam is to be cut off. From R draw R G perpendicular to D O, cutting the circle in G. Then

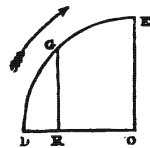

Fig. 146.

$$\frac{\text{Breadth of openings}}{\text{Half-throw of valve}} = \frac{\overline{R G}}{\overline{O E}} \dots \dots \dots (1.)$$

SECOND METHOD:—By calculation. Let ratio of actual cut-off $\frac{DR}{2OD} = \frac{1}{r'}$; then

$$\frac{\text{Breadth of openings}}{\text{Half-throw of valve}} = \sqrt{\left\{1 - \left(1 - \frac{2}{r'}\right)^2\right\}} \dots\dots(2.)$$

A peculiarity of this valve is that it *reopens* its ports at a point of the piston stroke as far distant from the end as R is from the beginning; therefore it cannot be used except in combination with a common slide valve, so adjusted as to cut off the steam before the reopening of the ports of the gridiron expansion valve. For example, if the expansion valve cuts off at 0·2 of the stroke, the common slide valve must cut off at or before 0·8 of the stroke.

The rate of expansion may be varied by varying the throw of the expansion valve. In some engines, the seat of the expansion slide valve is formed by the back of the ordinary slide valve, which, instead of admitting the steam past its outer edges, has *ports* through it like the openings in a gridiron valve, and the expansion slide valve is worked by an independent eccentric, so as to close those ports at the proper instants.

The "gridiron" form is sometimes adapted to the ordinary slide valve in very large engines—that is to say, each end of the cylinder has two parallel ports, and the valve is formed so as to connect the two ports belonging to one end of the cylinder at the same time, with the valve chest and the eduction port alternately.

351. Double Beat Valves Worked by Eccentrics.—In the engines of American steamers double beat valves are extensively used, driven by means of eccentrics. There are usually separate eccentrics for the induction and eduction valves. Each eccentric, through a rod and lever, causes a rocking shaft to vibrate to and fro; the rocking shaft carries cams, which, by acting on bars and levers, lift and lower the valves at the proper times. Each cam is so shaped as to give a very gentle motion to the valve when it is nearly in contact with its seat, and a rapid motion during other parts of its stroke, so that the port is opened and closed quickly, and at the same time without shock.

SECTION 3.—Of *Cylinders and Pistons.*

352. Common Cylinders.—Cylinders are made of the toughest cast iron that can be obtained. The thickness required for the sake of mere tenacity, to resist the internal pressure, might be calculated from the principles stated in Article 62, pages 67, 68, allowing *six* as a factor of safety; but in order that the cylinder may possess

that stiffness which is necessary to enable it to preserve its figure with great accuracy, it must be made many times thicker than is necessary for mere strength. The actual factors of safety of the cylinders of steam engines, as they occur in practice, range from 30 to 40.

The bottom of a cylinder is sometimes cast in one piece with it, sometimes bolted on. The cylinder cover is bolted on. Care must be taken that the bolts have sufficient strength to withstand the pressure. The bottoms and covers of large cylinders are often made of the form of a segment of a sphere of large radius—in which case the two sides of the piston are made of the same figure, in order that space may not be lost in clearance.

The effect of the jacket has already been fully considered. The jacket ought to envelop not merely the body of the cylinder, but at least one end also, and, if possible, both ends. Whether the cylinder is jacketed or not, it should always be clothed (Article 387, Division IX.)

353. In **Double Cylinder Engines**, the attempt should be made so to proportion the cylinders to each other, that the steam shall perform half its work in the small cylinder and half in the large. In most actual engines two-thirds of the work are performed in the small cylinder. The following are some of the arrangements of double cylinder engines:—

I. The earliest arrangement of double cylinders was Woolf's, in which the smaller or high pressure cylinder, and the larger or low pressure cylinder stand side by side under the same end of a beam, and their pistons move in the same direction at the same time. In this arrangement the steam passes from either end of the small cylinder to the opposite end of the large cylinder.

II. In Mr. M'Naught's engine the cylinders are under opposite ends of a beam, their pistons move opposite ways, and the steam passes from either end of the small cylinder to the nearest end of the large cylinder.

III. In Mr. Elder's marine engine the large and small cylinders lie side by side in close contact, sloping at an angle of 45° ; their pistons move opposite ways at the same time, and drive cranks which project in opposite directions from the shaft, with a view to the reduction of the pressures on the bearings of the shaft, and the consequent friction, to the smallest amount possible with two cylinders. A similar pair of cylinders, sloping the opposite way at the same angle, act on the same pair of cranks.

IV. In Mr. Craddock's engine the large and small cylinders are side by side, and their pistons move for the greater part of their course in opposite directions, and drive a pair of *nearly opposite* cranks. In order to facilitate the passing of the dead points with

only one pair of cylinders, the stroke of the small cylinder is made somewhat *in advance* of that of the large cylinder; the effect of which is that the steam, after having been expanded until it fills the small cylinder, is not immediately admitted into the large cylinder, but is first re-compressed to a certain extent in the small cylinder, and then admitted into the large cylinder to expand. The ultimate expansion is exactly the same as if the strokes of the cylinders were simultaneous, and so also is the efficiency, provided no waste of heat by conduction takes place during the temporary compression of the steam. Mr. Craddock proposes to carry the advance of the stroke of the small piston, in some cases, as far as a quarter of a revolution; but it appears from experiment that a less angle of advance, such as one-sixth or one-twelfth of a revolution, is sufficient to enable the dead points to be easily passed; and it is not desirable to carry the advance beyond what is necessary for that purpose, because of the derangement which it produces in the action of the steam when the motion of the engine is reversed.

354. **The Concentric or Duplex Cylinder** of Mr. David Rowan, consists of a smaller cylinder, into which the steam is first admitted and begins its expansion, contained within and concentric with a large cylinder, in which the expansion is continued, and is equivalent to the two cylinders of a double cylinder engine. The inner piston is of the common shape; the outer is ring-shaped, and has packing not only on its outer surface, but also on its inner surface, which slides on the outside of the inner cylinder. The one piston rod of the inner piston, and the two piston rods of the outer piston are fixed to one cross-head, so that the two pistons move together, and the steam has to pass from either end of the inner cylinder to the opposite end of the outer cylinder. The steam is superheated sufficiently to prevent condensation to an injurious extent in either cylinder.

355. **Treble Cylinder Engines** differ from double cylinder engines merely in having a pair of large cylinders for the continuation of the expansion, one at each side of the small cylinder, instead of one large cylinder.

In Mr. Elder's treble cylinder engine the piston of the central small cylinder drives one crank, and those of the two lateral large cylinders drive a pair of cranks pointing the opposite way to the middle crank. If half the work is performed in the middle cylinder, and the other half divided equally between the lateral cylinders, there is an exact balance of pressures on the shaft, and the friction of its bearings is simply that due to the weight resting on them.

In Mr. J. M. Rowan's treble cylinder engine the rods of the small middle piston, and of the two large lateral pistons, are all attached to one cross-head, so that the three pistons move together. The

arrangement is compact, and convenient for oscillating engines, to which it is applied.

356. End to End Double Cylinder Engine.—In this engine (Mr. Sim's) the steam begins its action in one end of a small cylinder, and completes it in the opposite end of a large cylinder; the two cylinders are placed end to end, and their pistons are attached to one rod. The space between the two pistons communicates with the condenser, and is a partial vacuum at all times.

357. Double Piston Engine.—In this engine (Mr. Carrett's) the steam is first admitted to and begins its expansion in one end of a cylinder, and finishes its expansion in the opposite end. The former end has its capacity diminished, so as to be equivalent to a small cylinder, by means of a plunger of sufficiently large diameter, having one end fixed to the piston, and passing through a packing-ring in the cover. The other end of the same plunger acts as plunger of the air pump.

358. An Oscillating Cylinder is mounted on *gudgeons* or *trunnions*, generally near the middle of its length, on which it is capable of swaying to and fro through a small arc, so as to enable the piston rod to follow the movements of the crank, to which it is directly attached without the intervention of a connecting rod. This construction is very advantageous in point of economy of space and weight.

The trunnions are hollow, and are connected by steam-tight joints, one with a steam pipe leading from the boiler—the other with an exhaust pipe leading to the condenser. The valve chest oscillates with the cylinder. Various arrangements are used to adapt the valve gearing to the oscillating motion of the cylinder and valve chest; one of the simplest being to communicate motion from the eccentric to a sliding rod on which is a cross-head of the form of an arc of a circle described about the axis of the trunnions when the valve is in its middle position, and having in it a slot of the same figure; in that slot is a slider attached to the end of a lever arm projecting from a rocking shaft carried by the cylinder; another arm projecting from that shaft moves the slide valve rod.

359. Sector Cylinders.—In some American steamers the place of an ordinary cylinder is supplied by a sector of a cylinder, in which a rectangular piston oscillates to and fro like a door on its hinge. In the position of the hinge is a rocking shaft, to which the piston is fixed; and by means of an arm projecting from one of the outer ends of that shaft and a connecting rod, motion is communicated to the crank.

360. In Rotatory Engines the place of an ordinary cylinder is supplied by a vessel of the shape of a cylinder, a zone of a sphere, or some other solid of revolution, traversed along the direction of its

axis by a shaft, which carries a revolving piston of a suitable shape. A partition divides the space between the piston and the cylinder into two parts; that partition is so constructed as not to obstruct the motion of the piston; in general the partition moves aside to let the piston pass. The steam is admitted into the space behind the piston, cut off periodically if required, and discharged from the space in front of the piston; and so the piston is driven continuously round. The number of rotatory engines which have been patented in Britain alone is certainly upwards of two hundred, and perhaps considerably more; but very few have been brought into practical operation, and those to a limited extent only; for their friction and liability to wear have been found to be greater than those of ordinary engines, and they have no advantage except compactness. The most successful appear to have been the Earl of Dundonald's, and Mr. David Napier's.

361. **Disc Engine.**—This engine, the invention of Mr. Bishop, has been used with success by Messrs. Rennie & Son to drive screw propellers. Fig. 147 is a sketch showing its general nature only,

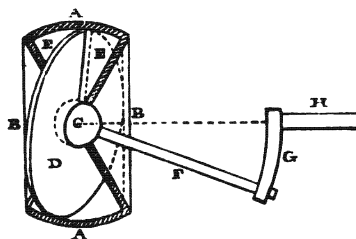

Fig. 147.

without any details. The cylinder is shown in section, the piston in elevation. The cylinder, or vessel which acts as a cylinder, is bounded laterally by a spherical zone A A, and endwise by a pair of cones, B, B, whose apices coincide with the centre C of the sphere. The piston is a flat circular disc, D, fitting the interior of the spherical zone round its edge.

EE is a fixed partition in the cylinder, shaped like a sector of a circle; a radial slit in the disc fits this partition. The disc is fixed to a ball, C, being the joint on which it turns; and from that ball projects a rod F, perpendicular to the plane of the disc. This rod acts in a manner as a crank pin; for its end fits into a round hole at the end of the crank G, which is carried by the shaft H, whose axis coincides in direction with the common axis of the spherical zone and of the two cones. By the disc D, and partition EE, the cylinder is divided at each instant into four spaces, two of which are enlarging while the other two are contracting, as the crank G revolves; the steam is admitted into the two former spaces, and discharged from the two latter spaces, by ports near the partition EE, and can be cut off if required by an expansion valve; thus the disc is made to take a sort of motion of *nutation*, and the crank shaft is driven round. The angle H C F between the shaft and

crank pin is one-half of the angle between the sides of the two cones B, B.

Let the angle H C F = θ . Let r be the internal radius of the spherical zone, r' that of the ball C. Then the volume swept through by the disc at each revolution is

$$8.3776 (r^3 - r'^3) \sin \theta; \dots\dots\dots(1.)$$

being equal to twice the capacity of the vessel which acts as a cylinder, and being also the product of the area of the disc, $3.1416 (r^2 - r'^2)$, and the mean distance swept through by all parts of its surface in directions perpendicular to themselves during each revolution, $\frac{8}{3} \cdot \frac{r^3 - r'^3}{r^2 - r'^2} \cdot \sin \theta$.

The volume given by the formula 1 corresponds to that which, in computing the power of common double acting steam engines, is found by multiplying the area of the piston into twice the length of a single stroke.

362. **Pistons and Packing.**—Ordinary pistons agree pretty nearly as to figure and proportions, with the description of a piston for a water pressure engine already given in Article 127, page 129; but instead of the hempen packing, metallic packing is universally used, made of brass, or of cast iron. Fig. 148 represents one of the most complex arrangements of metallic packing, with the junk ring (as it is still called) removed. There are two, or sometimes three, rings of packing, each consisting of an outer and inner circle of arcs of metal, built together so as to break joint, and pressed outwards against the interior of the cylinder by means of springs. Much simpler arrangements are often used, especially one in which there is only a single packing ring divided at one point, and pressing against the sides of the cylinder by its own elasticity, which, as it is originally made of a radius a little larger than that of the cylinder, causes it to tend to expand. The gap at the point of division is sometimes filled by a tongue piece morticed into the ends of the ring; sometimes by a small wedge-formed block, pressed outwards by a spring behind it. Mr. Ramsbottom's piston for locomotives has a cylindrical surface turned to fit the interior of the cylinder loosely; round that cylindrical surface are three parallel rectangular grooves, each filled by a single packing ring of *square* brass wire, measuring about an eighth of an inch each way; each of these rings is divided

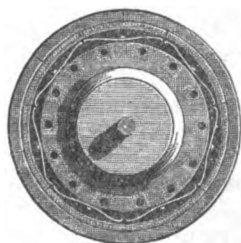

Fig. 148.

at one point, and presses outwards against the cylinder by its elasticity, like the single packing ring beforementioned. The points of division are placed at the lower side, where the body of the piston touches the cylinder. The varieties of metallic packing are very numerous; but they differ chiefly in points of detail.

Hemp is frequently used as an elastic material behind metallic packing, to keep it pressed against the cylinder.

Metallic rings, or pieces of sheet brass, packed behind with hemp, are used also for the packing of stuffing-boxes.

363. Piston Rods and Trunks.—In most engines, each piston has but one rod, fitted at one end into a conical socket in the centre of the piston, and fixed by means of a gib and cotter, or a screw and nut. The piston rod passes through a stuffing-box in the centre of the cylinder cover.

In some marine engines, two piston rods, and in some four, are attached to one piston, and traverse a corresponding number of stuffing-boxes in the cylinder cover. These arrangements form part of peculiar systems of mechanism for connecting the piston with the crank.

A *trunk* is a tubular piston rod, used to enable the connecting rod to be jointed directly to the piston, or to a very short inner piston rod, so as to save room in marine engines. The width of the trunk must be sufficient to give room for the lateral motion of the connecting rod.

As to the strength of piston rods, see Article 71, pages 73, 74. In computing the stress on a piston rod, the *greatest* pressure of the steam must be taken into account. The usual *factor of safety* is about 6 or 7; but in some cases it is as low as 5, and in others as high as 10.

364. Speed of Pistons.—The speed of the piston of an engine is usually expressed in *feet per minute*, the whole motion being taken into account in double acting engines, but the forward strokes only in single acting engines, as has already been explained.

An opinion at one time prevailed, that there was an advantage in making the real speed of pistons follow the rule laid down in Article 336, page 479, for calculating the fictitious speed assumed in computations of nominal horse-power; and although that opinion has been shown to be groundless, the ordinary speeds of the pistons of stationary engines and marine paddle engines do not often deviate much from those given by that rule, and range accordingly from about 120 to 300 feet per minute. But in marine screw engines, and in locomotive engines, speeds of piston are used ranging up to 900 feet per minute and more, with advantageous results. American engineers, by giving great length to the cylinder and crank, obtain a high speed of piston in paddle engines also.

Inasmuch as the work performed by the piston in an unit of time is the product of the effort into the speed, it follows that a high speed of piston involves a small stress upon the machinery, bearings, and framework, and consequently, a small amount of friction; circumstances favourable to lightness, and to economy of cost and of power.

The velocity of the piston being proportional to the length and frequency of the strokes jointly, there are two means of obtaining a high velocity: great length of stroke, and great frequency. Of those two means, great length of stroke is to be preferred, when there is no reason to the contrary; because great frequency of stroke, requiring rapid reversal of the motion of the piston, and the other masses which move along with it, produces periodical strains, by reason of the inertia of those masses, which to a certain extent neutralize the benefits arising from the smallness of the mean effort exerted through the piston rod.

The limit beyond which the velocity of the piston cannot with advantage be increased is not yet known. There must, however, be some such limit, because of the increase of the resistance to the motion of the steam through passages with increased velocity of its flow. (See Article 290, pages 413 to 417; Article 340, page 485.)

SECTION 4.—Of Condensers and Pumps.

365. **Watt's Condenser**, being that which is most generally employed, is a cast iron vessel of any convenient shape, and strong enough to bear the atmospheric pressure from without, in which the waste steam from the cylinder is condensed by a shower of cold water.

The *capacity* of the condenser in Watt's original engines was $\frac{1}{8}$ of that of the cylinder; but according to present practice, it ranges from $\frac{1}{4}$ to $\frac{1}{2}$, and sometimes even more.

The area of the *injection valve*, by which the condensation water is introduced into the condenser from the cold well in land engines, and from the sea in marine engines, is commonly fixed by one or other of the two following rules:—

$\frac{1}{16}$ square inch per cubic foot of water evaporated by the boiler per hour, or

$\frac{1}{16}$ of the area of the piston.

In Chapter III., Section 5, of this Part, formulæ have been given for computing the *net* quantity of injection water required to condense the steam in engines of various kinds, for each cubic foot swept through by the piston. The velocity with which the injection water flows towards the condenser *at the contracted vein* is about 44 feet per second. Taking 0.62 as the co-efficient of contraction,

the velocity of flow reduced to the area of the orifice itself is found to be 27 feet per second, or 1,620 feet per minute, nearly. To find, therefore, the proportion of the injection orifice to the area of piston, necessary in order to supply the *net* quantity of injection water, we have the following formula:—

$$\frac{\text{net area of orifice}}{\text{area of piston}} = \frac{\text{net volume of injection water per cubic foot swept through by piston} \times \text{velocity of piston in feet per minute} \div 1620}{\dots\dots\dots(1.)}$$

but it appears from ordinary practice, that to provide for contingences, the injection valve must be made capable of introducing, when required, about *double* the net quantity of injection water found by calculation; hence 810 is to be taken as the divisor in the above formula instead of 1,620. This gives results nearly agreeing with those of the practical rules first cited.

In marine engines, there is sometimes an injection valve leading from the ship's bilge into the condenser, which is opened only when the leakage of water into the ship threatens to become too great for the ordinary bilge pumps. On such occasions, the ordinary injection valve is closed.

366. The **Cold Water Pump**, by which in low pressure land engines the cold well is supplied with water, must be made of capacity sufficient to supply double the computed net injection water.

367. The **Air Pump** (Article 337, Division XVI., page 481), when single acting, is usually of a capacity from *one-fifth* to *one-sixth* of that of the cylinder; when the air pump is double acting, it may of course be made one-half smaller. The valves through which it draws the water, steam, and air from the condenser, are called *foot valves*; those through which it discharges those fluids into the *hot well*, *delivery valves*. A single acting air pump has *bucket valves* opening upwards in its piston. Flap valves, and other clacks of various forms, are used as air pump valves. As to the circular Indian rubber flap valves, now very generally employed, see Article 118, page 123. The ratio of the area of the valve passages to that of the air pump piston ranges in different engines from $\frac{1}{3}$ to equality, being made greater as the speed of that piston is greater, so that the velocity of fluids pumped may not in any case exceed about 10 or 12 feet per second.

The surplus water from the hot well, over and above that which is drawn away by the feed pumps (Article 316, page 164), is discharged by marine engines into the sea; and by land engines, if there is sufficient ground available, into a shallow pond, to be cooled and used again as condensation water.

368. **Surface Condensers** possess the advantages of preserving the purity of the water, by returning to the boiler the same water over and over again, without the admixture of condensation water from without (see Article 321, page 468), and of saving the power which is expended in pumping the condensation water out of the common condenser. Surface condensation appears to have been employed at an early period by Watt, but afterwards abandoned by him for condensation by injection, on account of practical difficulties. Various surface condensers have since been tried at different times with more or less success. Those of Mr. Samuel Hall were fitted up in several steamers.

A surface condenser consists generally of a great number of vertical tubes, about $\frac{1}{2}$ inch in diameter, united at their upper and lower ends by means of a pair of flat disc-shaped vessels, or of two sets of radiating tubes, or in some other convenient manner. This set of tubes is enclosed in a casing, through which a sufficient quantity of cold water is driven. The steam being led by the exhaust pipe to the upper end of the set of tubes is condensed as it descends through them, and arrives in the state of liquid water at the lower end of the apparatus, whence it is pumped away to feed the boiler.

Where condensation water is scarce or impure, it may be desirable to condense the steam by the contact of cold air with the outside of the tubes. To overcome the chief difficulty of this process, which consists in producing a sufficiently rapid circulation of air over the tubes, Mr. Craddock makes the whole apparatus of tubes rotate rapidly about a vertical axis.

Some results of experiment as to the efficiency of cooling surface in condensing steam have already been given in Article 222, page 266. The greatest of those results (that recently obtained by Mr. Joule) was the effect of casing each condensing tube in an outer tube, and driving a current of cold water through the annular space between the inner and outer tubes in a direction contrary to that of the motion of the condensing steam. To these data may be added the result of some recent experiments on a marine engine, in which the rate of surface condensation in half-inch brass tubes surrounded by water, estimated theoretically from the indicator diagrams, was between 3 and 4 lbs. per square foot of surface; the "vacuum" in the condenser being 13 lbs. on the square inch, and the absolute pressure, therefore, of uncondensed steam and air about 1.7 lb. on the square inch.

In a marine engine with a surface condenser, the loss of water by leakage, by blowing off at the safety valve, &c., is supplied by means of water distilled by suitable apparatus.

369. **Beam Engines and Direct Acting Engines.**—By *connecting mechanism* is meant the series of pieces through which motion is communicated from the piston rod to the piece, whether a rotating shaft or a reciprocating rod, by which the useful work is performed. With respect to connecting mechanism, steam engines may be divided into two great classes:—

I. *Beam Engines*, in which the piston rod is connected by means of a link, with one end of a *beam* or *lever* oscillating about a centre;

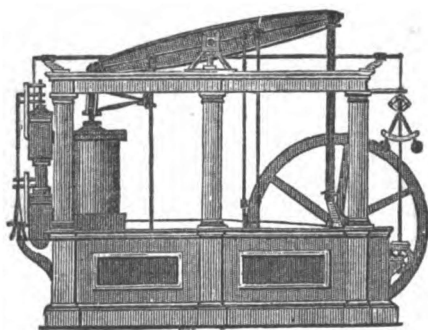

Fig. 149.

the other end of the beam being connected by a link or connecting rod with the pump rod or with the crank, according as the engine is non-rotative or rotative. The engine used as an illustration in Article 389, fig. 130, is a beam engine of the ordinary kind; but as the beam is there omitted, fig. 149 is added to show the general arrangement

of mechanism in such an engine.

II. *Direct acting engines*, in which the pump rod or the crank, as the case may be, is connected with the piston rod, either directly or by means of a connecting rod only. The engine used as an illustration in Article 344, fig. 137, is direct acting.

370. **Forces Acting on Beam and Cylinder.**—In a beam engine the velocities of the two ends of the beam at any given instant are to each other directly as the lengths of the two arms of the beam: the alternate pulls and thrusts exerted on the two ends of the beam by the piston rod and connecting rod, being inversely as the velocities of their points of application, are to each other inversely as the lengths of the arms of the beam.

The bearings of the “main centre,” or gudgeons of the beam, have to sustain, when the engine is at rest, the *weight* of the beam and the parts which hang from it: when the beam is in motion, the sum of the forces exerted by the piston rod and connecting rod is added to that weight during the down stroke of the piston, and subtracted from it during the up stroke.

The cylinder is pressed alternately downwards and upwards with a force equal and opposite to the effort of the steam on the piston;

and the strength of the fastenings of the cylinder to the framework must be regulated accordingly.

371. **Effort on Crank Pin—Fly-Wheel.**—The whole force exerted by the connecting rod on the crank pin may be resolved into two rectangular components, as in Article 23, page 31—a *lateral force* acting *along* the crank towards or from its axis of rotation, producing merely pressure on the bearings of the shaft, and an *effort*, acting perpendicular to the crank, in the direction of motion of the crank pin, by means of which effort the resistance of the machinery driven is overcome and work performed.

To find the ratio which that effort bears to the effort exerted by the steam on the piston, in any given position of the mechanism, it is sufficient to know the ratio of the velocity of the crank pin to that of the piston; for *the efforts are inversely as the velocities*.

The following are the methods by which that “velocity ratio” is found at any instant:—

CASE I. In a beam engine (fig. 150), let C_1 be the axis of motion of the beam; C_2 that of the crank shaft; $T_1 T_2$, the connecting rod, T_2 being the centre of the crank pin. At a given instant, let v_1 be the velocity of T_1 , which can be deduced from that of the piston, as in Article 370; v_2 that of T_2 .

To find the ratio of those velocities, produce $C_1 T_1$, $C_2 T_2$, till they intersect in K ; K is the “instantaneous axis” of the connecting rod, and the velocity ratio in question is

$$v_1 : v_2 :: \overline{KT_1} : \overline{KT_2} \dots \dots \dots (1.)$$

Should K be inconveniently far off, draw any triangle with its sides respectively parallel to $C_1 T_1$, $C_2 T_2$, and $T_1 T_2$; the ratio of the two

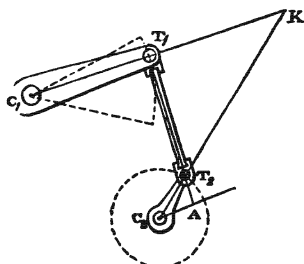

Fig. 150.

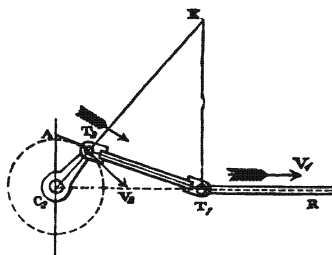

Fig. 151.

sides first mentioned will be the velocity ratio required. For example, draw $C_2 A$ parallel to $C_1 T_1$, cutting $T_1 T_2$ in A ; then

$$v_1 : v_2 :: \overline{C_2 A} : \overline{C_2 T_2} \dots \dots \dots (2.)$$

CASE II., in a direct acting engine (fig. 151.) Let C_2 be the axis of the crank shaft, and $T_1 R$ the piston rod; $C_2 T_2$ the crank; and $T_1 T_2$ the connecting rod. Draw $T_1 K$ perpendicular to $T_1 R$, intersecting $C_2 T_2$ produced in K ; K is the "instantaneous axis" of the connecting rod; and the rest of the solution is the same as in Case I., the formulæ 1, 2, giving the ratio of the velocity of the piston to that of the crank pin, which is also the ratio of the effort on the crank pin to the effort on the piston; that is to say—

$$C_2 T_2 : C_2 A :: \text{effort of steam on piston} : \text{effort of connecting rod on crank pin} \dots \dots \dots (3.)$$

It is by this process that data are obtained for determining the *periodical excess and deficiency of energy* exerted on the crank shaft, by the methods already explained in Article 52, pages 59, 60, 61, and thence, by the methods explained in Article 53, pages 61, 62, the required moment of inertia of a FLY-WHEEL which shall prevent the fluctuations of speed caused by that alternate excess and deficiency from going beyond given limits.

Marine and locomotive engines require no fly-wheels; for in the former the inertia of the propeller, whether paddle or screw, and in the latter that of the entire engine, suffice to prevent excessive fluctuations of speed.

372. Dead Points.—At two instants in each revolution, the direction of the crank coincides with the line of connection (or straight line joining the centres of the joints of the connecting rod). The positions of the crank pin at those instants are called *dead points*, and they correspond to the ends of the stroke of the piston, when its velocity vanishes, and so also does the effort on the crank pin. It is to diminish the irregular action caused by the existence of these dead points, and especially to facilitate the starting of engines when the crank happens to rest at one of them, that engines are combined by pairs or threes, as described in Articles 338 and 353, with the effect in diminishing the periodical excess and deficiency of energy stated in Article 52, page 60.

373. Guides for the Piston Rod are very accurately straight surfaces, plane or cylindrical, but best plane, on which a block fixed to the head of the piston rod slides, and which resist the tendency of the link, or of the connecting rod, when in an oblique position, to make the motion of the piston rod deviate from a straight line. The accuracy with which smooth plane surfaces can now be made has caused guides to be more generally used than they were formerly.

374. Parallel Motions are jointed combinations of linkwork, designed to guide the motion of the piston rod either exactly or approximately in a straight line, in order to avoid the friction

which attends the use of straight guides. The first parallel motion is well known to have been an invention of Watt. Four kinds of parallel motion will now be described:—

I. An **Exact Parallel Motion**, believed to have been first proposed by Mr. Scott Russell, is represented in fig. 152. The same parts of the mechanism are marked with the same letters, and different successive positions are indicated by numerals affixed. The lever CT turns about the fixed centre C , and carries, jointed to its other end, the bar or link PTQ , in which $PT = TQ = CT$. The point Q is jointed to a slider which slides in guides along the straight line CQ ; and the point P moves in the straight line $P_1C P_3 \perp CQ$. A pair of the combinations here shown are used, one at each side of the cylinder; and the pair of bars PQ are jointed at their extremities P to the head of the piston rod.

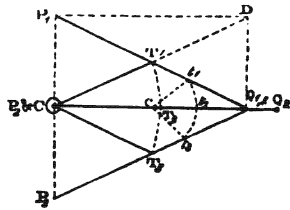

Fig. 152.

II. An **Approximate Parallel Motion**, somewhat resembling the preceding, is obtained by guiding the link PQ entirely by means of oscillating levers, instead of by a lever and a slide.

To find the length and the position of the axis of one of those levers, ct , select any convenient point, t , in the link PQ , and lay down on a drawing the extreme and middle positions, t_1, t_2, t_3 , of that point, corresponding to the extreme and middle positions of the link PQ .

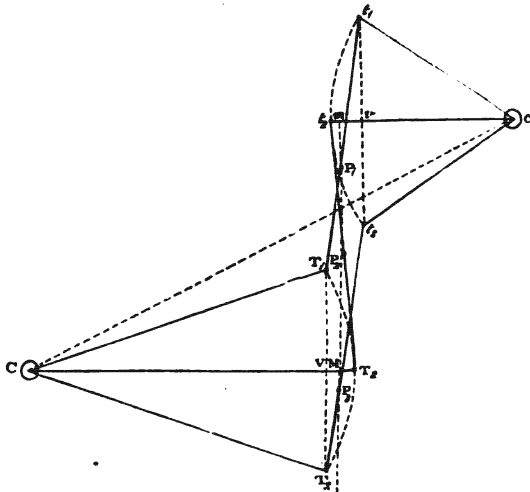

Fig. 153.

The centre c of a circle traversing those three points will be the required axis of the lever, and ct will be its length; and if the link PQ is guided by two such levers, the extreme and middle positions of P will be in one straight line,

and the other positions of that point very nearly in one straight line.

III. **Watt's Approximate Parallel Motion.**—In fig. 153, $C T, c t$, are a pair of levers, connected by a link $T t$, and oscillating about the axes C, c , between the positions marked 1 and 3. The middle positions of the levers, $C T_2, c t_2$, are parallel to each other. It is required to find a point P in the link $T t$, such, that its middle position P_2 , and its extreme positions P_1, P_3 , shall be in the same straight line perpendicular to $C T_2, c t_2$, and so to place the axes C, c , on the lines $C T_2, c t_2$, that the path of P , between the positions P_1, P_2, P_3 , shall be as near as possible to a straight line.

The axes C, c , are to be so placed, that the middle M of the versed sine $V T_2$, and the middle m of the versed sine $v t_2$, of the respective arcs whose equal chords $\overline{T_1 T_3} = \overline{t_1 t_3}$ represent the stroke, shall each be in the line of stroke $M m$.

The position of the point P on the link is found by the following proportional equation:—

$$\overline{T t} : \overline{P T} : \overline{P t} :: \overline{C M} + \overline{c m} : \overline{c m} : \overline{C M} \dots\dots\dots(1.)$$

The positions of the point P in the link, intermediate between its middle and extreme positions, are near enough to a straight line for practical purposes. When there are given, the axes C, c , the line of stroke $P_1 P_2 P_3$, the length of stroke $\overline{P_1 P_3} = S$, and the perpendicular distance $\overline{M m}$ between the middle positions of the two levers, the following equations serve to compute the lengths of the levers and link:—

$$\left. \begin{array}{l} \text{Versed sines,} \quad \overline{T V} = \frac{S^2}{8 \overline{C M}}; \quad \overline{t v} = \frac{S^2}{8 \overline{c m}}; \\ \text{Levers,} \quad \overline{C T} = \overline{C M} + \frac{\overline{T V}}{2}; \quad \overline{c t} = \overline{c m} + \frac{\overline{t v}}{2}; \\ \text{Link,} \quad \overline{T t} = \sqrt{\left\{ \overline{M m}^2 + \frac{(\overline{T V} + \overline{t v})^2}{4} \right\}}. \end{array} \right\} \dots\dots\dots(2.)$$

IV. **Watt's Parallel Motion Modified** by having the guided point P in the prolongation of the link $T t$ beyond its connected points, instead of between those points, is represented by fig. 154. In this case, the centres of the two levers are at the same side of the link, instead of at opposite sides, the shorter lever being the farther from the guided point P ; and the equations 1 and 2 are modified as follows:—

Segments of the link—

$$\overline{T t} : \overline{P T} : \overline{P t} :: \overline{C M} - \overline{c m} : \overline{c m} : \overline{C M} \dots\dots\dots(3.)$$

$$\left. \begin{array}{l}
 \text{Versed sines,} \quad \overline{T V} = \frac{S^2}{8 \overline{C M}}; \quad \overline{t v} = \frac{S^2}{8 \overline{c m}}; \\
 \text{Levers,} \quad \overline{C T} = \overline{C M} + \frac{\overline{T V}}{2}; \quad \overline{c t} = \overline{c m} + \frac{\overline{t v}}{2} \\
 \text{Link,} \quad \overline{T t} = \sqrt{\left\{ \overline{M m}^2 + \frac{(\overline{t v} - \overline{T V})^2}{4} \right\}}
 \end{array} \right\} \dots\dots(4.)$$

This parallel motion is used in some marine engines, in a position inverted with respect to that in the figure, P being the upper, and t the lower end of the link.

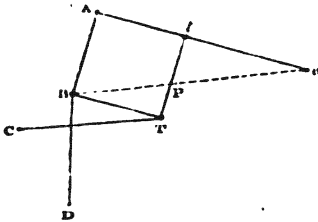

Fig. 155.

When Watt's parallel motion (III.) is applied to steam engines with beams, it is more usual to guide the air pump rod than the piston rod directly by means of the point P. The head of the piston rod is guided by being connected with that point by means of a *parallelogram* of bars, shown in fig. 154. c is the axis of motion of the beam of the engine, c t A one arm of that beam, C T a lever called the *radius bar* or *bridle rod*, T t a link called the *back link*. C T, c t, and T t, form the combination already described (III.), and shown in fig. 153; and the point P, found as already shown, is guided in a vertical line, almost exactly straight. The total length of the beam arm, c A, is fixed by the proportion

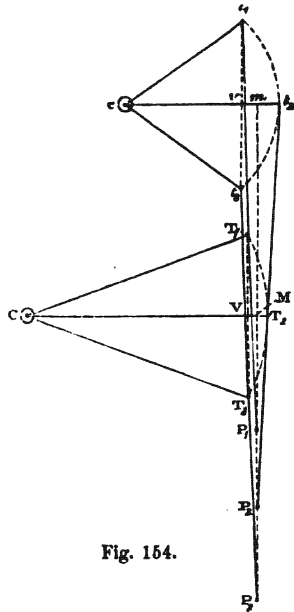

Fig. 154.

$$\overline{P t} : \overline{T t} :: \overline{C t} : \overline{C A}; \dots\dots\dots(6.)$$

that is, t A is very nearly a third proportional to C T and c t. Draw A B || T t, and c P B intersecting it; then from the proportion 6 it follows that A B = T t. A B is the *main link*: B, the head of the

piston rod. $\overline{BT} =$ and $\parallel \overline{tA}$ is the *parallel bar*, by which the main and back links are connected. P moves sensibly in a straight line; $\frac{cB}{cP} = \frac{cA}{ct}$ is a constant ratio; therefore B moves sensibly in a straight line parallel to that in which P moves.

A *parallelogram* analogous to $ABTt$ may also be combined with the parallel motion IV.

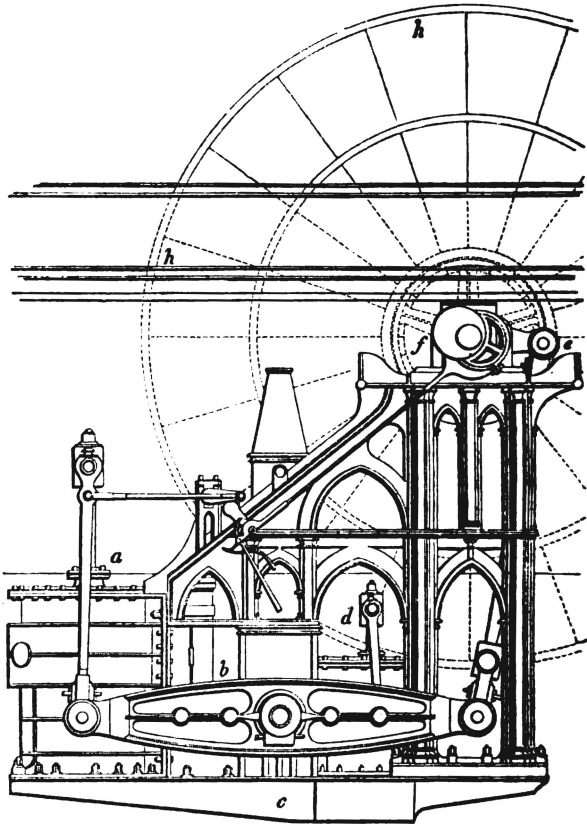

Fig. 156.

375. **Side Lever Engines** are a variety of beam engines much used in paddle steamers. Figs. 156 and 157 represent the general

arrangement of a pair of such engines, driving a pair of cranks at right angles to each other: fig. 156 being a side view of the port

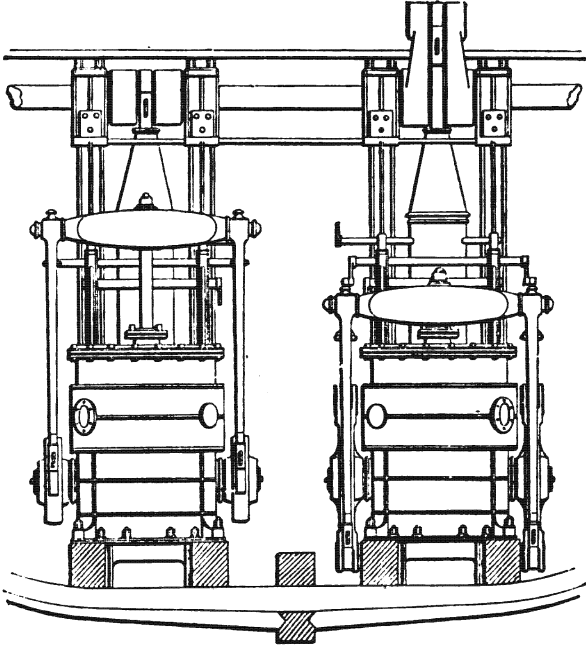

Fig. 157.

engine, and fig. 157 a view of the cylinder ends of both engines. Each engine has a pair of *side levers* or beams below the level of the shaft and of the cylinder cover; they are fixed on the opposite ends of one rocking shaft, which is the main centre. The piston rod carries a *cross-head*, like that of the letter T, from the ends of which hang a pair of *side rods*, connecting it with the ends of the pair of side levers. The opposite ends of the side levers are connected with a *cross-tail*, which, being fixed on the lower end of the connecting rod, gives it the shape of the inverted letter J. In fig. 156, *a* is the cylinder, *b* one of the side levers, *c* the sole plate with vertical flanges, which carries the engines and their frame; *d* the air pump rod with its cross-head and side rods, *e* the crank, *h h* a paddle wheel, *f* an eccentric with its counterpoise.

376. Varieties in Direct Acting Marine Engines are so numerous that they would require a separate treatise for their description. The objects aimed at in them are, in paddle steamers, length of stroke, notwithstanding limited head room; and in screw steamers, compactness and convenience, especially in ships of war, where the whole engine has to be placed below the water line. Some of them

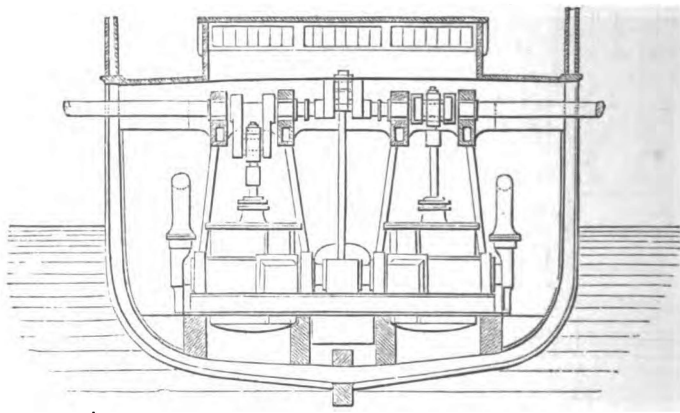

Fig. 158.

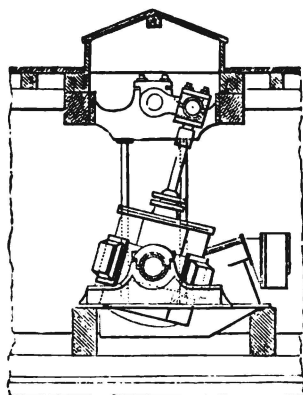

Fig. 159.

a pair of Messrs. Maudslay's double cylinder engines, in which there are four cylinders, two for each engine. Fig. 163 shows the

have been sufficiently described under the head of *cylinders*, Articles 353, 354, 355, 358. Fig. 158 is a cross-section, and fig. 159 a side view, of a pair of oscillating engines, such as have been mentioned in Article 358. The air pump is worked by a crank in the middle of the shaft. Figs. 160 and 161 represent a pair of "steeple engines," in which, from each cylinder, a pair of long piston rods rise on opposite sides of the shaft, and also of the crank, carrying a cross-head from which the connecting rod hangs downwards. In fig. 161 is seen the air pump, worked by a lever and links. Figs. 162 and 163 represent

two similar and equal cylinders that belong to one engine, standing side by side; their pistons move together, and they act in all

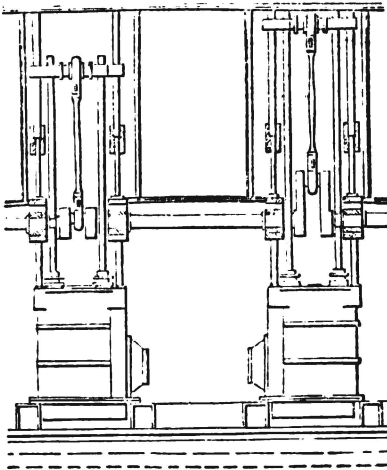

Fig 160.

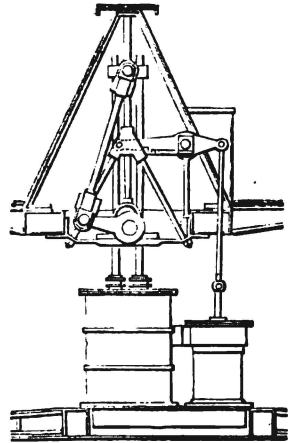

Fig. 161.

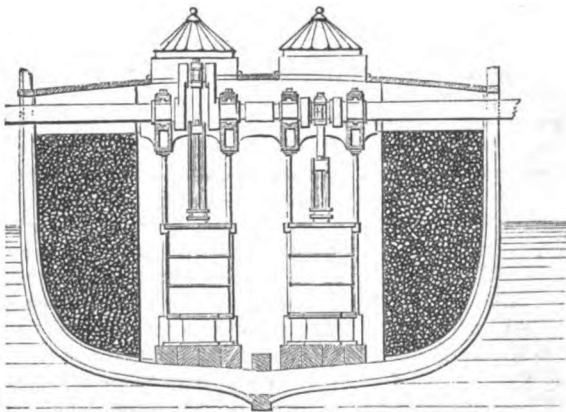

Fig. 162.

respects like two parts of one cylinder. Their two piston rods are fixed to the cross-head of a pair of T-shaped pieces, the lower ends of the stems of which move in vertical guides in the space between

the cylinders, and give motion through the connecting rod to the crank. The air pump is worked through a lever and links.

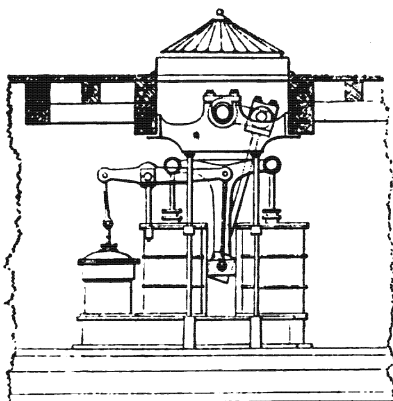

Fig 163.

its independent bearings. The middle piece, called the *intermediate shaft*, or *engine shaft*, is in permanent connection with the pistons through the connecting rods. The two outer pieces, called the *paddle shafts*, carry the paddle wheels: they have cranks upon their inner ends, which can be at will connected with and disconnected from the crank pins of the cranks of the engine shaft. The details of the method of doing this vary very much in the practice of different engineers.

In screw engines also, the *engine shaft* and *screw shaft* can be connected and disconnected by various contrivances.

378. **Strength of Mechanism and Framing.**—The principles upon which the strength of mechanism depends have been explained in Section 8 of the Introduction; and it has also been shown how they are to be applied to the principal pieces which occur in the mechanism of steam engines, such as piston rods, connecting rods, cross-heads, cross-tails, beams, cranks, axles, wedges, keys, &c.

Care must be taken in all calculations on this subject, to consider all the variations which the forces acting amongst the pieces of the mechanism undergo, whether in magnitude or in direction, and to take into account that condition of those forces in which the stress produced by them is the most severe. Care must also be taken not to consider efforts and resistances alone, but the entire forces applied to each piece, whether direct or lateral (Article 8, page 6; Article 23, page 31). For example, it is not the mere effort in the direction of motion of the crank pin which is to be considered in

The simplest arrangement of direct acting screw engines used in merchant vessels will be illustrated in a subsequent Article. In ships of war, those engines are brought below the water line, generally by placing their cylinders either horizontal or very much inclined. Contrivances for this object have given rise to an incalculable variety of forms of engine.

377. **Coupling Shafts of Marine Engines.**—In paddle engines, the shaft consists of three pieces, each with

of three pieces, each with

determining the requisite strength of the crank, but the whole thrust or pull exerted along the connecting rod.

The framework by which a moving piece is held or supported, exerts upon that piece a force or forces sufficient to prevent it from being dislodged from its proper bearings, and must be made sufficiently strong to bear with safety all the forces exerted by other bodies upon the moving pieces which it carries.

For example, in a beam engine, the principal parts of the framework are, the sole or base, and the pillars for alternately supporting and holding down the main centre of the beam. At one end of the base, the cylinder must be fixed down to it by bolts capable of safely resisting an upward pull equal to the greatest effort on the piston. At the other end, the bearings of the shaft must be fixed down with equal firmness. The supports of the main centre must be strong enough to bear the forces acting upon it, determined in the manner explained in Article 370. The base itself must possess transverse strength sufficient to bear safely the tendency of the forces applied to its ends and middle to break it across, producing a *moment of flexure* (Article 73, page 75) at each instant, equal and opposite to that which acts on the beam.

Similar principles apply to the side lever engine, except that the pillars support and hold down the bearings of the engine shaft.

In a direct acting engine, the principal parts of the frame are the pillars or rods by which the cylinder and the shaft are kept in their proper relative positions, and which have to resist a pull and a thrust alternately.

379. Balancing of Mechanism.—All the moving parts in an engine ought as far as possible to be *balanced*; that is to say, that every axis about which moving parts turn or vibrate, or have a reciprocating motion, should either exactly or as nearly as possible traverse the common centre of gravity of all the parts that its bearings support, and be a *permanent axis* of those parts which turn with it. The reasons for doing this, and the principles according to which it is to be effected, have been explained in Articles 21, 22, pages 27 to 30. It is of special importance as applied to the crank shaft.

The weight of, and the centrifugal force and couple produced by, any mass which is fixed to the shaft and rotates along with it, such as a crank or eccentric, can easily be balanced by counterpoises fixed to and rotating along with the shaft also. In the case of a mass which only partially partakes of the motion of the shaft, such as a piston, the balance of weight and inertia cannot be exactly realized in all positions of the engine, but must be approximated to in the way which may seem best to the judgment of the engineer.

In Article 347 it has been shown how the weight of the piston in vertical cylinders is approximately balanced by a proper adjustment of the pressure of the steam. In this case it is probably best, in order to avoid horizontal vibrations, that the weight of the piston, its rod, and half the connecting rod, should be balanced by steam

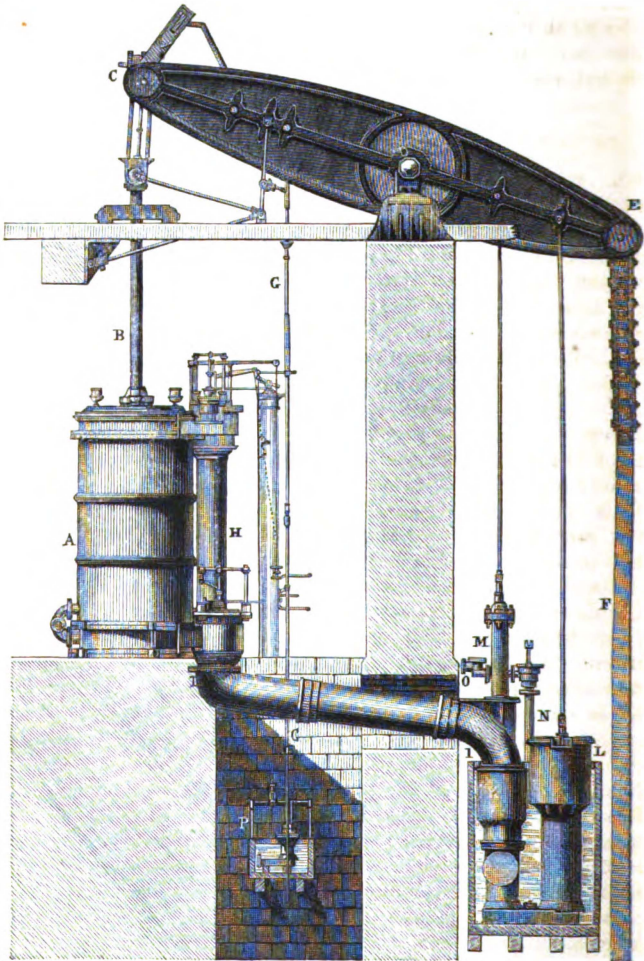

Fig. 164.

pressure alone, the crank and the other half of the connecting rod being balanced by counterpoises fixed on the shaft. In engines with horizontal cylinders, on the other hand, it is probably best to treat the whole weight of the piston, piston rod, and connecting rod, as if it were concentrated at and revolved along with the crank pin, and to fix counterpoises on the shaft suited to that supposition; and this method, or one not greatly differing from it, appears to have been practised by Messrs. Bourne & Co. in their horizontal single cylinder screw engine, with good results.

SECTION 6.—*Examples of Pumping and Marine Engines.*

380. **Examples of a Cornish Pumping Engine.**—Figs. 164, 165, and 166, represent a single acting non-rotative beam engine, known as the "Cornish engine," and used for draining mines, and for supplying towns with water.

Fig. 164 is a general elevation or side view.

Fig. 165 is an elevation, and fig. 166 a plan, of the valve gear.

As to the general arrangement of the valve gear, see Articles 342 and 343.

A is the cylinder; B, the piston rod; C D E, the beam; F, the main pump rod; G, the tappet rod or plug rod; H, the equilibrium pipe, which, when the equilibrium valve is open, connects the top and bottom of the cylinder; I, the exhaust pipe; K, the condenser; L, the air pump; M, the feed pump; N, its supply pipe; and O, its discharge pipe.

P is the "cataract," as to the general nature of which see Article 343. Q, the chest of the throttle valve; *a*, its spindle; *b c*, a lever; and *d d*, a rod and handle to adjust its opening; Z, the passage through which it communicates with the steam valve box R. S, the equilibrium valve box. T, the exhaust valve box.

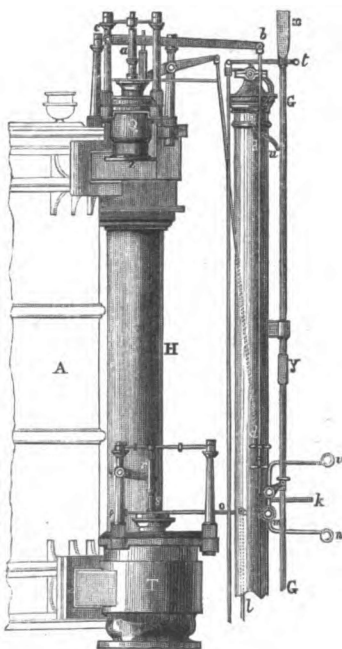

Fig. 165.

e is the pump of the cataract, standing in a small tank; its piston rod is attached to an arm projecting from the rocking shaft *ff*.

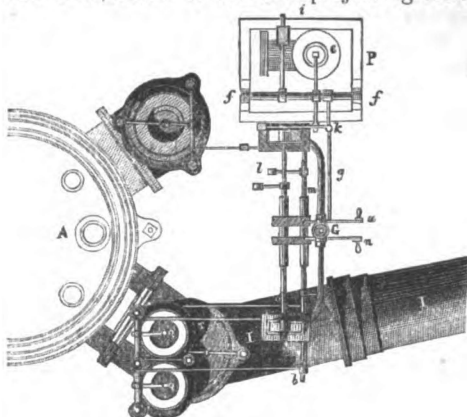

Fig. 166.

From that shaft there projects another lever *g*, which is depressed by the tappet rod *G* when near the bottom of its down stroke, so as to lift the piston of the pump. A third arm projecting from the same shaft *ff* carries a weight *i*, which, as soon as the tappet rod begins to rise and leave the lever *g* free, causes the piston to descend slowly.

Meanwhile the tappet rod, when at the bottom of its descent, has shut the exhaust valve by means of the tappet *y*, and opened the equilibrium valve: the piston has ascended; and at the top of the up stroke the tappet rod has shut the equilibrium valve, so that the engine is ready to begin a new stroke so soon as the exhaust valve and steam valve shall be re-opened.

The weight *i* continues to press down the cataract piston, and to cause the lever *g* to rise. This lever supports a small vertical rod, hidden in fig. 165 behind the tappet rod *G*, from which small rod there projects a peg, that at length lifts the lever *k*. From the lever *k* there projects a catch that holds a tooth projecting from the rocking shaft *m*, and prevents that shaft from turning under the action of the loaded rod *l* that hangs from a short lever projecting from the shaft *m*. When the lever *k* is lifted, the shaft *m* is set free, whereupon *l* descends, *m* turns, the handle *n* projecting from *m* rises; the short lever projecting from *m* pulls the loaded rod *op* towards the right of the figure, which, through the bell crank *pqr*, lifts the spindle *s* of the exhaust valve, and opens that valve so as to let the steam from below the piston escape to the condenser.

The before-mentioned vertical rod resting on *g* continues to rise; a peg projecting from it lifts the lever *t*, similarly placed to *k*, but higher, and in the same manner as a catch on *k* liberates a weight whose descent opens the exhaust valve, a catch on *t* liberates a weight whose descent opens the steam valve. The steam is admitted, and the down stroke begins.

At a point of the down stroke fixed by adjusting the position of the long tappet x on the tappet rod, that tappet presses down the handle u as to shut the steam valve, and hold it shut for the remainder of the stroke, which is performed by expansion.

As the down stroke is completed the cycle of operations already described recommences.

The ascent of the piston while the equilibrium valve is open is produced by a slight preponderance of the weight of the main pump rod and its load above the weight and resistance of the column of water which the plungers raise. The energy exerted by the steam on the piston during the down stroke is stored in lifting the pump rod and its load, as has been explained in Article 32, page 37. The cylinders of Cornish engines are jacketed above, below, and all round, and clothed with felt and planking.

In *direct acting* non-rotative pumping engines the up stroke is the effective stroke, the steam being admitted and expanded below the piston, then passed by the equilibrium valve from the bottom to the top of the cylinder, and then discharged into the condenser. The arrangement of the mechanism somewhat resembles that of the water pressure engine in Article 132, fig. 40—except that in general the piston rod proceeds upwards through a stuffing-box in the cylinder cover, and carries at the top a cross-head, from the ends of which hang links, attached at their lower ends to the cross-head of the pump rod. Another arrangement is, to have a pair of similar and equal cylinders, standing side by side, whose piston rods support the ends of a cross-head, from the middle of which the pump rod hangs.

381. **Double Acting Pumping Engines** are now very common, in which the piston rod of a double acting pump is continuous with that of the engine. Such engines are rotative, having a fly-wheel driven by means of a crank for the purpose of making the motion steady. The cylinder and pump are often horizontal.

382. **Example of Vertical Inverted Screw Marine Engines.**—Figs. 167 and 168 represent the pair of engines of the "Indian Queen," by Messrs. Neilson & Co. These engines have been selected for the purpose of illustration, because they are very good and efficient specimens of engines for a screw merchant steamer, and at the same time contain nothing unusual in their parts or arrangement.* Fig. 167 shows a front elevation, and a vertical section of part of the forward cylinder and part of the valve chest. Fig. 168 is a side elevation looking towards the head of the ship. The scale is $\frac{1}{16}$ of the real dimensions. Each cylinder has an ordinary slide valve moved by a link motion (Article 348), and a gridiron ex-

* Through inadvertence, figs. 167 and 168 have been reversed as to right and left; so that, while the actual engines face to port, the figures show them as facing to starboard.

pansion slide valve worked by a separate eccentric (Article 350). The cylinders are steam jacketed, and also clothed in felt and wood.

A, A, are the cylinders. B, part of the piston of the forward engine. C, C, cylinder ports. D, exhaust port. E, ordinary slide valve. F, gridiron expansion valve.

G, G, G, G, are the eccentric rods of the two link motions for working the ordinary slide valves. Of these rods only one is shown

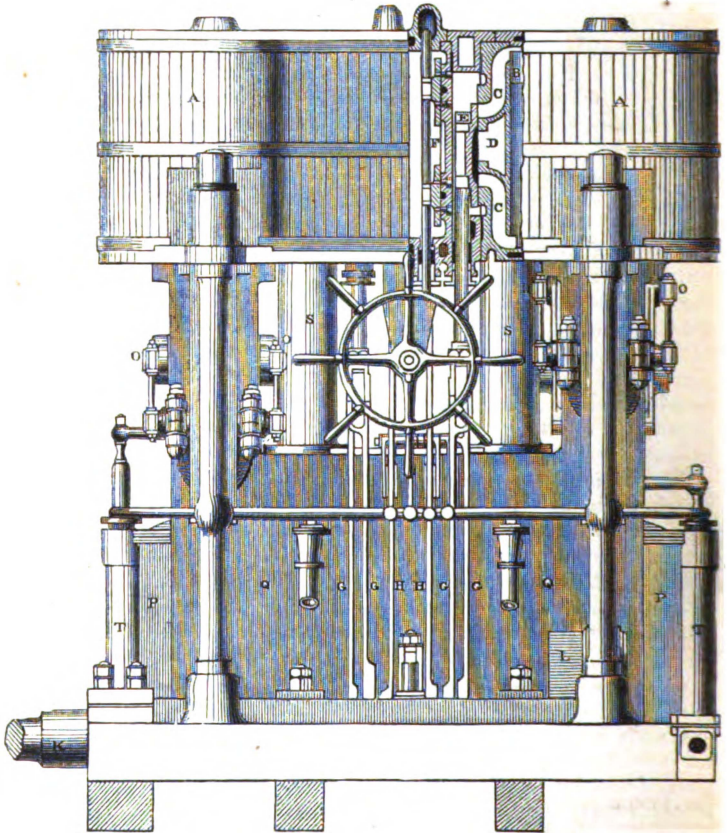

Fig. 167.

in fig. 168. H, H, eccentric rods of the two expansion valves. K, the shaft.

L, in fig. 167, the fore crank. L, in fig. 168, the after crank, dotted.

M, in fig. 168, the aft connecting rod.

N, in fig. 168, the aft piston rod.

In fig. 167 the piston and connecting rods are hidden by pillars of the frame and guides. O are levers driven by links connected with

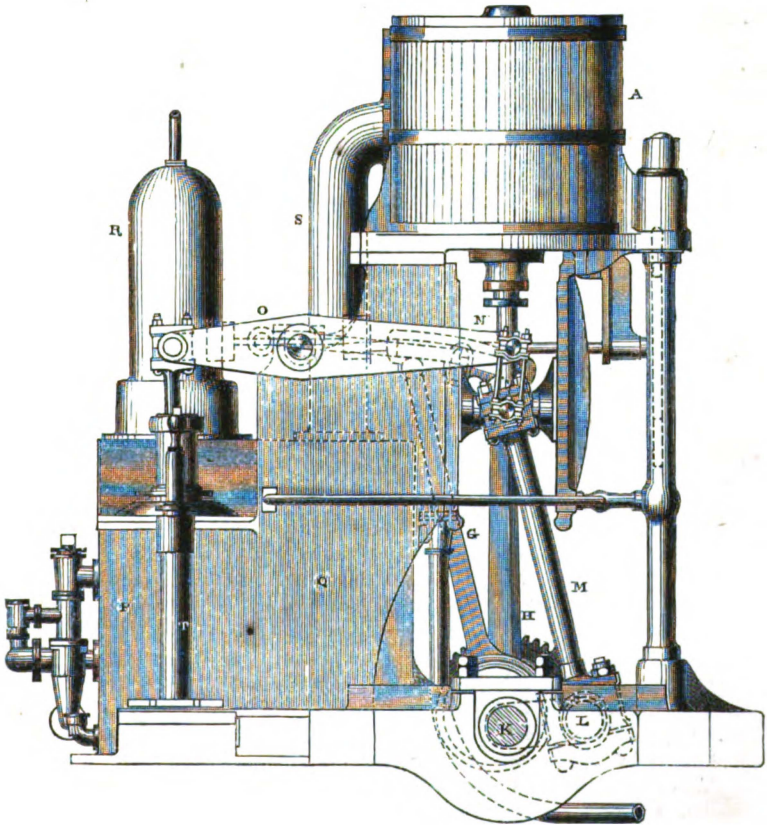

Fig. 168.

the piston rod heads to work the pumps. P, P, air pumps. Q, condenser. R, hot well with air vessel above.

S, S, exhaust pipes of cylinders.

T, T, feed pumps, worked by rods attached to cross-heads on the air pump trunks.

U, wheel to turn the screw which shifts the links of the link motions when the engines are to be reversed or stopped, the valve rods being at rest laterally.

This pair of engines, when making 75 revolutions per minute, with a ratio of expansion of 5, is of 320 indicated horse-power, and burns 3 lbs. of coal per indicated horse-power per hour; the efficiency of the steam, and of the furnace and boiler, as well as the rate of expansion, being almost exactly the same as in the engines referred to in Article 289, Example I., pages 405, 406.

SECTION 7.—*Locomotive Engines.*

383. **Reference to Previous Articles.**—Besides the general characteristics which locomotive engines possess in common with other steam engines, the peculiarities of those engines have been frequently referred to in previous parts of this work, and especially in the following places:—

Article 229, page 281 (supply of air to fuel).

Article 230, pages 282, 283 (distribution of air, and contrivances to prevent smoke.)

Article 232, page 285 (rate of combustion).

Article 234, Division IV., pages 293 to 297, especially examples IV., V., VI., VII., VIII. (efficiency of furnace and evaporative power of fuel).

Article 280, pages 382, 383 (back pressure).

Article 286, page 396 (use of heating the cylinder externally).

Article 289 A, page 412 (use of high pressure condensation).

Article 290, pages 413 to 416 (resistance of the regulator).

Articles 303, 304, 305, pages 449 to 452 (furnace and boiler).

Article 306, page 456 (grate and its ash-pan).

Article 308, page 457 (height of furnace).

Article 312, page 459 (fire-box stays).

Article 312, page 460 (tubes and boiler shell).

Article 315, page 463 (boiler room).

Article 317, page 465 (safety valves).

Article 341, page 485 (throttle valve).

Article 347, pages 491 to 496 (expansion by the link motion).

384. **Adhesion of Wheels.**—The tractive effort which a locomotive engine can exert is limited, not only by a quantity depending on the dimensions of the cylinder and driving wheels and the effective pressure of the steam, but also by the *adhesion* between the driving wheels and the rails, which means the friction between them, acting so as to prevent slipping. If the resistance of the load drawn exceeds the adhesion, the wheels turn round without advancing.

The adhesion is equal to the product of that part of the weight of

the engine which rests on the driving wheels into a co-efficient of friction which depends on the condition of the surfaces of the wheels and rails. The value of that co-efficient is from 0.15 to 0.2, when wheels and rails are clean and dry; but when they are damp and slimy, or in the condition called "greasy," it diminishes sometimes to 0.07 or 0.05. About 0.1 may be considered an average ordinary value.

The proportion of the weight of the engine which rests on the driving wheels depends on the number and arrangement of the wheels, the number of pairs driven by the engine, and the distribution of the load upon them. The number of wheels ranges from two to five pairs—the most common number being three pairs—of these from one pair to the whole are driven by the engine. The proportion of the weight of the engine which rests on the driving wheels may be estimated to range from one-third to the whole. One-half is probably the most usual proportion in six-wheeled engines with one pair of driving wheels under the middle of the engine, which is the most common arrangement in passenger engines; two-thirds, in six-wheeled and eight-wheeled engines with two pairs of wheels coupled so as to be driven by the engines, which is a common arrangement in goods engines. Engines with all the wheels coupled are used for slow and heavy trains, and in them, of course, the whole weight rests on driving wheels.

The weights of locomotive engines range from 5 to 40 tons in extreme cases; but the most ordinary weights are from 20 to 25 tons. When the stock of fuel and water are carried in a tender, the weight of the engine itself is alone available to produce adhesion, unless, as is sometimes the case on very steep railways, the wheels of the tender are coupled to those of the engine by gearing chains and pulleys. Some engines, called tank engines, carry their own stock of fuel and water—the fuel on the platform behind the fire-box, and the water in a tank above the barrel of the boiler—and in them the adhesion is greatest on first starting from a station where fuel and water are taken in, and gradually diminishes as the stock is consumed.

385. **Resistance of Engines and Trains.**—The authority now chiefly relied upon for the resistance of engines and trains on railways is that of a series of experiments by Mr. Gooch on the broad gauge. The following empirical formula represents with tolerable accuracy the results of those experiments:—

Let E be the weight of the engine and tender in *tons*.

T , the weight of the train in *tons*.

V , the velocity in *miles an hour*.

i , the inclination of the line, expressed as a fraction; ascents being considered as positive, and descents as negative.

Resistance of the train in lbs.

$$= \{6 + 0.3(V-10) \pm 2240 i\} T; \dots\dots\dots(1.)$$

Resistance of the engine and tender in lbs.

$$= \{12 + 0.6(V-10) \pm 2240 i\} E; \dots\dots\dots(2.)$$

Total resistance in lbs.

$$= \{6 + 0.3(V-10)\} (T + 2 E) \pm 2240 i (T + E) \dots\dots\dots(3.)$$

At velocities less than ten miles an hour the term containing $V-10$ is to be omitted: the resistance being sensibly constant below that speed.

Mr. D. K. Clark prefers to such formula as the above, another set of formulæ in which the resistance is treated as consisting of a constant part, and a part increasing as the square of the speed; as follows:—

$$\text{Resistance of train, in lbs.} = \left(6 + \frac{V^2}{240} \pm 2240 i\right) T; \dots\dots\dots(4.)$$

Resistance of engine and tender, in lbs.

$$= \left(6 + \frac{V^2}{240} \pm 2240 i\right) E + \left(2 + \frac{V^2}{600}\right) (T + E); \dots\dots\dots(5.)$$

The second term of this is the resistance of the mechanism.

$$\text{Total resistance, in lbs.} = \left(8 + \frac{V^2}{171} \pm 2240 i\right) (T + E) \dots\dots\dots(6.)$$

The resistance on a curve exceeds that on a straight line, according to experiments by Lieutenant David Rankine and the Author, made at low velocities, to the amount of

$$\frac{1.4 \text{ lb. per ton}}{\text{radius of curve in miles}} \dots\dots\dots(7.)$$

The mean effective effort of the steam on the pistons required to overcome a given total resistance of engine and train is given by the following equation, in which A is the *total area of both pistons*, and $p_m - p_s$ the *mean effective pressure*.

$$A(p_m - p_s) = \frac{\text{Total resistance} \times \text{circumference of driving wheel}}{2 \times \text{length of stroke of piston}} \dots\dots\dots(8.)$$

386. **The Balancing of Engines**, both as to centrifugal forces and centrifugal couples, is of great importance as a means of preventing dangerous oscillations. The principle according to which it is effected is, to conceive the mass of the pistons, piston rods, and

connecting rods, and a weight having the same statical moment as the crank, as concentrated at the crank pins, and to insert between the spokes of the driving wheels counterpoises whose weights and positions are regulated by the principles explained in Articles 21 and 22, pages 27 to 30.

The following are the formulæ to which these principles lead:—

DATA—

W , total weight conceived to be concentrated at one crank pin.

c , length of the crank, measured from the axis of the axle to the centre of the crank pin.

a , distance of the centre of the crank pin, measured parallel to the axle, from the middle of the length of the axle.

b , distance of the centre of a wheel from the middle of the length of the axle.

r , radius-vector of each counterpoise; being the distance of its centre of gravity from the axis of the axle.

REQUIRED—

i , angle which that radius-vector makes with a plane traversing the axis in a direction midway between the directions of the two cranks, and pointing the opposite way to those directions. The cranks being at right angles to each other, make angles of 135° with the plane in question.

w , weight of each counterpoise.

RESULTS—

$$i = \arctan \frac{a}{b}; \dots \dots \dots (1.)$$

$$w = W \cdot \frac{c}{r} \cdot \sqrt{\frac{a^2 + b^2}{2b^2}} = \frac{Wc}{\sqrt{2} \cdot r \cos i} \dots \dots \dots (2.)$$

In practice, those formulæ may be used to find a first approximation to the required position and weight of the counterpoises; but the final adjustment is always performed by trial; the engine being hung up by chains attached to the four corners of its frame, and the machinery set in motion: a pencil attached to the frame near one angle, marks, on a horizontal card, the form of the oscillations, being usually an oval; and the counterpoises are adjusted until the orbit described by the pencil is reduced to the least possible magnitude. When the adjustment is successful, the diameter of that orbit is reduced to about $\frac{1}{16}$ of an inch.

387. The **Blast Pipe** has the effect of adjusting the draught of the furnace, and consequently the rate of consumption of fuel, to the work to be performed by the engine with very different loads, and at very different speeds; and is on that account perhaps the most important of the peculiar parts of the locomotive engine.

Its effect upon the back pressure in the cylinder has already been considered in Article 280, pages 382, 383.

The effect of the blast pipe in producing a draught depends upon its own diameter and position, on the diameter of the chimney, and on the dimensions of the fire-box, tubes, and smoke-box. Mr. D. K. Clark has investigated the influence of these circumstances from his own experiments, and from those of Messrs. Ramsbottom, Polonceau, and others, and has shown that the vacuum in the smoke-box is about 0·7 of the blast pressure: that the vacuum in the fire-box is from $\frac{1}{3}$ to $\frac{1}{2}$ of that in the smoke-box: that the rate of evaporation varies nearly as the square root of the vacuum in the smoke-box: that the best proportions of the chimney and other parts are those which enable a given draught to be produced with the greatest diameter of blast pipe, because the greater that diameter, the less is the back pressure produced by the resistance of the orifice: that the same proportions are best at all rates of expansion and at all speeds: and that the following proportions are about the best known:—

Sectional area of tubes within ferules,..... = $\frac{1}{5}$ area of grate.

Sectional area of chimney, = $\frac{1}{15}$ area of grate.

Area of blast orifice (which should be
somewhat below the throat of the
chimney,.....) } = $\frac{1}{66}$ area of grate.

Capacity of smoke-box,..... = 3 feet x area of grate.

Length of chimney,..... = its diameter x 4.

If the tubes are smaller, the blast orifice must be made smaller also; for example, if

Sectional area of tubes within ferules..... = $\frac{1}{10}$ area of grate,

Then area of blast orifice = $\frac{1}{90}$ area of grate.

388. **Examples of Locomotive Engines.**—The examples here given are from two locomotive engines by Messrs. Neilson & Co., which are selected, like the screw marine engines of Article 382, because they are good and efficient specimens of the class of engines to which they belong, and have nothing unusual in their proportions and arrangements.

Fig. 169 is a side view copied from a photograph of a six-wheeled engine, with two pairs of wheels coupled. Its scale is about $\frac{1}{4}$ of the real dimensions.

Fig. 170 is a longitudinal section of an engine of the same class with the preceding, but with somewhat larger driving wheels, being

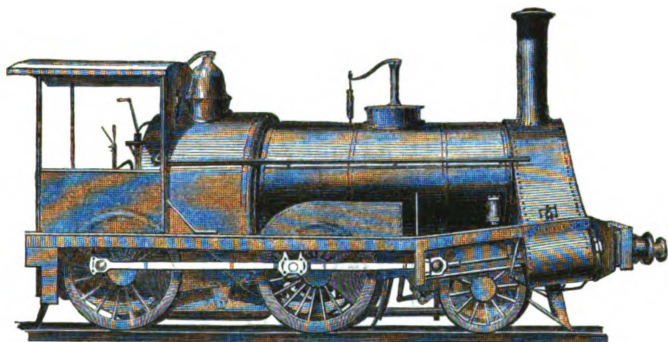

Fig. 169.

intended for a less steep line and higher speeds. The scale is $\frac{1}{16}$ of the real dimensions. The details of the valve gearing are omitted.

Fig. 171 shows, at the left-hand side, a cross-section through half the fire-box, and at the right-hand side, a cross-section through half the smoke-box, of the same engine.

Fig. 172 is an elevation of the valve gearing of one cylinder, with the cover taken off the valve chest to show the slide valve and ports.

Fig. 173 shows a plan of the valve gearing of one cylinder, and a longitudinal section of the cylinder and valve chest.

The scale of figs. 171, 172, and 173, is $\frac{1}{16}$ of the real dimensions.

A is the ash-pan; B, the grate; C, the fire-box. In fig. 170, the heads of the bolts which tie the outer and inner shells of the fire-box together are irregularly placed; but that is an oversight in the engraving; they ought to be ranged in vertical and horizontal lines. D is the fire-door.

E are the tubes, extending from the fire-box to the smoke-box F. G is the lower end of the chimney.

I is one of the horizontal feed pumps, worked by a link from one of the eccentrics. H is the supply pipe from the water tank of the tender; K, the feed pipe, leading to the boiler.

L is the water space round the fire-box; M, the water space and steam space above it.

N are longitudinal ribs, to which the crown of the fire-box is stayed, as explained in Article 312, page 459. The crown receives

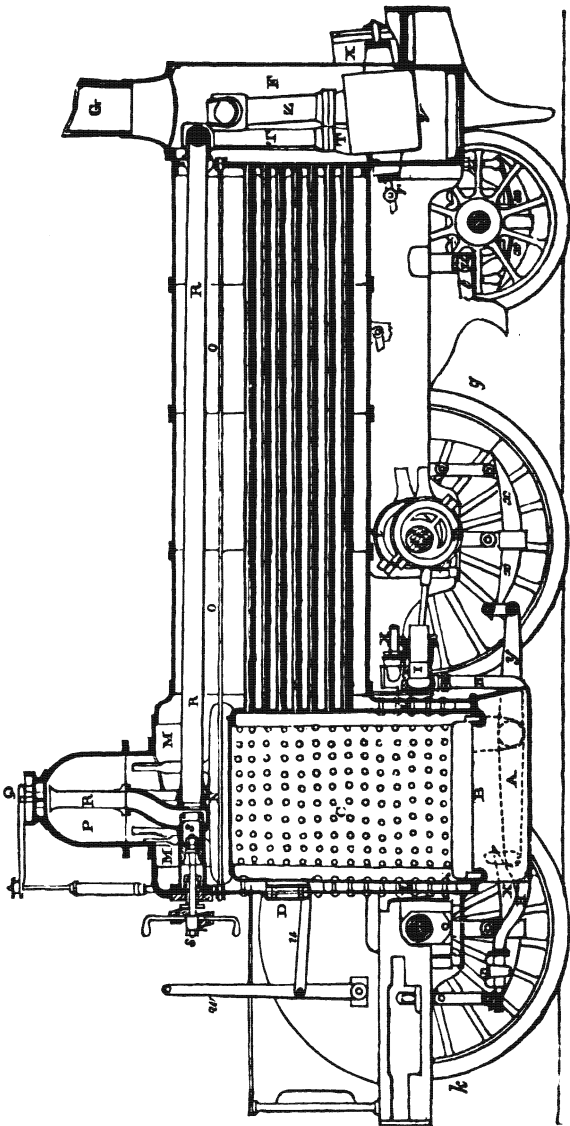

Fig. 170.

additional support from vertical stay bars, hanging from the sides of the steam dome.

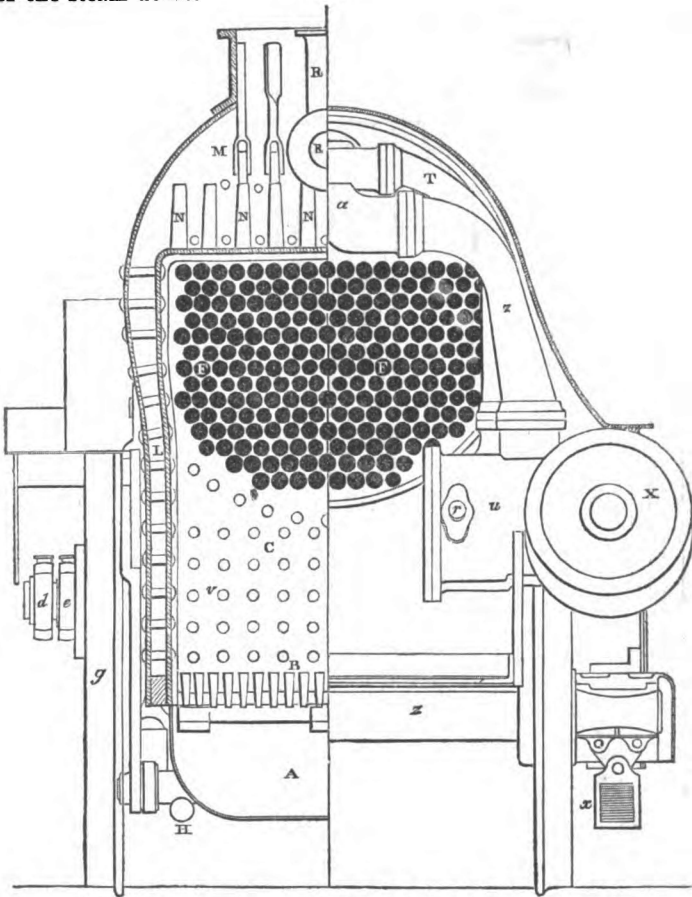

Fig. 171.

O is the space above the tubes, in the barrel of the boiler. P is the steam dome, on the top of the external shell above the fire-box. This part of the shell in the engine represented is of a radius a little greater than the barrel of the boiler; but in many engines (for example, those of Messrs. Kitson & Co.) it is made of the same radius.

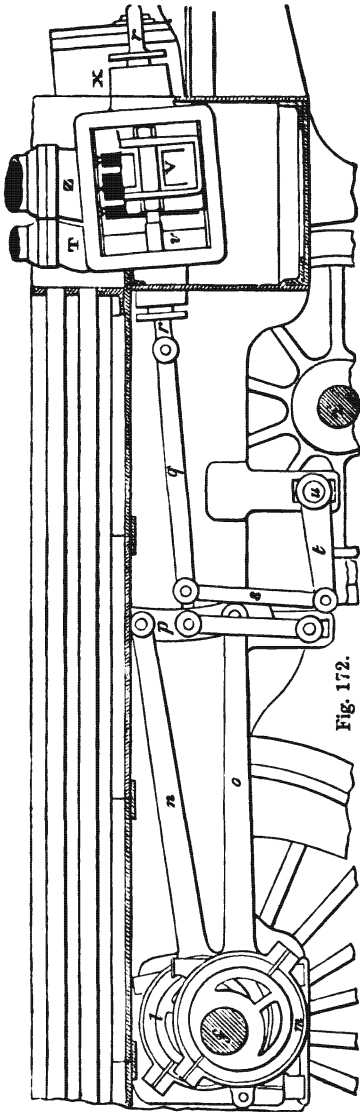

Fig. 172.

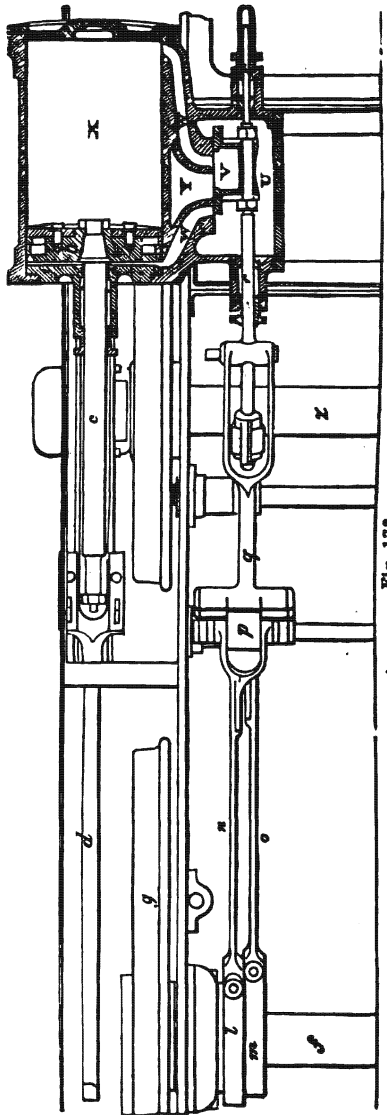

Fig. 173.

Q is one of the safety valves. The other safety valve is omitted in fig. 170, but shown in fig. 169, as standing on the middle of the barrel of the boiler.

R, R, R, is the steam pipe, bringing steam down from the dome, and along the top of the barrel.

S, S, the regulator, a conical valve worked by a screw. T, branch steam pipe; U, slide valve chest; V, slide valve; W, W, cylinder ports; X, cylinder; Y, exhaust port; Z, exhaust pipe. The two exhaust pipes unite in the blast pipe *a*.

b, piston; *c*, piston rod; *d*, connecting rod, driving a crank on the front driving axle *f*; *e*, coupling rod, connecting cranks on the front driving axle *f*, and hind driving axle *h*. *g*, front driving wheel; *k*, hind driving wheel.

l, forward eccentric, and *m*, backward eccentric, of the left slide valve. *n*, forward eccentric rod; *o*, backward eccentric rod. These rods are jointed to the two ends of the link *p*, which is jointed at the centre to and supported by a nearly vertical bridle or lever, oscillating about a fixed centre. *r* is the slide valve rod, and *q* the connecting rod, through which the rod *r* receives motion from a slider in the link *p*. The radius of the centre line of the link is the length of the rod *q*. The slider and the rod *q* are shifted into different positions, so as to alter the expansion or reverse the engine when required (as explained in Article 348, page 497) by means of the rod *s*, connected with the lever *t*. A pair of those levers, to act on the two link motions at once, project from the rocking shaft *u*. On the left-hand outer end of that shaft is a vertical lever, connected through a long rod *v* (partly seen in fig. 170), with the handle *w*, by means of which the engine driver controls the link motion. When that handle is pushed forward or pulled back as far as it can go, the engine is in full forward or full backward gear respectively; and intermediate positions give various rates of expansion in forward or backward gear, according as the handle is before or behind its middle position.

x, *x*, *x*, are the springs; *y*, a balance lever to distribute the load equally between the two pairs of driving wheels, notwithstanding irregularities in the surface of the rails; *z*, training axle and wheel.

389. **Locomotive Engines for Common Roads** of various forms have been invented by Mr. Gurney, Sir James Anderson, Mr. Scott Russell, and many other inventors, and were at one time constructed and used to some extent. For many years they fell into disuse; but have been revived in the form of Mr. Boydell's "traction engine." This machine is adapted to drawing long trains of heavy laden vehicles at a low speed, such as four or five miles an hour, and appears to have been quite successful. To insure that the driving wheel shall take a sufficient hold of the road, without

injuring its surface, that wheel successively sets down in front of itself, runs over, and picks up again, a series of flat oblong plates or shoes, which form a sort of endless tramway for the wheel to run upon, and enable it not merely to travel on roads, but on rough and soft ground.

SECTION 8.—*Of Steam Turbines.*

390. The **Reaction Steam Engine**, in a rude form, is described in the *Pneumatics* of Hero of Alexandria. It was improved and brought into use to a limited extent by Mr. Ruthven. Its principle and mode of action are analogous to those of a reaction water wheel (Article 171, page 190; Article 176, page 197), but existing experimental data are not sufficient to form a precise theory of it.

391. The **Fan Steam Engine**, invented by Mr. William Gorman, is analogous in its principle and mode of action to an *inward flow* water turbine (Article 171, page 191; Article 173, page 193; Article 174, pages 194, 195, 196, &c.) It consists of an outer annular casing, which receives steam from the boiler, and discharges it in tangential jets from its inner surface; an inner cylindrical casing, having openings at the centre for the discharge of the waste steam; and a fan, consisting of scoop-shaped blades radiating from a shaft, which rotates within the inner casing, and is driven by the tangential jets of steam.

An engine of this kind was successfully used for some time at the Glasgow City Saw Mills, and was considered equal in efficiency to an ordinary high pressure engine; but (as in the case of the reaction steam engine), sufficient experimental data have not yet been obtained to complete a precise theory of its action.

ADDENDUM TO ARTICLE 316.

Feed Water Heating Vessels should have safety valves and pressure gauges.

ADDENDUM TO ARTICLE 376.

Amongst **Direct Acting Marine Engines** may be mentioned the triple engine of Mr. Scott Russell, in which three oscillating cylinders radiate in three equi-angular directions from a shaft, and drive one crank.

PART IV.

OF ELECTRO-MAGNETIC ENGINES.

392. **Introductory Remarks.**—Although the principles of the development of mechanical energy from chemical action through the agency of electric and magnetic forces might be made the subject of a voluminous treatise which would be highly interesting in a scientific point of view, the amount of experience of the actual working of electro-magnetic engines is not yet sufficient to supply those data which are necessary in order to render such a treatise practically valuable. In the present work, therefore, a brief outline only of those principles will be given, illustrated by descriptions of three forms of engine, two of which are selected on account of their simplicity, and probable efficiency, though hitherto used as pieces of philosophical apparatus only; and the third, on account of its having been for some years in practical operation.

The experimental data to be afterwards referred to are for the most part due to the researches of Dr. Joule and Dr. Andrews. The theory of the subject was first correctly set forth by Professor Helmholtz, and Professor William Thomson, in a series of papers published respectively in Poggendorff's *Annalen*, and in the *Philosophical Transactions* and *Philosophical Magazine*, especially two papers in the *Philosophical Magazine* for December, 1851. The summary of that theory which will be given is in the main extracted from a paper by the Author of this work "On the General Law of the Transformation of Energy" (*Phil. Mag.*, 1853).

393. **Energy, Actual and Potential.**—*Energy* has been defined in Article 25, page 32; and the distinction between actual and potential energy has been explained, so far as it relates to mechanical energy, or energy of motion and of force tending to produce motion, in the same Article, and in Article 31, pages 35, 36. It has further been explained in Article 196, page 224, and Articles 235, 236, pages 299, 300, that heat is a form of energy. In order to understand the application of certain general laws respecting energy to electricity and magnetism, the definitions of energy, actual and potential, must be extended so as to become perfectly general and abstract, as follows:—

A capacity for performing work is to be called **ACTUAL ENERGY**, when it consists in a state of present activity of a substance, such

as motion, heat, current electricity; and **POTENTIAL ENERGY**, when it consists in a tendency of a certain magnitude towards a change of a certain magnitude, such as mechanical potential energy (that is, weight or pressure capable of acting through a given space), chemical affinity, electrical tension, magnetic tension.

The *general law of the transformation of energy* has already been stated in Article 244, page 309. The principles which will be explained in the sequel are instances of its application to the actual energy of current electricity, and the potential energy of electro-magnetic attraction.

394. The **Energy of Chemical Action** is the source of the power of electro-magnetic engines, as it is of that of heat engines. *Chemical affinity*, or the tendency of two substances to combine chemically, is a sort of potential energy, which, when the substances actually do combine, is replaced by actual energy in the form of heat, or of current electricity, or of both combined. Examples of the quantities of energy in the form of heat produced by the combination of various substances with oxygen have been given under the head of "Combustion," in Articles 223, 224, pages 267 to 273; and those quantities can be expressed in foot-pounds of energy by multiplying by Joule's equivalent of a British thermal unit, 772.

It is sometimes difficult or impossible to obtain the whole energy produced by a given chemical combination at once in the form of heat. In that case, the energy may be obtained first in the form of current electricity, and reduced afterwards to the form of heat.

The following are the data of the greatest importance in the theory of electro-magnetic engines:—

I. Energy developed by the solution of one lb. of zinc in Daniell's battery, the liquid in the cells being a solution of sulphate of copper in water—

	British thermal units.
Heat produced by the oxidation of the zinc,	2342
Heat produced by the combination of the oxide of zinc with sulphuric acid,	} 664
	3006
<i>Deduct—</i>	
Heat consumed in decomposing sulphate of oxide of copper,	} 527
Heat consumed in decomposing the oxide of copper,	} 1060
	1587
	1419
$1419 \times 772 = 1,095,468$ foot-lbs. per lb. of zinc.	

This is *less than one-tenth* of the total energy developed by burning one lb. of carbon.

II. Energy developed by the solution of one lb. of zinc in Smee's battery, the liquid in the cells being dilute sulphuric acid—

	British thermal units.
Heat produced by the combination of zinc with } oxygen and sulphuric acid, as before,..... }	3006
<i>Deduct—</i>	
Heat consumed in separating water from sul- } phuric acid (about)	200
Heat consumed in decomposing water,.....	1906
	2106
	900

$$900 \times 772 = 694,800 \text{ foot-lbs. per lb. of zinc.}$$

This is about *one-sixteenth part* of the energy developed by burning one lb. of carbon.

395. **Comparative Cost of Working Electro-magnetic Engines and Heat Engines.**—It is certain that the *efficiency* can be made to approximate much more nearly to *unity*, the limit of perfection, in electro-magnetic engines than in heat engines. At present, however, the ratio of their efficiencies can only be roughly estimated; and it may be considered as a favourable view towards electro-magnetic engines, to estimate their greatest possible efficiency as *four times* that of the best heat engines yet known. Taking this into account along with the results of the calculations in the preceding Article, it appears that the *work performed per pound of zinc consumed* may be estimated as follows:—

I. With solution of sulphate of copper in the cells, $\frac{1}{16}$ of the work per lb. of carbon consumed in a heat engine.

II. With dilute sulphuric acid in the cells, $\frac{1}{16} = \frac{1}{4}$ of the work per lb. of carbon consumed in a heat engine.

Before, therefore, electro-magnetic engines can become equally economical with heat engines as to cost of working, their working expense per lb. of zinc consumed must fall until it is from *four-tenths to one quarter* of the working expense of a heat engine per lb. of carbon, or of coal equivalent to carbon.

The present price (September, 1859) of sheet zinc is between *fifty and sixty times* that of such coal.

It is evident from these facts and calculations, that electro-magnetic engines never can come into general use except in cases where the power required is so small that the cost of material consumed is of no practical importance, and the situation of the

machinery to be driven is such as to make it very desirable to have a prime mover without a furnace.

396. An **Electro-chemical Circuit** consists of a battery, with a conductor connecting its two ends; and its arrangement may be represented symbolically as follows:—

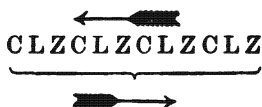

This represents a battery of four cells, each cell being denoted by the symbol C L Z. Z denotes a plate of zinc, the substance to be dissolved; L the solvent liquid, containing the substances that combine with the zinc; C a plate of copper, silver, or some such metal which has less affinity for the solvent than the zinc has, and which acts merely as a conductor. The brace $\underbrace{\hspace{10em}}$ represents symbolically a metallic wire connecting the ends of the battery. The chemical action of the solvent on the zinc puts the entire circuit into a peculiar condition described by saying, that there is a *current of positive electricity circulating through it*, in each cell, from Z through L to C, and in the conductor $\underbrace{\hspace{10em}}$ from C to Z: not that the existence of the so-called electric fluid or fluids has been proved, but that the use of terms borrowed from those which commonly denote the motion of fluids is a convenient way of describing electrical phenomena. The endmost portions of the conductor, where it joins the battery, are called the *electrodes*; the positive electrode joining C, the negative Z.

The *strength* of the electric current is a quantity proportional to the weight of some standard substance which it is capable of decomposing in an unit of time. It is expressed in *units* of such a kind, that a current of unit strength decomposes

$$\begin{array}{l}
 \cdot 02 \text{ grain of water per second, or} \\
 \cdot 0103 \text{ lb. of water per hour.}
 \end{array}$$

The strength of the current produced by a given battery is proportional to the quantity of zinc dissolved in a given time in *one cell*. To produce a current of unit strength requires the consumption in each cell of

$$\begin{array}{l}
 \cdot 0728 \text{ grain of zinc per second, or} \\
 \cdot 03744 \text{ lb. of zinc per hour.}
 \end{array}$$

Let γ denote the strength of the current; z the zinc consumed *per cell per hour*, in lbs.; then

$$\gamma = \frac{z}{.03744} \dots\dots\dots(1.)$$

The *electro-motive force* of a battery is a quantity such, that when it is multiplied by the strength of the current, the product is the energy produced by the battery in a given time (such as an hour). It is proportional to the number of cells.

Let M , then, denote the electro-motive force of one cell, n the number of cells; also, let E be the energy developed per lb. of zinc consumed, as stated in Article 394; then

$$M n \gamma = E n z. \dots\dots\dots(2.)$$

So that

$$M = .03744 E = \left. \begin{array}{l} \text{for Daniell's battery, } 41014; \\ \text{for Smee's battery, } 26013. \end{array} \right\} \dots(3.)$$

In these values of M , it is to be borne in mind, that the unit of force is *one pound weight*, and the unit of time *an hour*. In Professor Thomson's papers, the unit of force is $\frac{1}{32.2}$ of the weight of a grain, and the unit of time a second.

The heat produced in a given time by a given current in the same circuit is proportional to the square of the strength of the current. That quantity of heat, then, is expressed by

$$R \gamma^2; \dots\dots\dots(4.)$$

Where R is a quantity called the *resistance* of the circuit, being the heat developed in it in an unit of time by a current of unit strength.

The resistance of a circuit is the sum of the resistances of the various parts of which it consists, comprehending the plates and liquid of the cells, and the conductor which completes the circuit. The resistances of conductors made of a given substance are directly as their lengths and inversely as their sectional areas, or directly as the squares of their lengths and inversely as their weights. Let l be the length of any one conductor in a circuit, in feet, whether solid or liquid; w its weight, in lbs.; then

$$R = \sum \epsilon \frac{l^2}{w}; \dots\dots\dots(5.)$$

where ϵ is a co-efficient depending on the material, and called the *specific resistance* of that material. Professor Thomson gives values of ϵ in which the unit of force is $\frac{1}{32.2}$ of a grain weight, the unit

of mass, that of a grain, and the unit of time one second: to reduce these to values in which the unit of force is one pound weight, the unit of mass, that of a pound, and the unit of time one hour, they are to be multiplied by

$$\frac{3600}{32 \cdot 2 \times 49000000}$$

The following are examples of the results of that reduction for temperatures of 50° Fahrenheit:—

Copper wire, $e =$ from 176 to 128.

Mercury, $e = 10,356$.

When the circuit produces no chemical decomposition out of the cells, no magnetic induction, and no mechanical or other external work, the whole of the energy developed by the chemical action in the cells takes the form of heat in different parts of the circuit. This fact is expressed by the following equation:—

$$Enz = M n \gamma = R \gamma^2; \dots \dots \dots (6.)$$

one of the consequences of which is the following:—

$$\gamma = \frac{M n}{R}; \dots \dots \dots (7.)$$

or, *the strength of the current is directly as the electro-motive force and inversely as the resistance of the circuit; being the celebrated principle known as "Ohm's Law."*

Another consequence shows the rapidity of chemical action in a given circuit, viz:—

$$nz = \frac{M n \gamma}{E} = \frac{M^2 n^2}{E R} \dots \dots \dots (8.)$$

397. Efficiency of Electro-magnetic Engines.—Equations 1, 2, 3, 4, and 5 of Article 396 are applicable to all electro-chemical circuits whatsoever. Equations 6, 7, and 8 are applicable only to an *idle battery*, as it may be called, in which all the energy is spent in producing heat in the materials of the circuit.

An electric circuit may move mechanism against resistance, and so perform mechanical work, in three ways.

I. By the mutual attractions and repulsions of currents, or of parts of one current. Currents in the same direction attract, and currents in contrary directions repel each other. This method has been used in philosophical apparatus only.

II. By the attractions and repulsions between currents and permanent magnets. A magnet placed with its south pole towards the

eye of the spectator attracts currents whose direction is that of right-handed revolution relatively to its axis, and repels those whose direction is that of left-handed revolution.

III. By the attractions and repulsions between temporary and permanent magnets. A conductor coiled round a soft iron bar, when a current is sent through it, magnetizes the bar in that direction which makes it attract the current, according to the principle stated above under head II.; when the current ceases the magnetism ceases; when the current is reversed the direction of the magnetism is reversed. Opposite poles of magnets attract, similar poles repel each other; so that by periodically reversing the temporary magnetism of a soft iron bar, it may be made to take a reciprocating motion towards and from a permanent magnet.

IV. By the mutual attractions of temporary magnets.

The efficiency of the engine in all those cases is governed by two principles: 1. *The performance of external work by an electric circuit produces a counteractive force, opposing the electromotive force, whose magnitude is equal to the external work performed in an unit of time divided by the strength of the current.*

Let U be the external work performed in an hour by the engine. This gives rise to a certain counteractive force, which causes the current to be of less strength than that which the battery produces when *idle*. Let γ be the strength of the current in the idle circuit, as given by equation 6 of Article 396; and γ' the strength when the work U is performed per hour. Then the counteractive force is,

$$U \div \gamma'$$

and the strength of current γ' is the same as if the electromotive force, instead of being Mn , were $Mn - \frac{U}{\gamma'}$; that is to say,

$$\gamma' = \frac{Mn}{R} - \frac{U}{\gamma'R} \dots \dots \dots (1).$$

This principle might be deduced as a consequence from the law of the conservation of energy; for multiplying equation 1 by $\gamma'R$, and transposing, we find,

$$U = Mn\gamma' - R\gamma'^2; \dots \dots \dots (2),$$

which expresses, *that the useful work of the engine is the excess of the whole energy developed in the battery $Mn\gamma'$, above the energy wasted in producing heat $R\gamma'^2$.*

2. A second principle is, *that the attractions and repulsions produced by a given circuit and apparatus arranged in a given way are proportional to the square of the strength of the current* (a law discovered by Mr. Joule); so that we may make

$$U = A \gamma'^2, \dots \dots \dots (3.)$$

where A is a factor depending on the apparatus used. Hence equation 2 becomes

$$A \gamma'^2 = M n \gamma' - R \gamma'^2 \dots \dots \dots (4.)$$

Divide by γ' and transpose; then

$$\gamma' = \frac{M n}{A + R}, \dots \dots \dots (5.)$$

Hence are deduced the following expressions:—

For the rapidity of the chemical action,

$$n z = \frac{M n \gamma'}{E} = \frac{M^2 n^2}{E (A + R)}, \dots \dots \dots (6.)$$

For the useful work,

$$U = \frac{A M^2 n^2}{(A + R)^2} \dots \dots \dots (7.)$$

For the efficiency of the engine,

$$\frac{U}{M n \gamma'} = \frac{A \gamma'}{M n} = \frac{A}{A + R} = \frac{\gamma - \gamma'}{\gamma}, \dots \dots \dots (8.)$$

From which it appears that the efficiency of the engine approximates towards unity as the factor A increases; but at the same time the absolute work performed diminishes without limit.

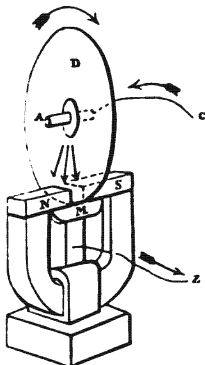

Fig. 174.

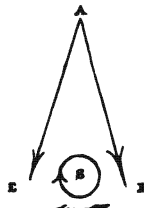

Fig. 175.

398. **Rotating Disc Engine.**—

This machine, the simplest of all electro-magnetic engines, but hitherto used in the lecture room only, is the result of a discovery of Arago's. In fig. 174, N and S are the north and south poles of a permanent magnet, so shaped as to approach very near to the two faces of a copper

disc D, near its lower edge; that disc turns on an axis A, whose bearings (not shown in the figure) must rest on insulating supports. The lower edge of the disc between the poles of the magnet dips

into a cup M, containing mercury. C and Z are conducting wires, connecting respectively the axis of the disc and the mercury in the cup with the *electrodes* of a galvanic battery. By the arrangement shown in the figure, an electric current is made to pass from the positive electrode to the axis of the disc; thence through the disc to the mercury, and thence to the negative electrode of the battery. The action of the poles of the magnet on the disc is shown by the diagram, fig. 175. S is the magnet, with the south pole exposed to view; the arrow head on the circle shows the direction of the revolving current to which the magnet is equivalent. A B and A E are two portions of the current in the disc, from the axis to the mercury. According to the principle that currents in the same direction attract each other, and currents in opposite directions repel each other, the magnet attracts A B and repels A E, and so keeps up a continuous rotation of the disc in the direction B E. The direction of rotation can be reversed by reversing the current; that is, by connecting A with Z and M with C.

399. **Rotating Bar Engine.**—This machine, the invention of Mr. Webster, is shown in fig. 176. N S, N S, are two semicircular permanent magnets fixed within a frame of brass or other diamagnetic material, and having two gaps between their pairs of contiguous poles, which are similar, as indicated by the letters. M is a mercury-cup of non-conducting material on a pedestal; it is divided into two parts by a diametral non-conducting partition, in the plane of the permanent magnets, as shown in fig. 177. In the centre of the cup stands a

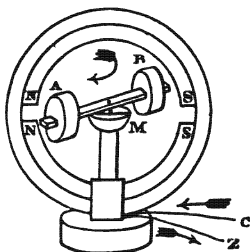

Fig. 176.



Fig. 177.

pivot, on which rotates the horizontal soft iron bar A B; the two arms of that bar are encircled by the two portions of a long coil of conducting wire. The two ends of that coil dip into the two halves of the mercury cup, which halves are connected with the electrodes of a battery by the wires C Z. The ends of the soft iron bar pass between the poles of the permanent magnet, so as to come very near them, but not to touch them.

To produce rotation in the direction indicated by the arrow, the coil round the bar A B is so arranged that when the end A is moving from S S to N N, and the end B from N N to S S, A is a south pole, and B a north pole. Then $\left. \begin{matrix} A \\ B \end{matrix} \right\}$ is $\left\{ \begin{matrix} \text{repelled} \\ \text{attracted} \end{matrix} \right\}$ by S S, and $\left\{ \begin{matrix} \text{attracted} \\ \text{repelled} \end{matrix} \right\}$ by N N. At the instant that the ends of the bar

pass the poles of the permanent magnets, the ends of the coil pass over the diametral partition into the opposite halves of the mercury cup; the current through the coil is reversed, and reverses the magnetism of A B, and the attractions and repulsions between its poles and those of the permanent magnets; and so the rotation is kept up. To reverse the rotation, the connections between the halves of the mercury-cup and the electrode are reversed.

400. The **Plunger Engine**, invented by Mr. Froment, and made by Mr. Bourbouze, is represented in figures 178, 179, and 180.

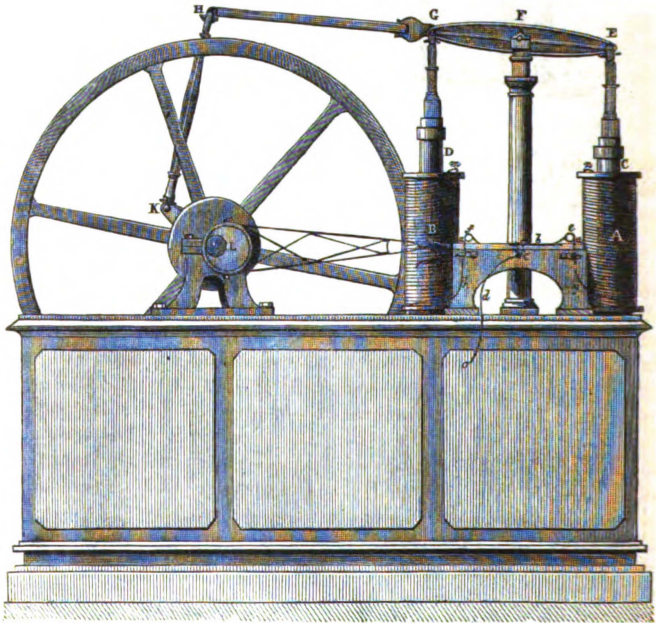

Fig. 178.

It is now used to a considerable extent in France, for driving small machines in places where it would be inconvenient to have a steam engine with its furnace and boiler. It bears some analogy in its form and arrangement to a steam engine with four cylinders, pistons, slide valves, beam, crank, and eccentric.

Fig. 178 is a side elevation; fig. 179, an end view, showing two of the cylinders; fig. 180, a plan of the four cylinders.

A A, B B, are four soft iron hollow cylinders, enveloped in coils of conducting wire; C C, D D, are horse-shoe magnets, each of

which is so shaped that its ends form a pair of cylindrical plungers, moving up and down in the hollow cylinders, with just freedom

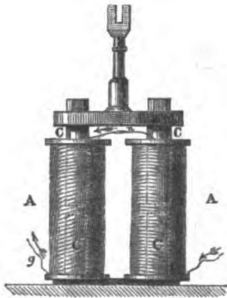

Fig. 179.

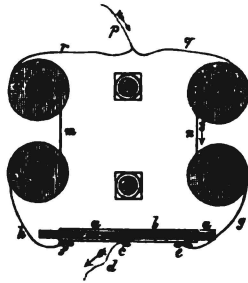

Fig. 180.

enough to prevent contact; H G F E is the beam, from which the magnetic plungers are hung; F its centre; H K the connecting rod; K L the crank; L the shaft and eccentric. The shaft carries a fly wheel.

a b a is a slide moved by the eccentric, the parts *a a* being of ivory, and *b* of metal; *c d o*, conducting wire from the metallic part *b* of the slide to the negative electrode; *p*, conducting wire from positive electrode; *q n*, conductors from *p* to the coil round A A; *r m*, conductors from *p* to the coil round B B; *g*, conductor from the opposite end of the coil round A A, terminating in the spring *e*, which presses on the slide *a b a*; *h*, conductor from the coil round B, terminating in the spring *f*, which presses on the slide *a b a*. The reciprocating motion of the slide establishes the electric circuit through the coils round A A, and round B B, alternately, and thus magnetizes alternately those two pairs of hollow cylinders, which attract alternately the two pairs of magnetic plungers, C C, D D, and give a reciprocating motion to the beam, and a rotatory motion to the shaft.

APPENDIX.

No. 1.—PART I., CHAPTER IV.

The **Horse-Power Engine** is one in which a horse, while pressing with his shoulders against a collar attached to the frame of the engine, drives backwards with his feet, by the action of walking, an endless travelling roadway, from which motion is communicated to machinery. The action of the horse is exactly similar to that of a horse drawing a vehicle; and his tractive force and daily work are probably the same.

This kind of engine was invented, and first constructed and tried for the purpose of traction on Railways, at a speed exceeding the most efficient speed of the horse, by Mr. H. Brandreth of Liverpool, in 1829. (See *Wood On Railroads*, edition of 1831, page 304). Its use as a railway locomotive engine was immediately abandoned; but it is now employed with great convenience and advantage in America, for driving portable saw-mills and farming machines; and is thus described by Mr. Whitworth, in his Report on the New York Industrial Exhibition of 1853, chapter v., article 26:—"It . . . consists of a stout frame, supporting a railway " about 7 feet long, on which run the rollers of an endless travelling plat- " form. The axles of the rollers are of iron, $\frac{5}{8}$ inch diameter, stretching " across the rails, and are connected together by a series of links, each about " 12 inches long, so as to form an endless chain, which passes over a fixed " segment at one end, and the chain-wheels at the other. The travelling " platform is made by planks of wood, about 12 inches broad and $1\frac{1}{2}$ " inches thick, fastened transversely to the endless chain. It is inclined " at an angle of about 7° to the horizontal line, and the horse being " placed on the platform, pushes it backwards from under him, which causes " the chain-wheels at the end of the frame to revolve; and the motion " thus obtained is conveyed to the circular saw, or other machine re- " quired to be driven. Some horse-power machines are made to admit " two horses abreast."

No. 2.—ARTICLES 292, 293.

Efficiency of Propellers.—This subject cannot be discussed except in a treatise on the forms of ships. In the present work, all that can be done is to give a brief summary of the leading principles.

The *efficiency* of a propeller is the ratio of the work performed in a given time in driving the ship, to the work performed by the engine in moving the propeller. (A pair of paddles is to be held to constitute one propeller). The difference between those two quantities is the energy exerted by the propeller in giving motion to the water.

Let R_1 represent at once the resistance of the water to the motion of the ship, and the pressure exerted directly backwards by the propeller against the water in lbs., these two forces being equal when the velocity of the ship is uniform.

Let V be the velocity of the ship in feet per second; g , the accelerating effect of gravity in a second = 32.2; w , the weight of a cubic foot of water = from 62.4 to 64 lbs.; A , a multiplier, which depends mainly on the dimensions and figure of the ship, and which, though not absolutely constant at different velocities, is nearly constant throughout the ordinary variations of speed of one given steamer; then the resistance of the ship may be thus expressed:—

$$R_1 = A w \frac{V^2}{2g} \dots\dots\dots(1.)$$

Let $V + S$ be the backward velocity of the propeller, *relatively to the ship*, in feet per second; that is—

$V + S$ = revolutions per second \times circumference of paddle through centres of action of floats (which centres are at the middle of feathering floats, and about $\frac{1}{4}$ of the breadth from the outer edges of fixed floats).

$V + S$ = revolutions per second \times pitch of screw. S is called the "*slip*" of the propeller, and its value for paddles ranges from $\frac{1}{3}$ V to $\frac{1}{2}$ V , and for screws from $\frac{1}{10}$ V to V .

Let $c S$ be the velocity of the current driven directly backwards by the propeller, whether paddle, screw, or jet, or of any other kind.

Let a be the sectional area of the space in which the propeller acts; that is, the area of one pair of paddle-floats, or of the *screw-disc*, or of the jet, as the case may be; $k a$, the sectional area of the current driven backwards. Then the force exerted directly backwards by the propeller against the water is—

$$R_2 = \frac{c k a w V S}{g}, \dots\dots\dots(2.)$$

Equating the expressions 1 and 2, we find

$$\frac{S}{V} = \frac{A}{2 c k a} \dots\dots\dots(3.)$$

The work performed per second in propelling the ship is $R_1 V$; the work performed by the engine in driving the propeller, $R_2 (V + S)$. It appears, then, that the *efficiency of the propeller* is—

$$\frac{V}{V + S} = 1 \div \left(1 + \frac{A}{2 c k a} \right) \dots\dots\dots(4.)$$

The coefficient, $c k$, can only be found empirically. For paddles, it depends on the figure, number, arrangement, and manner of moving of the floats; for screws, on the number, arrangement, breadth, form, pitch, and depth of immersion of the blades, and also on the figure of the vessel, according to laws which have not yet been fully ascertained. The following are some of its values:—

For feathering paddles with Elder's plate iron floats, about 1.4

For various different screws, from 1.0 to 1.6.

To exemplify the influence of the efficiency of the propeller upon the resultant efficiency of the whole combination of furnace, boiler, cylinder, mechanism, and propeller, the case may be referred to, which has been

taken as an example in Article 293, and as Example I in Article 289. In the articles cited it is shown, that
 the efficiency of the furnace and boiler was,..... 0.542 ;
 the efficiency of the steam,..... 0.123 ;
 the efficiency of the mechanism, $\frac{10.63}{18.15}$ (see page 427),..... 0.81 ;
 and the efficiency of the propeller (a pair of plate iron feather- }
 ing paddles) was found to be } 0.78 ;
 consequently,
 resultant efficiency of mechanism and propeller, $0.78 \times 0.81 = 0.63$;
 resultant efficiency of combination, $0.542 \times 0.123 \times 0.63 = 0.042$.

No. 3.—ARTICLES 297, 298.

Superheated Steam Engines.—According to recent experiments on the large scale, by Mr. Penn, upon marine engines, which he lately fitted with superheating apparatus, about 20 per cent. of fuel was saved by superheating steam, at a pressure of 20 lb. per square inch above the atmosphere, to the extent of 100° Fahrenheit. Mr. Penn's paper will probably appear in the Transactions of the Institution of Mechanical Engineers for September, 1859.

No. 4.—ARTICLE 337.

The **Counter and Indicator** should have been included amongst the appendages of steam engines. The indicator has been fully explained in previous parts of this work. The counter (invented by Watt, and improved by others) records on dial-plates the number of strokes made by the engine.

No. 5.—ARTICLE 344.

Equilibrium-Piston for Slide Valve.—Mr. Bourne balances partially the pressure on the back of the slide-valve by connecting it, through a link, to a piston in a very short cylinder at the back of the valve-chest, the area of the piston being a little less than that of the valve.

No. 6.—ADDENDA TO TABLE II.

Values of $\gamma = K_p \div K_v$. Air, 1.408; Oxygen, 1.4; Hydrogen 1.413; Nitrogen, 1.409; Steam-gas, 1.304.* Ice, D. = 57.5; S. G. = 0.92; C = 0.504; K = 389.

No. 7.—DENSITY OF STEAM.

Experiments by Mr. Fairbairn and Mr. Tate compared with theory:—

Temp. Fahr.	Ratio of volume of steam to volume of water.		Diff.	Temp. Fahr.	Ratio of volume of steam to volume of water.		Diff.
	By theory.	By exper.			By theory.	By exper.	
244°	936	896	40	268°	635	633	2
245	920	890	30	270	616	604	12
257	756	751	5	283	506	490	16
262	698	684	14				

The fact that all the results of theory exceed those of experiment may arise from a difference in the value assumed for the volume of water. The theoretical results are based on the *minimum* volume of water, at 39°·1 F.

No. 8.—FEED APPARATUS.

A recent invention for this purpose is a jet pump driven by a steam jet.

TABLES.

I.—TABLE OF HEIGHTS DUE TO VELOCITIES.

EXPLANATION OF SYMBOLS.

v = Velocity in feet per second.

h = Height in feet = $v^2 \div 64 \cdot 4$.

This table is exact for latitude $54^\circ\frac{1}{2}$, and near enough to exactness for practical purposes in all parts of the earth's surface.

v	h	v	h	v	h
1	01553	27	11320	54	45279
2	06211	28	12174	56	48695
3	13975	29	13059	58	52235
4	24844	30	13975	60	55900
5	38819	31	14922	62	59688
6	55900	32	15900	64	63601
7	76086	32.2	16100	64.4	64400
8	99377	33	16910	66	67639
9	12577	34	17950	68	71800
10	15528	35	19021	70	76086
11	18789	36	20124	72	80496
12	22360	37	21257	74	85029
13	26241	38	22422	76	89688
14	30434	39	23618	78	94471
15	34937	40	24844	80	99377
16	39751	41	26102	82	10441
17	44875	42	27391	84	10956
18	50310	43	28711	86	11484
19	56055	44	30062	88	12025
20	62111	45	31444	90	12577
21	68477	46	32857	92	13143
22	75153	47	34301	94	13720
23	82141	48	35776	96	14310
24	89439	49	37282	98	14913
25	97048	50	38819	100	15528
26	10497	52	41987		

II.

TABLE OF WEIGHT, VOLUME, ELASTICITY, EXPANSION, AND SPECIFIC HEAT.

EXPLANATION OF SYMBOLS.

P_0 —Mean pressure of the atmosphere, in lbs. avoirdupois on the square foot, = 2116.4.

D_0 —Density, or weight of one cubic foot of the substance, in lbs. avoirdupois, under the pressure of one atmosphere, and at the temperature of melting ice, except for water, for which the temperature is 39° 1 Fahrenheit.

V_0 —Volume in cubic feet of one pound avoirdupois of the substance, at the before-mentioned pressure and temperature.

S.G.—Specific gravity, that of water being taken as unity.

E.—Expansion of unity of volume for fluids, or unity of length for solids, at the temperature of melting ice, in rising to the temperature of water boiling under the pressure of one atmosphere.

C.—Specific heat, that of water being taken as unity.

K.—Specific heat in foot-pounds per degree of Fahrenheit. For gases, specific heats at constant volume and constant pressure are distinguished by the symbols C_v , C_p , or K_v , K_p , as the case may be.

GASES.	D_0	V_0	$P_0 V_0$	E	C_v	K_v	C_p	K_p
Air,.....	0.080728	12.387	26214	.365	0.169	130.3	0.238	183.45
Oxygen,.....	0.089256	11.204	23710	.367	0.156	120.2	0.218	168.3
Hydrogen,.....	0.005592	178.83	378819	.366	2.410	1860.6	3.405	2628.7
Steam,.....	0.05022*	19.913*	42141*	.365*	0.365*	281.3*	0.475	366.7
Æther Vapour,.....	0.2093*	4.777*	10110*	0.481	371.3
Bisulphuret of Carbon Vapour, } Carbonic Acid, ideal,..... } Do. actual,.....	0.2137* 0.12259*	4.679* 8.157*	9902* 17264*365*	0.1575 ...	121.6 ...
Olefiant Gas,.....	0.0795	12.58	0.217	167.
Nitrogen,.....	0.078411	12.753	26990	...	0.173	133.6	0.244	188.4
Vapour of Mercury,	0.563*	1.7762*	3759*

* This mark is affixed to results computed for the ideal condition of perfect gas.

LIQUIDS.					
	D.	S.G.	E.	C.	K.
Water, pure (at 39°·1 Fahrenheit),.....	62·425	1·000	0·04775	1·000	772·0
„ sea, ordinary,	64·05	1·026	0·05
Alcohol, pure,	49·38	0·791	0·1112
„ proof spirit,	57·18	0·916
Æther,	44·70	0·716	...	0·517	399·1
Mercury,	848·75	13·596	0·018153	0·033	25·5
Naphtha,	52·94	0·848
Oil, linseed,	58·68	0·940	0·08
„ olive,	57·12	0·915	0·08
„ whale,	57·62	0·923
„ of turpentine,	54·31	0·870	0·07
Petroleum,	54·81	0·878

SOLID METALS.					
Brass,	487 to 533	7·8 to 8·5	·00216
Bronze,	524	8·4	·00181
Copper,	537 to 556	8·6 to 8·9	·00184	·0951	73·3
Gold,	1186 to 1224	19 to 19·6	·0015	·0298	23·0
Iron, cast,	444	7·11	·0011
Iron, wrought,	480	7·69	·0012	·1138	87·8
Lead,	712	11·4	·0029	·0293	22·6
Platinum,	1311 to 1373	21 to 22	·0009	·0314	24·2
Silver,	655	10·5	·002	·557	43·0
Steel,	490	7·85	·0012
Tin,	462	7·4	·0022	·0514	39·7
Zinc,	436	7·2	·00294	·0927	71·6

WEIGHT, EXPANSION, AND SPECIFIC HEAT.

III.

TABLE OF THE ELASTICITY OF A PERFECT GAS.

EXPLANATION OF SYMBOLS.

T.—Temperature, measured from the ordinary zero.

t.—Absolute temperature, measured from the absolute zero.

P.—Pressure of a perfect gas in pounds avoirdupois on the square foot.

V.—Volume of one pound avoirdupois in cubic feet.

PV.—Product of these quantities at any given temperature.

P_0V_0 —Value of that product for the temperature of melting ice.

Centigrade.		Fahrenheit.		$\frac{PV}{P_0V_0}$
T	<i>t</i>	T	<i>t</i>	
-30°	244°	-22°	439·2	0·8905
-25	249	-13	448·2	0·9088
-20	254	- 4	457·2	0·9270
-15	259	+ 5	466·2	0·9453
-10	264	14	475·2	0·9635
- 5	269	23	484·2	0·9818
0	274	32	493·2	1·0000
+ 5	279	41	502·2	1·0182
10	284	50	511·2	1·0365
15	289	59	520·2	1·0547
20	294	68	529·2	1·0730
25	299	77	538·2	1·0912
30	304	86	547·2	1·1095
35	309	95	556·2	1·1277
40	314	104	565·2	1·1460
45	319	113	574·2	1·1643
50	324	122	583·2	1·1825
55	329	131	592·2	1·2007
60	334	140	601·2	1·2190
65	339	149	610·2	1·2373
70	344	158	619·2	1·2555
75	349	167	628·2	1·2738
80	354	176	637·2	1·2920
85	359	185	646·2	1·3103
90	364	194	655·2	1·3285

Centigrada.		Fahrenheit.		PV
T	t	T	t	P_0P_0
95°	369°	203°	664°	1'3468
100	374	212	673°	1'3650
105	379	221	682°	1'3832
110	384	230	691°	1'4015
115	389	239	700°	1'4197
120	394	248	709°	1'4380
125	399	257	718°	1'4562
130	404	266	727°	1'4744
135	409	275	736°	1'4927
140	414	284	745°	1'5109
145	419	293	754°	1'5292
150	424	302	763°	1'5474
155	429	311	772°	1'5657
160	434	320	781°	1'5839
165	439	329	790°	1'6022
170	444	338	799°	1'6204
175	449	347	808°	1'6387
180	454	356	817°	1'6569
185	459	365	826°	1'6752
190	464	374	835°	1'6934
195	469	383	844°	1'7117
200	474	392	853°	1'7299
205	479	401	862°	1'7481
210	484	410	871°	1'7664
215	489	419	880°	1'7846
220	494	428	889°	1'8029
230	504	446	907°	1'8394
240	514	464	925°	1'8759
250	524	482	943°	1'9124
260	534	500	961°	1'9489
270	544	518	979°	1'9854
280	554	536	997°	2'0219
290	564	554	1015°	2'0584
300	574	572	1033°	2'0949
310	584	590	1051°	2'1314
320	594	608	1069°	2'1679
330	604	626	1087°	2'2044
340	614	644	1005°	2'2409
350	624	662	1123°	2'2774
360	634	680	1141°	2'3139
370	644	698	1159°	2'3504
380	654	716	1177°	2'3869

Centigrade.		Fahrenheit.		$\frac{PV}{P_0V_0}$
T	t	T	t	
390°	664°	734°	1195°2	2·4234
400	674	752	1213°2	2·4599
410	684	770	1231°2	2·4964
420	694	788	1249°2	2·5329
430	704	806	1267°2	2·5693
440	714	824	1285°2	2·6058
450	724	842	1303°2	2·6423
460	734	860	1321°2	2·6788
470	744	878	1339°2	2·7153
480	754	896	1357°2	2·7518
490	764	914	1375°2	2·7883
500	774	932	1393°2	2·8248
520	794	968	1429°2	2·8978
540	814	1004	1465°2	2·9708
560	834	1040	1501°2	3·0438
580	854	1076	1537°2	3·1168
600	874	1112	1573°2	3·1898
620	894	1148	1609°2	3·2628
640	914	1184	1645°2	3·3358
660	934	1220	1681°2	3·4088
680	954	1256	1717°2	3·4818
700	974	1292	1753°2	3·5547
720	994	1328	1789°2	3·6277
740	1014	1364	1825°2	3·7007
760	1034	1400	1861°2	3·7737
780	1054	1436	1897°2	3·8467
800	1074	1472	1933°2	3·9197
820	1094	1508	1969°2	3·9927
840	1114	1544	2005°2	4·0657
860	1134	1580	2041°2	4·1387
880	1154	1616	2077°2	4·2117
900	1174	1652	2113°2	4·2847
920	1194	1688	2149°2	4·3577
940	1214	1724	2185°2	4·4307
960	1234	1760	2221°2	4·5036
980	1254	1796	2257°2	4·5766
1000	1274	1832	2293°2	4·6496

IV.

TABLE OF PROPERTIES OF STEAM OF MAXIMUM DENSITY BY THE CUBIC FOOT.

T.	P.	Log. P.	Δ log. P.	L.	Log. L.	Δ log. L.	D.	Log. D.	Δ log. D
32°	12·27	1·0887		248·6	2·3955		0·000295	4·4698	
			0·1572			0·1464			0·1489
41	17·62	1·2459		348·3	2·5419		0·000416	4·6187	
			0·1507			0·1402			0·1427
50	24·92	1·3966		481·0	2·6821		0·000577	4·7614	
			0·1446			0·1343			0·1369
59	34·77	1·5412		655·2	2·8164		0·000791	4·8983	
			0·1388			0·1287			0·1311
68	47·87	1·6800		881·3	2·9451		0·001070	3·0294	
			0·1333			0·1234			0·1261
77	65·06	1·8133		1171	3·0685		0·001431	3·1555	
			0·1282			0·1185			0·1209
86	87·40	1·9415		1538	3·1870		0·001890	3·2764	
			0·1233			0·1138			0·1164
95	116·1	2·0648		1999	3·3008		0·002471	3·3928	
			0·1187			0·1093			0·1120
104	152·6	2·1835		2571	3·4101		0·003197	3·5048	
			0·1145			0·1053			0·1079
113	198·6	2·2980		3277	3·5154		0·004099	3·6127	
			0·1102			0·1012			0·1039
122	256·0	2·4082		4136	3·6166		0·005207	3·7166	
			0·1064			0·0976			0·1003
131	327·0	2·5146		5178	3·7142		0·006560	3·8169	
			0·1027			0·0940			0·0966

T.	P.	Log. P.	Δ log. P.	L.	Log L.	Δ log. L.	D.	Log. D.	Δ log. D.
140	414'3	2'6173		6430	3'8082		0'008194	3'9135	
			0'0992			0'0906			0'0933
149	520'6	2'7165		7921	3'8988		0'01016	2'0068	
			0'0958			0'0874			0'0902
158	649'1	2'8123		9687	3'9862		0'01250	2'0970	
			0'0926			0'0843			0'0870
167	803'3	2'9049		11760	4'0705		0'01528	2'1840	
			0'0897			0'0816			0'0844
176	987'6	2'9946		14200	4'1521		0'01855	2'2684	
			0'0867			0'0787			0'0815
185	1206	3'0813		17010	4'2308		0'02238	2'3499	
			0'0840			0'0762			0'0790
194	1463	3'1653		20280	4'3070		0'02685	2'4289	
			0'0814			0'0736			0'0764
203	1765	3'2467		24020	4'3806		0'03201	2'5053	
			0'0789			0'0713			0'0741
212	2116'4	3'3256		28310	4'4519		0'03797	2'5794	
			0'0765			0'0690			0'0719
221	2524	3'4021		33180	4'5209		0'04480	2'6513	
			0'0741			0'0668			0'0697
230	2994	3'4762		38700	4'5877		0'05260	2'7210	
			0'0721			0'0648			0'0678
239	3534	3'5483		44930	4'6525		0'06149	2'7888	
			0'0700			0'0628			0'0657
248	4152	3'6183		51920	4'7153		0'07153	2'8545	
			0'0678			0'0608			0'0638

T.	P.	Log. P.	Δ log. P.	L.	Log. L.	Δ log. L.	D.	Log. D.	Δ log. D.
257	4854	3·6861		59720	4·7761		0·08285	2·9183	
			0·0661			0·0591			0·0621
266	5652	3·7522		68420	4·8352		0·09559	2·9804	
			0·0641			0·0572			0·0603
275	6551	3·8163		78050	4·8924		0·1098	1·0407	
			0·0624			0·0557			0·0586
284	7563	3·8787		88740	4·9481		0·1257	1·0993	
			0·0607			0·0540			0·0572
293	8698	3·9394		100500	5·0021		0·1434	1·1565	
			0·0591			0·0525			0·0556
302	9966	3·9985		113400	5·0546		0·1630	1·2121	
			0·0575			0·0510			0·0542
^s 0 311	11380	4·0560		127500	5·1056		0·1846	1·2663	
			0·0560			0·0496			0·0526
320	12940	4·1120		143000	5·1552		0·2084	1·3189	
			0·0546			0·0483			0·0515
329	14680	4·1666		159800	5·2035		0·2346	1·3704	
			0·0531			0·0469			0·0503
338	16580	4·2197		178000	5·2504		0·2635	1·4207	
			0·0519			0·0457			0·0489
347	18690	4·2716		197700	5·2961		0·2948	1·4696	
			0·0505			0·0444			0·0477
356	20990	4·3221		219000	5·3405		0·3291	1·5173	
			0·0493			0·0433			0·0466
365	23520	4·3714		242000	5·3838		0·3664	1·5639	
			0·0480			0·0421			0·0455

T.	P.	Log. P.	Δ log. P.	L.	Log. L.	Δ log. L.	D.	Log. D.	Δ log. D.
374	26270	4.4194		266600	5.4259		0.4068	1.6094	
			0.0470			0.0411			0.0445
383	29270	4.4664		293100	5.4670		0.4507	1.6539	
			0.0458			0.0401			0.0435
392	32520	4.5122		321400	5.5071		0.4982	1.6974	
			0.0447			0.0390			0.0426
401	36050	4.5569		351600	5.5461		0.5495	1.7400	
			0.0438			0.0381			0.0416
410	39870	4.6007		383900	5.5842		0.6048	1.7816	
			0.0426			0.0371			0.0407
419	43990	4.6433		418100	5.6213		0.6642	1.8223	
			0.0418			0.0362			0.0397
428	48430	4.6851		454500	5.6575		0.7278	1.8620	

EXPLANATION OF SYMBOLS.

T.—Temperature on Fahrenheit's scale.

P.—Pressure in pounds avoirdupois per square foot.

L.—Latent heat of evaporation per cubic foot of vapour in foot-pounds of energy. To reduce this to units of heat, divide by 772 (Joule's equivalent).

D.—Probable weight of a cubic foot of vapour in pounds avoirdupois.

V.

TABLE OF PROPERTIES OF VAPOUR OF ÆTHER BY THE CUBIC FOOT.

T. Fahr.	P.	Log. P.	Δ log. P.	L.	Log. L.	Δ log. L.	D.	Log. D.	Δ log. D.
32°	511	2·7085		6522	3·8144		0·05056	2·7038	
			0·1944			0·1751			0·1788
50	800	2·9029		9761	3·9895		0·07631	2·8826	
			0·1796			0·1610			0·1645
68	1209	3·0825		14142	4·1505		0·11115	1·0471	
			0·1664			0·1486			0·1520
86	1774	3·2489		19991	4·2991		0·1581	1·1991	
			0·1547			0·1375			0·1406
104	2533	3·4036		27328	4·4366		0·2186	1·3397	
			0·1441			0·1275			0·1305
122	3529	3·5477		36652	4·5641		0·2953	1·4702	
			0·1347			0·1187			0·1214
140	4813	3·6824		48173	4·6828		0·3905	1·5916	
			0·1261			0·1106			0·1133
158	6434	3·8085		62145	4·7934		0·5069	1·7049	
			0·1179			0·1030			0·1055
176	8441	3·9264		78777	4·8964		0·6463	1·8104	
			0·1111			0·0966			0·0990
194	10902	4·0375		98401	4·9930		0·8117	1·9094	
			0·1045			0·0904			0·0927
212	13868	4·1420		121170	5·0834		1·0048	0·0021	
95	2116·4	3·3256		23290	4·3672		0·1856	1·2686	

ÆTHER.

563

VI.

TABLE OF PROPERTIES OF STEAM OF MAXIMUM DENSITY BY THE POUND AVOIRDUPOIS.

STEAM BY THE POUND.

T.	P.	Log. P.	Δ log. P.	p.	V.	Log. V.	$-\Delta$ log. V.	U.	Δ U.	H.	h.
32°	12·27	1·0887		0·085	3390	3·5302		0		842872	0
			0·1572				0·1489		15200		
41	17·62	1·2459		0·122	2406	3·3813		15200		844988	6948
			0·1507				0·1427		14850		
50	24·92	1·3966		0·173	1732	3·2386		30050		847103	13896
			0·1446				0·1369		14500		
59	34·77	1·5412		0·241	1264	3·1017		44550		849218	20844
			0·1388				0·1311		14160		
68	47·87	1·6800		0·333	934·6	2·9706		58710		851333	27792
			0·1333				0·1261		13860		
77	65·06	1·8133		0·452	699·0	2·8445		72570		853448	34740
			0·1282				0·1209		13530		
86	87·40	1·9415		0·607	529·2	2·7236		86100		855563	41702
			0·1233				0·1164		13240		
95	116·1	2·0648		0·806	404·8	2·6072		99340		857678	48650
			0·1187				0·1120		12950		
104	152·6	2·1835		1·06	312·8	2·4952		112290		859793	55612
			0·1145				0·1079		12660		
113	198·6	2·2980		1·38	244·0	2·3873		124950		861908	62560
			0·1102				0·1039		12400		
122	256·0	2·4082		1·78	192·0	2·2834		137350		864024	69522
			0·1064				0·1003		12120		
131	327·0	2·5146		2·27	152·4	2·1831		149470		866139	76484
			0·1027				0·0966		11870		

T.	F.	Log. P.	Δ log. P.	p.	V.	Log. V.	$-\Delta$ log. V.	U.	Δ U.	H.	z.
140°	414.3	2.6173		2.88	122.0	2.0865		161340		868254	83459
			0.0992				0.0933		11620		
149	520.6	2.7165		3.62	98.45	1.9932		172960		870369	90435
			0.0958				0.0900		11380		
158	649.1	2.8123		4.51	80.02	1.9032		184340		872484	97411
			0.0926				0.0872		11150		
167	803.3	2.9049		5.58	65.47	1.8160		195490		874600	104387
			0.0897				0.0843		10920		
176	987.6	2.9946		6.86	53.92	1.7317		206410		876715	111363
			0.0867				0.0814		10700		
185	1206	3.0813		8.38	44.70	1.6503		217110		878830	118353
			0.0840				0.0791		10490		
194	1463	3.1653		10.16	37.26	1.5712		227600		880945	125357
			0.0814				0.0762		10270		
203	1765	3.2467		12.26	31.26	1.4950		237870		883060	132360
			0.0789				0.0741		10080		
212	2116.4	3.3256		14.70	26.36	1.4209		247950		885175	139363
			0.0765				0.0718		9860		
221	2524	3.4021		17.53	22.34	1.3491		257810		887290	146380
			0.0741				0.0697		9670		
230	2994	3.4762		20.80	19.03	1.2794		267480		889405	153412
			0.0721				0.0677		9500		
239	3534	3.5483		24.54	16.28	1.2117		276980		891520	160429
			0.0700				0.0656		9310		
248	4152	3.6183		28.83	14.00	1.1461		286290		893635	167460
			0.0678				0.0637		9120		

T.	P.	Log. P.	Δ log. P.	p.	V.	Log. V.	$-\Delta$ log. V.	U.	Δ U.	H.	A.
257°	4854	3·6861	0·0661	33·71	12·09	1·0824	0·0620	295410	8960	895751	174505
266	5652	3·7522	0·0641	39·25	10·48	1·0204	0·0602	304370	8790	897866	181564
275	6551	3·8163	0·0624	45·49	9·124	0·9602	0·0586	313160	8620	899981	188637
284	7563	3·8787	0·0607	52·52	7·973	0·9016	0·0570	321780	8450	902096	195711
293	8698	3·9394	0·0591	60·40	6·992	0·8446	0·0555	330230	8290	904211	202798
302	9966	3·9985	0·0575	69·21	6·153	0·7891	0·0541	338520	8150	906327	209885
311	11380	4·0560	0·0560	79·03	5·433	0·7350	0·0523	346670	8000	908442	216986
320	12940	4·1120	0·0546	89·86	4·816	0·6827	0·0513	354670	7840	910557	224087
329	14680	4·1666	0·0531	101·9	4·280	0·6314	0·0500	362510	7710	912672	231216
338	16580	4·2197	0·0519	115·1	3·814	0·5814	0·0486	370220	7550	914787	238358
347	18690	4·2716	0·0505	129·8	3·410	0·5328	0·0475	377770	7430	916902	245501
356	20990	4·3221	0·0493	145·8	3·057	0·4853	0·0463	385200	7290	919017	252658
365	23520	4·3714	0·0480	163·3	2·748	0·4390	0·0452	392490	7160	921132	259829

T.	P.	Log. P.	Δ log. P.	p .	V.	Log. V.	$-\Delta$ log. V.	U.	Δ U.	H.	h .
374°	26270	4·4194		182·4	2·476	0·3938		399650		923247	267013
			0·0470				0·0443		7020		
383	29270	4·4664		203·3	2·236	0·3495		406670		925362	274198
			0·0458				0·0431		6910		
392	32520	4·5122		225·9	2·025	0·3064		413580		927478	281394
			0·0447				0·0421		6780		
401	36050	4·5569		250·3	1·838	0·2643		420360		929593	288634
			0·0438				0·0411		6660		
410	39870	4·6007		276·9	1·672	0·2232		427020		931708	295874
			0·0426				0·0399		6530		
419	43990	4·6433		305·5	1·525	0·1833		433550		933823	303128
			0·0418				0·0393		6430		
428	48430	4·6851		336·3	1·393	0·1440		439980		935939	310381

EXPLANATION OF SYMBOLS.

- T.—Temperature on Fahrenheit's scale, or *boiling point*.
- P.—Pressure in pounds avoirdupois on the square foot.
- p .—Pressure in pounds on the square inch : $\text{Log. } p = \text{Log. } P - 2\cdot1584$.
- V.—Volume of one pound avoirdupois of steam in cubic feet.
- U.—Work in foot-pounds per pound by one pound of steam, admitted into the cylinder at the temperature T° , and expanded *without liquefaction* until its temperature falls to 32° Fahr.
- H.—*Total heat*, in foot-pounds of energy, required to raise one pound of water from 32° to T° , and evaporate it at T° .
- h .—Heat, in foot-pounds of energy, required to raise the temperature of one pound of water from 32° to T° .
- $H - h = \text{Latent heat}$ of one pound of steam at T° .

VII.—UNJACKETED CYLINDERS.

TABLE OF APPROXIMATE RATIOS.

r	$\frac{1}{r}$	$\frac{rP_m}{P_1}$	$\frac{P_1}{rP_m}$	$\frac{P_1}{P_m}$	$\frac{P_m}{P_1}$
20	·05	3·55	·282	5·64	·177
13 $\frac{1}{3}$	·075	3·25	·308	4·11	·244
10	·1	3·03	·330	3·30	·303
8	·125	2·85	·350	2·80	·356
6 $\frac{2}{3}$	·15	2·71	·369	2·46	·407
5	·2	2·48	·404	2·02	·496
4	·25	2·29	·437	1·75	·572
3 $\frac{1}{3}$	·3	2·13	·471	1·57	·639
2 $\frac{2}{3}$	·35	1·99	·503	1·43	·697
2 $\frac{1}{3}$	·4	1·87	·534	1·33	·748
2 $\frac{1}{4}$	·45	1·77	·567	1·26	·797
2	·5	1·67	·600	1·20	·833
1 $\frac{6}{11}$	·55	1·58	·635	1·15	·869
1 $\frac{3}{5}$	·6	1·49	·669	1·11	·894
1 $\frac{1}{3}$	·65	1·42	·703	1·08	·923
1 $\frac{2}{7}$	·7	1·35	·740	1·06	·945
1 $\frac{1}{3}$	·75	1·28	·781	1·04	·960
1 $\frac{1}{4}$	·8	1·22	·821	1·03	·976
1 $\frac{3}{17}$	·85	1·16	·861	1·013	·986
1 $\frac{1}{2}$	·9	1·11	·903	1·003	·997

VIII.—JACKETED CYLINDERS.

TABLE OF APPROXIMATE RATIOS.

r	$\frac{1}{r}$	$\frac{rP_m}{P_1}$	$\frac{P_1}{rP_m}$	$\frac{P_1}{P_m}$	$\frac{P_m}{P_1}$
20	·05	3·73	·268	5·36	·186
13 $\frac{1}{3}$	·075	3·39	·295	3·93	·254
10	·1	3·14	·318	3·18	·314
8	·125	2·97	·337	2·70	·370
6 $\frac{2}{3}$	·15	2·78	·360	2·40	·417
5	·2	2·53	·395	1·98	·505
4	·25	2·33	·429	1·72	·582
3 $\frac{1}{3}$	·3	2·16	·463	1·54	·648
2 $\frac{2}{3}$	·35	2·02	·496	1·42	·707
2 $\frac{1}{3}$	·4	1·89	·529	1·32	·756
2 $\frac{1}{4}$	·45	1·78	·562	1·25	·800
2	·5	1·68	·596	1·19	·840
1 $\frac{6}{11}$	·55	1·59	·630	1·145	·874
1 $\frac{3}{5}$	·6	1·50	·666	1·110	·900
1 $\frac{1}{3}$	·65	1·43	·700	1·077	·929
1 $\frac{2}{7}$	·7	1·35	·740	1·057	·945
1 $\frac{1}{3}$	·75	1·28	·778	1·037	·960
1 $\frac{1}{4}$	·8	1·22	·819	1·024	·976
1 $\frac{3}{17}$	·85	1·16	·861	1·013	·986
1 $\frac{1}{2}$	·9	1·11	·903	1·003	·997

EXPLANATION OF SYMBOLS IN TABLES VII. AND VIII.

r , ratio of expansion; $1 \div r$, real cut-off; P_1 , absolute pressure of admission; P_m , mean absolute pressure; $rP_m \div P_1$, ratio of whole gross work of steam on piston to gross work during admission; $P_1 \div rP_m$, ratio of gross work during admission to whole gross work.

INDEX.

- ABSOLUTE** temperature (see Temperature), 228.
Absolute zero, 228.
Accelerating effort, 33.
Acceleration, 18.
Actual energy, 35.
Adhesion of locomotives, 528.
Adiabatic lines, 302, 319.
 for air, 345.
 for steam, 388.
Ether (see Ether).
Air engines, 345.
Air engine, perfect, 347, 352.
 temperature changed at constant pressure, 364.
 temperature changed at constant volume, 362.
 heat transferred at constant pressure, 371.
Air, expansion and elasticity of, 229.
 for furnaces; supply and distribution of, 280, 281, 285, 291.
 flow of, 324.
 passages, 459.
 thermal lines for, 345.
 thermodynamic function for, 346.
 thermodynamic properties of, 318, 319.
 vessels, 148.
Air-pump, 482, 508.
 pump valves, 123.
Angular motion, 3.
 velocity, 4.
Animals, power of, 81.
Anthracite, 275 (see Fuel).
Ash, 274.
 pit, 450, 458.
Asses, work of, 89.
Atmospheric pressure, 109, 225.
Available heat of combustion (see Combustion).
Axis, permanent, 27.
Axles, strength of, 75, 78, 79.
- BACK** pressure (see Steam, Back Pressure of).
Backwater of mill pond, 151.
Baffles, 261, 451.
Balance of centrifugal forces and couples, 27.
 of effort and resistance, 81.
Ball clack, 120.
- Bars, strength of, 66.
Battery, galvanic, 542.
Beam of steam engine, 482, 510.
Beams, strength of, 75.
Binary vapour engines, 444.
Bituminous unguents, 16.
 ingredients of fuel, 273.
 coal, 275 (see Fuel).
Blast pipe, 213, 285, 288, 481, 531.
Blind coal, 265 (see Fuel).
Blow through valve, 481.
Blowing apparatus for furnaces, 282, 290, 451, 459.
Blowing off apparatus, 453, 464, 521.
 in locomotives, 530.
Boiler, parts and appendages of, 451.
 heating surface of (see Heating Surface).
 horse-power of (see Nominal Horse-power).
 room, 462.
 shell, 451, 459.
 stays, 69, 455, 459.
Boilers, efficiency of, 290.
 and furnaces, general arrangements, 419.
 examples of, 469.
 strength of, 67, 70, 459, 466.
Boiling points, 225, 235, 237, 241.
 resistance to, of brine, 242.
Bolts, strength of, 66, 69, 71.
Brakes, 52.
Breast of a water wheel, 184.
 wheels, high, 160, 177.
 wheels, low, 161.
Bridge of furnace, 450, 452.
Brine, boiling points of, 242.
 blowing off, 453, 464.
 pumps, 453, 464.
Bucket hoist, 105.
Buckets of water wheels, 162, 180, 183.
Burning (see Combustion).
Bursting (see Explosion).
Butterfly clack, 123.
- CALORIMETERS** for measuring quantities of heat, 244.
Capacity for heat (see Specific Heat).
Carbon, 263, 272, 273.
Carbonic acid gas, expansion and elasticity of, 229.
 acid gas, 269.

- Carbonic oxide, 269.
 Cataract, 486, 524.
 Centrifugal force, 27.
 couple, 27.
 Channel, flow of water in, 154.
 Charcoal, 274 (see Fuel).
 Chemical action, energy of, 267, 540.
 Chemnitz (see Schemnitz).
 Cheval, force de, 2.
 Chimney, 285, 288, 451, 459.
 Clacks, 117.
 compound, 144.
 relief, 144.
 Clearance, 418.
 Clothing for boilers, 456.
 for cylinders, 481.
 Cloudy vapour, 242.
 Coal, 275 (see Fuel).
 Cocks, 126.
 Coke, 275 (see Fuel).
 Cold well, 481.
 water pump, 481, 508.
 Collar, leather, 128.
 Columns, strength of, 73.
 Combined engines, 482.
 Combustion, 267.
 air required for, 280.
 available heat of, 290.
 rate of, 284.
 total heat of, 267, 270, 277.
 Compression (see Cushioning).
 heating by, 819.
 Concentric cylinder, 502.
 Condensation, 241.
 at high pressure, 412.
 of steam during expansion, 385.
 surface, 265.
 water, net, 389, 401.
 water, total, 481, 507.
 Condenser, 481, 507.
 surface, 481, 509.
 Condensing engines, 478.
 Conduction of heat, 257.
 in cylinders, 421.
 Conical valve, 118, 485.
 divided, 120.
 Connecting mechanism of steam engines,
 510.
 rod, 482.
 rods, strength of, 74.
 Contraction of stream, 94, 102, 150, 156,
 824.
 Convection of heat, 261.
 Cooling surface, 265.
 by expansion, 819.
 Cornish boiler, 472.
 pumping engine, 37, 528.
 Counter, 552.
 Counterpoise, 480 (see Balance).
 Cranes, hydraulic, 183.
 Crank, 482, 511.
 effort on, 511.
 Cranks, strength of, 75, 79.
 Cross breaking, resistance to, 75.
 Cross-heads and tails, strength of, 75.
 Crushing, resistance to, 72.
 Crust, internal, in boiler (see Deposit).
 external, 468.
 increased consumption of fuel caused by,
 468.
 Current, water wheel in an open, 188.
 Cushioning the fluid in engines, 336, 364
 steam, 420.
 Cut off (see Steam, action of).
 valve (see Expansion valve).
 Cylinder, 322, 480, 500.
 cover, 481.
 strength of, 67, 500.
 Cylindrical boiler, 470-474, 476.

DAMPERS, 451, 455.
 Dead plate, 282, 449, 458.
 points, 512.
 Deposit in boilers, 467
 Detached furnace boiler, 279, 283, 449, 458,
 475.
 Deviating force, 26.
 Diagram, indicator (see Indicator).
 Diaphragm valves, 126.
 Direct acting engines, 489, 512, 518, 520,
 525.
 Disc and pivot valve, 123.
 electro-magnetic engine, 546.
 steam engine, 482, 504.
 Donkey engine, 464.
 Double acting steam engine, 50, 479.
 beat valve, 120, 485, 500.
 cylinder steam engine, 50, 481, 501, 503.
 furnace boilers, 282, 473, 474, 476.
 piston engine, 508.
 Draught of furnace, 285.
 Drowned weir, 151.
 Dry coal, 275 (see Fuel).
 Duplex cylinder, 502.
 Dynamometers, 40.

EBULLITION, 241.
 Eccentric, 490.
 loose, 491.
 Economizer (see Regenerator).
 Eduction valves, 480, 496.
 Effect, 40.
 Efficiency, 86.
 conditions of, greatest, in heat-engines,
 344.
 of a fall of water, 91.
 of air engines, 345.
 of electro-magnetic engines, 544.
 of furnace and boiler, 290.
 of mechanism, 422.

- Efficiency of propellers, 550.
 of steam, 475 (see also *Steam, action of*).
 of the fluid in heat engines, 382, 342.
 of turbines, 198.
 of vertical water-wheels, 174.
 of windmills, 218.
- Effort, 80.
- Elasticity of gases, 229.
- Electro-chemical circuit, 542.
- Electro-magnetic attractions and repulsions, 544.
 bar-engine, 547.
 disc-engine, 546.
 engines, 539.
 engines, efficiency of, 544.
 engines, their cost of working, as compared with heat-engines, 541.
 plunger-engine, 548.
- Electro-motive force, 543.
- Energy, actual, 35, 580.
 and work, equality of, 32, 840.
 intrinsic, 813.
 law of the transformation of, 309, 540.
 of chemical action, 267, 540.
 of heat, 299.
 potential, 32, 539.
- Equilibrium valve, 122, 486.
 slide-valve, 489.
- Equivalent, dynamical, of heat, 299.
- Equivalents, chemical, 267.
- Escape valve, 481.
- Ether, formulæ for, 237, 445.
 and steam engine, 445.
 table for, V., 568.
- Evaporation, 235, 241.
 factors of, 256.
 latent heat of (see *Latent heat*).
 measurement of heat by, 254.
 total heat of, 258, 327.
- Exhaust port, 487.
- Expansion by the slide valve, 491.
 cooling by, 319.
 free, 322.
 latent heat of (see *Latent heat*).
 of gases, 229.
 of liquids, 382. *229, 2*
 of solids, 284.
 valves, 480, 498, 499.
- Expansive action of heat in fluids, 810.
 action of steam (see *Steam, action of, on piston*).
- Explosion of boilers, 466.
- FALL of water, 91.
 energy of, 98.
- Fan blower, 290.
- Fan steam engine, 538.
- Feed apparatus, 452, 464, 552.
 pump, 452, 464.
- Feed-water heater, 262, 294, 538.
- Feed-water, net, 389, 401.
 total, 464.
- Fifth powers and squares, 157.
- Fire bars (see *Grate*).
- Fire box, 449, 452.
 strength of, 69.
- Fire doors, 279, 282, 450, 458.
- Fire, temperature of, 283.
- Firing furnaces, 281, 291.
- Flame, 273.
 chamber, flame bed, 450.
- Flap valves, 122, 123.
- Flexible tube valves, 126.
- Flexure, moment of, 75.
- Float in boiler, 453.
- Floats of water wheel (see *Vanes*).
- Flow of water, measurement of, 92.
 through channel, 154.
 through pipes, 113.
- Flues, 450, 452, 461.
 strength of, 70.
- Fluid condition, 236.
- Fly wheels, 59, 482.
- Foot-pound, 1.
- Frame and mechanism of engine, strength of, 520 (see *Strength*).
- Friction, 74.
 heat produced by, 299.
 of fluids, 56, 99.
- Fuel, ingredients of, 273.
 available heat of combustion of, 290.
 kinds of, 274.
 rate of combustion of, 284.
 supply of air to, 280.
 total heat of combustion of, 277.
 waste of, 290.
- Furnace (see *Combustion and Fuel*).
 and boiler, efficiency of, 290, 406, 409.
 and boiler, general arrangements of, 449.
 efficiency of, in air engines, 860, 870.
 examples of, 469.
 front, 450, 458.
 gas engine, 374.
 height of, 457.
- Furnaces, parts and appendages of, 449.
- Fusible plug, 464.
- Fusion, temperatures of (see *Melting points*).
 latent heat of (see *Latent heat*).
- GAB, 490.
- Gas, perfect, 226, 556.
- Gases, expansion and elasticity of, 229, 310, 554, 556.
 flow of, 324.
- Gasification, total heat of, 255, 327.
- Gasket, 129.
- Governors, 68, 158, 480.
- Grate, 285, 449, 455.
- Grates, moving, 283, 457.

- Gravity, 19.
 Grease, 16.
 Grease-cock, 481.
 Guides for piston rod, 482, 512.
 Gyration, radius of, 23.
- HEAD** of water, 91.
 Head, loss of, 100.
 Hearth, 449, 457.
 Heat, 224.
 engines, 228, 382.
 engines, action of fluid on piston, 337.
 dynamical equivalent of, 299.
 latent (see Latent heat).
 mechanical action of (see Thermodynamics).
 quantities of, 243, 300.
 specific (see Specific heat).
 total actual, 305.
 transfer of, 257.
 unit of, 244.
- Heating surface, 262, 293, 461.
 total and effective, 462.
- Height due to velocity, 21.
 table of, 553.
- Hempen packing, 129.
- High pressure steam engines, 478.
- Hoist, water bucket, 105.
- Hoists, water pressure, 133.
- Horse engine, 550.
 power, 2, 40, 50 (see also Indicated power).
 power, effective, of steam engine, 422.
 power, nominal (see Nominal horsepower).
- Horses, work of, 88.
- Hot well, 482.
- Hungarian machine, 144.
- Hydraulic cranes, 133, 138.
 hoists, 133.
 press, 66, 129.
 press, strength of, 69.
 purchases, 133.
 ram, 211.
- Hydrocarbons, as unguents, 16.
 as fuel, 273.
- Hydrogen, 268, 269, 272, 273.
- Ice, melting of, 225, 331.
- Impulse, 20.
 of fluids, 211.
 of water, 163, 211.
- Indicator, steam engine, 47.
 friction of, 422.
 position of, 422.
- Indicated power, 50, 51, 332, 339, 375.
- Indicator diagram, theoretical, 375.
 diagram, disturbances of, 417.
- Induction valves, 480, 486.
- Inertia, 21.
- Inertia, moment of, 22.
 reduced, 28.
- Injection water (see Condensation water)-
 valve, 481, 508.
- Integrals, approximate computation of, 11.
- Isodiabatic lines, 345.
- Isothermal lines, 302.
- JACKET** round steam cylinder, 395, 481.
- Jacketed cylinders, action of steam in (see Steam, dry saturated).
- Jet pump, 218.
- Journals, friction of, 16.
 strength of, 76, 79.
- Junk ring, 129.
- KEYS**, strength of, 71.
- Kilogrammètre, 1.
- Knot, or nautical mile, per hour, 2.
- LAP** of slide valve, 491.
- Latent heat of expansion, 250, 309, 312, 319.
 heat of evaporation, 252, 325, 559, 563, 564.
 heat of fusion, 250, 331.
- Lead of slide valve, 491.
- Leather collar, 128.
 packed piston, 128.
- Levers, strength of, 75.
- Link motion, 497.
- Liquefaction (see Condensation).
- Liquid state, 235.
 water in cylinder, effects of, 395, 421.
- Liquids, expansion of, 232.
- Locomotive steam engines, 469, 528.
 adhesion of wheels, 528.
 air, supply of, 281.
 back pressure in, 382.
 balancing, 530.
 blast pipe, 538.
 combustion in, 285.
 condensing, 412.
 efficiency of furnace and boiler, 293.
 examples of, 532.
 expansion in, 491.
 furnace and boiler, 449, 456, 457, 459, 460, 463.
 heating cylinder, 396.
 link motion, 497.
 regulator, 485.
 resistance of regulator, 413.
 of engine and train, 529.
 safety valves, 465.
 smoke burning, 282.
- Low pressure steam engines, 478.
- MACHINE**, action of, 1.
- Man, work of, 84.
 hole, 452.
- Marine boilers, 474, 477.
 steam engines, 479, 516, 518, 525, 538.

- Mass, 19.
 Mechanism of steam engines, 478.
 resistance and efficiency of, 422.
 Melting (see Fusion).
 points, 225, 235, 251.
 Mercurial barometer, pressure gauge, and
 vacuum gauge, 110.
 thermometer, 238.
 Metallic packing for pistons, 405.
 Mill pond, 150.
 site, 91, 150.
 Modulus of a machine, 89.
 Moment of friction, 17.
 of motion, 21.
 of resistance, 8.
 statical, 8.
 Momentum, 19.
 Mouthpiece of furnace, 450, 458, 476.
 Mud hole, 452.
 Mules, work of, 89.
 Multitubular boilers (see Tubular boilers).

 NOMINAL horse-power of engines, 479.
 of boilers, 478.
 Non-condensing engines, 478, 480.
 Notch board, flow over, 93.

 OIL, 16.
 Orifice, flow of water through, 95.
 Oscillating engines, 482, 503, 518.
 Oven, or detached furnace, 283, 449, 475.
 Overshot water wheels, 160, 177.
 wheels at high speeds, 185.
 Oxen, work of, 89.
 Oxygen, 268, 278.

 PACKING, hempen, 129.
 leather, 128.
 metallic, 505.
 Paddle engines, 516-520, 538.
 Paddles, efficiency of, 550.
 Parallel motion, 482, 512.
 Passages, resistance of, to flow of steam,
 413, 485.
 Peat, 276 (see Fuel).
 Pendulum, revolving, 26.
 Periodical motion, 87.
 Pillars, strength of, 78.
 Pins, strength of, 71.
 Pipes, flow of water through, 112.
 Piston, action of water on, 110, 128.
 of water engine, 128.
 rods, 506.
 strength of, 74.
 valves, 125, 141.
 Pistons of steam and other heat engines,
 832, 480, 505.
 advantages of long stroke, 507.
 speed of, 506.
 Pivots, friction of, 17.

 Plug rod, 486.
 Plunger, 127.
 Pond, mill, 150.
 Ports, steam, 413, 480, 485.
 Posts, strength of, 74.
 Potential energy, 82.
 Power, 40.
 muscular, 81.
 of a fall of water, 91.
 of an overshot wheel, 185.
 of an undershot wheel, 186.
 of turbines, 193.
 of windmills, 218.
 (see also Efficiency).
 Press, hydraulic, 66.
 Pressure, back (see Back pressure).
 gauges, 110, 454.
 intensity of, 4.
 loss of, 418.
 mean effective, 50, 51.
 mean effective in air engines, 858, 859,
 367, 368, 378.
 mean effective in heat engines, 339.
 mean effective in steam engines, 378, 388,
 399, 401.
 various units of, 5, 110, 333.
 Pressures, customary mode of stating, 108,
 427.
 Prime movers defined, 13.
 classed, 80.
 Priming, 481.
 Proof of strength, 65.
 Proving boilers, 466.
 Pump brakes, 66.
 Pumping engines, 523, 525.

 QUANTITIES of heat, 248.
 of heat expressed in foot-pounds, 300.

 RADIATION of heat, 257.
 from fuel, 228, 292.
 Ram, hydraulic, 211.
 Reaction steam engine, 538.
 of water, 178.
 water wheel, 190, 197, 206.
 Reciprocating force, 86.
 Regenerator, 344.
 Regulators (see Throttle valve), 62, 115.
 Release, 421.
 Relief clacks, 144.
 Resistance of electric circuit, 548.
 of locomotive engines and trains, 529.
 of steam engine, 422.
 of steam passages, 413.
 of water pipes and channels (see Flow
 of water).
 to conduction of heat, 257.
 Retort boiler, 470.
 Reversing engines by loose eccentric, 491.
 by link motion, 496.

- Rivets, strength of, 71 (see also Boiler shells).
- Road locomotives, 537.
- Rolling resistance, 17.
- Rotative steam engines, 479.
- Rotatory steam engines, 478, 482, 503.
- Rupture, modulus of, 77.
- SAFETY** valve, 119, 454, 464.
- Sails of windmills, 217, 219.
- Schemnitz machine, 144.
- Screw engines, 523, 525.
propeller, efficiency of, 550.
- Sector cylinders, 503.
- Sediment in boilers (see Deposit).
collector, 453.
- Shafts, 482.
of marine engines, 520.
strength of, 75, 78, 79.
- Shearing, resistance to, 71.
- Side lever engines, 516.
- Single acting steam engines, 50, 333, 334, 339, 478.
- Slide valves, 124, 480, 486.
long, 487.
short, 488.
- Slip dock, hydraulic purchase for, 134.
- Sluices, 153, 156.
- Smoke, 273.
box, 451.
prevention of, 281.
- Snifting valve, 481.
- Solids, expansion of, 234.
melting points of, 235.
- Soot, 273.
- Sound, velocity of, 249, 321.
- Source of water, measurement of, 92.
- Sources of water power, 91.
- Specific heat of liquids and solids, 245, 555.
heat, dynamical, real and apparent, 307, 316.
heat of gases, 248, 318, 554.
- Spheroidal state of fluids, 238.
- Starting, 38.
- Stays (see Boiler stays, Fire box stays).
- Steam, action of, against known resistance, 428.
action of, on piston, 50, 51, 375, 377, 387, 396, 568.
action of, practical examples, 404.
and ether engine, 445.
approximate formulæ, 392, 402.
back pressure of, 381.
chest, 451, 460.
density of, 230, 326, 552, 559, 564.
dry saturated, action of, 396.
elasticity of, 230.
engine, resistance and efficiency of mechanism, 422.
engines classed, 478.
- Steam engines, parts of, 480, 484.
gas, properties of, 255, 320, 327, 430.
how to interpolate quantities in tables, 380.
in unjacketed cylinder, 387.
latent heat of, 252, 325.
passages, 414, 485.
pipe, 413, 454, 480.
pressure of saturation of, 237.
room, 462.
superheated, or steam gas, provisional theory of, 430.
tables relating to action of, IV., 559; VI., 564; VII., VIII., 568; IX., 441; X., 442; XI., 443.
tables, interpolation in, 380.
thermodynamic function and thermal lines for, 383.
total heat of, 327.
valve (see Induction valve).
whistle, 456.
- Steel boilers, 465.
- Steeple engines, 549.
- Stop valve, 454, 480.
- Stopping, 38.
- Stream (see Flow).
- Strength of machines, 64.
- Stroke of piston, advantages of long, 507.
- Struts, iron, 73.
timber, 74.
- Stuffing box, 481.
- Suction pipe, 105.
- Superheating steam, 262, 428, 552.
- Surface blow, 455.
condensation (see Condensation).
cooling (see Cooling surface).
heating (see Heating surface).
- TAPETS**, 486.
- Temperature, 224, 225, 306.
- Tenacity, 66.
- Testing strength, 65.
- Thermal lines, 302.
for air, 345.
for steam, 383.
unit, 244.
- Thermodynamic functions, 309, 314.
functions for air, 346.
functions for steam, 383.
- Thermodynamics, 223, 299.
first law of, 299.
general equation of, 310.
second law of, 306, 307.
- Thermometers, 226, 232, 306.
- Throttle valve, 123, 485.
resistance of to steam, 413, 480.
- Torsion, resistance to, 73.
- Total heat of combustion (see Combustion).
actual heat, 305.
of evaporation (see Evaporation).
of gasification (see Gasification).

- Transport of loads by muscular power, 83.
 Transverse strength, 75.
 Treble cylinder engines, 502.
 Trunk, 481, 482.
 Tubes of boilers and tube plates, 451, 452, 460, 461.
 Tubular boilers, 463, 474, 476.
 Turbines, steam, 538.
 water, 189, 201.
 Turf, 276 (see Fuel).
 Twisting, resistance to, 78.
 and bending, 79.
- UNDERSHOT** water wheels, 161, 186.
 Undulations of indicator diagram, 422.
 Unguenta, 16.
 Unjacketed steam engine, 387.
 Uptake, 451, 475.
- VACUUM** (see Pressure, Customary Mode of Stating; also Steam, Back Pressure of).
 gauges, 110, 481.
 valve, 454.
- Valves**, 117 (see also Clacks).
 chest, 480.
 gearing, 482, 485, 486, 490.
 slide (see Slide valves).
 steam, resistance of, 413.
- Vanes**, impulse of water on, 163.
 best form of, 170.
 friction of water on, 171.
- Vapours**, properties of, 236, 325, 326, 554.
- Velocity**, 2.
 angular, 4.
 of piston (see Piston).
- Vertical-tube boilers**, 461, 476.
 inverted screw marine engine, 525.
- Vortex water wheel**, 191, 193, 197, 198, 207.
- WAGON boiler**, 469.
- Waste- sluice**, 153.
Waste weir, 150.
Water blower, 213.
 bucket engines, 105.
 bucket hoist, 105.
 expansion of, by heat, 109.
 gauge, 454.
 impulse of, 163.
 measurement of flow of, 92.
 meters, 148.
 power, 91.
 power engines, 97.
 pressure engines, 107, 138.
 pressure hoists, 133.
 room, 462.
 tube boilers, 461, 476.
 wheel governors, 153.
 wheel in an open current, 188.
 wheel, vertical, choice of, 177.
 wheels, horizontal (see Turbines).
 wheels, vertical, 150, 160, 174, 177, 186.
- Weir**, flow over, 93, 150.
- Windmills**, 214.
- Wire-drawn steam**, 418, 417.
- Wood**, 276 (see Fuel).
 hearth for burning, 457.
- Work**, 1.
 against an oblique force, 6.
 against gravity, 8.
 against varying resistance, 9.
 algebraical expressions for, 5.
 during retardation, 35.
 in terms of angular motion, 8.
 in terms of pressure and volume, 4.
 of acceleration, 18.
 represented by an area, 8.
 summary of, 24.
 summation of quantities of, 6.
 useful and lost, 13.
- Wrenching**, resistance to, 78.
- Z-CRANK engine**, 482.