

## Experimental demonstration of a binary wire for quantum-dot cellular automata

A. O. Orlov,<sup>a)</sup> I. Amlani, G. Toth, C. S. Lent, G. H. Bernstein, and G. L. Snider  
*Department of Electrical Engineering, University of Notre Dame, Indiana 46556*

(Received 9 February 1999; accepted for publication 18 March 1999)

Experimental studies are presented of a binary wire based on the quantum-dot cellular automata computational paradigm. The binary wire consists of capacitively coupled double-dot cells charged with single electrons. The polarization switch caused by an applied input signal in one cell leads to the change in polarization of the adjacent cell and so on down the line, as in falling dominos. Wire polarization was measured using single islands as electrometers. Experimental results are in very good agreement with the theory and confirm there are no metastable states in the wire. © 1999 American Institute of Physics. [S0003-6951(99)03919-4]

Recently, significant progress has been achieved in experimental studies of quantum-dot cellular automata (QCA)—a transistorless computational paradigm that addresses the issues of device density, interconnect problems, and power dissipation.<sup>1–3</sup> QCA architecture utilizes arrays of basic cells to implement digital logic functions where digital data are encoded in the arrangements of individual electrons within cells. A typical QCA cell consists of four dots located at the vertices of a square. When a cell is charged with two excess electrons, they occupy diagonal sites due to mutual electrostatic repulsion. The two diagonal electron arrangements (“polarizations”) are energetically equivalent ground states of the cell. A key element of this paradigm, a single QCA cell, has been experimentally demonstrated.<sup>4,5</sup>

While from an architectural point of view a four-dot QCA cell has some advantages, the basic QCA concept will not change if a cell is defined as two dots charged with a single excess electron instead of four dots with two excess electrons. A two-dot cell exhibits the same bistable behavior as a four-dot cell. The two polarizations of such a double-dot (DD) cell will be represented by the location of a single excess electron. The main difference between the two- and four-dot cells is that in the ground state, two adjacent DD cells have opposite polarizations, while adjacent four-dot cells have the same polarization. In either case, polarization change in an array of cells is induced by causing an electron to switch positions in one set of dots, which induces an opposite electron switch in an adjacent set of dots, changing the electron arrangement. Quantitatively, we define the charge polarization of a cell  $D_i D_j$  as the fraction of an electron charge corresponding to a charge difference between the dots:

$$P_{ij} = (Q_i - Q_j) / e. \quad (1)$$

In this letter we present a demonstration of a binary wire—a linear array of cells capacitively connected in series, as shown in Fig. 1(a). If polarization of a DD cell is forced from  $-1$  to  $+1$ , for example, the neighboring cell will flip from  $+1$  to  $-1$ . This principle is exploited to construct a

QCA wire. The polarization change at the input of the wire leads to a successive change in polarization of all cells along the wire as the system relaxes to a new ground state.<sup>1</sup> Since in the QCA architecture signals are transmitted with no current flowing down the wire, power dissipation is extremely small.<sup>2</sup>

There are different views on the dynamic behavior of a QCA binary wire. Lent and Tougaw<sup>2,3</sup> performed calculations of the time-dependent propagation of the polarization “kink” down the line of cells at zero temperature. They simulated various imperfections in the wire, including random variations in the size of the cells in the wire, errors in the intercellular spacing, and even the presence of an extra electron in the cell. The wire nevertheless functions properly, correctly transmitting either input state, because the highly nonlinear response function acts to correct mistakes and restore the signal level.

By contrast, Anantram and Roychowdhury<sup>6</sup> claim that a binary wire will always be stuck in a metastable state at zero temperature, and finite-temperature operation is possible only in a very narrow window of coupling parameters, even in a line free of fabrication defects. Other authors also have objected that even a small intercellular coupling error between cells in a wire would result in wire failure.<sup>7</sup> We address these basic objections. We show that a QCA wire functions properly, and that even in the presence of a severe

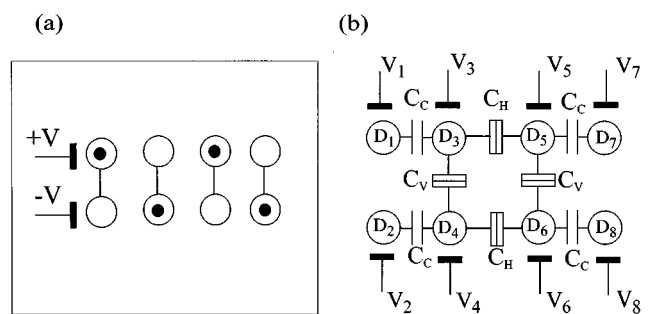

FIG. 1. (a) QCA binary wire. Black dots represent excess electrons. (b) Schematic diagram of experiment. The wire consists of dots  $D_1$ – $D_6$ .  $D_7$  and  $D_8$  are electrometer dots. External leads and tunnel junctions for the dots and the electrometers are not shown.

<sup>a)</sup>Electronic mail: orlov.1@nd.edu

spacing error, the polarization flip propagates correctly down a line of cells.

The device under study is shown in the simplified schematic in Fig. 1(b). (A detailed schematic for a related experiment has been published elsewhere.<sup>5</sup>) It consists of four pairs of metal islands labeled  $D_1D_2$ ,  $D_3D_4$ ,  $D_5D_6$ , and  $D_7D_8$ , forming a linear array of cells. Double-dots are formed by connecting the islands in series by a tunnel junction with capacitance of  $C_V \approx 2.5 e/mV$ . Dots  $D_1D_2$  and  $D_7D_8$  are implemented as separate islands.

Aluminum islands and leads are defined by electron-beam lithography. Al/AIO<sub>x</sub>/Al tunnel junctions are fabricated using the standard Dolan-bridge technique.<sup>8</sup> Resistances of tunnel junctions  $R_j \sim 200 k\Omega \gg h/e^2$ , while total island capacitances  $C_\Sigma \sim 6 e/mV$ , are small, therefore, at low temperatures ( $<0.5$  K) each dot contains an integer number of electrons. Experiments are performed in a dilution refrigerator, the electron temperature of the device is 70 mK.<sup>9</sup> A magnetic field of 1 T is applied to suppress superconductivity of Al. Conductance of the cells and electrometers is measured using lock-in amplifiers with excitations of 4–10  $\mu V$  at frequencies of 10–200 Hz. For proper wire operation, each cell is initialized using gates, so that an excess electron has equal probability to occupy each dot of a cell.<sup>4</sup> In this state each cell has zero polarization.

To study the wire operation, we perform experiments on one, two, and three DD cells, and compare the experimental data with theory.<sup>1–3</sup> The theoretical results are obtained by minimizing the classical electrostatic energy for the array of islands, capacitors, and voltage leads. The minimum energy charge configuration is calculated subject to the condition that island charge be an integer multiple of electron charge. Finite-temperature effects are obtained by performing thermodynamic averaging over all energetically accessible charge configurations. The values of circuit capacitances were measured prior to the experiment<sup>4,5</sup> and included in calculations along with estimated parasitic layout capacitances. Coupling between “cells” in the line is different:  $D_3D_4$  and  $D_5D_6$  are coupled with larger junction capacitances  $C_H \approx 1.8 e/mV$ , while the  $D_1D_2$  is coupled to  $D_3D_4$  with smaller lateral capacitances  $C_C = 0.55 e/mV$ . To detect the change in the wire polarization, dots  $D_7$  and  $D_8$  are used as electrometers in a noninvasive configuration,<sup>10</sup> where each electrometer dot potential is kept constant by a feedback gate bias.

An important characteristic energy of a line of QCA cells is  $E_K$ , the so-called “kink energy.” The energy  $E_K$  is the energy difference between the line in the “correct” ground state and the first excited state in which the polarizations of one pair of adjoining cells is “wrong.” Since we have different coupling between cells, the kink energy differs along the line. In a link between the first and second cells,  $E_K^{(1)} \approx 7 \mu eV$ ; between the second and third,  $E_K^{(2)} \approx 12 \mu eV$ , and for a single DD,  $E_K^{(3)} \approx 50 \mu eV$  (in the latter case gates are acting as a wrong cell). If  $kT$  is comparable to  $E_K$ , the polarization of a cell becomes weak, because the “wrong” polarization corresponding to an excited state becomes accessible.

We start with a study of a polarization flip in a single DD cell. As we change an input gate bias of  $V_5$  and  $V_6$  in a

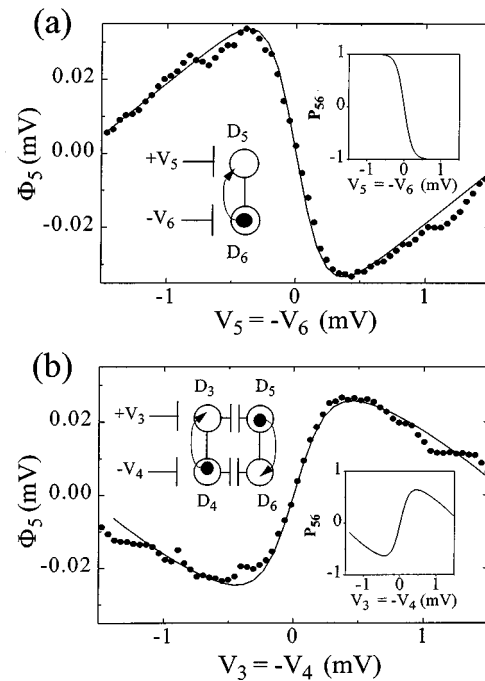

FIG. 2. (a) Demonstration of a DD cell polarization flip. Measured (dots) and calculated (line) cell response to input push-pull gate bias  $V_5 = -V_6$ . Inset: calculated polarization change in  $D_5D_6$ . (b) Polarization flip in two DD cell wire. Measured (dots) and calculated (line) response to the input push-pull gate bias  $V_3 = -V_4$ . Inset: calculated polarization change in  $D_5D_6$ .

push-pull ( $V_5 = -V_6$ ) manner, the polarization of the cell changes. Figure 2(a) shows the measured potential on dot  $D_5$  (the potential on  $D_6$  has the same magnitude, but the opposite phase) along with the theory, and a corresponding polarization change is shown in the inset of the Fig. 2(a). Note that the only fitting parameter we use is a background charge, which adds a rigid shift to the plot. For a single DD, the polarization change from +1 to -1 can be obtained by applying appropriate gate biases to force an excess electron from the bottom island and lock it in the top island, because  $E_K^{(3)}/kT > 10$ , where  $kT \approx 6 \mu eV$  is the thermal energy of electrons at 70 mK. Next, we study a wire consisting of two DD cells. Here, a polarization change in  $D_3D_4$  induced by the gate voltages  $V_3$  and  $V_4$  causes  $D_5D_6$  to flip its polarization to make it the opposite to that of  $D_3D_4$ . For our device at 70 mK, theory<sup>1–3</sup> predicts that swapping an electron in  $D_3D_4$  causes polarization change in  $D_5D_6$  to vary from -0.64 to +0.64, since  $E_K^{(2)}$  is only twice as large as  $kT$ . Figure 2(b) shows measured and calculated dot potentials and a corresponding charge polarization in  $D_5D_6$  caused by an electron exchange in  $D_3D_4$ . The phase of the signal, as expected, is opposite to that seen for a single DD cell. Again, a good match between theory and experiment is observed. Finally, a wire consisting of three cells is studied. In this case a polarization flip in a “cell”  $D_1D_2$  produced by simultaneous addition of an electron to  $D_1$  and removal of an electron from  $D_2$ , leads to the opposite electron movement in  $D_3D_4$ , which in turn leads to polarization change in the output cell  $D_5D_6$ . The measured electrometer signal, along with the theory, is shown in Fig. 3. The voltage change is again in phase with that of a single DD. Now the wire has a very weak coupling between  $D_1D_2$  and  $D_3D_4$ , which simulates a spacing error. In

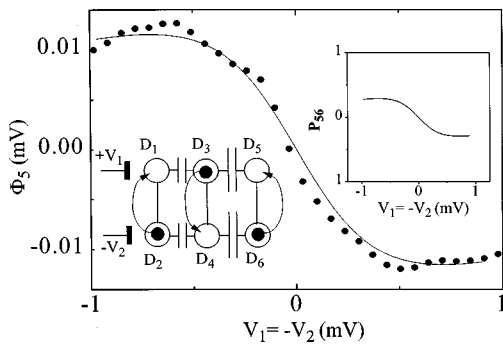

FIG. 3. Polarization flip in a three DD cell wire. Measured (dots) and calculated (line) response to the input push-pull gate bias  $V_1 = -V_2$ . Experimental curve is an average of four successive scans. Inset: calculated polarization change in  $D_5D_6$ .

this case,  $E_K^{(1)}/kT \sim 1$ , degrading the polarization of the wire and making cell-cell response almost linear, rather than strongly bistable. However, the polarization flip still propagates down the line. Calculated charge populations in the dots along the wire for 70 mK are shown in Fig. 4(a). Here, a complete electron switch in  $D_1D_2$  forces the polarization in  $D_5D_6$  to change from  $+0.29$  to  $-0.29$ . Though small, a polarization flip is clearly observed in experiment, and matches the theory,<sup>1-3</sup> while according to Anantram<sup>6</sup> a polarization kink will not propagate down such a wire, due to an ‘‘incorrect’’ coupling parameter, leaving the system in a metastable state.

In recently published results<sup>11</sup> we demonstrated a correlation in transport through capacitively coupled DDs. Lowering of conductance occurs simultaneously in two coupled DDs when they are at the point of switching. Similarly, in the binary wire, conductance of each DD goes down at the point of switching. Near that point, thermal energy causes the entire line to switch back and forth between the two possible polarizations. The frequency of thermally activated

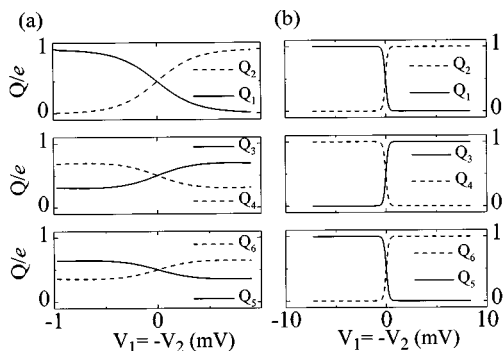

FIG. 4. (a) Theoretical calculations of charges in the three-cell wire as a function of input  $V_1 = -V_2$  at 70 mK. (b) Theoretical calculations of charges in the three-cell wire as a function of input  $V_1 = -V_2$  at 70 mK. All capacitances are reduced by a factor of 10 compared to (a).

switching, which can be used to estimate a lower bound of QCA operation, is about 90 MHz at 70 mK. This, again, suggests that there is no metastable state in our QCA wire and a lower bound of operating frequency is in the MHz range.

To show that thermal smearing is the only source of polarization weakening in our wire, we performed theoretical calculations for a wire having all capacitances reduced by a factor of 10, while the ratio  $C_H/C_C = 3.3$  is kept the same as in the experiment (such a wire can be assembled using today’s technology, by, for instance, particle manipulation techniques using an atomic force microscope<sup>12</sup>). The ratio  $(E_K/kT)$  is now greater than 10 even for the weakest link in this wire, leading to a complete polarization flip along the wire [Fig. 4(b)]. This confirms the ability of the wire to recover from a polarization disruption caused by even a severe imperfection associated with weak coupling.

In conclusion, we present the demonstration of a QCA-based binary wire. The experimental results for one, two, and three cell wires are in good agreement with theory.<sup>1-3</sup> We model a severe wire imperfection by unequal coupling capacitances, and still find a clear indication of the polarization flip. This confirms that there is no metastable state in the wire. The polarization degradation along the wire observed in the experiment is due solely to temperature smearing of charge quantization. Improvements in nanotechnology will make it possible to create QCA binary wires able to transfer complete polarization changes at higher temperatures and to tolerate imperfections in fabricated devices.

This research was supported in part by DARPA, ONR (Grant No. N0014-95-1-1166), and NSF (G.H.B.). The authors wish to thank W. Porod and J. Merz for helpful discussions.

<sup>1</sup>C. S. Lent and P. D. Tougaw, Proc. IEEE **85**, 541 (1997).  
<sup>2</sup>P. D. Tougaw and C. S. Lent, J. Appl. Phys. **80**, 4722 (1996).  
<sup>3</sup>C. S. Lent, P. D. Tougaw, W. Porod, and G. H. Bernstein, Nanotechnology **4**, 49 (1993).  
<sup>4</sup>A. O. Orlov, I. Amlani, G. H. Bernstein, C. S. Lent, and G. L. Snider, Science **277**, 928 (1997).  
<sup>5</sup>I. Amlani, A. O. Orlov, C. S. Lent, G. L. Snider, and G. H. Bernstein, Appl. Phys. Lett. **71**, 1730 (1997).  
<sup>6</sup>M. P. Anantram and V. Roychowdhury, Proceedings of the 4th Workshop on Physics and Computation (New England Complex Systems Institute, Cambridge, MA, 1996), p. 17.  
<sup>7</sup>R. Landauer, IEEE Trans. Electron Devices **43**, 1637 (1996).  
<sup>8</sup>T. A. Fulton and G. J. Dolan, Phys. Rev. Lett. **58**, 109 (1987).  
<sup>9</sup>To infer the electron temperature, we used the peak fitting method described in Single Electron Tunneling, edited by H. Grabert and M. H. Devoret (Plenum, New York, 1992), Chap. 5, p. 181.  
<sup>10</sup>G. L. Snider, A. O. Orlov, I. Amlani, G. H. Bernstein, C. S. Lent, and J. Merz (unpublished).  
<sup>11</sup>A. O. Orlov, I. Amlani, G. Toth, C. S. Lent, G. H. Bernstein, and G. L. Snider, Appl. Phys. Lett. **73**, 2787 (1998); G. H. Bernstein, I. Amlani, A. O. Orlov, C. S. Lent, and G. L. Snider (unpublished).  
<sup>12</sup>S.-B. Carlsson, T. Junno, L. Montelius, and L. Samuelson (unpublished).