

Example: Effect of coefficient quantization

Elliptic filter of order $N = 12$ (example taken from [Oppenheim, Schaffer, 1999])

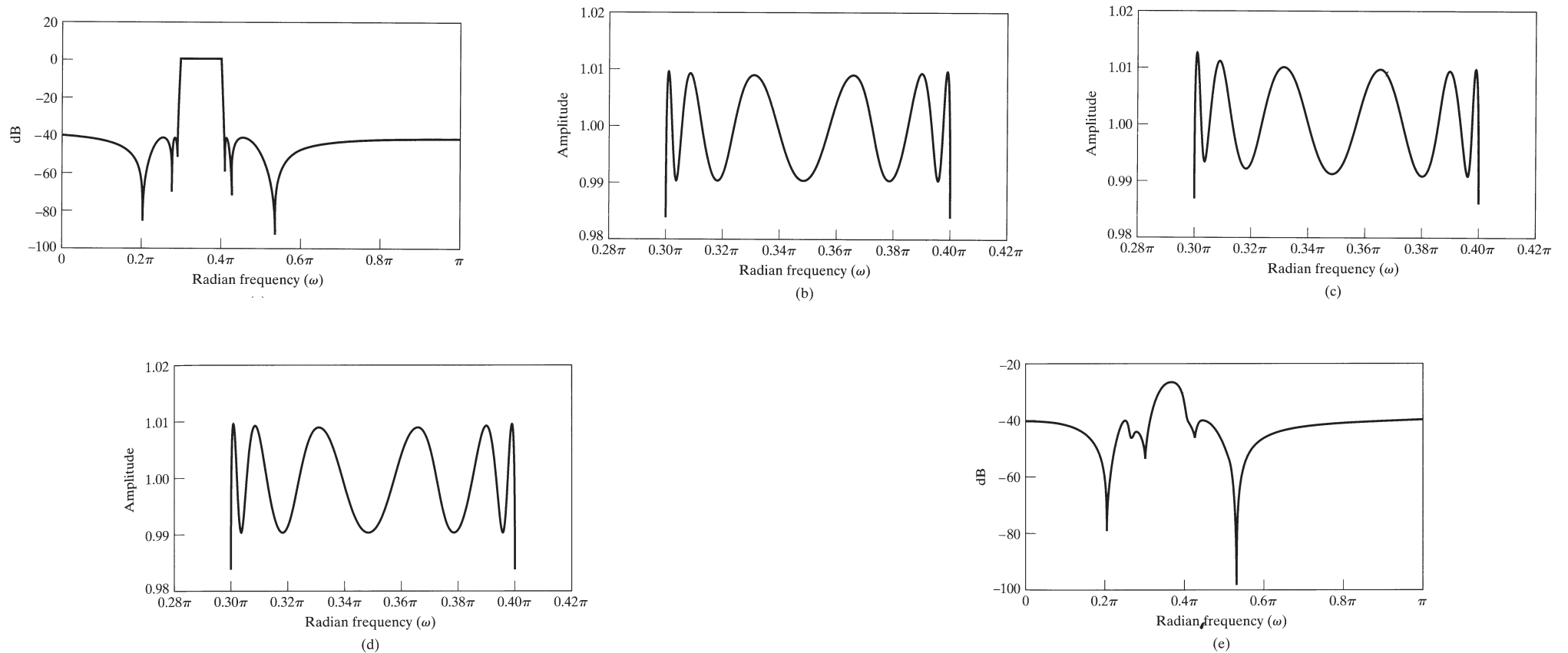

Unquantized: (a) Magnitude frequency response $20 \cdot \log_{10} |H(e^{j\omega})|$, (b) Passband details

Quantized with $b = 16$ bits: (c) Passband details for cascade structure, (d) Passband details for parallel structure, (e) Magnitude frequency response (log) for direct structure

Pole locations of quantized second-order sections

$$H(z) = \frac{1}{1 - (2r \cos \theta) z^{-1} + r^2 z^{-2}}$$

Poles: $z_{\infty 1,2} = r e^{\pm j\theta}$

Coefficients: $a_1 = -2r \cos \theta, a_2 = r^2$

Stability condition: $|r| \leq 1$

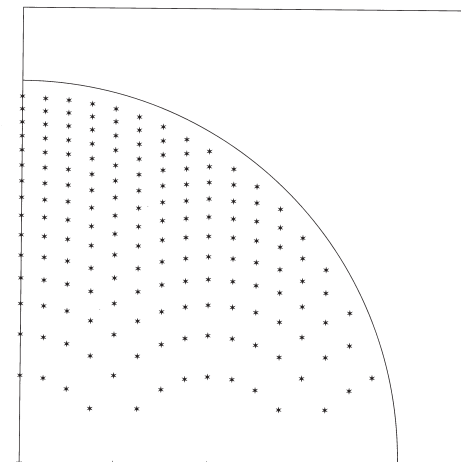
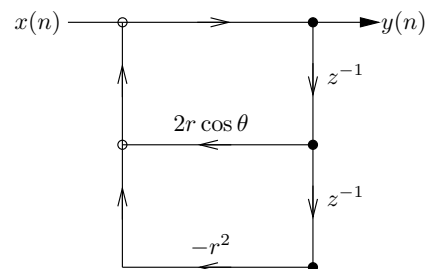

Alternative: *Coupled-form realization*

$$y_1(n) = x(n) + r \cos \theta y_1(n - 1) - r \sin \theta y(n - 1),$$

$$y(n) = r \sin \theta y_1(n - 1) + r \cos \theta y(n - 1),$$

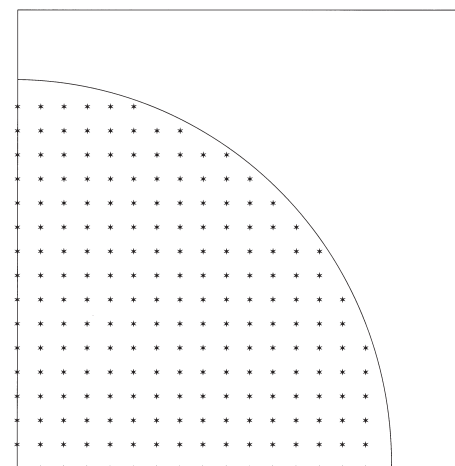
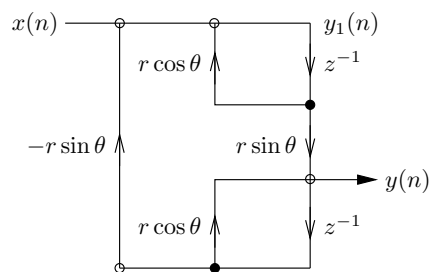

Round-off effects

Direct-form I

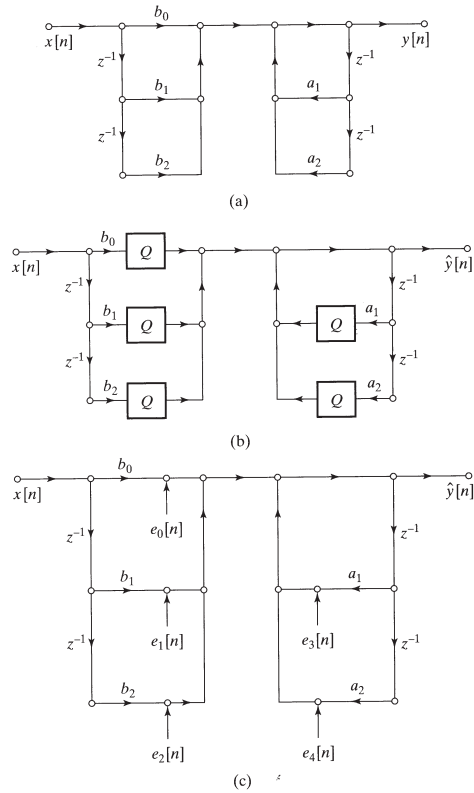

Direct-form I

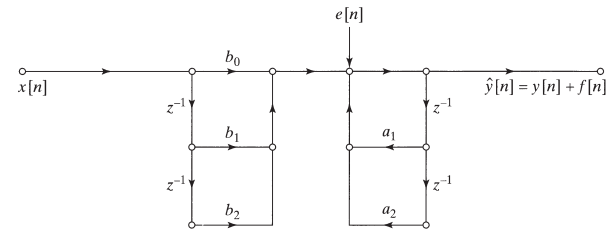

(from

Direct-form II

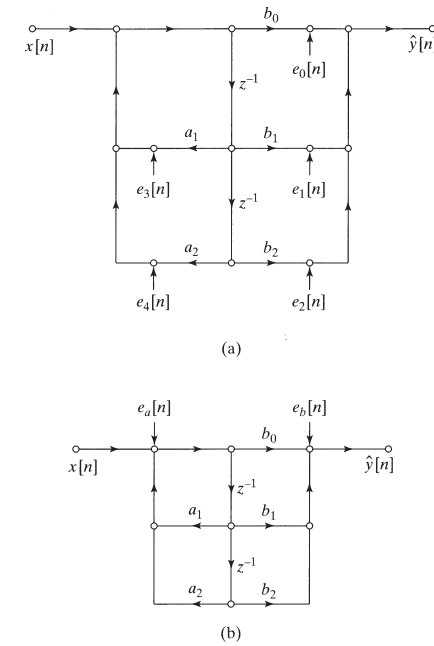

[Oppenheim, Schaffer, 1999]