

***Bonus Vetus* OLS:  
A Simple Approach for Addressing the “Border Puzzle”  
and other Gravity-Equation Issues\***

Scott L. Baier  
The John E. Walker Department  
of Economics  
Clemson University  
Clemson, SC 29634  
and the Federal Reserve Bank  
of Atlanta, Atlanta, GA 30309  
[sbaier@clemson.edu](mailto:sbaier@clemson.edu)

Jeffrey H. Bergstrand  
Department of Finance  
Mendoza College of Business  
and Kellogg Institute for  
International Studies  
University of Notre Dame  
Notre Dame, IN 46556  
[bergstrand.1@nd.edu](mailto:bergstrand.1@nd.edu)

Abstract

Motivated to solve the “border puzzle” of Canadian-U.S. trade, theoretical foundations for the gravity equation of international trade were refined recently to emphasize the importance of the endogeneity of multilateral price (resistance) terms, cf., Anderson and van Wincoop (2003). While region-specific fixed effects can also generate consistent estimates of gravity-equation coefficients, cf., Feenstra (2004), Anderson and van Wincoop argue that proper computation of general equilibrium comparative statics requires custom estimation of the entire nonlinear system of trade flow and price equations. We show in this paper that these multilateral price terms are critical, but nonlinear estimation is not. Virtually *identical* results can be obtained using “good old” ordinary least squares – *bonus vetus* OLS. The key is using a first-order log-linear Taylor-series expansion to approximate the multilateral price terms. Among several findings, we note just three. First, the approximation allows us to solve for a simple log-linear gravity equation revealing a fundamental theoretical relationship among bilateral trade flows, regional and world incomes, and bilateral, multilateral, and world trade costs. Second, we provide econometric and simulation results supporting that virtually identical coefficient estimates *and comparative statics* can be obtained much more easily by estimating a reduced-form gravity equation including theoretically-motivated exogenous bilateral, multilateral, and world resistance terms. Third, we show that our methodology generalizes to other settings as well, working just as effectively to explain *world* trade flows.

March 2006

\*The authors are grateful to the National Science Foundation for financial support, under grants SES 0351018 (Baier) and SES 0351154 (Bergstrand).

JEL Code: F1

***Bonus Vetus OLS:***  
**A Simple Approach for Addressing the “Border Puzzle”  
and other Gravity-Equation Issues**

**1. Introduction**

For nearly a half century, the gravity equation has been used to explain econometrically the *ex post* effects of economic integration agreements, national borders, currency unions, stocks of immigrants, language, and numerous other measures of “trade costs” on bilateral international trade flows. Until recently, researchers typically focused on a simple specification akin to Newton’s Law of Gravity, whereby the bilateral trade flow from region *i* to region *j* was a multiplicative (or log-linear) function of the two countries’ gross domestic products (GDPs), their bilateral distance, and typically an array of bilateral dummy variables assumed to reflect the bilateral trade costs between that pair of regions (e.g., common land border, common language, bilateral trade agreement, etc.); we denote this the “traditional” gravity equation specification. This traditional gravity equation gained acceptance among international economists and policymakers in the last 25 years for at least three reasons: formal theoretical *economic* foundations surfaced for a specification similar to the traditional gravity model (cf., Anderson, 1979; Helpman and Krugman, 1985; Bergstrand, 1985); consistently strong empirical explanatory power (high  $R^2$  values); policy relevance for analyzing the multitude of free trade agreements over the past 15 years.

However, the traditional specification has come under scrutiny. First, since bilateral trade flows are determined in an *N*-region world ( $N > 2$ ), the traditional specification ignores the fact that the “remoteness” of regions *i* and *j* from the rest-of-the-world’s (ROW’s) regions should influence the volume of trade from *i* to *j* and the economic size of the ROW’s regions matters as well. Second, applications of the traditional gravity equation to study bilateral trade costs often yielded seemingly implausible findings. For instance, coefficient estimates for dummy variables representing the effects of international economic integration agreements (EIAs) on international trade were frequently negative (cf., Frankel, 1997) and estimates of the effects of national borders (that is, a national EIA) on intra-continental inter-regional trade flows were often seemingly implausibly high (cf., McCallum, 1995; Helliwell, 1998).<sup>1</sup> The latter finding – now famously termed McCallum’s “border puzzle” – inspired a cottage industry of papers in the international trade literature to explain this result, cf., Michael A. Anderson and Stephen L.S. Smith (1999a, 1999b) and John F. Helliwell (1996, 1997, 1998), as well as a new approach to international macroeconomic issues.

While two early formal theoretical foundations for the gravity equation with trade costs – first Anderson (1979) and later Bergstrand (1985) – addressed the role of “multilateral” prices, a solution to the

---

<sup>1</sup>A nation, of course, can be considered an EIA of sub-national regions.

border puzzle surfaced in Anderson and van Wincoop (2003), which refined the theoretical foundations for the gravity equation to emphasize the importance of accounting properly for the endogeneity of prices in the gravity model. Three major conclusions surfaced from the Anderson and van Wincoop (henceforth, A-vW) study, “Gravity with *Gravitas*.” First, a complete derivation of a standard (Armington conditional) general equilibrium model of bilateral trade in a multi-region ( $N > 2$ ) setting with iceberg trade costs suggests that traditional cross-section empirical gravity equations have been misspecified owing to the omission of theoretically-motivated *multilateral* (price) resistance terms for exporting and importing regions. Second, to properly estimate the full general equilibrium comparative-static effects of a national border or an EIA, one needs to estimate these multilateral resistance (MR) terms for any two regions with *and* without a border (in a manner consistent with theory). Third, due to the underlying nonlinearity of the structural model to explain trade flows, estimation requires a custom nonlinear-least-squares (NLLS) program to account properly for the endogeneity of prices.

While the A-vW approach yields consistent, efficient estimates of gravity equation coefficients for the effects of national borders or EIAs (in the absence of measurement and specification bias), Feenstra (2004, Ch. 5) notes that a “drawback” to the estimation strategy is that it requires a custom NLLS program to obtain estimates. One critical reason the gravity equation has become the workhorse of empirical international trade in the past 25 years is that one can use ordinary linear least squares (OLS) to explain trade flows and potentially the impact of policies (such as national borders or EIAs) on such flows. Unfortunately, the need to apply custom NLLS estimation will likely continue to impede incorporating these important price terms into estimation of gravity equations using the A-vW approach, in favor of an “alternative.”

The alternative – and computationally less taxing – approach to estimate unbiased gravity equation coefficients, which also acknowledges the influence of theoretically-motivated MR terms, is to use region-specific fixed effects, as noted in A-vW and Feenstra (2004). An additional benefit is that this method avoids the measurement error associated with measuring regions’ “internal distances” for the MR variables. Indeed, van Wincoop himself – and nearly every gravity equation study since A-vW – has employed this simpler technique of fixed effects, cf., Andrew Rose and Eric van Wincoop (2001) and Rose (2004). Using the case of McCallum’s border puzzle as an example, Feenstra (2004, Ch. 5 Appendix) shows that fixed-effects estimation of the gravity equation can generate unbiased estimates of the *average* border effect of a pair of countries.

However, fixed-effects estimation also has drawbacks. First, without the structural system of equations, one still cannot generate region- or pair-specific comparative statics; fixed effects estimation

precludes estimating MR terms with *and* without EIAs.<sup>2</sup> Second, many explanatory variables of interest are region specific; using region-specific fixed effects precludes direct estimation of partial effects of numerous potentially-important explanatory variables. For instance, typical gravity studies often try to estimate the effects of exporter and importer populations, immigrant stocks, or internal infrastructure measures on bilateral trade; such variables would be subsumed in the fixed effects.

Consequently, the empirical researcher faces a tradeoff. The advantage of the A-vW customized-NLLS-estimation approach is that it can potentially generate consistent, efficient estimates of average border effects and comparative statics; the disadvantage is that it is computationally burdensome relative to OLS and subject to measurement error associated with internal distance indexes. The advantage of Feenstra's fixed-effects estimation approach is that it uses OLS and avoids internal distance measurement error for MR terms; the disadvantage is that one cannot retrieve the multilateral price terms to generate quantitative estimates of comparative-static effects without also employing the structural system of equations. Is there a way to estimate consistently gravity equation parameters – and compute region-specific or pair-specific comparative statics – using “good old” OLS?

This paper has two major goals. First, we offer a simple OLS technique for estimating average effects *and* comparative statics from a gravity equation including theoretically-motivated *exogenous* multilateral resistance terms. The advantage of this approach over A-vW is that “good old” ordinary least squares – *bonus vetus* OLS – is computationally simple. The advantage over fixed effects is that we can then provide ready quantitative estimates of comparative statics using the estimated coefficients *without* employing the structural system of equations. We can estimate the comparative statics analytically. We do not dispute that A-vW's NLLS procedure provides consistent, efficient estimates of the gravity equation parameters. However, for a very small loss of efficiency, our procedure – henceforth, “BV-OLS” – offers an enormous gain in estimation simplicity and economic transparency for many practical contexts. Moreover, while simulations show that our BV-OLS approximation results in a trivially small estimation bias, we also show econometrically that the bias is small relative to other potential biases associated with mis-measurement of internal distances and other potential specification errors acknowledged by A-vW. The key methodological innovation for this literature is the use of a first-order log-linear Taylor-series expansion centered around a symmetric world to derive an estimable OLS equation that includes theoretically-motivated exogenous variables to capture the influence of multilateral (and world) resistance

---

<sup>2</sup>In their robustness analysis, Anderson and van Wincoop themselves demonstrate evidence using fixed-effects for unbiased estimates of the *average* border effect. In correspondence, Eric van Wincoop notes that “people often introduce the region fixed effects to the gravity equation referring to our paper for motivation but then fail to compute (using the system of structural equations) changes in the multilateral resistance variables when doing comparative statics” (e-mail, August 24, 2004).

terms. The Taylor-series expansion is rarely used by trade economists but is commonly used in modern macroeconomics.<sup>3</sup>

Second, to maintain tractability for the reader, we apply our technique to trade flows using the same context and data sets as McCallum, A-vW, and Feenstra. However, the insights of our paper have significant potential to be used in numerous related contexts assessing trade costs, especially estimation of the effects of tariff reductions and free trade agreements on world trade flows – the most common usage of the gravity equation. A-vW argue that – since the gravity equation has been used traditionally to explain cross-sectionally the effects of a variety of policy-induced, cultural, and geographic factors on world trade flows – “all can be improved with our methods” (2003, p. 172). We show that the linear-approximation approach of BV-OLS works just as effectively in the context of *world* (intra- and inter-continental) trade as in the narrower McCallum-AvW-Feenstra context of regional (intra-continental) trade. Using Monte Carlo techniques we demonstrate that the estimated bias (of the distance elasticity) of BV-OLS over nonlinear least squares for world trade is less than *0.5 of one percent*, smaller than that for intra-continental trade flows. Moreover, we demonstrate clearly the substantive reduction in bias using BV-OLS relative to the traditional OLS specification as well as an OLS specification using “atheoretical” measures of remoteness.

The remainder of the paper is as follows. Section 2 discusses the gravity equation literature and A-vW analysis to motivate our paper. Section 3 uses a first-order log-linear Taylor-series expansion to motivate a simple OLS regression equation (BV-OLS) that can be used to estimate average effects *and* comparative statics. Section 4 shows that BV-OLS works; we apply the estimation technique suggested by section 3 to the McCallum-A-vW-Feenstra data set and compare our coefficient estimates to these papers’ findings. Section 5 compares the comparative-static-effect estimates from BV-OLS to those of A-vW and provides intuition for why BV-OLS works in the context of the theoretical general equilibrium model. Section 6 shows that BV-OLS works well in general; we use Monte Carlo simulations to show that estimated border effects using “good old” OLS are virtually identical to those using A-vW’s technique either in the context of *interregional* trade flows (the McCallum-AvW-Feenstra context) or in the context of *international* trade flows (the typical empirical context). Section 7 explains why BV-OLS works so well, addressing the empirical irrelevance of higher-order terms. Section 8 concludes.

## 2. The Gravity Equation and Prices

The gravity equation is now considered the empirical workhorse for studying interregional and

---

<sup>3</sup>By “loss of efficiency” in this paragraph, we mean that our approach uses a first-order approximation of the underlying system of equations.

international trade patterns, cf., Frankel (1997), Eichengreen and Irwin (1998), and Feenstra (2004). Early applications of the gravity equation – Tinbergen (1962), Linnemann (1966), Aitken (1973), and Sapir (1981) – assumed a specification similar to that used in McCallum (1995):

$$\ln \mathbf{X}_{ij} = \beta_0 + \beta_1 \ln \mathbf{GDP}_i + \beta_2 \ln \mathbf{GDP}_j - \beta_3 \ln \mathbf{DIS}_{ij} + \beta_4 \mathbf{ADJACENCY}_{ij} + \beta_5 \mathbf{EIA}_{ij} + \varepsilon_{ij} \quad (1)$$

where  $\mathbf{X}_{ij}$  denotes the value of the bilateral trade flow from region  $i$  to region  $j$ ,  $\mathbf{GDP}_i$  ( $\mathbf{GDP}_j$ ) denotes the nominal gross domestic product of region  $i$  ( $j$ ),  $\mathbf{DIS}_{ij}$  denotes the distance (typically in miles or nautical miles) from the economic center of region  $i$  to that of region  $j$ ,  $\mathbf{ADJACENCY}_{ij}$  is a dummy variable assuming the value 1 (0) if two regions share (do not share) a common land border, and  $\mathbf{EIA}_{ij}$  is a dummy variable assuming the value 1 (0) if two regions share (do not share) an economic integration agreement. In the McCallum Canada-U.S. context,  $\mathbf{EIA}_{ij}$  would be a national “border” dummy reflecting membership in the same country and  $\mathbf{ADJACENCY}_{ij}$  was ignored.<sup>4</sup> Traditionally, economists have focused on estimates of, say,  $\beta_5$ , an estimate of the “average” (treatment) effect of an EIA on trade from  $i$  to  $j$ . As discussed in the early gravity equation studies cited above, traditional specification (1) excludes *price* terms. The rationale for their exclusion in these studies was that prices were endogenous and consequently would not surface in the reduced-form cross-section bilateral trade flow equation.<sup>5</sup>

However, theoretical foundations in Anderson (1979), Bergstrand (1985), Deardorff (1998), Eaton and Kortum (2002), A-vW (2003), and Feenstra (2004) all suggest that traditional gravity equation (1) is likely misspecified owing to the omission of measures of multilateral resistance (or prices). In reality, the bilateral trade flow from  $i$  to  $j$  is surely influenced by the prices of (substitutable) products in the other  $N-2$  regions in the world, which themselves are influenced by the bilateral distances (and EIAs, etc.) of each of  $i$  and  $j$  with the other  $N-2$  regions. Bergstrand (1985) provided early empirical evidence of this omitted variables bias, but was limited by crude price-index data. As Feenstra (2004) reminds us, published price indexes probably do not reflect accurately “true” border costs (numerous costs associated with international

---

<sup>4</sup>In the remainder of the paper, boldfaced regular-case (non-bold italicized) variables denote observed (unobserved) variables.

<sup>5</sup>The traditional argument is as follows. Suppose importer  $j$ 's demand for the trade flow from  $i$  to  $j$  is a function of  $j$ 's GDP, the price of the product in  $i$  ( $p_i$ ), and distance from  $i$  to  $j$ . Suppose exporter  $i$ 's supply of goods is a function of  $i$ 's GDP and  $p_i$ . Market clearing would require country  $i$ 's export supply to equal the sum of the  $N-1$  bilateral import demands (in an  $N$ -country world). This generates a system of  $N+1$  equations in  $N+1$  endogenous variables:  $N-1$  bilateral import demands  $X_{ij}^D$  ( $j = 1, \dots, N$  with  $j \neq i$ ), supply variable  $X_i^S$ , and price variable  $p_i$ . This system could be solved for a bilateral trade flow equation for  $\mathbf{X}_{ij}$  that is a function of the GDPs of  $i$  and  $j$  and their bilateral distance. Then  $p_i$  is endogenous and excluded from the reduced-form bilateral trade flow gravity equation.

transactions) and are measured relative to an arbitrary base period.

A-vW raised two important considerations. First, A-vW showed theoretically that proper estimation of the coefficients of a theoretically-based gravity equation (such as  $\beta_5$ ) needs to account for the influence of these (nonlinear) endogenous price terms. One approach is NLLS estimation, and the other is the use of region-specific (i, j) fixed effects. Second, these techniques yield partial effects of change in a bilateral trade cost on a bilateral trade flow, but not *general-equilibrium* effects. A-vW clarified that the comparative-static effects of a change in a trade cost were influenced by the full general-equilibrium framework. Regardless of which of the two techniques above was used to estimate coefficient parameters, the comparative statics of a change in a trade cost require estimation of the full structural model (cf., footnote 2), which necessarily reflect economic sizes and trade costs of *all* countries.

#### A. The Theoretical Model

To understand the context, we initially describe a set of assumptions to derive a gravity equation; for analytical details, see A-vW (2003). First, assume a world endowment economy with N regions and N (aggregate) goods, each good differentiated by origin. Second, assume consumers in each region j have identical constant-elasticity-of-substitution (CES) preferences:

$$U_j = \left[ \sum_{i=1}^N C_{ij}^{(\sigma-1)/\sigma} \right]^{\sigma/(\sigma-1)} \quad j = 1, \dots, N \quad (2)$$

where  $U_j$  is the utility of consumers in region j,  $C_{ij}$  is consumption of region i's good in region j, and  $\sigma$  is the elasticity of substitution (assuming  $\sigma > 1$ ).<sup>6</sup> Maximizing (2) subject to the budget constraint:

$$Y_j = \sum_{i=1}^N p_i t_{ij} C_{ij} \quad (3)$$

where  $p_i$  is the exporter's price of region i's good and  $t_{ij}$  is the gross trade cost (one plus the *ad valorem* trade cost<sup>7</sup>) associated with exports from i to j, yields a set of first order conditions that can be solved for the demand for the nominal bilateral trade flow from i to j:

---

<sup>6</sup>Consumption is measured as a quantity. We can also set up the model in terms of a representative consumer with  $M_j$  consumers in each country, but the results are analytically identical.

<sup>7</sup>As conventional, we assume that all trade costs consume resources and can be interpreted as goods "lost in transit" (i.e., iceberg trade costs).

$$X_{ij} = \left( \frac{p_i t_{ij}}{P_j} \right)^{1-\sigma} Y_j \quad (4)$$

where  $P_j$  is the CES price index, given by:

$$P_j = \left[ \sum_{i=1}^N (p_i t_{ij})^{1-\sigma} \right]^{1/(1-\sigma)} \quad (5)$$

Third, an assumption of market clearing requires:

$$Y_i = \sum_{j=1}^N X_{ij} \quad (6)$$

Following A-vW, substitution of (4) and (5) into (6) and some algebraic manipulation yields:

$$X_{ij} = \left( \frac{Y_i Y_j}{Y^T} \right) \left( \frac{t_{ij}}{P_i P_j} \right)^{1-\sigma} \quad (7)$$

where

$$P_i = \left[ \sum_{j=1}^N \theta_j (t_{ij} / P_j)^{1-\sigma} \right]^{1/(1-\sigma)} \quad (8)$$

$$P_j = \left[ \sum_{i=1}^N \theta_i (t_{ij} / P_i)^{1-\sigma} \right]^{1/(1-\sigma)} \quad (9)$$

under a fourth assumption that bilateral trade barriers  $t_{ij}$  and  $t_{ji}$  are equal for all pairs.  $Y^T$  denotes total income of all regions, which is constant across region pairs, and  $\theta_i$  ( $\theta_j$ ) denotes  $Y_i / Y^T$  ( $Y_j / Y^T$ ).

### B. The Econometric Model

As is common to this literature, for an econometric model we assume the log of the observed trade flow ( $\ln X_{ij}$ ) is equal to the log of the true trade flow ( $\ln X_{ij}$ ) plus a log-normally distributed error term ( $\epsilon_{ij}$ ).  $Y_i$  can feasibly be represented empirically by observable **GDP**<sub>*i*</sub>. However, the world is not so generous as to provide observable measures of bilateral trade costs  $t_{ij}$ . Following the literature, a fifth assumption is that

the gross trade cost factor is a log-linear function of *observable* variables, such as bilateral distance ( $\mathbf{DIS}_{ij}$ ),  $e^{\delta \mathbf{ADJACENCY}_{ij}}$ , and  $e^{\alpha \mathbf{EIA}_{ij}}$ , the latter two representing the *ad valorem* equivalents of a common land border and a common EIA, respectively:

$$t_{ij} = \mathbf{DIS}_{ij}^{\rho} e^{\delta \mathbf{ADJACENCY}_{ij}} e^{\alpha \mathbf{EIA}_{ij}} \quad (10)$$

where  $e^{\delta \mathbf{ADJACENCY}_{ij}}$  equals  $e^{\delta}$  ( $> 1$ ) if the two regions share a common land border (assuming  $\delta > 0$ ) and  $e^{\alpha \mathbf{EIA}_{ij}}$  equals  $e^{\alpha}$  ( $> 1$ ) if the two regions are in an economic integration agreement (assuming  $\alpha > 0$ ). One could also include a language dummy, a bilateral tariff rate, etc.; for brevity, we ignore these.

In the McCallum-AvW-Feenstra context of Canadian provinces and U.S. states,  $\mathbf{EIA}_{ij} = 1$  if the two regions are in the same country and these studies ignored  $\mathbf{ADJACENCY}_{ij}$  (i.e., a common land border). In the context of the theory, estimation of the gravity equation's parameters should account for the multilateral (price) resistance terms defined in equations (8) and (9). A-vW describe one customized nonlinear procedure for estimating equations (7)-(10) to generate unbiased estimates in a two-country world with 10 Canadian provinces, 30 U.S. states and an aggregate rest-of-U.S. (the other 20 states plus the District of Columbia), or 41 regions total. A-vW also estimate a multicounty model, but discussion of that is treated later. This procedure requires minimizing the sum-of-squared residuals of:

$$\ln \left[ \mathbf{X}_{ij} / \left( \mathbf{GDP}_i \mathbf{GDP}_j \right) \right] = a_0 + a_1 \ln \mathbf{DIS}_{ij} + a_2 \mathbf{EIA}_{ij} - \ln P_i^{1-\sigma} - \ln P_j^{1-\sigma} + \varepsilon_{ij} \quad (11)$$

subject to the 41 market-equilibrium conditions:

$$P_1^{1-\sigma} = \sum_{i=1}^{41} P_i^{\sigma-1} \left( \mathbf{GDP}_i / \mathbf{GDP}^T \right) e^{a_1 \ln \mathbf{DIS}_{i1} + a_2 \mathbf{EIA}_{i1}} \quad (12.1)$$

$$\vdots$$

$$P_{41}^{1-\sigma} = \sum_{i=1}^{41} P_i^{\sigma-1} \left( \mathbf{GDP}_i / \mathbf{GDP}^T \right) e^{a_1 \ln \mathbf{DIS}_{i41} + a_2 \mathbf{EIA}_{i41}} \quad (12.41)$$

to estimate  $a_0$ ,  $a_1$ , and  $a_2$  where, in the model's context,  $a_0 = -\ln\mathbf{GDP}^T$ ,  $a_1 = -\rho(\sigma-1)$  and  $a_2 = -\alpha(\sigma-1)$ . This obviously requires a custom NLLS program.

### C. Estimating Comparative-Static Effects

As A-vW stress, the multilateral resistance terms  $P_i^{1-\sigma}$  and  $P_j^{1-\sigma}$  are “critical” to understanding the impact of border barriers on bilateral trade. Once estimates of  $a_0$ ,  $a_1$ , and  $a_2$  are obtained, one can then retrieve estimates of  $P_i^{1-\sigma}$  and  $P_j^{1-\sigma}$  for all  $j = 1, \dots, 41$  regions both in the presence and absence of a national border. Let  $\mathbf{P}_i^{1-\sigma}$  ( $\mathbf{P}_i^{*1-\sigma}$ ) denote the estimate of the multilateral resistance term of region  $i$  with (without) an EIA following NLLS estimation of equations (11) and (12.1)-(12.41). In the context of the model, A-vW and Feenstra (2004) both show that the ratio of bilateral trade between any two regions *with* an EIA ( $\mathbf{X}_{ij}$ ) and *without* an EIA ( $\mathbf{X}_{ij}^*$ ) is given by:

$$\mathbf{X}_{ij} / \mathbf{X}_{ij}^* = e^{a_2 \mathbf{EIA}_{ij}} \left( \mathbf{P}_i^{*1-\sigma} / \mathbf{P}_i^{1-\sigma} \right) \left( \mathbf{P}_j^{*1-\sigma} / \mathbf{P}_j^{1-\sigma} \right) \quad (13)$$

Comparative-static effects of an integration agreement are then calculated using equation (13). Clearly, the multilateral price terms with and without borders are critical to estimating these effects.

Consequently, A-vW (2003) “resolved” the border puzzle theoretically and empirically. However, the appealing characteristic of the gravity equation, that likely has contributed to its becoming the workhorse for the study of empirical trade patterns, is that it has been estimated for decades using OLS. The A-vW procedure cannot use OLS. This will likely inhibit future researchers from recognizing empirically the multilateral price terms, as suggested by van Wincoop in footnote 2.

A-vW (2003) and Feenstra (2004) both note that a ready alternative to estimating consistently the *average* border effect is to apply fixed effects. However, both studies also note that a fixed-effects approach cannot readily generate estimates of the comparative statics. Feenstra (2004) acknowledges that the fixed-effects approach is less efficient than A-vW's custom nonlinear estimation procedure; however, the former is simpler to estimate the average border effect. However, while fixed effects can determine gravity equation parameters consistently, estimation of country-specific border effects *still requires* construction of the structural system of price equations to distinguish multilateral resistance terms with *and* without borders. We demonstrate in the remainder of this paper that a simple OLS technique that yields virtually identical estimates of the average effects *and* comparative statics surfaces by applying a Taylor-series expansion to the theory.

### 3. Bonus Vetus OLS

In this section, we apply a first-order log-linear Taylor-series expansion to the system of price

equations above to generate a reduced-form gravity equation – including theoretically-motivated exogenous multilateral-and-world-resistance (MWR) terms – that can be estimated using OLS. A first-order Taylor-series expansion of any function  $f(x_i)$ , centered at  $x$ , is given by  $f(x_i) = f(x) + [f'(x)](x_i - x)$ . Of course, the Taylor-series expansion requires some arbitrary choice for  $x$ . In modern dynamic macroeconomics, where such expansions are common, the Taylor-series expansion is usually made around the steady-state value, suggested by the theoretical model.<sup>8</sup>

Since the solution to a Taylor-series expansion is sensitive to how it is “centered,” we consider two cases. In our static context, a natural choice is an expansion centered around a “symmetric” world, which we will solve in the second subsection. An empirically implausible – but theoretically feasible – case is a “frictionless” world (zero trade costs). First, we derive an OLS model assuming the world is frictionless. Despite a restrictive setting, the solution under this simpler scenario illustrates some fundamental insights about specifying theoretically-motivated “exogenous” multilateral-and-world-resistance terms and illustrates the essence of our approach. Second, since the real world is far from frictionless, we derive the expansion also centered around a “symmetric” world in (positive) trade costs and incomes.<sup>9</sup> This assumption may be more conceptually appropriate since OLS estimation defines variables as deviations around their “mean” values; hence, we associate centering around a “symmetric” equilibrium with centering around the “means.” Moreover, we show later in sections 4, 5, and 6 why such an assumption is very useful to generate OLS-based estimates of gravity equation parameters and comparative-static effects that are consistently *virtually identical* to those using A-vW’s custom NLLS approach. The basic intuition is that, in the second case, much of the dispersion of incomes can be accounted for by an intercept.

We begin with  $N$  equations (8) from Section 2:

$$P_i = \left[ \sum_{j=1}^N \theta_j \left( t_{ij} / P_j \right)^{1-\sigma} \right]^{1/(1-\sigma)} \quad (8)$$

for  $i = 1, \dots, N$ . It will be useful for later to rewrite (8) as:

$$e^{(1-\sigma)\ln P_i} = \sum_{j=1}^N e^{\ln \theta_j} e^{(\sigma-1)\ln P_j} e^{(1-\sigma)\ln t_{ij}} \quad (14)$$

---

<sup>8</sup>We find that a first-order Taylor series works well, using a Monte Carlo robustness analysis. Higher-order terms are largely unnecessary but would reduce the remaining small bias; we address this more in section 7.

<sup>9</sup>That is, every region faces the same trade costs with every other region and is identically sized.

where  $e$  is the natural logarithm operator.

#### A. Case 1: Derivations for a Frictionless World

In a frictionless world, we are assuming  $t_{ij} = t = 1$  for all  $i, j = 1, \dots, N$ . Hence, equation (8) simplifies to:

$$P_i^{1-\sigma} = \sum_{j=1}^N \theta_j P_j^{\sigma-1} \quad (15)$$

for all  $i = 1, \dots, N$ . Multiplying both sides of equation (15) by  $P_i^{\sigma-1}$  yields:

$$1 = \sum_{j=1}^N \theta_j (P_i P_j)^{\sigma-1} \quad (16)$$

As noted in Feenstra (2004, p. 158, footnote 11), the solution to equation (16) is:

$$P_i = P = 1 \quad (17)$$

for all  $i = 1, \dots, N$ . Note that  $\theta_j$  can vary across  $N$  countries in this case.

Consequently, a first-order log-linear Taylor-series expansion of equation (14) centered at  $P = t = 1$  (and  $\ln P = \ln t = 0$ ) is:

$$1 + \ln P_i^{1-\sigma} = 1 - \sum_{j=1}^N \theta_j \ln P_j^{1-\sigma} + (1-\sigma) \sum_{j=1}^N \theta_j \ln t_{ij} \quad (18)$$

using  $d[e^{(1-\sigma)\ln P}]/d(\ln P) = (1-\sigma)e^{(1-\sigma)\ln P}$ . Subtracting 1 from both sides, multiplying both sides by  $\theta_i$ , and summing both sides over  $N$  yields:

$$\sum_{i=1}^N \theta_i \ln P_i^{1-\sigma} = -\sum_{i=1}^N \theta_i \sum_{j=1}^N \theta_j \ln P_j^{1-\sigma} + (1-\sigma) \sum_{i=1}^N \sum_{j=1}^N \theta_i \theta_j \ln t_{ij} \quad (19)$$

Noting that the first RHS term can be expressed in alternative ways,

$$-\sum_{i=1}^N \theta_i \sum_{j=1}^N \theta_j \ln P_j^{1-\sigma} = -\sum_{j=1}^N \theta_j \ln P_j^{1-\sigma} = -\sum_{i=1}^N \theta_i \ln P_i^{1-\sigma}$$

we can substitute  $-\sum_{i=1}^N \theta_i \ln P_i^{1-\sigma}$  for  $-\sum_{i=1}^N \theta_i \sum_{j=1}^N \theta_j \ln P_j^{1-\sigma}$  in equation (19) to yield:

$$\sum_{i=1}^N \theta_i \ln P_i^{1-\sigma} = -\sum_{j=1}^N \theta_j \ln P_j^{1-\sigma} + (1-\sigma) \sum_{i=1}^N \sum_{j=1}^N \theta_i \theta_j \ln t_{ij}$$

or

$$\sum_{i=1}^N \theta_i \ln P_i^{1-\sigma} = \sum_{j=1}^N \theta_j \ln P_j^{1-\sigma} = (1/2)(1-\sigma) \sum_{i=1}^N \sum_{j=1}^N \theta_i \theta_j \ln t_{ij} \quad (20)$$

Substituting equation (20) into equation (18), after subtracting 1 from both sides of eq. (18), yields:

$$\ln P_i^{\sigma-1} = -\ln P_i^{1-\sigma} = (\sigma-1) \left[ \sum_{j=1}^N \theta_j \ln t_{ij} - (1/2) \sum_{i=1}^N \sum_{j=1}^N \theta_i \theta_j \ln t_{ij} \right] \quad (21)$$

and it follows that:

$$\ln P_j^{\sigma-1} = -\ln P_j^{1-\sigma} = (\sigma-1) \left[ \sum_{i=1}^N \theta_i \ln t_{ji} - (1/2) \sum_{i=1}^N \sum_{j=1}^N \theta_i \theta_j \ln t_{ij} \right] \quad (22)$$

Although (by assumption)  $t_{ij} = t_{ji}$ ,  $\sum_{i=1}^N \theta_i \ln t_{ij}$  need not equal  $\sum_{j=1}^N \theta_j \ln t_{ij}$ .<sup>10</sup>

Equations (21) and (22) are critical to understanding this analysis. The benefit of the first-order log-linear expansion is that it identifies the *exogenous* factors determining the multilateral price terms in equation (7) in a manner consistent with the theoretical model. To understand the intuition behind equation (22) – analogous for (21) – we consider separately each of the two components of the RHS. The first component is a GDP-share-weighted (geometric) average of the gross trade costs facing country  $j$  across all regions. The higher this average, the greater overall multilateral resistance in  $j$ . Holding constant bilateral determinants of trade, the larger is  $j$ 's multilateral resistance, the lower are bilateral trade costs relative to multilateral trade costs. Hence, the *larger* the bilateral trade flow from  $i$  to  $j$  will be. The analogous intuition applies to equation (21).

Now consider the second component on the RHS of equation (22). The Taylor-series expansion here makes transparent the influence of *world resistance*, which is identical for all countries. In A-vW, this second component is only implicit. World resistance lowers trade between *every* pair of countries. This term is constant in cross-section gravity estimation, embedded in and affecting only the intercept.

---

<sup>10</sup>For instance, internal distances  $t_{ii}$  and  $t_{jj}$  will likely differ, as will  $\theta_i$  and  $\theta_j$ . For transparency and consistency with A-vW's notation, we note that  $\ln P_i^{\sigma-1} = -\ln P_i^{1-\sigma}$ ; analogously for  $j$ .

(However, the term cannot be ignored in estimating “border effects.”)<sup>11</sup> Together, these terms indicate that the level of bilateral trade from  $i$  to  $j$  is influenced – not just by the level of *bilateral relative to multilateral* trade costs, but also – by *multilateral relative to world* trade costs. Our estimation can account for the role of world resistance.

In the context of the theory just discussed, we can obtain consistent estimates of the gravity equations’ coefficients – accounting for the endogenous multilateral price variables – by estimating *using OLS* the reduced-form gravity equation:

$$\begin{aligned} \ln X_{ij} = & \beta_0' + \ln \mathbf{GDP}_i + \ln \mathbf{GDP}_j - (\sigma - 1) \ln t_{ij} \\ & + (\sigma - 1) \left[ \left( \sum_{j=1}^N \theta_j \ln t_{ij} \right) - \frac{1}{2} \left( \sum_{i=1}^N \sum_{j=1}^N \theta_i \theta_j \ln t_{ij} \right) \right] \\ & + (\sigma - 1) \left[ \left( \sum_{i=1}^N \theta_i \ln t_{ji} \right) - \frac{1}{2} \left( \sum_{i=1}^N \sum_{j=1}^N \theta_i \theta_j \ln t_{ij} \right) \right] \end{aligned} \quad (23)$$

where  $\beta_0' = -\ln Y^T$  is a constant across country pairs. Thus, in the context of the theoretical model, the influence of the endogenous multilateral price variables can be accounted for, once we have measures of  $t_{ij}$ , using *theoretically-motivated exogenous* multilateral resistance variables. This is the first major result of this paper.

We close this section noting that it will be useful now to exponentiate equation (23). After some algebra, this yields:

$$\frac{X_{ij}}{Y_i Y_j / Y^T} = \left( \frac{t_{ij}}{t_i(\theta) t_j(\theta) / t^T(\theta)} \right)^{-(\sigma-1)} \quad (24)$$

where  $t_i(\theta) = \prod_{j=1}^N t_{ij}^{\theta_j}$ ,  $t_j(\theta) = \prod_{i=1}^N t_{ji}^{\theta_i}$ ,  $t^T(\theta) = \prod_{i=1}^N \prod_{j=1}^N t_{ij}^{\theta_i \theta_j}$ , and recall  $\theta_i = Y_i / Y^T$  and  $t_{ij} = t_{ji}$  (by assumption). BV-OLS significantly simplifies the gravity equation implied by equations (7)-(9). Based upon a first-order log-linear expansion of the A-vW model, equation (24) is a simple reduced-form

---

<sup>11</sup>Moreover, in panel estimation, changes in world resistance over time – along with changes in world income – provide a rationale for including a time trend.

equation capturing the theoretical influences of bilateral, multilateral, and world trade costs on (relative) bilateral trade. As noted, multilateral-and-world-trade costs are GDP-share weighted. Given data on bilateral trade flows, national incomes, and bilateral trade costs, equation (24) can be estimated by “good old OLS,” noting the possible endogeneity bias introduced by GDP-share weights in RHS variables.<sup>12</sup> But will this equation work *empirically*?

At this juncture, we ask *four* critical questions that guide the direction of the remainder of our paper. First, does centering the Taylor expansion around a *frictionless* equilibrium make economic and/or econometric sense, or is there a more plausible alternative? Second, does BV-OLS estimation *work* empirically as an approximation to A-vW (allowing for measurement and specification error), and *why*? Third, using Monte Carlo analysis to eliminate measurement and specification errors, does BV-OLS *work well*? Fourth, if the linear approximation of BV-OLS works well, *why* does it work well?

The next sub-section (3B) addresses the first question. Sections 4 and 5 address the second set of questions. Finally, sections 6 and 7 address the third and fourth questions, respectively.

### B. Case 2: Derivations for a Symmetric World

The world is far from frictionless. Yet, a Taylor-series expansion requires *some* “center.” An alternative center would be a *symmetric* world – where countries have identical economic (GDP) sizes ( $\theta_j = 1/N$ ) and trade costs ( $t_{ij} = t$ ), but the latter are positive ( $t > 1$ ) unlike the previous case. One can interpret the centering around a symmetric equilibrium as centering around the “means” of GDP shares and trade costs. This has a ready econometric analogue when the resulting trade-flow equation is estimated by OLS with cross-sectional data since OLS coefficients correspond to variables that are defined as deviations around their respective “means.” We now show that a gravity equation similar to equation (24) surfaces under this centering that can potentially yield virtually identical coefficient estimates to those generated by NLLS structural estimation.

In a symmetric world, equation (8) can be expressed as:

$$P^{1-\sigma} = N\theta P^{\sigma-1} t^{1-\sigma} \quad (25)$$

where  $P$  denotes the multilateral price term under symmetry. It will be useful to note now that (25) can be solved for  $P$  as a function of  $N$ ,  $\theta$ , and  $t$ :

$$P = (N\theta)^{1/[2(1-\sigma)]} t^{1/2} = t^{1/2} \quad (26)$$

---

<sup>12</sup>We ignore here the possibility of “zero” trade flows. Such issues have been dealt with by various means; see, for example, Felbermayr and Kohler (2004).

since  $\theta = 1/N$  in a symmetric world.

A first-order log-linear Taylor-series expansion of equation (14) is:

$$\begin{aligned}
& P^{1-\sigma} + (1-\sigma)P^{1-\sigma}(\ln P_i - \ln P) \\
&= \sum_{j=1}^N \left[ \theta P^{-(1-\sigma)} t^{1-\sigma} - (\theta P^{-(1-\sigma)} t^{1-\sigma})(1-\sigma)(\ln P_j - \ln P) \right. \\
&\quad \left. + (\theta P^{-(1-\sigma)} t^{1-\sigma})(\ln \theta_j - \ln \theta) + (\theta P^{-(1-\sigma)} t^{1-\sigma})(1-\sigma)(\ln t_{ij} - \ln t) \right] \\
&= (P^{1-\sigma}/N) \sum_{j=1}^N \left[ 1 - (1-\sigma)(\ln P_j - \ln P) + (\ln \theta_j - \ln \theta) + (1-\sigma)(\ln t_{ij} - \ln t) \right]
\end{aligned} \tag{27}$$

using equation (25) and  $d[e^{(1-\sigma)\ln P}]/d(\ln P) = (1-\sigma)e^{(1-\sigma)\ln P}$ . Dividing both sides of (27) by

$P^{1-\sigma}$  yields:

$$\begin{aligned}
(1-\sigma)(\ln P_i - \ln P) &= -(1-\sigma)N^{-1} \sum_{j=1}^N (\ln P_j - \ln P) \\
&\quad + N^{-1} \sum_{j=1}^N (\ln \theta_j - \ln \theta) + (1-\sigma)N^{-1} \sum_{j=1}^N (\ln t_{ij} - \ln t) \\
&= -(1-\sigma)N^{-1} \sum_{j=1}^N \ln P_j + N^{-1} \sum_{j=1}^N \ln \theta_j + (1-\sigma)N^{-1} \sum_{j=1}^N \ln t_{ij} \\
&\quad + (1-\sigma) \ln P - \ln \theta - (1-\sigma) \ln t
\end{aligned} \tag{28}$$

Using (25), add  $(1-\sigma) \ln P = \ln N + \ln \theta - (1-\sigma) \ln P + (1-\sigma) \ln t$  to (28) to yield:

$$\ln P_i^{1-\sigma} = \ln N - N^{-1} \sum_{j=1}^N \ln P_j^{1-\sigma} + N^{-1} \sum_{j=1}^N \ln \theta_j + (1-\sigma)N^{-1} \sum_{j=1}^N \ln t_{ij} \tag{29}$$

To solve for  $\ln P_i^{1-\sigma}$ , sum both sides of equation (29) over  $i = 1, \dots, N$ :

$$\begin{aligned} \sum_{i=1}^N \ln P_i^{1-\sigma} &= N \ln N - NN^{-1} \sum_{j=1}^N \ln P_j^{1-\sigma} \\ &+ NN^{-1} \sum_{j=1}^N \ln \theta_j + (1-\sigma)N^{-1} \sum_{i=1}^N \sum_{j=1}^N \ln t_{ij} \end{aligned} \quad (30)$$

Since  $\sum_{i=1}^N \ln P_i^{1-\sigma} = \sum_{j=1}^N \ln P_j^{1-\sigma}$  then (30) simplifies to:

$$\sum_{j=1}^N \ln P_j^{1-\sigma} = \frac{1}{2} N \ln N + \frac{1}{2} \sum_{j=1}^N \ln \theta_j + \frac{1}{2} (1-\sigma) N^{-1} \sum_{i=1}^N \sum_{j=1}^N \ln t_{ij} \quad (31)$$

Substituting (31) for  $\sum_{j=1}^N \ln P_j^{1-\sigma}$  in (29) yields:

$$\begin{aligned} \ln P_i^{\sigma-1} = -\ln P_i^{1-\sigma} &= (\sigma-1) \left[ \frac{1}{N} \left( \sum_{j=1}^N \ln t_{ij} \right) - \frac{1}{2} \frac{1}{N^2} \left( \sum_{i=1}^N \sum_{j=1}^N \ln t_{ij} \right) \right] \\ &- \frac{1}{2} \left[ \frac{1}{N} \left( \sum_{j=1}^N \ln \theta_j \right) - \ln \left( \frac{1}{N} \right) \right] \end{aligned} \quad (32)$$

and, by implication:

$$\begin{aligned} \ln P_j^{\sigma-1} = -\ln P_j^{1-\sigma} &= (\sigma-1) \left[ \frac{1}{N} \left( \sum_{i=1}^N \ln t_{ji} \right) - \frac{1}{2} \frac{1}{N^2} \left( \sum_{i=1}^N \sum_{j=1}^N \ln t_{ij} \right) \right] \\ &- \frac{1}{2} \left[ \frac{1}{N} \left( \sum_{j=1}^N \ln \theta_j \right) - \ln \left( \frac{1}{N} \right) \right] \end{aligned} \quad (33)$$

Equations (32) and (33) are similar to equations (21) and (22), but share two key distinctions. First, since this derivation allows an expansion around  $\theta_j$ , additional terms are present in both equations reflecting deviations around identical GDP shares ( $1/N$ ). Second, because of this additional expansion, the trade cost terms are *simple* averages – rather than GDP-share-weighted averages – of the logs of the  $t_{ij}$ 's

since the dispersion of incomes is treated separately.

The second bracketed RHS term (second line) in either equation (32) or (33) represents deviations of GDP shares around symmetry. If all regions are the same size in GDP, this last term is zero. The more GDP shares deviate from symmetry, the higher is multilateral resistance and the *greater* the bilateral trade flow. The intuition parallels that of GDPs of exporter  $i$  and importer  $j$  in the standard gravity equation, such as equation (7). For given economic size of two regions, bilateral trade is diminished the more asymmetric in size are regions  $i$  and  $j$ . Similarly here, the greater the asymmetry in all regions' economic sizes, the smaller will be multilateral trade of any particular country.<sup>13</sup> Holding bilateral determinants constant, bilateral trade from  $i$  to  $j$  will be greater the more asymmetric are *all* regions' economic sizes.

Centering on a symmetric world, we can obtain estimates of the gravity equations' coefficients accounting for multilateral resistance by estimating using OLS the gravity equation:

$$\begin{aligned} \ln \mathbf{X}_{ij} = & \beta_0' + \ln \mathbf{GDP}_i + \ln \mathbf{GDP}_j - (\sigma - 1) \ln t_{ij} \\ & + (\sigma - 1) \left[ \frac{1}{N} \left( \sum_{j=1}^N \ln t_{ij} \right) - \frac{1}{2} \frac{1}{N^2} \left( \sum_{i=1}^N \sum_{j=1}^N \ln t_{ij} \right) \right] \\ & + (\sigma - 1) \left[ \frac{1}{N} \left( \sum_{i=1}^N \ln t_{ji} \right) - \frac{1}{2} \frac{1}{N^2} \left( \sum_{i=1}^N \sum_{j=1}^N \ln t_{ij} \right) \right] \end{aligned} \quad (34)$$

where  $\beta_0' = -\ln Y^T - \left[ \frac{1}{N} \left( \sum_{j=1}^N \ln \theta_j \right) - \ln \left( \frac{1}{N} \right) \right]$  is a constant across country pairs. Thus, in the context of the theoretical model, the influence of the endogenous multilateral price variables can be accounted for using slightly different *theoretically-motivated exogenous* multilateral resistance variables.<sup>14</sup>

---

<sup>13</sup>Asymmetry in GDP shares across all bilateral partners (which causes the second bracketed term to become negative) raises multilateral resistance, analogous to the traditional gravity equation notion that greater asymmetry in bilateral GDP shares increases bilateral trade resistance, cf., Baier and Bergstrand (2001).

<sup>14</sup>In estimation of equation (34), the second component of each multilateral resistance term is constant across country pairs, and thus only influences the estimate of the intercept. However, we leave these "world-resistance" terms in each multilateral resistance term because they will be important in estimating later "border effects." Indeed, the variables measuring GDP-share asymmetries are also important theoretically for estimating border effects, but – as in A-vW – we will ignore these later in estimating border effects because they will be

As in the previous section, exponentiating equation (34) yields the analogue to equation (24). In the context of an N-region world, the log-linear approximation of the general equilibrium model yields the simple reduced-form gravity equation :

$$\frac{X_{ij}}{Y_i Y_j / Y^T} = \theta \left( \frac{t_{ij}}{t_i t_j / t^T} \right)^{-(\sigma-1)} \quad (35)$$

where  $\theta = \left( N \prod_{j=1}^N \theta_j^{1/N} \right)^{-1}$ ,  $t_i = \prod_{j=1}^N t_{ij}^{1/N}$ ,  $t_j = \prod_{i=1}^N t_{ji}^{1/N}$ ,  $t^T = \prod_{i=1}^N \prod_{j=1}^N t_{ij}^{1/N^2}$ , and recall  $t_{ij} = t_{ji}$  (by assumption).

Compare equations (24) and (35). The latter differs from the former in one critical dimension. In equation (35), the effect of dispersion of GDPs is accounted for entirely in the first term on the RHS and affects only the intercept; dispersion of GDPs is captured in  $\theta$ . The Taylor expansion around GDP shares effectively removes the GDP-share weights from the multilateral and world trade cost variables. By implication, the RHS term in brackets is a function of *exogenous* (trade cost) variables. This reduces the influence of dispersion of economic mass on estimates of key parameters, such as the effect of trade costs – including borders – on trade flows,  $-(\sigma-1)$ . Consequently, we expect OLS estimation of equation (34) – BV-OLS centered around a symmetric equilibrium – to yield closer estimates to the “true” parameters than OLS estimation of (23).<sup>15</sup>

The preceding discussion addresses the first question asked at the end of section 3A: Does centering the Taylor expansion around a frictionless world make economic sense, or is there a better alternative? This section argued that centering around a symmetric world seems more plausible economically and econometrically. The second question posed at the end of section 3A was: Does BV-OLS estimation *work* empirically as an approximation to A-vW (allowing for measurement and specification error)? Sections 4 below address this question.

#### 4. BV-OLS Works: Estimation of Average Effects

The goal of this section is to show that one can generate virtually identical gravity equation coefficient estimates (“average effects”) to those generated using the technique in A-vW but using instead

---

quantitatively trivial and it will facilitate estimation of such effects.

<sup>15</sup>In fact, while for brevity we do not report estimates for equation (23), both econometric and simulation results confirm this argument. Results are available on request. Note also that (to deal with “zero” trade flows) equation (35) can potentially be estimated using a pseudo Poisson maximum likelihood procedure with an additive error term.

OLS with exogenous multilateral-resistance terms determined by theory. While the approach should work in numerous contexts, for tractability for the reader we apply it in this paper to McCallum's U.S.-Canadian case, since this is a popular context; in a later section, we also do a Monte Carlo analysis for world trade flows among countries. We estimate the McCallum, A-vW, fixed-effects, and our versions of the model using the A-vW data provided at Robert Feenstra's website, and compare our coefficient estimates with the other results. We show that A-vW, fixed effects, and our methods can yield virtually identical gravity-equation coefficient estimates, even though both BV-OLS and fixed effects are computationally simpler.

Before estimating (34), we need to replace the unobservable theoretical trade-cost variable  $t_{ij}$  in (34) with an observable variable. First, we will define a dummy variable, **BORDER**<sub>ij</sub>, which assumes a value of 1 if regions *i* and *j* are *not* in the same nation; hence, **EIA**<sub>ij</sub> = 1 - **BORDER**<sub>ij</sub>.<sup>16</sup> Take the logarithms of both sides of equation (10) and then substitute the resulting equation for  $\ln t_{ij}$  into (34) to yield:

$$\begin{aligned} \ln \mathbf{x}_{ij} = & \beta_0' - \rho(\sigma - 1) \ln \mathbf{DIS}_{ij} - \alpha(\sigma - 1) \mathbf{BORDER}_{ij} \\ & + \rho(\sigma - 1) \mathbf{MWRDIS}_{ij} + \alpha(\sigma - 1) \mathbf{MWRBORDER}_{ij} + \varepsilon_{ij} \end{aligned} \quad (36)$$

where

$$\mathbf{MWRDIS}_{ij} = \left[ \frac{1}{N} \left( \sum_{j=1}^N \ln \mathbf{DIS}_{ij} \right) + \frac{1}{N} \left( \sum_{i=1}^N \ln \mathbf{DIS}_{ij} \right) - \frac{1}{N^2} \left( \sum_{i=1}^N \sum_{j=1}^N \ln \mathbf{DIS}_{ij} \right) \right] \quad \text{and} \quad (37)$$

$$\mathbf{MWRBORDER}_{ij} = \left[ \frac{1}{N} \left( \sum_{j=1}^N \mathbf{BORDER}_{ij} \right) + \frac{1}{N} \left( \sum_{i=1}^N \mathbf{BORDER}_{ij} \right) - \frac{1}{N^2} \left( \sum_{i=1}^N \sum_{j=1}^N \mathbf{BORDER}_{ij} \right) \right] \quad (38)$$

where  $\mathbf{x}_{ij} = \mathbf{X}_{ij} / \mathbf{GDP}_i \mathbf{GDP}_j$ . We will term this the "BV-OLS" model, noting that – to conform to our theory – the coefficient estimates for  $\ln \mathbf{DIS}$  (**BORDER**) and  $\mathbf{MWRDIS}$  (**MWRBORDER**) are restricted to have identical but oppositely-signed coefficient values. "MWR" denotes Multilateral and World Resistance.

As readily apparent, equation (36) can be estimated straightforwardly using OLS, once data on

---

<sup>16</sup>It will be useful now to distinguish "regions" from "countries." We assume that a country is composed of regions (which, for empirical purposes later, can be considered states or provinces). We will assume *N* regions in the world and *n* countries, with *N* > *n*. Our theoretical model applies to a two-country or multi-country (*n* > 2) world. We will assume *n* ≥ 2. A "border" separates countries. Also, we use **BORDER** rather than **EIA** so that the coefficient estimates for **DIS** and **BORDER** are both negative and therefore are consistent with A-vW (2003) and Feenstra (2004). The model is isomorphic to being recast in a monopolistically-competitive framework.

trade flows, GDPs, bilateral distances, and borders are provided. We note that the inclusion of these additional MWR terms appears reminiscent of early attempts to include – what A-vW term – “atheoretical remoteness” variables, typically GDP-weighted averages of each country’s distance from all of its trading partners. However, there are three important differences here. First, our additional (the last two) terms are motivated by theory; moreover, we make explicit the role of *world* resistance. Second, in the context of our Taylor series around a symmetric equilibrium, the distances of each country from all of its trading partners should *not* be weighted by GDP shares.<sup>17</sup> Third, previous atheoretical remoteness measures included only multilateral *distance*, ignoring multilateral (and world) “border” variables (and multilateral and world resistance versions of other “bilateral” variables, such as adjacency, language, etc.).

We follow the A-vW procedure (for the two-country model) of estimating the gravity equation for trade flows among 10 Canadian provinces, 30 U.S. states, and one aggregate region representing the other 20 U.S. states and the District of Columbia (denoted RUS). As in A-vW, we do not include trade flows internal to a state or province. We calculate the distance between the aggregate U.S. region and the other regions in the same manner as A-vW. We also compute and use the *internal distances* as described in A-vW for **MWRDIS**. Hence, there are 41 regions. Some trade flows are zero and, as in A-vW, these are omitted. As in A-vW and Feenstra (2004), we have 1511 observations for trade flows from year 1993.

Table 1 provides the results. For purposes of comparison, column (1) of Table 1 provides the benchmark model (McCallum) results estimating equation (36) except *omitting* **MWRDIS** and **MWRBORDER**. Columns (2) and (3) provide the model estimated using NLLS as in A-vW for the two-country and multi-country cases, respectively. Column (4) provides the results from estimating equation (36) using BV-OLS. For completeness, column (5) provides the results from estimating equation (36) using region fixed effects instead of **MWRDIS** and **MWRBORDER**.

Table 1’s results are generally comparable to Table 2 in A-vW. Column (1)’s coefficient estimates for the basic McCallum regression, ignoring multilateral resistance terms, are biased, as expected. This specification can be compared with Feenstra (2004, Table 5.2, column 3), since it uses US-US, CA-CA, and US-CA data for 1993. Note, however, we report the border dummy’s coefficient estimate (“Indicator border”) whereas Feenstra reports instead the implied “Country Indicator” estimates.<sup>18</sup> Columns (2) and

---

<sup>17</sup>However, as shown earlier, these terms would include the GDP-share-weighted average distances if we centered our first-order log-linear approximation around a “frictionless” equilibrium.

<sup>18</sup>In Feenstra’s Table 5.2, column 3, he does not report the actual dummy variable’s coefficient estimate (comparable to our estimate of 0.71). Instead, he reports only the implied “Indicator Canada” and “Indicator US” estimates of 2.75 and 0.40, respectively. The implied Indicator Canada and Indicator US estimates from our regression are 2.66 and 0.48, respectively; the difference is that we restrict the GDP elasticities to unity. When we

(3) in Table 1 report the estimates (using *GAUSS*) of the A-vW benchmark coefficient estimates; these correspond exactly to those in A-vW's Table 2 and (for the two-country case) Feenstra's Table 5.2, column (4). The coefficient estimates from our BV-OLS specification (36) are reported in column (4) of Table 1. While the coefficient estimates differ from the NLLS estimates in columns (2) and (3), they match closely the coefficient estimates using fixed effects in column (5). Recall that – as both A-vW and Feenstra note – fixed effects should provide unbiased coefficient estimates of the bilateral distance and bilateral border effects, accounting fully for multilateral-resistance influences. Our column (5) estimates match exactly those in A-vW and Feenstra (2004).<sup>19</sup>

We now address the difference between bilateral distance coefficient estimates in columns (2) and (3) and those in columns (4) and (5). While Feenstra (2004) omitted addressing this difference, A-vW did address it in their sensitivity analysis (2003, part V, Table 6). As A-vW (2003, p. 188) note, the bilateral distance coefficient estimate using their NLLS program is quite sensitive to the calculation of “internal distances.” In their sensitivity analysis, they provide alternative coefficient estimates when the internal distance variable values are doubled (or, 0.5 minimum capitals' distance). These are reported in column (6) of our Table 1; note that the absolute value of the distance coefficient increases with virtually no change in the border dummy's coefficient estimate. Using the same procedure, we increased the internal distance variables' values by a factor of ten (or, 2.5 times minimum capitals' distance); the coefficient estimates are reported in Table 1, column (7). We see that the bilateral distance coefficient estimate is now much closer to those in columns (4) and (5).

These results confirm A-vW's suspicion that the NLLS estimation technique is sensitive to both measurement error in internal distances and potential specification error. Fixed-effects estimates, of course, do not depend on internal distance measures. The empirical results suggest that the (log-linear) BV-OLS estimation procedure avoids the potential bias introduced by measurement error and potential specification error better than the nonlinear estimation procedure. First, BV-OLS estimates are insensitive to measures of internal distance. As A-vW note (p. 179), internal distances are only relevant to calculating the multilateral resistance terms (in our context, only the multilateral and world resistance (MWR) terms). Examine equations (36) and (37) closely. Since the BV-OLS **MWRDIS** variable is linear in logs of distance, a doubling of internal distance simply alters the intercept of equation (36). The measurement error introduced by internal distances in A-vW's structural estimation is avoided in BV-OLS and fixed-

---

relax the constraints on GDP elasticities, our estimates match those in Feenstra's Table 5.2, column 3 and A-vW's Table 1 exactly.

<sup>19</sup>The coefficient estimates from the fixed-effects regression in A-vW's Table 6, column (viii) are not reported. However, they were generously provided by Eric van Wincoop in e-mail correspondence, along with the other coefficient estimates associated with their Table 6. A-vW's Distance (Border) coefficient estimate using fixed effects was -1.25 (-1.54).

effects estimation. Second, BV-OLS avoids potential specification bias, such as one raised by Balistreri and Hillberry (2004). That study argued that A-vW's NLLS estimates ignored the constraint that the constant ( $a_0$ ) needed to equal (the negative of the log of) world income; once this structural constraint is imposed, the A-vW coefficient estimates (especially that for distance) are closer to the fixed-effects estimates. By contrast, BV-OLS and fixed effects avoid this specification error.<sup>20</sup>

## 5. Why BV-OLS Works: Estimation of Comparative-Static Effects and Intuition

This section has three parts. In section A, we use BV-OLS to estimate comparative statics without the nonlinear system of equations. In section B, we provide intuition for why BV-OLS works in providing a good approximation of the comparative-static (average) *country* effects addressed in A-vW (2003). Yet, the multilateral resistance terms from BV-OLS are derived from linear “approximations”; consequently, MR terms estimated using BV-OLS are not likely to provide very precise estimates of region-specific or region-pair-specific comparative statics. Accordingly, in section C, we describe briefly a simple “fixed-point iteration” procedure that can be used to generate the *identical* MR terms and comparative statics as in A-vW, but again without the complex NLLS estimation procedure.

### A. Estimation of Comparative Statics using BV-OLS

As A-vW note and Feenstra (2004, p. 161) emphasizes, consistent estimates of the gravity equation coefficients and the *average* border effect can be obtained estimating eq. (1) adding region-specific fixed effects. However, to estimate the *country-specific* border effects, the fixed-effects technique falls short. As A-vW note, one still needs to use the coefficient estimates from column (5) in Table 1 along with the nonlinear system of equations (12.1)-(12.41) to generate the country-specific border effects. By contrast, the BV-OLS procedure allows one to estimate the country-specific border effects *without* employing the nonlinear system of equations. We now demonstrate this.<sup>21</sup>

---

<sup>20</sup>Our Taylor-series expansion illustrates that the intercept also reflects world resistance and the dispersion of world income. We note that Balistreri and Hillberry (2004) addressed other concerns about the A-vW study as well, including A-vW's exclusion of interstate trade flows and their imposing symmetry on U.S.-Canadian border effects. Due to space limitations, we do not address these issues.

<sup>21</sup> The discerning reader will note that the last two bracketed terms on the RHS of equation (36) effectively “de-mean” the  $\ln\text{DIS}_{ij}$  and  $\text{BORDER}_{ij}$  variables. Of course, estimation with region-specific fixed effects is equivalent econometrically to de-meaning  $\ln\text{DIS}_{ij}$  and  $\text{BORDER}_{ij}$ . However, BV-OLS is distinguished from fixed effects estimation in three dimensions. First, while fixed-effects dummy variables can “account” for variation in MR terms in estimation, such dummies cannot identify the source of multilateral resistance; BV-OLS can. Second, ideally the Taylor-series expansion should include higher-order terms, which would cause the MWR terms in BV-OLS to include variables other than just the means; the similarity to fixed effects is due to a first-order expansion. Third, econometrically BV-OLS is not identical to fixed effects because the LHS variable in BV-OLS,  $x_{ij}$ , is not de-meaned. This will cause BV-OLS estimates to differ from fixed effects. The distinction between BV-OLS and fixed-effects results is also confirmed empirically by noting the correlation coefficient between the MWR terms in

Recall equation (13) to calculate (region-specific) border effects for  $\mathbf{x}_{ij}$ , using its log-linear form:

$$\mathbf{BB}_{ij} = \ln \mathbf{x}_{ij} - \ln \mathbf{x}_{ij}^* = a_2 - \ln \mathbf{P}_i^{1-\sigma} + \ln \mathbf{P}_i^{*1-\sigma} - \ln \mathbf{P}_j^{1-\sigma} + \ln \mathbf{P}_j^{*1-\sigma} \quad (39)$$

where  $a_2$  is the estimate of  $-\alpha(\sigma-1)$  and  $a_2 < 0$ . We substitute equation (10) into equations (32) and (33) to find estimates of the multilateral price terms with *and* without national borders:

$$\begin{aligned} \ln \mathbf{P}_i^{1-\sigma} &= \frac{1}{2} \left[ \frac{1}{N} \sum_{j=1}^N \ln(\mathbf{GDP}_j / \mathbf{GDP}^T) - \ln\left(\frac{1}{N}\right) \right] \\ &+ a_2 \left[ \frac{1}{N} \left( \sum_{j=1}^N \mathbf{BORDER}_{ij} \right) - \frac{1}{2} \frac{1}{N^2} \left( \sum_{i=1}^N \sum_{j=1}^N \mathbf{BORDER}_{ij} \right) \right] \\ &+ a_1 \left[ \frac{1}{N} \left( \sum_{j=1}^N \ln \mathbf{DIS}_{ij} \right) - \frac{1}{2} \frac{1}{N^2} \left( \sum_{i=1}^N \sum_{j=1}^N \ln \mathbf{DIS}_{ij} \right) \right] \end{aligned}$$

$$\begin{aligned} \ln \mathbf{P}_i^{*1-\sigma} &= \frac{1}{2} \left[ \frac{1}{N} \sum_{j=1}^N \ln(\mathbf{GDP}_j / \mathbf{GDP}^T)^* - \ln\left(\frac{1}{N}\right) \right] \\ &+ a_1 \left[ \frac{1}{N} \left( \sum_{j=1}^N \ln \mathbf{DIS}_{ij} \right) - \frac{1}{2} \frac{1}{N^2} \left( \sum_{i=1}^N \sum_{j=1}^N \ln \mathbf{DIS}_{ij} \right) \right] \end{aligned}$$

(40)

$$\begin{aligned} \ln \mathbf{P}_j^{1-\sigma} &= \frac{1}{2} \left[ \frac{1}{N} \sum_{i=1}^N \ln(\mathbf{GDP}_i / \mathbf{GDP}^T) - \ln\left(\frac{1}{N}\right) \right] \\ &+ a_2 \left[ \frac{1}{N} \left( \sum_{i=1}^N \mathbf{BORDER}_{ji} \right) - \frac{1}{2} \frac{1}{N^2} \left( \sum_{i=1}^N \sum_{j=1}^N \mathbf{BORDER}_{ji} \right) \right] \\ &+ a_1 \left[ \frac{1}{N} \left( \sum_{i=1}^N \ln \mathbf{DIS}_{ji} \right) - \frac{1}{2} \frac{1}{N^2} \left( \sum_{i=1}^N \sum_{j=1}^N \ln \mathbf{DIS}_{ji} \right) \right] \end{aligned}$$

$$\begin{aligned} \ln \mathbf{P}_j^{*1-\sigma} &= \frac{1}{2} \left[ \frac{1}{N} \sum_{i=1}^N \ln(\mathbf{GDP}_i / \mathbf{GDP}^T)^* - \ln\left(\frac{1}{N}\right) \right] \\ &+ a_1 \left[ \frac{1}{N} \left( \sum_{i=1}^N \ln \mathbf{DIS}_{ji} \right) - \frac{1}{2} \frac{1}{N^2} \left( \sum_{i=1}^N \sum_{j=1}^N \ln \mathbf{DIS}_{ji} \right) \right] \end{aligned}$$

where  $\mathbf{BORDER}_{ij} = 1$  if regions  $i$  and  $j$  are not in the same nation and 0 otherwise.

Equations (40) are reported to emphasize three points, noting that the last two equations for country  $j$  are symmetric to the first two for country  $i$ . The first two equations for country  $i$  differ in two respects. First,  $\ln \mathbf{P}_i^{1-\sigma}$  differs from  $\ln \mathbf{P}_i^{*1-\sigma}$  because the former includes the “border” component. Second, note that the GDP shares will differ in the two equilibria, because GDPs are endogenous variables. Thus, the multilateral resistance terms are endogenous variables. However, we will ignore the latter differences since – at the suggestion of A-vW (2003, footnote 26, p. 183) – the GDP-share changes are quantitatively trivial and, consequently, the multilateral price terms are determined exclusively by *exogenous* distance and border variables. Our robustness analysis will support this simplification.<sup>22</sup> Finally, as footnote 21 addressed, equations (40) distinguish BV-OLS from fixed effects; the latter *cannot* deliver comparable equations of multilateral resistance terms without constructing the nonlinear system of price equations.

The presence of border barriers tends to increase multilateral resistance levels in countries. Moreover, MR increases tend to be higher for small (GDP) countries relative to large countries. A-vW’s Table 3 illustrated these price level increases. Our Table 2 reports the ratios of the (average) price levels with barriers relative to those without barriers for the U.S. states and Canadian provinces from A-vW and from our BV-OLS estimates. Using BV-OLS, the increase in price levels is relatively higher for relatively smaller Canadian provinces and the magnitudes of the increases are comparable to those in A-vW.<sup>23</sup>

We are now ready to address the impact of border barriers on bilateral trade flows between Canadian provinces, between U.S. states, and between Canadian provinces with U.S. states. Substituting equations (40) for the respective terms in equation (39) yields:

$$\begin{aligned} \mathbf{BB}_{ij} &= \ln \mathbf{x}_{ij} - \ln \mathbf{x}_{ij}^* \\ &= a_2 - a_2 \left\{ \left[ \frac{1}{N} \left( \sum_{j=1}^N \mathbf{BORDER}_{ij} \right) + \frac{1}{N} \left( \sum_{i=1}^N \mathbf{BORDER}_{ij} \right) - \frac{1}{N^2} \left( \sum_{i=1}^N \sum_{j=1}^N \mathbf{BORDER}_{ij} \right) \right] \right\} \end{aligned} \quad (41)$$

---

<sup>22</sup>As discussed in A-vW’s Appendix B, the  $\theta$ s change between states BB and NB, although these changes are negligible. Moreover, the effects of these changes do not matter materially for equation (39).

Since  $\sum_{j=1}^N \ln \theta_j = \sum_{i=1}^N \ln \theta_i$  and  $\sum_{j=1}^N \ln \theta_j^* = \sum_{i=1}^N \ln \theta_i^*$ , then  $\frac{1}{N} \sum_{j=1}^N \ln \theta_j - \frac{1}{N} \sum_{j=1}^N \ln \theta_j^*$  will be trivially different from zero. For instance, consider a two-region world. Suppose  $\theta_1 = \theta_2 = 0.50$  and suppose  $\theta_1^* = 0.52$  and  $\theta_2^* = 0.48$ . Then  $\frac{1}{N} \left( \sum_{j=1,2} \ln \theta_j - \sum_{j=1,2} \ln \theta_j^* \right)$  equals 0.0008 for  $N=2$ .

<sup>23</sup>The estimate of the correlation coefficient between price levels estimated using A-vW and those using BV-OLS is 0.92.

where the distance components of the multilateral price terms cancel out and, as discussed above and in A-vW, the income-share differences are trivially small and consequently ignored. Thus, estimates of the comparative static border barriers do not *require* estimating the  $P_i^{1-\sigma}$ ,  $P_i^{*1-\sigma}$ ,  $P_j^{1-\sigma}$ , and  $P_j^{*1-\sigma}$  terms using a custom nonlinear program.

Table 3 – similar to A-vW’s Table 4 – reports the ratios of average bilateral trade with border barriers (BB) to bilateral trade without border barriers (NB). Like A-vW, we decompose the ratio into that portion due to a change in bilateral resistance and that portion due to a change in multilateral resistance. The first two parts of Table 3 reproduce the relevant estimates from A-vW’s Table 4 for both the two-country and multi-country cases. The third part reports our comparable estimates using BV-OLS.

The notable finding in Table 3 is that the BV-OLS estimates of the impact of border barriers on bilateral trade are virtually identical to A-vW’s multi-country NLLS estimates. The economic interpretation of the BV-OLS estimates is the same as in A-vW and need not be reproduced. However, we emphasize two important results. First, cross-border U.S.-Canada trade is 0.56-0.57 of its level without the border, implying a reduction of 43-44 percent, considerably smaller than that in McCallum (1995). Second, as suggested in McCallum and A-vW, bilateral resistance reduces bilateral international trade by 78-80 percent. However, the increase in trade due to the increase in multilateral resistance offsets this dramatically, with the MR increase causing more state-province trade by a factor of 2.6-2.7.

Finally, Table 4 – akin to A-vW’s Table 5 – reports the results of estimating the impact of national borders on the ratio of (average) *intranational* trade to (average) international trade. Not surprisingly, the BV-OLS estimates are very close in magnitude to the values implied using the more complex A-vW NLLS procedure.

### B. Intuition

We now explain intuitively why BV-OLS works here. To do so, we draw upon the simple insightful conceptual example in A-vW (2003, p. 177):

Consider the following example . . . . A small economy with two regions and a large economy with 100 regions engage in international trade. All regions have the same GDP.

A modification of this example to the U.S.-Canadian border-puzzle setting – 10 Canadian provinces and 30 U.S. states – along with a consistent estimate of the cross-border dummy variable coefficient,  $\alpha(1-\sigma)$ , is sufficient to generate the country-specific comparative-static border effects.

### 1. A-vW's Implication 1

First, we know from equation (41) that the log of the ratio of average trade from a region in Canada (i) to a region in the United States (j) with and without a border, or  $\ln(\mathbf{x}_{ij}/\mathbf{x}_{ij}^*)$ , can be written as:

$$\frac{d\ln\mathbf{x}_{ij}}{d\mathbf{BORDER}_{ij}} = \alpha(1-\sigma) \left[ 1 - \frac{1}{N} \left( \sum_{j=1}^N \mathbf{BORDER}_{ij} \right) - \frac{1}{N} \left( \sum_{i=1}^N \mathbf{BORDER}_{ij} \right) + \frac{1}{N^2} \left( \sum_{i=1}^N \sum_{j=1}^N \mathbf{BORDER}_{ij} \right) \right] \quad (42)$$

For convenience, we define measures of “border proportions” for Canada and the United States:

$$\delta_{CA} = \frac{1}{N} \left( \sum_{j=1}^N \mathbf{BORDER}_{ij} \right) = \frac{30}{40} \quad \delta_{US} = \frac{1}{N} \left( \sum_{i=1}^N \mathbf{BORDER}_{ij} \right) = \frac{10}{40}$$

where N, the number of regions in this world, is 40. It follows that:

$$\frac{1}{N^2} \left( \sum_{i=1}^N \sum_{j=1}^N \mathbf{BORDER}_{ij} \right) = 2\delta_{CA}\delta_{US}$$

Hence:

$$\frac{d\ln\mathbf{x}_{ij}}{d\mathbf{BORDER}_{ij}} = \alpha(1-\sigma) \left[ 1 - \delta_{CA} - \delta_{US} + 2\delta_{CA}\delta_{US} \right]. \quad (43)$$

Second, note that – in this context –  $\delta_{CA}$  and  $\delta_{US}$  are each negatively related to their respective country's share of the two countries' GDP. Specifically,

$$\delta_{CA} = 1 - \theta_{CA} \quad \delta_{US} = 1 - \theta_{US}$$

where – with each region having identical GDP (as in A-vW) –  $\theta_{CA}$  (= 10/40) is Canada's share of both countries' GDPs and  $\theta_{US}$  (= 30/40) is the U.S. share of their GDPs. Substituting  $1-\theta_{CA}$  ( $1-\theta_{US}$ ) for  $\delta_{CA}$  ( $\delta_{US}$ ) in eq. (43) yields:

$$\begin{aligned}
\frac{d\ln x_{ij}}{dBORDER_{ij}} &= \alpha(1-\sigma) \left[ 1 - (1-\theta_{CA}) - (1-\theta_{US}) + 2(1-\theta_{CA})(1-\theta_{US}) \right] \\
&= -(\sigma-1) \left[ \theta_{CA} + \theta_{US} - \sum_{k=CA,US} \theta_k^2 \right] \alpha
\end{aligned} \tag{44}$$

since  $2\theta_{CA}\theta_{US} = 1 - \theta_{CA}^2 - \theta_{US}^2$  when  $\theta_{CA}$  ( $\theta_{US}$ ) is a fraction. Recall that  $\alpha$  represents the conversion of the border effect into the log of the gross trade-cost factor.

Note that eq. (44) above and eq. (15) in A-vW are *identical*. Equations (43) and (44) – like AvW’s eq. (15) – support A-vW’s “Implication 1.” The larger are the two countries’ GDPs (as a share of all the N regions in the world), the larger the effect of a national border on their size-adjusted international trade. See A-vW for further intuition.

Consequently, equation (43) provides a ready estimate of the log of the ratio of average trade from a region in Canada to a region in the United States with a border to that without a border. Equation (43) can be rewritten as:

$$\frac{d\ln x_{ij}}{dBORDER_{ij}} = \alpha(1-\sigma) \left[ 1 - (\delta_{CA} - \delta_{CA}\delta_{US}) - (\delta_{US} - \delta_{CA}\delta_{US}) \right] \tag{45}$$

The direct bilateral effect is  $\alpha(1-\sigma)(1) < 0$ , which is estimated using A-vW, fixed effects, or BV-OLS. A-vW suggests -1.65; BV-OLS (fixed effects) suggests -1.53 (-1.54). The second RHS term –  $-\alpha(1-\sigma)(\delta_{CA} - \delta_{CA}\delta_{US}) > 0$  – represents the offsetting effect of the change in Canada’s theoretically-motivated multilateral resistance term. The effect of the change in U.S. multilateral resistance is represented by the third RHS term  $-\alpha(1-\sigma)(\delta_{US} - \delta_{CA}\delta_{US}) > 0$ . Simply substituting  $\delta_{CA} = 30/40$ ,  $\delta_{US} = 10/40$ , and an estimate of  $-\alpha(1-\sigma)$ , say -1.53, into (45) yields an estimate of the log ratio of an average Canadian region’s trade to a U.S. region with and without a border, or  $-(1.53)(0.375) = -0.5738$ . This implies a  $Ratio_{BB/NB} = e^{-0.5775} = 0.56$  – which is nearly *identical* to the estimate of  $Ratio_{BB/NB}$  in Table 3 using either BV-OLS or the A-vW Multi-country NLLS estimation procedures.<sup>24</sup>

---

<sup>24</sup>Using the estimate of  $\alpha(1-\sigma) = -1.65$  from A-vW’s two-country model,  $(-1.65)(0.375) = -0.619$ , implying a  $Ratio_{BB/NB} = e^{-0.619} = 0.54$ , slightly larger than the A-vW two-country  $Ratio_{BB/NB} = 0.41$ .

### 2. A-vW's Implication 2

It will not be surprising then to learn that our model also supports A-vW's Implication 2: a border increases size-adjusted trade within small countries more than within large countries. In our model for Canada:

$$\frac{d\ln \mathbf{x}_{ii}}{d\mathbf{BORDER}_{ij}} = \alpha(1 - \sigma) \left[ 0 - \delta_{CA} - \delta_{CA} + 2\delta_{CA} \delta_{US} \right] \quad (46)$$

Substituting  $\theta_{CA} = 1 - \delta_{CA}$  and  $\theta_{US} = 1 - \delta_{US}$  into equation (46) yields:

$$\frac{d\ln \mathbf{x}_{ii}}{d\mathbf{BORDER}_{ij}} = (\sigma - 1) \left[ 1 - 2\theta_{CA} + \sum_{k=CA,US} \theta_k^2 \right] \alpha \quad (47)$$

Equation (47) is identical to equation (16) in A-vW. Consequently, Canada's size-adjusted intranational trade should increase more than U.S. intranational trade with a border introduced. Substituting  $\delta_{CA} = 30/40$ ,  $\delta_{US} = 10/40$ , and the estimate of  $-\alpha(1-\sigma)$ , -1.53, into (47) yields a value of 1.72. This implies intranational Canadian trade increase by a factor of  $e^{1.72} = 5.59$ , similar to our BV-OLS estimate and slightly less than the estimate in A-vW's multi-country model (see Table 3). The analogous estimate for the United States is 1.21, similar to our BV-OLS estimate and slightly less than A-vW's multi-country model estimate (see Table 3).

### 3. A-vW's Implication 3

A-vW's Implication 3 follows from Implications 1 and 2 here as well:

$$\begin{aligned} \frac{d\ln(\mathbf{x}_{ii} / \mathbf{x}_{ij})}{d\mathbf{BORDER}_{ij}} &= (\sigma - 1) \left[ 1 - 2\theta_{CA} + \sum_{k=CA,US} \theta_k^2 \right] \alpha & (48) \\ &- [ -(\sigma - 1) ] \left[ \theta_{CA} + \theta_{US} - \sum_{k=CA,US} \theta_k^2 \right] \alpha \\ &= (\sigma - 1) [ 1 - \theta_{CA} + \theta_{US} ] \alpha \end{aligned}$$

Equation (48) is identical to equation (17) in A-vW. Consequently, a national border increases intranational relative to international trade more the smaller is Canada and the larger is the United States, as in A-vW's Implication 3. Substituting  $\delta_{CA} = 30/40$ ,  $\delta_{US} = 10/40$ , and the estimate of  $-\alpha(1-\sigma)$ , -1.53, into equation (48) yields a value of 2.295. This implies that intranational relative to international Canadian trade increases by a factor of 9.92 due to the U.S.-Canadian border, in line with estimates in Table 4 (footnote). Finally, intranational relative to international U.S. trade increases by a factor of 2.15, similar to that found in Table 4 (footnote).

### C. Fixed-Point Iteration

This section has demonstrated so far that BV-OLS provides an excellent *first-order* approximation to estimating average effects of EIAs and certain comparative-static effects, such as country-specific border effects. However, because BV-OLS is a linear approximation of a nonlinear system, it cannot provide very precise estimates of the numerous *region-specific* or *region-pair-specific* comparative statics that may be desired for policy purposes. That is, region-specific multilateral resistance terms – in the context here, state- or province-specific MR terms – generated by BV-OLS are likely to provide poor estimates of the region-specific MR terms generated using custom NLLS estimation of the full general-equilibrium model.

Is there an easy way to estimate precisely A-vW's region-specific MR terms *without* nonlinear estimation? We can show that the region-specific price terms can be obtained readily using a simple (iterative) matrix manipulation technique that is computationally much less resource-intensive than the nonlinear estimation technique used by A-vW, as it does not require computation of the Jacobian of the system of equations, nor does it even require that the inverse of the Jacobian exists. The process is based upon fixed-point iteration.

We summarize the process briefly, referring the reader to Appendix A for technical details. First, calculate initial estimates of every  $P_i^{1-\sigma}$  ( $P_i^{*1-\sigma}$ ) using BV-OLS, denoted  $P_i^{1-\sigma_0}$  ( $P_i^{*1-\sigma_0}$ ), for every region ( $i = 1, \dots, N$ ). Denote the  $N \times 1$  vector of these MR terms  $V_0$  ( $V_0^*$ ) and the  $N \times 1$  vector of the inverses of each of these MR terms  $V_0^-$  ( $V_0^{-*}$ ). Second, define an  $N \times N$  matrix of GDP-share-weighted trade costs,  $B$ , where each element,  $b_{ij}$ , equals  $\theta_{ij}^{1-\sigma}$ . Third, compute  $V_{k+1}$  according to:

$$V_{k+1} = zBV_k^- + (1-z)V_k \quad (49)$$

starting at  $k = 0$  until successive approximations are less than a predetermined value of  $\varepsilon$  (say,  $1 \times 10^{-9}$ ),

where  $\varepsilon = \max|V_{k+1} - V_k|$  and  $z$  is a dampening factor with  $z \in (0,1)$ , and analogously for  $V_k^*$ .

Given the initial estimates of  $P_i^{1-\sigma}$  ( $P_i^{*1-\sigma}$ ) using BV-OLS ( $i = 1, \dots, N$ ), this fixed-point iteration process will converge to the set of multilateral price terms identical to those generated using A-vW's NLLS program. We have run this set of matrix calculations and the correlation coefficient between our MR terms (using fixed-point iteration) and A-vW's MR terms (using NLLS) is 1.0 (reported to seven decimal places). Consequently, any *region-pair-specific* border effects – such as that between Alabama Quebec – are identical.

## 6. BV-OLS Works Well: Evaluating Robustness using a Monte Carlo Analysis

The previous two sections have addressed the second set of questions posed at the end of section 3A: Does BV-OLS estimation work empirically as an approximation to A-vW (allowing for measurement and specification error), and why? While NLLS of the A-vW system of equations, BV-OLS, and fixed-effects specifications should all generate similar estimates of  $-\rho(\sigma-1)$  and  $-\alpha(\sigma-1)$ , comparisons of Table 1's empirical results for specifications (2), (4), and (5) yield significantly different results. Notably, BV-OLS (spec. 4) and fixed effects (spec. 5) yield similar results, but both differ sharply from estimation using NLLS (spec. 2). Why? As discussed in section 4, A-vW's NLLS procedure is highly sensitive to the measurement of internal distances for the multilateral resistance terms and potential specification error. Is there a way to compare the estimation results of A-vW and BV-OLS *excluding* the measurement error introduced by internal distances' mis-measurement and potential specification error?

In this section, we employ a Monte Carlo approach to show that the BV-OLS method yields estimates of average- and country-specific border effects that are virtually identical to those using A-vW's NLLS method when we know the “true” model, but are much simpler to compute. To do this, we construct the “true” bilateral international trade flows among 41 regions using the theoretical model of A-vW described in section 2. We assume the world is described precisely by equations (11) and (12.1)-(12.41), assuming various arbitrary values for  $\alpha$ ,  $\rho$ , and  $\sigma$  under alternative scenarios. Using data on GDPs and bilateral distances and dummy variables for borders, we can compute the *true* bilateral trade flows *and true* multilateral resistance terms associated with these economic characteristics for given values of parameters  $\alpha$ ,  $\rho$ , and  $\sigma$ .

We then assume that there exists a log-normally distributed error term for each trade flow equation. We make 5,000 draws for each trade equation and run various regression specifications 5,000

times.<sup>25</sup> We will consider first two different sets of given parameter values and five specifications. We use *GAUSS* in all estimates.

Finally, to show that this approach works in the more traditional context of world trade flows, we employ the same Monte Carlo approach in this alternative context in sub-section C.

#### A. Specifications

We consider five specifications. Specification (1) is the basic gravity model ignoring multilateral resistance terms, as used by McCallum. The specification is analogous to equation (11) excluding the MR terms. In the context of the theory, we should get biased estimates of the true parameters since we intentionally omit the true multilateral price terms or fixed effects.

Specification (2) is the basic gravity model augmented with “atheoretical remoteness” terms ( $\mathbf{REMOTE}_i$  and  $\mathbf{REMOTE}_j$ ), as in McCallum (1995), Helliwell (1996, 1997, 1998), and Wei (1996). Equation (11) would include  $\mathbf{REMOTE}_i$  and  $\mathbf{REMOTE}_j$ , instead of  $P_i$  and  $P_j$ , where  $\mathbf{REMOTE}_i = \ln \Sigma_j^N (\mathbf{DIS}_{ij} / \mathbf{GDP}_j)$  and analogously for  $\mathbf{REMOTE}_j$ . In the context of the theory, we should get biased estimates of the true parameters since we are using atheoretical measures of remoteness. This specification also ignores other multilateral trade costs.

For Specification (3), we take the system of equations described in equations (12.1)-(12.41) to generate the “true” multilateral resistance terms associated with given values of  $-\rho(\sigma-1)$  and  $-\alpha(\sigma-1)$ . We then estimate the regression (11) using the true values of the multilateral resistance terms. In the presence of the true MR terms, we expect the coefficient estimates to be virtually identical to the *true* parameters.

As discussed earlier, country-specific fixed effects should also generate unbiased estimates of the coefficients. For robustness, we also run Specification (4), which includes region fixed effects instead.

Specification (5) is BV-OLS, or equation (36). If our hypothesis is correct, then the parameter estimates should be virtually identical to those estimated using Specifications 3 and 4.

#### B. Monte Carlo Simulations

Initially, we run these five specifications for two different scenarios of values for  $a_1 = -\rho(\sigma-1)$  and  $a_2 = -\alpha(\sigma-1)$ . In both cases, we report three statistics. First, we report the average coefficient estimates for  $a_1$  and  $a_2$  from the 5,000 regressions for each specification. Second, we report the standard

---

<sup>25</sup>The error terms’ distribution is such that the  $R^2$  (and standard error of the estimate) from a regression of trade on GDP, distance, and borders using a standard gravity equation is similar to that typically found (an  $R^2$  of 0.7 to 0.8).

deviation of these 5,000 estimates. In the third column, we report the fraction of times (from the 5,000 regressions) that the coefficient estimate for a variable was within two standard errors of the true coefficient estimate.<sup>26</sup> All estimation was done using *GAUSS*.

1. Assume  $-\rho(\sigma-1) = -0.79$  and  $-\alpha(\sigma-1) = -1.65$

For Scenario 1, we use the actual coefficient estimates found in A-vW using their two-country model. Table 5 reports the estimated values for the five specifications under this scenario. There are two major results worth noting. First, the first two specifications provide biased estimates of the border and distance coefficient estimates, as expected. Second, both fixed effects and BV-OLS provide estimates very close to those using Specification 3, as expected. While the average BV-OLS coefficient estimates depart slightly from the average A-vW estimates, note that 98 percent of the border and distance (coefficient) estimates are within two standard errors of the true value.

2. Assume  $-\rho(\sigma-1) = -1.25$  and  $-\alpha(\sigma-1) = -1.54$

Now we choose values for  $-\rho(\sigma-1)$  and  $-\alpha(\sigma-1)$  that are identical to those estimated using fixed effects in Table 1. Table 6 provides the same set of information as in Table 5, but for this alternative set of true values. The results are robust to this alternative set of parameters. The BV-OLS coefficient estimates are within two standard errors of the true values 99 percent of the time.

The “average” coefficient estimates using BV-OLS are very close in magnitude to those estimated using either the true MR terms or using fixed effects. In both cases, the coefficient estimates for **BORDER** (**lnDIS**) are within 1 (2) percent of the true value. While not as accurate as fixed effects in terms of the *average* coefficient estimates, we note that the fraction of times that the BV-OLS estimates are within two standard errors of the true value is 99 percent, which exceeds Specification 3 as well as Specification 4.

3. Vary  $-\rho(\sigma-1)$  and  $-\alpha(\sigma-1)$  each between  $-0.25$  and  $-2.00$

Given the success of these results, we decided to perform these simulations for a wide range of arbitrary values of the parameters. We considered a range for each variable’s “true” coefficient from  $-0.25$  to  $-2.00$ . Because of the large number of simulations, we used 1,000 runs per parameter pair. We

---

<sup>26</sup>Note that the standard deviation refers to the square root of the variance of all the coefficient estimates for a specification. We also calculated the standard errors of each coefficient estimate. The last column in each table refers to the fraction of the 5,000 regressions that the estimated coefficient is within two standard errors of the true value.

basically found the same findings. For brevity, these are not reported individually. However, we did chart the estimated bias of BV-OLS border and distance variables' coefficient estimates vs. the "true" coefficient estimates.

BV-OLS yields virtually identical border and distance coefficient estimates to the true values. Figure 1a illustrates for the entire range of true Border and Distance coefficients the bias on the Border coefficient estimate from using BV-OLS. The BV-OLS bias for Border is smallest when Border's (true) coefficient is -2.00 and Distance's (true) coefficient is -0.25. By contrast, the BV-OLS bias for Border is largest (0.04) when Border's coefficient is -0.25 and Distance's coefficient is -2.00.

However, Figure 1b illustrates the fraction of times that the BV-OLS coefficient estimate for Border falls within two standard errors of the true Border coefficient. Two points are worth noting. First, when the absolute size of the BV-OLS bias for Border's coefficient estimate is largest – when Border's coefficient is -0.25 and Distance's coefficient is -2.00 – the BV-OLS Border coefficient estimate is within two standard errors of the true value 99.5 percent of the time. Second, regardless of the true values of the Border and Distance coefficients, the BV-OLS Border coefficient estimate is within two standard errors of the true value no less than 93 percent of the time.

Figures 2a and 2b report the analogous findings for the BV-OLS Distance coefficient estimate's bias. Figure 2a indicates that the largest Distance coefficient estimate bias (0.05) occurs when the distance elasticity is -2.00. However, Figure 2b reports that the BV-OLS Distance coefficient estimate is within two standard errors of the true coefficient about 95 percent of the time. Similar to Border, the BV-OLS Distance coefficient estimate is within two standard errors of the true value no less than 93 percent of the time.

### *C. Implications for Gravity Equations for World Trade Flows*

As noted earlier, the gravity equation has been used over the past four decades to analyze economic and political determinants of a wide range of aggregate "flows." However, the most common usage of the gravity equation has been for explaining *world* (intra- and inter-continental) bilateral trade flows. Surely, the issues raised in A-vW (2003) and in this paper have potential relevance to the estimation of the effects of free trade agreements and of tariff rates on world trade flows. In the spirit of addressing the "generality" of our technique to other contexts, we offer another sensitivity analysis of our technique.

In this section, we construct an artificial set of aggregate bilateral world trade flows among 88

countries for which data on the exogenous RHS variables discussed above were readily available.<sup>27</sup> Three exogenous RHS variables that typically explain world trade flows are countries' GDPs, their bilateral distances, and a dummy representing the presence (0) or absence (1) of a common land border ("NoAdjacency"). We then estimate the relationship among bilateral trade flows, national incomes, bilateral distances and NoAdjacency among 88 countries using BV-OLS. We simply redo Section 6's Monte Carlo simulations.<sup>28</sup>

We start with the system of equations (11) and (12), modified to 88 regions. Initially, we assigned two sets of possible parameters for  $-\alpha(\sigma-1)$  and  $-\rho(\sigma-1)$ , the same two sets of values used for Tables 5 and 6 (the original 2-country A-vW estimates and the fixed-effects estimates). We then calculated the "true" MR terms and "true" trade flows using equations (11) and (12). We then assume there exists a log-normally distributed error term. We make 1,000 draws for the equation and run various specifications 1,000 times.

For the world data set, the countries are chosen according to data availability and include the largest of the world's economies. GDPs in thousands of U.S. dollars are from the World Bank's *World Development Indicators*. Bilateral distances were calculated using the standard formula for geodesic, or "great circle," distances (<http://mathworld.wolfram.com/GreatCircle.html>). NoAdjacency is a dummy variable defined as 0 (1) if the two countries actually share (do not share) a common land border. In the typical gravity equation for world trade flows, adjacency is expected to augment trade; hence, NoAdjacency (like Border in the previous section) has an expected negative relationship with trade.

The notable finding is that the estimation biases for world trade flows are *very small*, even relative to those found for BV-OLS for the intra-continental (Canadian-U.S.) trade flow specifications. For example, consider the results for  $-\alpha(\sigma-1) = -1.65$  and  $-\rho(\sigma-1) = -0.79$ . For U.S.-Canadian trade, the average Border estimation bias is 0.42 percent and the fraction of times the estimate is within two standard errors of the true value is 0.985. The average Distance estimation bias is 1.52 percent and the

---

<sup>27</sup>The 88 countries are Argentina, Australia, Austria, Bangladesh, Belgium, Bolivia, Brazil, Bulgaria, Canada, Chile, China, Colombia, Costa Rica, Cote d'Ivoire, Cyprus, Denmark, Dominican Republic, Ecuador, Egypt, El Salvador, Finland, France, The Gambia, Germany, Ghana, Greece, Guatemala, Guinea-Bissau, Guyana, Haiti, Honduras, Hong Kong, Hungary, India, Indonesia, Iran, Ireland, Israel, Italy, Jamaica, Japan, Kenya, South Korea, Madagascar, Malawi, Malaysia, Mali, Mauritania, Mauritius, Mexico, Morocco, Mozambique, Netherlands, New Zealand, Nicaragua, Niger, Nigeria, Norway, Pakistan, Panama, Paraguay, Peru, Philippines, Poland, Portugal, Romania, Saudi Arabia, Senegal, Sierra Leone, Singapore, Spain, Sri Lanka, Sudan, Sweden, Switzerland, Syria, Thailand, Trinidad and Tobago, Tunisia, Turkey, Uganda, United Kingdom, United States, Uruguay, Venezuela, Zaire, Zambia, and Zimbabwe.

<sup>28</sup>Naturally, we could also introduce in this exercise an array of other typical bilateral dummies, such as common language, common EIA, etc. However, this would have no bearing on the generality of our results.

fraction of times the estimate is within two standard errors of the true value is 0.978. However, for world trade, the average Border estimation bias is 0.18 percent and the fraction of times the estimate is within two standard errors of the true value is 0.992. The average Distance estimation bias is 0.13 percent and the fraction of times the estimate is within two standard errors of the true value is 0.996. The results for  $\alpha(\sigma-1) = -1.54$  and  $-\rho(\sigma-1) = -1.25$  are similar. These results support our conjecture that BV-OLS works well in other contexts also.

In a robustness analysis, we have found that the small estimation bias is systematic. Figure 3a illustrates the estimation bias for all parameter values between -0.25 and -2.00 of the NoAdjacency variable's coefficients for the 88-country specification. As for Figure 1a, the estimation bias is small. In fact, 79.4 percent of the estimation biases are smaller for world trade flows compared with intra-continental trade flows, although the two "border" variables have different economic interpretations. Figure 3b confirms that the fraction of estimates within two standard errors of the true values is very high for world trade flows.

Figure 4a illustrates the estimation bias for all parameter values between -0.25 and -2.00 of the distance variables' coefficients for the 88-country specification. The distance variable is measured in the same manner for both data sets. Figure 4a illustrates that for *all* parameter values for the distance variables' coefficients the estimation bias for world trade flows is less than that for regional trade flows. Figure 4b shows that the fraction of estimates within two standard errors of the true values is also consistently high for world trade flows.<sup>29</sup>

These findings provide quantitative support to our hypothesis that BV-OLS is not only a good approximation to NLLS, but that it works just as effectively in the context in which it is most often used – the analysis of *global* trade flows.

#### D. Summary

This section has addressed the third question raised at the end of section 3A: Using Monte Carlo analysis to eliminate measurement and specification errors, does BV-OLS work well? The Monte Carlo analysis indicates that BV-OLS is a good (log) linear approximation to the underlying nonlinear model. Coefficient estimates for the Distance and Border variables are within 0.05 of the true values. The

---

<sup>29</sup>The systematically lower estimation bias for the distance coefficients for world relative to regional trade flows is an issue of current research by the authors, the subject of which exceeds considerably the scope of this already lengthy paper. Because the two border variables have different economic interpretations, we also conducted the Monte Carlo analyses for the two data sets in the absence of a border variable in both "true" models. The results just discussed for Distance are very similar in that setting.

fraction of times that the BV-OLS coefficient estimates are within two standard errors of the true values is at least 93 percent, and ranges up occasionally to 99.5 percent. We find that in either context – intra-continental Canadian-U.S. trade or intra- and inter-continental international trade – estimation using A-vW's custom NLLS, fixed effects, or BV-OLS yield similar results, which are much more accurate estimates of gravity equation parameters than either the traditional gravity equation or the traditional specification including atheoretical “remoteness” terms.

The quantitative findings that these estimates from a first-order log-linear approximation to an underlying nonlinear surface are quite good suggests that higher-order terms are not very important. We now address the fourth – and final – question posed at the end of section 3A: *Why* does BV-OLS work so well? Using a Monte Carlo analysis, we provide some quantitative evidence suggesting that higher-order terms are empirically *irrelevant*.

### 7. *Why BV-OLS Works Well: The Empirical Irrelevance of Higher-Order Terms*

As well established by now, BV-OLS uses a *first-order* Taylor-series expansion; higher-order terms were intentionally omitted to derive an estimable OLS equation. However, the degree of estimation bias is clearly influenced by the empirical relevance or irrelevance of higher-order terms. Since an  $n^{\text{th}}$ -order Taylor-series expansion of a function is the sum of the first-order term and  $(n-1)$  higher-order terms, there is a ready analogue to the issue of measurement error (and endogeneity bias) in econometrics. In econometric terms, we can think of the “true” multilateral price resistance (MR) term as the sum of the observed MR term (the first-order linear approximation, denoted  $MR^*$ ) and a measurement error  $v$  (the  $n-1$  higher-order terms). We know that  $v$  is correlated with the true MR term, by construction. However, we do not know if  $v$  is correlated with the first-order term,  $MR^*$ . This is the source of concern because a non-zero correlation of  $v$  and  $MR^*$  generates estimation bias for BV-OLS.

In the first sub-section, we discuss a second-order expansion of the system of price equations, centered around a symmetric equilibrium. Although one cannot solve for an analytical solution (as in the first-order case), the expansion suggests that the second-order terms include variances and covariances of the underlying variables. Clearly, heterogeneity of trade costs and GDP shares, and their interactions, influence the degree of estimation bias of the MR terms. Yet, these variance and covariance terms are also potentially correlated with the first-order terms, creating a possible estimation (endogeneity) bias of the Distance and Border coefficient estimates.<sup>30</sup>

---

<sup>30</sup>The degree of estimation bias is, of course, also influenced by the degree of curvature of the underlying model (i.e., the values of  $a_1$  and  $a_2$ ). In the previous section, we demonstrated quantitatively the sensitivity of the estimation bias to a wide range of plausible parameter values, -0.25 to -2.00. We address this as well later in this

In the second sub-section, we turn to an econometric analysis to demonstrate the empirical irrelevance of higher-order terms for estimating the coefficient estimates. We examine the deviations of the estimated MR terms from their “true” values, which reflect the higher-order terms of a higher-order expansion. Since the higher-order terms would be embedded in the error terms of a BV-OLS regression, estimation bias of the coefficients would be attributable to these terms and such terms would be correlated with the RHS variables in the BV-OLS specification. We demonstrate empirically that the price deviations – representing higher-order terms – are uncorrelated with the RHS variables. BV-OLS works well because higher-order terms are empirically *irrelevant!*

#### A. Sources of Estimation Bias from a First-Order Approximation

BV-OLS uses a first-order log-linear expansion centered around a symmetric world (akin to centering around the “mean” values of the underlying variables). BV-OLS should approximate the coefficients of underlying nonlinear system better the lower the correlation of higher-order terms with BV-OLS’ RHS terms.

To illustrate this, we consider a formal *second-order* log-linear Taylor-series expansion of equation (8) [or (14)]. For brevity, we present in Appendix B the first stage of the expansion. Appendix B demonstrates three results. First, variances of the underlying GDP-share and trade-cost variables are important in explaining the estimation bias (second, third and fourth RHS terms in Appendix B equation (B1)). Second, *covariances* among the underlying variables are potentially important for influencing the degree of curvature of the underlying multilateral price terms (fifth, sixth, and seventh RHS terms in Appendix B equation (B1)). Third, the relationships among these factors are highly nonlinear and no analytical solution exists (as one did for the first-order expansion earlier). Third- and higher-order terms would make this relationship even more complex.

Econometrically, we know that BV-OLS will yield biased estimates of  $a_1$  and  $a_2$  if there are any omitted variables correlated with the MR variables that are being captured by the BV-OLS error terms. Appendix B equation (B1) suggests that there are potential higher-order terms, such as the covariances in equation (B1), that may be correlated with the BV-OLS RHS terms. We argue that BV-OLS has little estimation bias because second- and higher-order terms are uncorrelated with the first-order terms on the RHS of BV-OLS.

#### B. Estimation of Higher-Order Terms

---

section.

Since, as Appendix B shows, we cannot solve analytically for a higher-order expansion of  $\ln P^{\sigma-1}$ , we must estimate the influence of higher-order terms indirectly. The BV-OLS approach yields an estimate of  $\text{MR}_{ij} = \ln P_i^{\sigma-1} + \ln P_j^{\sigma-1}$  using first-order terms – henceforth,  $\text{MR}_{ij}^e$ . These are obtained using equation (36), along with estimated values of  $a_1 = -\rho(\sigma-1)$  and  $a_2 = -\alpha(\sigma-1)$ . If, in the limit, MR can be represented by an  $n^{\text{th}}$ -order Taylor-series expansion, then deviations of  $\text{MR}_{ij}^e$  from  $\text{MR}_{ij}$  – henceforth,  $v_{ij}$  – represent the higher-order terms that are known to be correlated with  $\text{MR}_{ij}$  (which will not generate estimation bias) and are potentially correlated with  $\text{MR}_{ij}^e$  (which would generate estimation bias).

We use the A-vW NLLS procedure in Specification 3 in Section 6 to generate the “true” MR terms. Of course, even a NLLS computer program uses an “approximation” method to generate the “true” MR terms. Moreover, *GAUSS* uses a first-order iterative Taylor-series expansion around the parameters  $(a_0, a_1, a_2)$  – a Quasi-Newton method – to solve the system. However, the procedure used by *GAUSS* to generate the “true”  $\text{MR}_{ij}$  terms is fundamentally different from that used to generate the  $\text{MR}_{ij}^e$  terms using BV-OLS.<sup>31</sup>

We then calculate  $v_{ij} = \text{MR}_{ij} - \text{MR}_{ij}^e$ , which represent the higher-order terms. BV-OLS will yield biased estimates if  $v_{ij}$  is correlated with  $\text{MR}_{ij}^e$ . We ran 5000 regressions of  $v_{ij}$  on **MWRDIS<sub>ij</sub>**, **MWRBORDER<sub>ij</sub>**, and a constant on each of two sets of parameter values, the same two sets used in Section 6.B.1 and 6.B.2. *In no regression was the coefficient estimate for MWRDIS<sub>ij</sub> or for MWRBORDER<sub>ij</sub> economically or statistically significant.* When the Distance (Border) elasticity was -0.79 (-1.65), the average coefficient estimate for **MWRDIS<sub>ij</sub>** was -0.012 with an average standard error of 0.019 and the average coefficient estimate for **MWRBORDER<sub>ij</sub>** was 0.008 with an average standard error of 0.026. When the Distance (Border) elasticity was -1.25 (-1.54), the average coefficient estimate for **MWRDIS<sub>ij</sub>** was -0.027 with an average standard error of 0.036 and the average coefficient estimate for **MWRBORDER<sub>ij</sub>** was 0.011 with an average standard error of 0.047.

We conclude that the first-order log-linear Taylor-series approximation of BV-OLS works well

---

<sup>31</sup>The estimation procedure for NLLS in *GAUSS* actually uses a first-order Taylor-series expansion. However, the procedure is fundamentally different from BV-OLS since the *GAUSS* procedure takes Taylor expansions around *parameters*  $(a_0, a_1, a_2)$  of the system of equations. In the optimization procedure in *GAUSS*, using the Quasi-Newton method, first let  $\beta$  denote the vector of three parameters  $a_0, a_1,$  and  $a_2$  in those 42 equations [(11) and (12.1)-(12.41)]. The Quasi-Newton solution method forms a function,  $f(\beta)$ , which is the sum of the squared errors ( $\epsilon_{ij}$ ) of equation (11) subject to the 41 nonlinear price equation constraints (12.1)-(12.41). Second, the method takes a first-order Taylor-series expansion centered at some arbitrarily-selected initial values of the parameter vector,  $\beta_0$ . The function is then minimized at  $\beta_1$ ; formally, the method chooses  $\beta_1$  such that  $f'(\beta) = f'(\beta_0) - f''(\beta_0)(\beta_1 - \beta_0) = 0$ , or  $\beta_1 = \beta_0 - [f''(\beta_0)]/[f'(\beta_0)]$ . Next, repeat the process substituting  $\beta_1$  for  $\beta_0$ ,  $\beta_2$  for  $\beta_1$ , and so on until  $\beta_j - \beta_{j-1}$  is less than some pre-specified tolerance value (0.000001); the method eventually iterates to a solution for the three parameters in  $\beta$ . This is fundamentally different from the Taylor-series expansions in BV-OLS which takes expansions around the “means” of the underlying *variables*.

because the higher-order terms are empirically *irrelevant*. Even though higher-order terms are correlated with the true MR terms, the econometric results here indicate the higher-order terms are uncorrelated with the observed first-order terms ( $MR_{ij}^e$ ), consistent with little estimation bias from BV-OLS.

## 8. Conclusions and Directions for Future Research

Three years ago, theoretical foundations for the gravity equation in international trade were enhanced to recognize the *systematic bias* in coefficient estimates of bilateral trade-cost variables from omitting theoretically-motivated “multilateral (price) resistance” (MR) terms. Anderson and van Wincoop (2003) demonstrated that (i) consistent and efficient estimation of the bilateral gravity equation’s coefficients in an N-region world required custom programming of a nonlinear system of trade and price equations, (2) even if unbiased estimates of gravity equation coefficients could be obtained using fixed effects, general equilibrium comparative statics still required estimation of the full nonlinear system, and (3) the model could be applied to resolve McCallum’s “border puzzle.”

This paper has attempted to make three potential contributions. First, we have demonstrated that first-order log-linear Taylor series expansions of the nonlinear system of price equations (around two economically-different “centers”) suggest two alternative OLS log-linear specifications that introduce theoretically-motivated *exogenous* MR terms (with or without GDP-share weights). Both specifications demonstrate clearly why the “atheoretical” remoteness terms included in numerous earlier OLS specifications, such as McCallum (1995), yielded imprecise gravity-equation coefficient estimates. For tractability, we show using the same Canadian-U.S. data set as in McCallum (1995), Anderson and van Wincoop (2003) and Feenstra (2004) and using Monte Carlo simulations that our approach – BV-OLS – yields virtually identical trade-cost coefficient estimates as with fixed effects or the Anderson-van Wincoop (A-vW) technique, and demonstrate the bias introduced when either ignoring the multilateral resistance terms or proxying for them with atheoretical “remoteness” measures.

Second, the Taylor-series expansions allow one to solve for the general equilibrium comparative statics analytically, avoiding nonlinear estimation procedures. We apply our approach to the same Canadian-U.S. data set and calculate virtually identical Canadian and U.S. comparative static “border effects” as in A-vW. Moreover, recognizing that our BV-OLS estimates of the *region-specific* multilateral-resistance terms are just “approximations,” we demonstrate a simple two-step fixed-point iteration process that can generate *identical* MR terms as A-vW without any nonlinear least squares estimation. Thus, initial estimates of the MR terms from BV-OLS can be used to estimate more precisely how the multilateral resistance terms influence comparative-static effects.

Third, since the gravity equation has been used typically to examine the determinants of bilateral *world* (intra- and inter-continental international) trade flows, we show that our approach works in this setting as well. Using Monte Carlo simulations for a world economy, we show that the bias introduced by our approach is even less than in the intra-continental setting. This suggests that – for the context in which the gravity model is most frequently used – a log-linear approximation works even better. We demonstrate theoretically (in an appendix) the how the higher-order terms – variances and covariances of GDP shares and trade costs – potentially influence the results, and provide econometric evidence supporting the empirical *irrelevance* of higher-terms. This suggests that BV-OLS works well empirically because – for many practical international trade contexts – the underlying curvilinear system of equations is likely quite “flat.”

There are several directions to take future work. First, one of the benefits of BV-OLS over fixed effects is that BV-OLS allows direct estimation of the coefficients of region-specific variables. Future work could explore the consistency of bilateral trade-cost variables’ coefficient estimates under the two approaches, enabling researchers to examine the effects of region-specific variables precluded under region-specific fixed effects.

Second, since BV-OLS offers only a log-linear approximation of nonlinear MR terms, further exploration of the properties of the approximation are warranted in other contexts. BV-OLS has the potential to be used in a wide array of policy contexts because of estimation simplicity. However, the precision of estimates of MR terms for policy analysis is critical and necessitates more studies comparing estimates of MR terms from BV-OLS and A-vW. For example, in the context of the world economy, the creation of an economic integration agreement of a small country with a group of countries will likely influence dramatically its multilateral resistance level and the consequently comparative-static effects for this small country. The non-linearity of the system plays a more important role in this context – relative to the context here estimating only *average* country effects. Future research on individual EIAs will need to address this issue in more detail.

Third, and relatedly, the robustness analysis suggested that BV-OLS works potentially even better in the context of intra- *and* inter-continental trade flows, compared to intra-continental trade flows (using identical parameter settings). The two contexts differ in economic “density”; economic activity per square mile is much higher intra-continentially than inter-continentially. Moreover, differences in economic density are likely to influence the relative performance of BV-OLS because of the role of covariances of GDPs and bilateral distances in the second-order terms in BV-OLS. This suggests that future work should explore the role of economic density in BV-OLS in more analytical detail.

TABLE 1  
Estimation Results

Parameters	(1) OLS w/o MR Terms	(2) A-vW NLLS-2	(3) A-vW NLLS-3	(4) BV-OLS	(5) Fixed Effects	(6) A-vW NLLS-2a	(7) A-vW NLLS-2b
$-\rho(\sigma-1)$	-1.06 (0.04)	-0.79 (0.03)	-0.82 (0.03)	-1.26 (0.04)	-1.25 (0.04)	-0.92 (0.03)	-1.15 (0.04)
$-\alpha(\sigma-1)$	-0.71 (0.06)	-1.65 (0.08)	-1.59 (0.08)	-1.53 (0.07)	-1.54 (0.06)	-1.65 (0.07)	-1.67 (0.07)
Avg. Error Terms							
US-US	-0.21	0.06	0.06	-0.01	0.00	0.05	0.04
CA-CA	1.95	-0.17	-0.02	0.03	0.00	-0.22	-0.32
US-CA	0.00	-0.05	-0.04	0.01	0.00	-0.04	-0.02
R <sup>2</sup>	0.42	n.a.	n.a.	0.52	0.66	n.a.	n.a.
No. of obs.	1,511	1,511	1,511	1,511	1,511	1,511	1,511

Numbers in parentheses are standard errors of the estimates.

TABLE 2  
Ratios of Average  $P^{\sigma-1}$  with (BB) and without (NB) Border Barriers

	$(P^{\sigma-1}/P^{*\sigma-1})_{US}$	$(P^{\sigma-1}/P^{*\sigma-1})_{CA}$
A-vW 2-country NLLS	1.02	2.08
A-vW Multi-country NLLS	1.12	2.44
BV-OLS	1.09	2.39

TABLE 3  
Impact of Border Barriers on Bilateral Trade

	US-US	CA-CA	US-CA
(1) A-vW Two-country NLLS			
Ratio BB/NB	1.05 (0.01)	4.31 (0.34)	0.41 (0.02)
- due to bilateral resistance	1.0 (0.0)	1.0 (0.0)	0.19 (0.01)
- due to multilateral resistance	1.05 (0.01)	4.31 (0.34)	2.13 (0.09)
(2) A-vW Multi-country NLLS			
Ratio BB/NB	1.25 (0.02)	5.96 (0.42)	0.56 (0.03)
- due to bilateral resistance	1.0 (0.0)	1.0 (0.0)	0.20 (0.02)
- due to multilateral resistance	1.25 (0.02)	5.96 (0.42)	2.72 (0.12)
(3) BV-OLS			
Ratio BB/NB	1.20 (0.01)	5.73 (0.45)	0.57 (0.01)
- due to bilateral resistance	1.0 (0.0)	1.0 (0.0)	0.22 (0.02)
- due to multilateral resistance	1.20 (0.01)	5.73 (0.45)	2.62 (0.11)

Numbers in parentheses are standard errors.

TABLE 4  
Impact of Borders on Intranational Trade Relative to International Trade

	Canada	U.S.
(1) A-vW Two-country NLLS	10.50 (1.16)	2.56 (0.13)
(2) A-vW Multi-country NLLS	10.70 (1.06)	2.24 (0.12)
(3) BV-OLS <sup>1</sup>	10.07 (1.05)	2.11 (0.07)

Numbers in parentheses are standard errors.

<sup>1</sup>Using only 40 regions – excluding the 41<sup>st</sup> “aggregate” state – yields a Canadian (U.S.) estimate of 9.87 (2.15). Using all 51 U.S. states (including the District of Columbia), rather than the 41<sup>st</sup> aggregate state yields a Canadian (U.S.) estimate of 10.67 (1.59).

TABLE 5  
 Monte Carlo Simulations: Scenario 1  
 True Border Coefficient = -1.65  
 True Distance Coefficient = -0.79

Specification	Coefficient Estimate Average	Standard Deviation	Fraction within 2 Standard Errors of True Value
(1) McCallum			
Border	-0.789	0.026	0.000
Distance	-0.562	0.017	0.000
(2) OLS w/Atheoretical Remoteness Terms			
Border	-0.804	0.026	0.000
Distance	-0.541	0.019	0.000
(3) A-vW			
Border	-1.650	0.051	0.973
Distance	-0.789	0.034	0.950
(4) Fixed Effects			
Border	-1.650	0.033	0.967
Distance	-0.790	0.033	0.943
(5) BV-OLS			
Border	-1.643	0.033	0.985
Distance	-0.802	0.020	0.978

TABLE 6  
 Monte Carlo Simulations: Scenario 2  
 True Border Coefficient = -1.54  
 True Distance Coefficient = -1.25

Specification	Coefficient Estimate Average	Standard Deviation	Fraction within 2 Standard Errors of True Value
(1) McCallum			
Border	-0.655	0.025	0.000
Distance	-0.952	0.017	0.000
(2) OLS w/Atheoretical Remoteness Terms			
Border	-0.664	0.026	0.000
Distance	-0.940	0.019	0.000
(3) A-vW			
Border	-1.540	0.051	0.977
Distance	-1.250	0.034	0.950
(4) Fixed Effects			
Border	-1.540	0.033	0.988
Distance	-1.250	0.033	0.942
(5) BV-OLS			
Border	-1.529	0.033	0.999
Distance	-1.276	0.021	0.996

## REFERENCES

- Aitken, Norman D. "The Effect of the EEC and EFTA on European Trade: A Temporal Cross-Section Analysis." *American Economic Review* 5 (December 1973): 881-892.
- Anderson, James E. "A Theoretical Foundation for the Gravity Equation." *American Economic Review* 69, no. 1 (March 1979): 106-116.
- Anderson, James E., and van Wincoop, Eric. "Gravity with Gravitas: A Solution to the Border Puzzle." *American Economic Review* 93, no. 1 (March 2003): 170-192.
- Anderson, James E., and van Wincoop, Eric. "Trade Costs." *Journal of Economic Literature* 62, no. 3 (September 2004): 691-751.
- Anderson, Michael A., and Smith, Stephen L.S. "Canadian Provinces in World Trade: Engagement and Detachment." *Canadian Journal of Economics* 32, no. 1 (1999a): 23-37.
- Anderson, Michael A., and Smith, Stephen L.S. "Do National Borders Really Matter? Canada-US Regional Trade Reconsidered." *Review of International Economics* 7, no. 2 (199b): 219-227.
- Baier, Scott L., and Bergstrand, Jeffrey H. "The Growth of World Trade: Tariffs, Transport Costs, and Income Similarity." *Journal of International Economics* 53, no. 1 (February 2001): 1-27.
- Balistreri, Edward J., and Hillbery, Russell H. "Structural Estimation and the Border Puzzle." Working paper, U.S. International Trade Commission, July 2004.
- Bergstrand, Jeffrey H. "The Gravity Equation in International Trade: Some Microeconomic Foundations and Empirical Evidence." *Review of Economics and Statistics* 67, no. 3 (August 1985): 474-481.
- Deardorff, Alan. "Does Gravity Work in a Neoclassical World?" In *The Regionalization of the World Economy*, edited by Jeffrey A. Frankel. Chicago: The University of Chicago Press, 1998.
- Eaton, Jonathan, and Kortum, Samuel. "Technology, Geography, and Trade." *Econometrica* 70, no. 5 (September 2002): 1741-1779.
- Eichengreen, Barry, and Irwin, Douglas. "The Role of History in Bilateral Trade Flows." In *The Regionalization of the World Economy*, edited by Jeffrey A. Frankel. Chicago: The University of Chicago Press, 1998.
- Felbermayr, Gabriel J., and Kohler, Wilhelm, "Exploring the Intensive and Extensive Margins of World Trade." Working Paper, European University Institute and Eberhard Karls University, August 2004.
- Feenstra, Robert C. *Advanced International Trade: Theory and Evidence*. Princeton, NJ: Princeton University Press, 2004.
- Gerald, Curtis F., and Wheatley, Patrick O. *Applied Numerical Analysis*, 4<sup>th</sup> ed. Reading, MA: Addison-Wesley, 1990.
- Helliwell, John F. "Do National Boundaries Matter for Quebec's Trade?" *Canadian Journal of*

- Economics* 29, no. 3 (1996): 507-522.
- Helliwell, John F. "National Borders, Trade and Migration." *Pacific Economic Review* 2, no. 3 (1997): 165-185.
- Helliwell, John F. *How Much Do National Borders Matter?* Washington, DC: Brookings Institution, 1998.
- Helpman, Elhanan, and Krugman, Paul. *Market Structure and Foreign Trade*. Cambridge, MA: MIT Press, 1985.
- Judd, Kenneth L. *Numerical Methods in Economics*. Cambridge, MA: MIT Press, 1998.
- Linnemann, Hans. *An Econometric Study of International Trade Flows*. Amsterdam: North-Holland, 1966.
- McCallum, John. "National Borders Matter: Canada-U.S. Regional Trade Patterns." *American Economic Review* 85, no. 3 (June 1995): 615-623.
- Nirenberg, L. *Functional Analysis: Notes by Lesley Sibner*. Courant Institute of Mathematical Science, New York University, 1975.
- Rose, Andrew, and van Wincoop, Eric. "National Money as a Barrier to International Trade: The Real Case for Currency Union." *American Economic Review Papers and Proceedings* 91, no. 2 (May 2001): 386-390.
- Sapir, Andre. "Trade Benefits under the EEC Generalized System of Preferences." *European Economic Review* 15 (1981): 339-355.
- Tinbergen, Jan. *Shaping the World Economy*. New York: The Twentieth Century Fund, 1962.

## Appendix A

The technique described in the paper, BV-OLS, yields virtually identical gravity equation coefficient estimates to those estimated using region-specific fixed effects (which are unbiased estimates). However, fixed effects cannot be used to generate general equilibrium comparative statics. Because BV-OLS yields linear approximations, it does not provide precise estimates of the region-specific multilateral resistance (MR) terms (with or without borders). However, one need not estimate the entire system of equations using custom nonlinear least squares to generate the exact same estimates of the MR terms as with A-vW's NLLS estimation. Given initial estimates of the MR terms using BV-OLS, a version of fixed-point iteration can be used to generate *identical* MR terms as under the NLLS technique, and fixed-point iteration is computationally much less intensive than the A-vW NLLS technique. In particular, even though the system of equations that determines the MR terms is non-linear, our fixed-point iteration method does not require computation of the Jacobian of the system of equations, nor does it require that the inverse of the Jacobian exists. We show that our approach requires nothing more than simple matrix manipulation in *STATA*, *GAUSS*, or any similar matrix programming language.

The approach can be calculated for MR terms with or without borders; for demonstration here, we assume borders are present. First, BV-OLS yields estimates of multilateral resistance terms  $P_i^{1-\sigma}$  for  $i=1, \dots, N$  regions (with borders) based upon the log-linear approximation. Denote  $V_0$  as the  $N \times 1$  vector of these  $P_i^{1-\sigma}$  terms and  $V_0^-$  as the  $N \times 1$  vector of their inverses ( $P_i^{\sigma-1}$ ). The functional equation we solve is  $f(V) = V - BV$ , where  $B$  is an  $N \times N$  matrix of GDP-share-weighted trade costs where each element,  $b_{ij}$ , equals  $\theta t_{ij}^{1-\sigma}$ , where  $t_{ij}$  are defined in section 2. Evaluated at the equilibrium values of the MR terms,  $V^E$  and  $V^E$ , then  $f(V^E) = V - BV^E = 0$ .

The fixed-point iteration method we use has essentially only two steps. First, use coefficient estimates from BV-OLS to construct the matrix  $B$  and use BV-OLS estimates of  $P_i^{1-\sigma}$  ( $P_i^{\sigma-1}$ ) to construct the initial value of  $V_0$  ( $V_0^-$ ). Second, compute  $V_{k+1}$  according to:

$$V_{k+1} = zBV_k^- + (1-z)V_k \tag{A1}$$

starting at  $k = 0$  until successive approximations are less than a predetermined value (e.g.,  $1 \times 10^{-9}$ ) of  $\varepsilon = \max|V_{k+1} - V_k|$ , where  $\max|V_{k+1} - V_k|$  is the largest error approximation and  $z$  is a damping factor with  $z \in (0,1)$ . The estimated  $V_{k+1}$  satisfying this second step is *identical* to the  $V$  estimated using A-vW's custom NLLS estimation.

The remainder of this appendix proves in mathematical detail why this version of the fixed-point iteration converges to a solution. First, the standard approach for fixed-point iteration is to start with an initial guess  $V_0$  and iterate on:

$$V_{k+1} = BV_k^- \tag{A2}$$

starting at  $k=0$ . The above equation converges as long as  $BV$  is a contraction map; that is, a necessary condition for a fixed-point iteration to converge is that – for each row of the Jacobian of  $BV$  – the sum of the absolute values of each element is less than unity, cf., Gerald and Wheatley (1990). This condition is unlikely to hold in general and it certainly does not hold for the McCallum-A-vW-Feenstra data. Even if it is a contraction map, it may not be the case that iterating induces convergence to the fixed point.

To see why this iteration process will not work in this context, consider a simple univariate

mapping of:

$$v = (1/2)v^{-1} \quad (\text{A3})$$

Trivially, the fixed point of this mapping is  $v^E = 1/\sqrt{2}$ . Clearly, the Jacobian satisfies the necessary condition for the fixed-point iteration to converge. However, with any initial guess of  $v_0 \neq 1/\sqrt{2}$ , the iteration produces a periodic cycle. For example, choose  $v_0 = 2$  and the “solution” iterates between

$$v_i = \begin{cases} 1/4 & i \text{ odd} \\ 2 & i \text{ even} \end{cases}$$

and convergence does not obtain. To induce convergence in this system, we simply add a damping factor  $z$  ( $z = 0.5$ ) and iterate on:

$$v_{k+1} = z(1/2)v_k^{-1} + (1-z)v_k \quad (\text{A4})$$

With an initial estimate of  $v_0 = 2$  for  $k=0$ , iterating on (A4) causes convergence of  $v$  to the true value (within ten decimal places) in three iterations.

Consequently, to induce convergence in our context, we introduce the damping factor  $z$ , where  $z \in (0,1)$ , and (A2) becomes:

$$V_{k+1} = zBV_k^{-1} + (1-z)V_k \quad (\text{A5})$$

Note this implies that  $V_{k+1} = V_k - z f(V_k)$ . For an initial guess in the range of  $V^E$ , the fixed-point iteration will converge to  $f(V^E) = 0$  if  $z$  is contracting (since  $z$  is less than unity), cf., Nirenberg (1975). Thus, for the class of models discussed in A-vW the solution to the price terms can be obtained by fixed-point iteration with a damping factor of  $z \in (0,1)$ . Note how similar this is to the Gauss-Newton iteration scheme discussed in Judd (1998). Unlike the Gauss-Newton iteration, this procedure does not require computing the Jacobian or its inverse, if the latter exists.

We applied this procedure to the McCallum-A-vW-Feenstra Canadian-U.S. data set, using a stopping rule of  $\epsilon < 1 \times 10^{-9}$  for all elements of  $V$ . If we use the parameter values in A-vW of  $\rho(1-\sigma) = -0.79$  and  $\alpha(1-\sigma) = -1.65$ , convergence is achieved after 25 iterations (for both cases, with and without the border) and the correlation of the multilateral resistance terms with the multilateral resistance terms constructed by A-vW is 1.0 (reported to seven decimal places). If we use the parameter values in BV-OLS of  $\rho(1-\sigma) = -1.25$  and  $\alpha(1-\sigma) = -1.54$ , convergence is achieved after 21 iterations (for both cases, with and without the border) and the correlation of the multilateral resistance terms with the multilateral resistance terms constructed by the A-vW NLLS methodology is 1.0 (reported to seven decimal places). Given that this methodology replicates perfectly the MR terms calculated by A-vW, the comparative statics are identical to those reported by A-vW (2003, 187).

## Appendix B

In this appendix, we take a *second-order* log-linear Taylor-series expansion of equation (14), centered around a symmetric world (eq. (25)). We report only the first set of derivations, akin to equation (27) in section II.B.:

$$\begin{aligned}
& P^{1-\sigma} + (1-\sigma)P^{1-\sigma}(\ln P_i - \ln P) \\
& \quad + \frac{1}{2}(1-\sigma)^2 P^{1-\sigma}(\ln P_i - \ln P)^2 \\
& = \sum_{j=1}^N \left[ \theta P^{-(1-\sigma)} t^{1-\sigma} - (\theta P^{-(1-\sigma)} t^{1-\sigma})(1-\sigma)(\ln P_j - \ln P) \right. \\
& \quad + (\theta P^{-(1-\sigma)} t^{1-\sigma})(\ln \theta_j - \ln \theta) + (\theta P^{-(1-\sigma)} t^{1-\sigma})(1-\sigma)(\ln t_{ij} - \ln t) \\
& \quad - \frac{1}{2}(1-\sigma)^2 (\theta P^{-(1-\sigma)} t^{1-\sigma})(\ln P_j - \ln P)^2 \\
& \quad + \frac{1}{2}(\theta P^{-(1-\sigma)} t^{1-\sigma})(\ln \theta_j - \ln \theta)^2 \\
& \quad + \frac{1}{2}(1-\sigma)^2 (\theta P^{-(1-\sigma)} t^{1-\sigma})(\ln t_{ij} - \ln t)^2 \\
& \quad - 2 \cdot \frac{1}{2}(1-\sigma)(\theta P^{-(1-\sigma)} t^{1-\sigma})(\ln P_j - \ln P)(\ln \theta_j - \ln \theta) \\
& \quad - 2 \cdot \frac{1}{2}(1-\sigma)^2 (\theta P^{-(1-\sigma)} t^{1-\sigma})(\ln P_j - \ln P)(\ln t_{ij} - \ln t) \\
& \quad \left. + 2 \cdot \frac{1}{2}(1-\sigma)(\theta P^{-(1-\sigma)} t^{1-\sigma})(\ln \theta_j - \ln \theta)(\ln t_{ij} - \ln t) \right] \tag{B1}
\end{aligned}$$

A comparison of equation (B1) with equation (27) shows that the RHS of the former equation includes three additional terms reflecting variances of the (endogenous) price term and of the (exogenous) GDP shares and trade costs, and three additional terms reflecting covariance among the (endogenous) price terms and (exogenous) GDP shares and trade costs. One cannot solve this equation analytically.

Figure 1a: Estimates of Border Bias

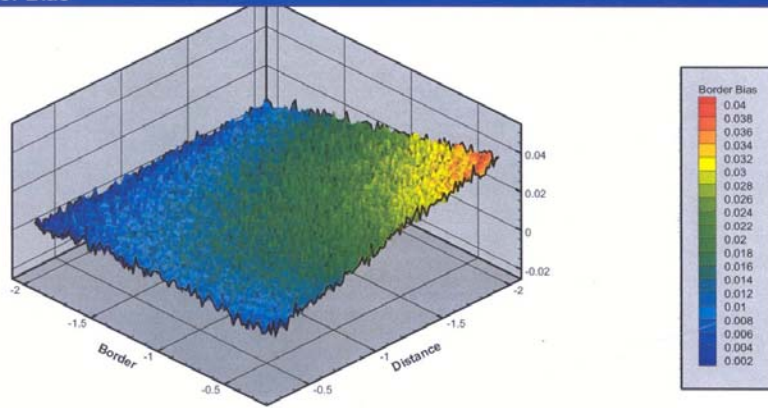

Figure 1b: Fraction of Estimates within Two Standard Errors

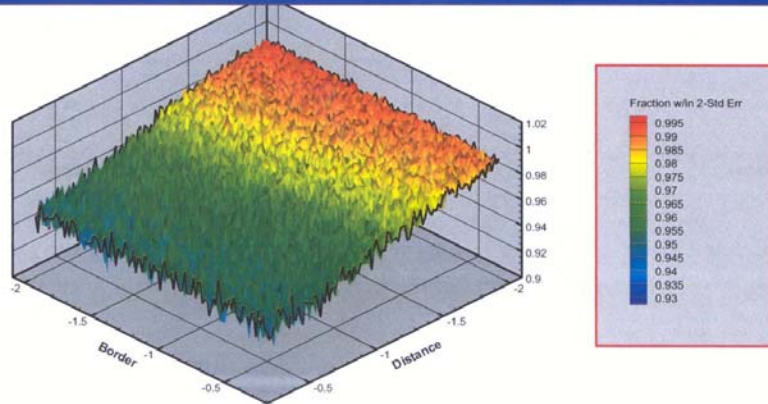

Figure 2a: Estimates of Distance Bias

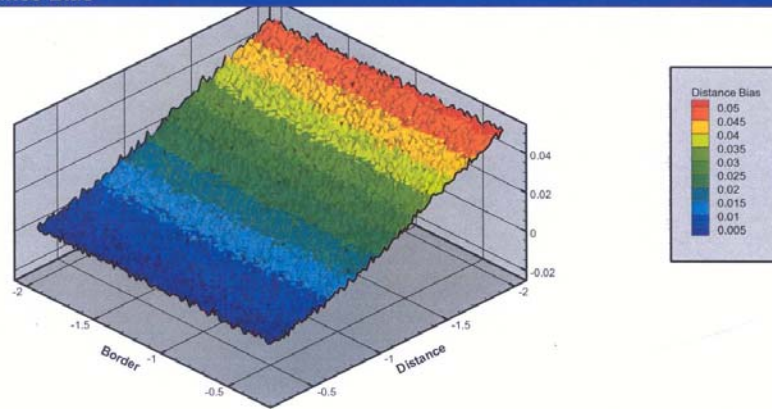

Figure 2b: Fraction of Estimates within Two Standard Errors

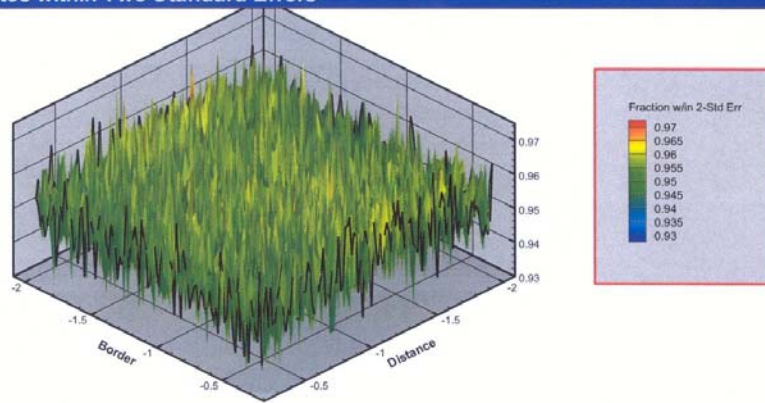

Figure 3a: Estimates of Border Bias

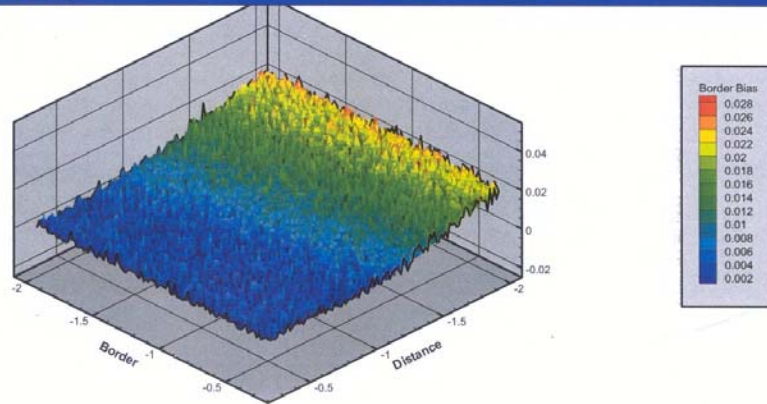

Figure 3b: Fraction of Estimates within Two Standard Errors

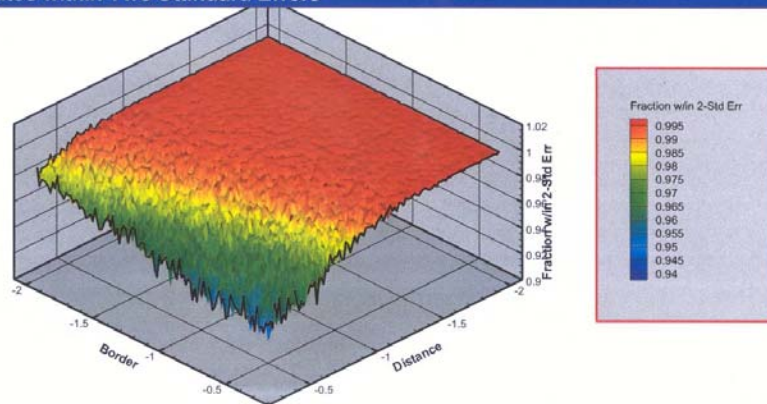

Figure 4a: Estimates of Distance Bias

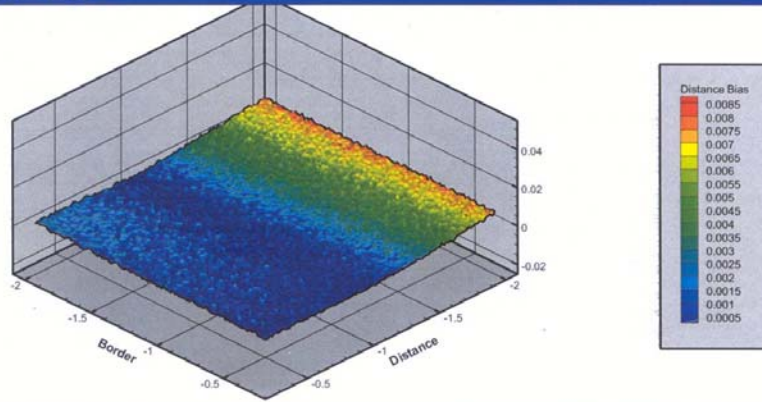

Figure 4b: Fraction of Estimates within Two Standard Errors

