

Passivity Index for Switched System Design

Technical Report of the ISIS Group
at the University of Notre Dame
ISIS-09-002
May, 2009

Michael J. McCourt and Panos J. Antsaklis
Department of Electrical Engineering
University of Notre Dame
Notre Dame, IN 46556

Interdisciplinary Studies in Intelligent Systems

Passivity Index for Switched System Design

Michael J. McCourt and Panos J. Antsaklis

Department of Electrical Engineering

University of Notre Dame

Notre Dame, IN 46556

e-mail: `mmccour1@nd.edu`, `antsaklis.1@nd.edu`

Abstract

This paper presents a framework for control design of general nonlinear switched systems using passivity and two passivity indexes. Background material will be presented on traditional passivity for continuously varying systems, the concept of a passivity index, and passivity theory for switched systems. The passivity index concept will then be generalized to apply to switched systems to measure the degree of passivity in a system. It will be shown that when the passivity indexes exist, controllers can be designed to yield stable systems using the indexes. Two special cases are given for designing controllers for linear switched systems. The final result will then be presented showing that the passivity indexes can be used to design controllers for general nonlinear switched systems.

Contents

1	Introduction	3
2	Background Material	4
2.1	Passive Systems	4
2.2	Passivity Index	5
2.3	Passive Switched Systems	7
3	Passivity Index for Switched Systems	8
4	Design with Passivity Index	10
4.1	Linear System Design	10
4.2	Nonlinear Control Design	13
5	Conclusion	15
	Appendix A - Index Examples	16
	Appendix B - Passive Switched Systems Review	17
	Appendix C - Interconnection Proofs	21

1 Introduction

Traditional passive systems theory is a powerful tool for system analysis and control design [1],[2]. Its origins are in electrical circuit theory where networks of passive circuit components were known to be stable in various configurations. These components were often linear, but passivity can be applied to general nonlinear systems. Although Lyapunov theory provides more general stability results for nonlinear systems, passivity gives a similarly intuitive approach. The real strength in using this theory is that passivity is a property that is preserved when systems are interconnected in parallel or feedback. Using these results, large-scale systems can be shown to be stable by verifying passive definitions for each system component and by following simple interconnection rules.

Passivity has been applied to many systems using a traditional notion of energy. Examples include simple systems such as electrical circuits and mass-spring-dampers. More complex applications include robotics [3], distributed systems [4], and chemical processes [5]. It has also been applied to networked control systems with delays where systems can be stabilized using a wave variable transformation [6]. In these more general cases, passivity can be applied even when there isn't a traditional notion of energy, but rather a generalized energy. This generalized energy can be defined for each specific system using an energy storage function. When a storage function exists and the energy stored in a system can be bounded above by the energy supplied to the system, the system is passive.

Although passivity has traditionally been applied to continuous time nonlinear systems, there is a natural extension to switched systems. Using this expanded definition, a much larger class of systems can be identified as passive and controlled using passivity techniques. This includes systems with naturally hybrid dynamics, complex systems that are modeled using switched systems, and systems with multiple switching controllers.

Traditional passivity is only a binary characterization of system behavior based on whether or not that system dissipates sufficient energy. However, there are systems that dissipate significantly more energy than is required to maintain passivity. Simply terming these systems "passive" does not describe the systems' behavior well enough. Likewise, there are non-passive systems that would become passive with a simple loop transformation. Knowing the type and magnitude of the loop transformation would help in designing a stable system. In both cases, this information can be presented in the form of a passivity index. Using a passivity index provides more information for control design.

The remainder of this report will be concerned with presenting two passivity indexes for switched systems. First, background material on passivity and the concept of a passivity index for continuously varying systems will be covered. Then the definition of passive switched systems will be reviewed. After the generalized passivity index for switched systems is presented, theorems using the index will be given to guide the control design of general (not necessarily passive) switched systems.

2 Background Material

2.1 Passive Systems

Passivity is a characterization of dynamic systems based on energy dissipation. It is typically shown by defining an energy storage function and showing that the energy stored during any time interval is bounded above by the energy supplied to the system. The energy supplied to the system takes the form of the inner product of the system input and output and may not correspond to a traditional notion of energy. This generalized energy function must be constrained to be positive definite.

Definition 1. A scalar function $V(x)$ of a vector quantity $x \in \mathbb{R}^n$ is positive definite if the following are true.

- $V(x) > 0, \forall x \neq 0$
- $V(0) = 0$

Using this generalized notion of energy, the definition of passivity can be given.

Definition 2. A system is passive if there exists a positive definite storage function $V(x)$ such that, for all $t_1 \leq t_2$,

$$\int_{t_1}^{t_2} u^T(t)y(t)dt \geq V(x(t_2)) - V(x(t_1)). \quad (1)$$

If the energy supply rate is relaxed to be any function of input and output, the passive inequality becomes the more general dissipative inequality. For further details on passivity and dissipativity, refer to [5],[7],[8].

Definition 3. A system is dissipative if there exists a positive definite storage function $V(x)$ such that, for some $\omega(u, y)$ and for all $t_1 \leq t_2$,

$$\int_{t_1}^{t_2} \omega(u, y)dt \geq V(x(t_2)) - V(x(t_1)). \quad (2)$$

Passive systems have the property that the unforced system, $u = 0$, is Lyapunov stable. Dissipative systems aren't necessarily Lyapunov stable but there exists a control input for which $\omega(u, y)$ is negative definite

The following definitions are important when analyzing the level of passivity of a system. The main reason to cover these is to discuss properties of passive systems and how to use these properties to characterize systems that lack passivity. The properties have familiar definitions for linear systems, but they have nonlinear generalizations that are equally useful.

Definition 4. The zero dynamics of a system are the state dynamics associated with the output fixed at zero,

$$\begin{aligned} \dot{x} &= f(x, u) \\ 0 &= h(x, u). \end{aligned} \quad (3)$$

Definition 5. *A system is minimum phase if its zero dynamics are Lyapunov stable in a neighborhood around the origin.*

Minimum phase linear systems are ones with all zeros located in the left half plane. Systems with non-minimum phase zeros have the distinct behavior that, when being controlled to a set-point, they initially move away from the set-point. This behavior is generalized to nonlinear systems when a given system has unstable zero dynamics. All passive systems are minimum phase.

Another important characterization of linear passive systems is that they have low relative degree. When written as a transfer function, the relative degree of the system is the difference between the denominator polynomial and the numerator polynomial. Assuming that the system is causal, the relative degree of the system cannot be negative. The relative degree of nonlinear system is as follows.

Definition 6. *The relative degree of a system is the number of times the output equation must be differentiated before the input variable appears.*

Passive systems have relative degree of zero or one. For simplicity, this will be referred to as *low relative degree* for the remainder of this paper. When either of these definitions is applied to a linear system it gives the same result as the traditional definition.

2.2 Passivity Index

The concept of a passivity index is most thoroughly covered by Bao and Lee [5]. The first index is based on the range of positive feedback gains that will passivate a system. The other is the range of feedforward gains that will passivate a system. The two are independent in the sense that knowing one index does not provide any information about the other except that the other index must exist. Both indexes are necessary to characterize the level of passivity in a system.

The two indexes are designed so that each is the largest such gain that will passivate the system and any smaller gain will also render the system passive. This means that passive systems have a positive or zero value for both indexes. Non-passive systems can have one index negative and the other positive or neither index exists. When a system has a positive value for an index, this is termed an *excess* of that particular form of passivity. Likewise a negative value for that index is termed a *shortage*.

Definition 7. *The output feedback passivity index (OFP) is shown in the following block diagram (Fig. 1). It is the largest gain that can be placed in positive feedback with a system such that the interconnected system is passive. This index is denoted $OFP(\rho)$.*

Definition 8. *The input feedforward passivity index (IFP) is shown in the following block diagram (Fig. 2). It is the largest gain that can be put in a negative parallel interconnection with a system such that the interconnected system is passive. This index is denoted $IFP(\nu)$.*

When applying the two indexes simultaneously (Fig. 3), a system is said to have $OFP(\rho)$ and $IFP(\nu)$. For examples of the two passivity indexes, refer to Appendix A.

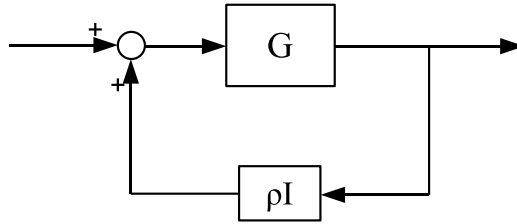

Figure 1: Positive feedback measure for OFP.

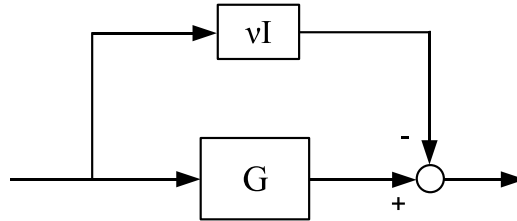

Figure 2: Negative feedback measure for IFP.

It isn't always possible to passivate a system using these two loop transformations. When a system lacks OFP it is unstable and can be made passive with negative feedback only if the system is of low relative degree and is minimum phase. Likewise, when a system lacks IFP it is non-minimum phase and can be made passive with positive feedforward only if the system is stable. This means that a system that is both unstable and non-minimum phase cannot be made passive with any combination of feedback and feedforward gains. In this case, neither index exists. In some cases it may be possible to passivate these systems with state feedback and a feedforward gain. From a design perspective, these cases are significantly different so will not be addressed in this paper.

It should be noted that there are two special cases when the system under consideration is passive. When the system is passive and has an excess of OFP, the system is output strictly passive. Likewise, if it is passive with an excess of IFP, the system is input strictly passive. Consider the following inequality:

$$\int_{t_1}^{t_2} u^T(t)y(t)dt \geq V(x(t_2)) - V(x(t_1)) + \int_{t_1}^{t_2} \nu u^T(t)u(t)dt + \int_{t_1}^{t_2} \rho y^T(t)y(t)dt. \quad (4)$$

Definition 9. A system is output strictly passive if (4) holds for $\rho > 0$ and $\nu \geq 0$.

Definition 10. A system is input strictly passive if (4) holds for $\nu > 0$ and $\rho \geq 0$.

As expected, both of these special cases of passivity describe systems that are Lyapunov stable, but output strictly passive systems have the added result that they are finite-gain \mathcal{L}_2 stable. When the inequality 4 holds without the sign constraint on ρ or ν , it is equivalent to the system being OFP(ρ) and IFP(ν).

Using the passivity indexes provides more information about a system other than the simple characterization of passive or not passive. This information can be used to define stable feedback

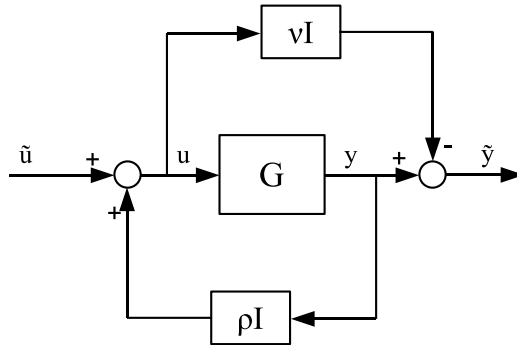

Figure 3: The system with both indexes applied. This will be referred to as the *modified system*.

loops even when the systems in the loop aren't passive. How this is done will be covered in the design section of this paper.

2.3 Passive Switched Systems

There have been a few definitions of passivity proposed for switched systems [9],[10],[11]. For an overview of these works, refer to Appendix B. The most comprehensive definition in the literature seems to be the work of Zhao and Hill [11]. In this paper, passivity for switched systems is defined and used to show that passive switched systems are stable and passivity is preserved when combined in negative feedback. The switched systems in question are in the following form with a finite number of subsystems, $i = 1, \dots, m$,

$$\begin{aligned} \dot{x} &= f_i(x, u) \\ y &= h_i(x, u). \end{aligned} \quad (5)$$

Throughout this paper, assume that the system switches a finite number of times on any finite time interval. The *switching signal* is a function of time that takes on the value of the index of the subsystem ($1, \dots, m$) that is active at each time instant. Consider the k^{th} time switching to the i^{th} subsystem. The switching signal has the value i from time t_{i_k} up to time $t_{i_{k+1}}$.

Definition 11. *Given a switched system (5), this system is passive if the following conditions are satisfied.*

1. *There exist storage functions $V_i(x)$ such that the system is passive while the i^{th} subsystem is on,*

$$\int_{t_1}^{t_2} u^T(t)y(t)dt \geq V_i(x(t_2)) - V_i(x(t_1)), \forall i. \quad (6)$$

2. *There exist cross supply rates $\omega_j^i(u, y, x, t)$ such that the j^{th} subsystem is dissipative when the i^{th} subsystem is on,*

$$\int_{t_1}^{t_2} \omega_j^i(u, y, x, t)dt \geq V_j(x(t_2)) - V_j(x(t_1)), \forall j, \forall i \neq j. \quad (7)$$

3. There exist functions $\phi_j^i(t)$ for each cross supply rate that are absolutely summable and such that

$$\omega_j^i(u, y, x, t) \leq \phi_j^i(t), \forall j \neq i. \quad (8)$$

3 Passivity Index for Switched Systems

Although passivity indexes have been defined and used for continuously varying systems, they haven't previously been applied to switched systems. This is mainly because passivity applied to switched systems is a relatively new research area. This section covers two formulations of the passive indexes for switched systems based on different assumptions about the switching behavior. It will be shown that these generalize the traditional concept of the indexes.

Any generalization of the passivity index to switched systems should maintain the precise concept of the index for continuously varying systems. When both indexes exist, the system with the appropriate gains applied (Fig. 3) should remain passive. However, there are two ways the indexes can be defined to meet these expectations. If the gains remain constant, a conservative definition of the indexes can be formed. This definition is valid for any switching signal. If the gains are allowed to be time varying, the indexes can be made much less conservative, but the switching signal must be known. The two proposed definitions will be provided. Since the first proposition is a special case of the second, after both are covered it will be shown that they meet the expected condition of the index.

Proposition 1. *Consider a switched system (5) with arbitrary switching signal. Assume the subsystems have OFP index set $\{\rho_i\}$ and IFP index set $\{\nu_i\}$. Then the switched system is OFP with index $\rho = \min\{\rho_i\}$ and IFP with index $\nu = \min\{\nu_i\}$.*

The next case to consider is when the overall switched system gains are allowed to be a function of time. The gain functions are simple, being in a piecewise constant form. The value of the gain functions at a given time is simply the values of the constant passivity indexes for the active subsystem. With a reasonable assumption, such as finite dwell time for each subsystem, the gain functions are well defined.

Using time varying gains is a more general framework than restricting the gains to be constant. However, to make use of this index requires some knowledge of the switching signal. This could be that the switching sequence is a known function of time, that it is a function of the known continuous state, or that it is a measurable discrete valued signal. The definition of the time-varying indexes is given in the following proposition.

Proposition 2. *Consider a switched system (5) with a known or measurable switching signal. Assume each subsystem i has constant OFP index ρ_i and IFP index ν_i . The i^{th} subsystem is active for the k^{th} time over an interval $[t_{i_k}, t_{i_{k+1}})$. During this time interval, the values of the indexes are the constant values of the indexes for that active switched system. The overall switched system is OFP with index $\rho(t)$ and IFP with index $\nu(t)$, where*

$$\begin{aligned} \rho(t) &= \rho_i \quad \text{and} \\ \nu(t) &= \nu_i \end{aligned} \quad (9)$$

for $t_{i_k} \leq t < t_{i_{k+1}}$.

Proof. To show that the switched system has the given passivity indexes, it is sufficient to show that the system with feedback $\rho(t)$ and feedforward $\nu(t)$ is passive. Note that the well-posedness of the feedback loop requires that $\rho(t)\nu(t) \neq 1, \forall t$.

From the modified system (Fig. 3), the following loop equations hold:

$$\begin{aligned} u &= \tilde{u} + \rho(t)y \\ \tilde{y} &= y - \nu(t)u. \end{aligned} \quad (10)$$

The conditions for the modified system to be passive will now be verified.

1. For the modified system, each subsystem is passive when active. By the choice of $\rho(t)$ and $\nu(t)$, the gains applied to each active subsystem are always less than or equal to the largest gains that will passivate each subsystem,

$$\begin{aligned} \rho(t) &\leq \rho_i, \quad \forall i, \quad \text{and} \\ \nu(t) &\leq \nu_i, \quad \forall i. \end{aligned}$$

Note that the inequality holds with strict equality for time varying gains, but the inequality is needed for constant gains.

2. The original system G satisfied the cross supply rate dissipative inequalities (7) with rates ω_j^i . To show that the modified system remains dissipative, new cross supply rates must be defined. Consider the following modified rates $\tilde{\omega}_j^i$:

$$\tilde{\omega}_j^i(u, y, x, t) = \omega_j^i\left(\frac{u + \rho y}{1 - \rho\nu}, \frac{y + \nu u}{1 - \rho\nu}, x, t\right). \quad (11)$$

Using these new rates, it can be shown that each of the subsystems of the modified system is dissipative while inactive:

$$\begin{aligned} \int_{t_1}^{t_2} \tilde{\omega}_j^i(\tilde{u}, \tilde{y}, x, t) dt &= \int_{t_1}^{t_2} \omega_j^i\left(\frac{\tilde{u} + \rho\tilde{y}}{1 - \rho\nu}, \frac{\tilde{y} + \nu\tilde{u}}{1 - \rho\nu}, x, t\right) dt \\ &= \int_{t_1}^{t_2} \omega_j^i\left(\frac{u - \rho y + \rho(y - \nu u)}{1 - \rho\nu}, \frac{y - \nu u + \nu(u - \rho y)}{1 - \rho\nu}, x, t\right) dt \\ &= \int_{t_1}^{t_2} \omega_j^i(u, y, x, t) dt \geq V_i(x(t_2)) - V_i(x(t_1)). \end{aligned}$$

3. To show that the cross supply rates satisfy the last condition of passive hybrid systems (8) it is sufficient to use the same functions $\phi_j^i(t)$,

$$\tilde{\omega}_j^i(\tilde{u}, \tilde{y}, x, t) = \omega_j^i(u, y, x, t) \leq \phi_j^i(t).$$

This shows that for all subsystems the mapping $\tilde{G} : \tilde{u} \rightarrow \tilde{y}$ is dissipative with respect to $\tilde{\omega}_j^i$ when the i^{th} subsystem is on, $\forall i \neq j$.

The conditions for the modified system to be passive are met. The original system is passive with OFP($\rho(t)$) and IFP($\nu(t)$). \square

This proof shows sufficiency for establishing the expected result, but the gains are also the largest such gains that meet this condition. Consider a switched system with the subsystems having the OFP set $\{\rho_i\}$ and IFP set $\{\nu_i\}$. Rather than the gains given by the definition, pick either one and increase it by some arbitrarily small value. For example, pick the gains during a particular active subsystem i to be $\rho(t) = \rho_i + \epsilon$ and $\nu(t) = \nu_i$ for $\epsilon > 0$. With these gains applied the system (Fig. 3), when this subsystem is active the overall system is no longer passive so the first condition (6) of the definition is no longer met.

It should be noted that both definitions place restrictions on the switched systems that can be considered. For example, if any one of the subsystems is unstable and non-minimum phase, the indexes don't exist for that subsystem and likewise for the overall switched system.

The constant indexes defined in the first proposition are a special case of these time varying indexes. In the case when little or nothing can be said about the switching signal, the more conservative constant indexes must be used. For the remainder of the paper, it is assumed that the indexes are allowed to be time varying, but the theory developed also applies in the special case of constant indexes.

4 Design with Passivity Index

Typically, passive systems are controlled by designing a passive feedback controller. The feedback invariance that passivity provides gives the immediate result that this interconnected system (Fig. 4) is passive and stable. This approach is valid when the systems in the loop have switching behavior or when they are continuously varying. For proofs that passivity is preserved when systems are connected in feedback or parallel, refer to Appendix C. When the system to be controlled is not passive, the passivity indexes can be used to design a feedback system that still renders the interconnection stable. We will first consider the case of linear switched systems and then move onto the general nonlinear case.

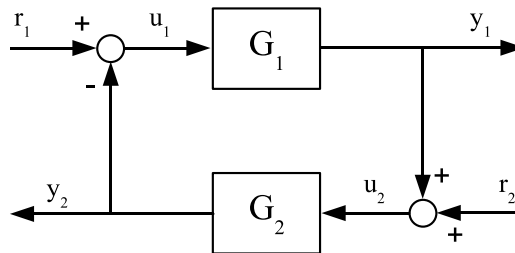

Figure 4: The feedback interconnection of two systems.

4.1 Linear System Design

Many well-studied systems have switched linear behavior or are modeled using a switched linear system model. Using the passivity indexes with linear switched systems provides an intuitive design

framework that follows from well known linear system theory. The indexes can be used to design stable, and in some cases passive, loops when a given plant may not be passive or even stable. Some of this material is a direct application of linear system theory [12],[13],[14].

A general result for switched linear systems will be presented. Then a powerful special case will be provided. The general theorem assesses stability of a loop when one of the two systems lack OFP or IFP. It is not necessary to show these four cases individually. When considering both inputs and both outputs, the interconnection has some symmetries. Only one case need be shown and the other cases follow from interchanging the definition of G_1 and G_2 and changing the sign of the indexes.

Theorem 1. Consider the feedback interconnection (Fig. 4) of two switched linear systems where all passivity indexes exist. Assume that one of the two systems lacks either OFP or IFP on some time interval. Without loss of generality, assume G_1 is passive with OFP($\rho_1(t)$) and IFP($\nu_1(t)$), and G_2 is non-passive with OFP($\rho_2(t)$) and IFP($\nu_2(t)$) where $\rho_1(t) \geq 0, \forall t$ and $\nu_2(t) < 0$ on any time interval. This interconnection is stable if the following relations hold $\forall t$:

1. $\rho_1(t) + \nu_2(t) \geq 0$ and
2. $\rho_2(t) + \nu_1(t) \geq 0$.

Proof. When considering all cases this theorem encompasses, one of the two conditions holds trivially. As the problem is stated, the second condition is immediately satisfied. When the first condition is also true, a loop transformation of the feedback interconnection is considered. It is shown that this transformed system is stable only if the original system is stable.

Define \tilde{G} to be the feedback interconnection of \tilde{G}_1 and \tilde{G}_2 which is a loop transformation (Fig. 5) from G . From the first condition, there exists a set of functions $k(t)$ such that $-\nu_2(t) \leq k(t) \leq \rho_1(t), \forall t$ to make the transformed systems \tilde{G}_1 and \tilde{G}_2 passive so that the interconnection \tilde{G} is passive and stable.

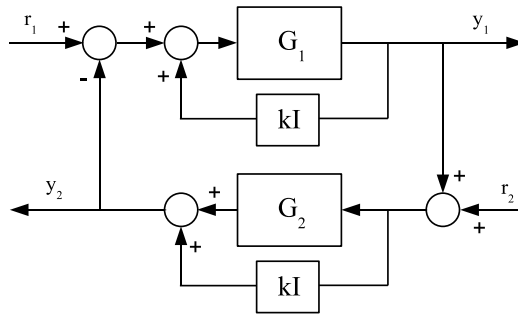

Figure 5: The loop transformation to compensate for a shortage of IFP in G_2 .

The transfer function for the original system G is

$$\begin{bmatrix} y_1 \\ y_2 \end{bmatrix} = \begin{bmatrix} (I + G_1 G_2)^{-1} G_1 & -(I + G_1 G_2)^{-1} G_1 G_2 \\ (I + G_2 G_1)^{-1} G_2 G_1 & (I + G_2 G_1)^{-1} G_2 \end{bmatrix} \begin{bmatrix} r_1 \\ r_2 \end{bmatrix}. \quad (12)$$

The transfer function for the transformed system \tilde{G} is

$$\begin{bmatrix} y_1 \\ y_2 \end{bmatrix} = \begin{bmatrix} (I + G_1 G_2)^{-1} G_1 & -(I + G_1 G_2)^{-1} G_1 (G_2 + kI) \\ (I + G_2 G_1)^{-1} (G_2 + kI) G_1 & (I + G_2 G_1)^{-1} (G_2 + kI) (I - kG_1) \end{bmatrix} \begin{bmatrix} r_1 \\ r_2 \end{bmatrix}. \quad (13)$$

These two interconnections have the same poles but different zeros. This implies that G is stable if and only if \tilde{G} is stable. As stated previously, the transformed system \tilde{G} is stable which implies that the original interconnection G is also stable. \square

This result covers the most practical control design cases when dealing with linear switched systems. For a more general result, the nonlinear framework in the next section can be used.

There is a notable special case when the passivity indexes can be used to show that the feedback loop is passive even when one of the systems in the loop is unstable. For this case, it is considered a control design example where G_1 is an unstable plant and G_2 is controller designed to passivate the loop. When G_2 is a designed controller it is assumed that there isn't a second reference input r_2 . Note that the problem formulation of this theorem is a special case of the previous theorem, but a stronger result is shown.

Theorem 2. *Consider the feedback interconnection (Fig. 4) when G_1 is a linear switched system with a shortage of OFP. Assume that G_1 is OFP($\rho_1(t)$) and IFP($\nu_1(t)$) where $\rho_1(t) < 0$ across any time interval and $\nu_1(t) \geq 0, \forall t$. G_2 is designed to be passive with IFP($\nu_2(t)$). This interconnection is passive if, $\forall t, \rho_1(t) + \nu_2(t) \geq 0$.*

Proof. By the first theorem, it is given that the system is stable. We are able to show the stronger result, passivity, in this case. Again, define G as the feedback interconnection of G_1 and G_2 ,

$$G = (I + G_1 G_2)^{-1} G_1. \quad (14)$$

By the condition in the theorem, there exists a set of functions $k(t)$ such that $-\rho_1(t) \leq k(t) \leq \nu_2(t), \forall t$. Consider the feedback interconnection \tilde{G} of \tilde{G}_1 and \tilde{G}_2 which is a loop transformation of G (Fig. 6). By the choice of $k(t)$, \tilde{G}_1 is passivated while \tilde{G}_2 remains passive. This implies that the interconnection \tilde{G} is passive.

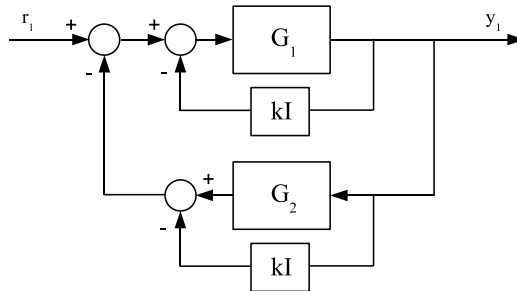

Figure 6: The loop transformation to compensate for a shortage of OFP in G_1 .

It can be shown that the mapping from r_1 to y_1 is preserved under this transformation:

$$\begin{aligned}
\tilde{G} &= (I + \tilde{G}_1\tilde{G}_2)^{-1}\tilde{G}_1 \\
&= [I + (I + kG_1)^{-1}G_1(G_2 - kI)]^{-1}(I + kG_1)^{-1}G_1 \\
&= [(I + kG_1) + G_1(G_2 - kI)]^{-1}G_1 \\
&= (I + G_1G_2)^{-1}G_1 \\
&= G.
\end{aligned}$$

By this demonstration, G is passive if and only if \tilde{G} is passive. By the range of $k(t)$ chosen previously, \tilde{G}_1 is passivated while \tilde{G}_2 remains passive. Now \tilde{G} is the feedback interconnection of two passive systems so it is likewise passive. This implies that G is passive. \square

Although both of these theorems are able to show stability of the interconnection, the second shows the stronger result that the loop is passive. This is because, in the second theorem, the loop transformation is identical to the original system whereas the loop transformation of the first theorem has different zero dynamics. The different zero dynamics are not guaranteed to be minimum phase so the interconnection is not passive in general.

4.2 Nonlinear Control Design

The final results in this paper can be applied to general nonlinear switched systems that may or may not be passive. This modeling framework is very general and guaranteeing stability of a control loop is very powerful. The main restriction with using these methods is that the two indexes must exist for each of the subsystems in the switched system. For more detail on nonlinear passive systems refer to [5],[7].

The following theorem will be given as an example of how to use the indexes when the switched system is unknown and unmeasurable. It is a special case of the final theorem in this paper where the gains are allowed to be time varying. Because it is a special case, only the final theorem will be proven.

Theorem 3. *Consider the interconnection of two switched systems (Fig. 4) where each subsystem has the following dynamics:*

$$\begin{aligned}
\dot{x}_i &= f_{ij}(x_i, u_i) \\
y_i &= h_{ij}(x_i, u_i).
\end{aligned} \tag{15}$$

Note that $i = 1, 2$ indexes the two systems in the interconnection while $j = 1, \dots, m$ indexes the active subsystem for each switched system. Assume that the systems are OFP(ρ_i) and IFP(ν_i) where $\rho_i = \min\{\rho_{ij}\}$ and $\nu_i = \min\{\nu_{ij}\}$. The interconnection is \mathcal{L}_2 stable if the following two conditions hold:

1. $\rho_1 + \nu_2 > 0$ and
2. $\rho_2 + \nu_1 > 0$.

Theorem 4. *Consider the interconnection of two switched systems (Fig. 4) where each subsystem has the dynamics previously given (15). Assume that the systems are OFP($\rho_i(t)$) and IFP($\nu_i(t)$). The interconnection is \mathcal{L}_2 stable if the following two conditions hold $\forall t$:*

1. $\rho_1(t) + \nu_2(t) > 0$ and
2. $\rho_2(t) + \nu_1(t) > 0$.

Proof. By the relationships OFP has to output strictly passive and IFP has to input strictly passive, the following dissipative inequalities hold for G_1 and G_2 , respectively:

$$\begin{aligned} u_1^T y_1 &\geq \dot{V}_1(x_1) + \rho_1 y_1^T y_1 + \nu_1 u_1^T u_1 \text{ and} \\ u_2^T y_2 &\geq \dot{V}_2(x_2) + \rho_2 y_2^T y_2 + \nu_2 u_2^T u_2. \end{aligned}$$

A new energy storage function is defined to be the sum of the two given energy storage functions,

$$V(x) = V_1(x) + V_2(x).$$

Consider the following signal relationships from the loop given:

$$\begin{aligned} u_1^T u_1 &= (r_1 - y_2)^T (r_1 - y_2) = r_1^T r_1 - 2r_1^T y_2 + y_2^T y_2, \\ u_2^T u_2 &= (r_2 + y_1)^T (r_2 + y_1) = r_2^T r_2 + 2r_2^T y_1 + y_1^T y_1, \text{ and} \\ u^T y &= (r_1^T - y_2^T) y_1 + (y_1^T + r_2^T) y_2 = r^T y. \end{aligned}$$

Define the following combined signals:

$$r = \begin{bmatrix} r_1 \\ r_2 \end{bmatrix}, \quad u = \begin{bmatrix} u_1 \\ u_2 \end{bmatrix}, \quad y = \begin{bmatrix} y_1 \\ y_2 \end{bmatrix}, \quad \text{and} \quad x = \begin{bmatrix} x_1 \\ x_2 \end{bmatrix}.$$

Summing the two dissipative inequalities and using the relationships given above, it can be shown that $\dot{V}(x)$ is bounded:

$$u^T y \geq \dot{V}_1(x_1) + \dot{V}_2(x_2) + \rho_1 y_1^T y_1 + \rho_2 y_2^T y_2 + \nu_1 u_1^T u_1 + \nu_2 u_2^T u_2 \quad (16)$$

$$r^T y \geq \dot{V}(x) + (\rho_1 + \nu_2) y_1^T y_1 + (\rho_2 + \nu_1) y_2^T y_2 + \nu_1 r_1^T r_1 - 2\nu_1 r_1^T y_2 + 2\nu_2 r_2^T y_1 + \nu_2 r_2^T r_2. \quad (17)$$

This inequality can be written in a compact form,

$$\dot{V}(x) \leq -y^T A y + r^T B y - r^T C r,$$

with the matrices defined as follows:

$$A = \begin{bmatrix} (\rho_1 + \nu_2)I & 0 \\ 0 & (\rho_2 + \nu_1)I \end{bmatrix}, \quad B = \begin{bmatrix} I & 2\nu_1 I \\ -2\nu_2 I & I \end{bmatrix}, \quad \text{and} \quad C = \begin{bmatrix} \nu_1 I & 0 \\ 0 & \nu_2 I \end{bmatrix}.$$

The following definitions can be made to bound this expression:

$$a = \min\{\rho_1 + \nu_2, \rho_2 + \nu_1\}, \quad b = \|B\|_2, \quad \text{and} \quad c = \|C\|_2,$$

where $\|\cdot\|_2$ denotes the largest singular value of the matrix. Now, a more simplified upper bound can be given:

$$\begin{aligned} \dot{V}(x) &\leq -a \|y\|_2^2 + b \|r\|_2 \|y\|_2 + c \|r\|_2^2 \\ &= -\frac{1}{2a} (a \|y\|_2 - b \|r\|_2)^2 + \frac{k^2}{2a} \|r\|_2^2 - \frac{a}{2} \|y\|_2^2 \\ &\leq \frac{k^2}{2a} \|r\|_2^2 - \frac{a}{2} \|y\|_2^2, \end{aligned}$$

where $k^2 = b^2 + 2ac$. The remaining steps are to integrate from time zero to arbitrary time T and to take the square root.

$$V(x(T)) - V(x(0)) \leq \frac{k^2}{2a} \|r_T\|_{\mathcal{L}_2}^2 - \frac{a}{2} \|y_T\|_{\mathcal{L}_2}^2$$

$$\|y_T\|_{\mathcal{L}_2} \leq \frac{k}{a} \|r_T\|_{\mathcal{L}_2} + \sqrt{\frac{2}{a} V(x(0))}.$$

This shows that the loop interconnection is \mathcal{L}_2 stable with gain less than or equal to $\frac{k}{a}$. \square

5 Conclusion

The concept of a passivity index is quite powerful. Rather than simply having a binary characterization of whether a system is passive or not, an index can provide significant detail without requiring the full dynamic system description. For general design purposes, two indexes are used. One characterizes the level of stability of the system and the other characterizes the extent to which the system is minimum phase. These values represent the level of passivity in a system and are easily used in designing stable control loops. This paper presented a few results on using the indexes to design stable feedback loops. Two results are very general and apply whenever the indexes exist for both systems in the loop. The other two results apply to linear switched systems and show Lyapunov stability or passivity in special cases.

There are two main forms of passivity indexes presented based on the assumptions made on the switched system. One is a simple generalization where the indexes are required to be constant. This one is straightforward but quite restrictive as the system indexes may be much smaller than the indexes of the particular active system. This one does carry the benefit that it can be applied without considering the particular switching sequence. In second generalization, when the switching sequence is known or measurable, the indexes can be time varying. These are much less restrictive than the constant indexes but require this additional information. For either set of assumptions, the definitions presented in this paper are the least restrictive. This allows for a large class of controllers to stabilize the system.

References

- [1] G. Zames, "On the input-output stability of time-varying nonlinear feedback systems, part one: Conditions derived using concepts of loop gain, conicity, and positivity," *Automatic Control, IEEE Transactions on*, vol. 11, no. 2, pp. 228–238, Apr 1966.
- [2] J. C. Willems, "Dissipative dynamical systems, part i: General theory," *Archive for Rational Mechanics and Analysis*, vol. 45, no. 5, pp. 321–351, Jan. 1972.
- [3] M. W. Spong, S. Hutchinson, and M. Vidyasagar, *Robot Modeling and Control*. New York: John Wiley & Sons, Inc., 2006.

- [4] N. Chopra and M. W. Spong, "Output synchronization of nonlinear systems with time delay in communication," *Decision and Control, 2006 45th IEEE Conference on*, pp. 4986–4992, Dec. 2006.
- [5] J. Bao and P. L. Lee, *Process Control*. London: Springer-Verlag, 2007.
- [6] N. Chopra, P. Berestesky, and M. W. Spong, "Bilateral teleoperation over unreliable communication networks," *Control Systems Technology, IEEE Transactions on*, vol. 16, no. 2, pp. 304–313, March 2008.
- [7] H. Khalil, *Nonlinear Systems*. Upper Saddle River, NJ: Prentice-Hall, 2002.
- [8] N. Kottenstette and P. J. Antsaklis, "Time domain and frequency domain conditions for passivity," *University of Notre Dame, ISIS Technical Report, isis-2008-002*, Nov. 2008, [Online]. Available: <http://www.nd.edu/~isis/techreports/isis-2008-002.pdf>.
- [9] M. Zefran, F. Bullo, and M. Stein, "A notion of passivity for hybrid systems," *Decision and Control, 2001. Proceedings of the 40th IEEE Conference on*, vol. 1, pp. 768–773 vol.1, 2001.
- [10] J. Zhao and D. Hill, "A notion of passivity for switched systems with state-dependent switching," *Journal of Control Theory and Applications*, vol. 4, pp. 70–75, 2006.
- [11] J. Zhao and D. J. Hill, "Dissipativity theory for switched systems," *Automatic Control, IEEE Transactions on*, vol. 53, no. 4, pp. 941–953, May 2008.
- [12] P. J. Antsaklis and A. N. Michel, *Linear Systems*. Boston, MA: Birkhauser, 2006.
- [13] K. Zhou, J. Doyle, and K. Gover, *Robust and Optimal Control*. Upper Saddle River, NJ: Prentice-Hall, 1996.
- [14] M. Green and D. J. N. Limebeer, *Linear Robust Control*. Upper Saddle River, NJ: Prentice-Hall, Inc, 1994.

Appendix A - Index Examples

In order to provide some intuition for the passivity indexes, simple linear examples are given below. These examples illustrate both excess and shortage of output feedback passivity and input feedforward passivity. The necessary conditions for each index to exist will also be reviewed. Passivity is an input-output property of systems so the following examples will be given in transfer function form.

The first two examples are cases of excess and a shortage of output feedback passivity (OFP). The index is based on the level of stability of the system in question (Fig. 1). A positive index indicates that the system is stable while a negative index indicates instability.

Example 1. Consider the passive system,

$$G = \frac{1}{s + 1}. \tag{A-1}$$

When the system has a feedback gain k applied, the combined system \tilde{G} remains passive for any k less than 1.

$$\tilde{G} = \frac{G}{1 - Gk} = \frac{1}{s + 1 - k}$$

This excess OFP passivity is denoted as $OFP(1)$.

Example 2. Consider the non-passive system,

$$G = \frac{1}{s - 2}. \quad (\text{A-2})$$

This unstable system can be made passive with feedback gain k less than -2 .

$$\tilde{G} = \frac{G}{1 - Gk} = \frac{1}{s - 2 - k}$$

This shortage of OFP passivity is denoted as $OFP(-2)$.

An unstable system can be made passive with output feedback only if the system is minimum phase and has relative degree of zero or one. If these conditions are not met, the OFP index doesn't exist. It will be seen that the IFP also doesn't exist in this case.

The next two examples are of systems that have excess or a shortage of input feedforward passivity (IFP). This index is based on the extent to which a system is minimum phase (Fig. 2). A positive index indicates that the system is minimum phase and has relative degree zero or one. A negative index indicates the system is not minimum phase.

Example 3. Consider the passive system,

$$G = \frac{2s + 3}{s + 1} = \frac{1}{s + 1} + 2. \quad (\text{A-3})$$

When the system has a negative feedforward gain k applied, the combined system \tilde{G} remains passive for any gain less than 2.

$$\tilde{G} = G - k = \frac{1}{s + 1} + 2 - k$$

This excess IFP passivity is denoted as $IFP(2)$.

Example 4. Consider the non-passive system,

$$G = \frac{1 - s}{s + 1} = \frac{2}{s + 1} - 1. \quad (\text{A-4})$$

This non-minimum phase system can be made passive with a feedforward gain less than -1 .

$$\tilde{G} = G - k = \frac{2}{s + 1} - 1 - k$$

This shortage of IFP passivity is denoted as $IFP(-1)$.

A system that is non-minimum phase or has relative degree higher than two can be made passive with positive feedforward only if the system is stable. This means that a system that is both unstable and nonminimum phase cannot be made passive with any combination of feedforward and feedback gains. In this case neither index exists.

Appendix B - Passive Switched Systems Review

This section provides a summary of recent results from passive switched system (PSS) theory. This includes significant works towards a comprehensive definition of PSS. It should be noted that there were a few papers that came out prior to these that discussed passivity applied to switched and hybrid systems when there exists a single storage function for the overall system. This framework is quite restrictive. The works covered here provide a more general definition that makes use of multiple storage functions to demonstrate passivity. This mirrors the developments of stability for switched systems using multiple Lyapunov functions. The three papers discussed here use different assumptions to show similar results. For each work, the main definition and results will be covered, and then the merits of the formulation will be discussed.

All three formulations have a few technical assumptions in common. The switched system is in the following form with a finite number of switches during any finite time interval:

$$\begin{aligned}\dot{x} &= f_i(x, u) \\ y &= h_i(x, u).\end{aligned}\tag{B-1}$$

To ensure that the origin is an equilibrium, assume that for each subsystem $f_i(0, 0) = 0$. In order to apply passivity, it is crucial that the input and output are of the same dimension. In addition to these technical assumptions, each paper makes two main assumptions. The first is the same throughout, that the active system is passive. The second assumption is much different between the three papers.

First Formulation

The first paper covering passive theory applied to switched systems was by Zefran, et. al. [9]. They were the first to define passive switched systems (PSS) using multiple storage functions. They used this definition to show stability of PSS and stability of the feedback interconnection.

Definition B-1. *The overall system is passive if for every subsystem i there exists a continuously differentiable storage function $V_i(x)$ such that the following conditions hold for nonnegative δ and ϵ and positive semidefinite $\psi(x)$.*

1. *The system is instantaneously passive while each subsystem is active,*

$$u^T y \geq \frac{dV_i}{dt} + \delta u^T u + \epsilon y^T y + \psi(x).\tag{B-2}$$

2. *When switching to each subsystem the energy that subsystem accumulated while inactive is bounded by the energy supplied during that time interval,*

$$\int_{t_{k-1}}^{t_k} u^T(t)y(t)dt \geq V_i(x(t_k)) - V_i(x(t_{k-1})).\tag{B-3}$$

This definition can be extended to strictly passive by making $\psi(x)$ positive definite. Likewise it can be extended to input strictly passive by making δ strictly positive or to output strictly passive

by making ϵ strictly positive. The authors then show that PSS with storage functions that satisfy $V_i(0) = 0$ are Lyapunov stable and that the interconnection of two PSS is once again a PSS.

This paper presents a very clear definition of passivity for switched systems and uses this definition to show the results expected of a passive system. However, the second condition of the definition is that each subsystem is passive “on average” while inactive. This condition could be made much more general. Although the given definition is sufficient to guarantee the expected results for a PSS, there are many other systems that would be considered passive by a more general definition.

Second Formulation

This formulation by Zhao and Hill [10] is more general than the previous work of Zefran, et al. In this paper, they introduce a new definition of passivity with a relaxed set of assumptions. With these assumptions they are still able show stability. However, they do not discuss passivity of the negative feedback interconnection. Overall, their presentation is clear and their proof techniques are precise.

The modification they made from previous work is to count energy accumulated while a subsystem is inactive at a different, typically reduced, rate than when the subsystem is active. While the system is inactive, the energy storage function varies based on the state dynamics which are defined by the active subsystem. This amounts to each inactive system having a reduced “imported energy” from the active system. With this adjustment, each subsystem can tolerate a larger energy supply $u^T y$ and still maintain passivity. To define this reduced storage rate, they introduce two sets of functions. One set of functions $\alpha_{ji}(t, s) : \mathbb{R}^+ \times \mathbb{R}^+ \rightarrow \mathbb{R}^+$ are such that each $\alpha_{ji}(t, s)$ is nondecreasing with respect to the second variable and $\alpha_{jj}(t, s) = s$. These functions are also denoted $\alpha_{jit}(s)$. The second set of functions $\gamma_j(s)$ must satisfy $\gamma_j(0) = 0$. With these functions, they present their definition.

Definition B-2. *A switched system is passive with a set of storage functions $V_i(x)$ and functions α_{jit} , γ_j such that the following statements are true.*

1. *The energy a system has accumulated while inactive is bounded,*

$$V_i(x(t_2)) \leq \alpha_{ji(t_2-t_1)}(V_i(x(t_1))) + \int_{t_1}^{t_2} u^T y dt. \quad (\text{B-4})$$

2. *The composition of these functions α_{jit} is bounded,*

$$\alpha_{ji_1\tau_1} \circ \alpha_{ji_2\tau_2} \circ \dots \circ \alpha_{ji_k\tau_k}(t) \leq \gamma_j(t). \quad (\text{B-5})$$

It is explicitly shown that when the system stays in a single subsystem, the first condition reduces to the traditional definition of passivity (1). Using this definition, the authors show that passive switched systems with storage functions such that $V_i(0) = 0$ have a Lyapunov stable equilibrium point.

Although the presentation of the definitions, theorems, and proofs is clear, the authors don’t discuss the significance of the functions defined. There doesn’t appear to be any method to determine the functions or to determine if they even exist. These issues cause this formulation to be

difficult to apply. An additional issue is that this paper doesn't cover whether this definition of passivity is preserved under parallel or negative feedback interconnection. If this property doesn't hold, this definition is only valid to show stability of a PSS which could have already have been shown by Lyapunov stability results for switched systems. These weaknesses are addressed in the authors' later work.

Third Formulation

This last formulation, also by Zhao and Hill [11], is more general than the one proposed by Zefran, et. al. and is conceptually equivalent to the previous formulation of Zhao and Hill. They still show stability of PSS with a different set of relaxed assumptions. The main difference is that, while the previous formulation defined an "exported energy" from the active subsystem to each of the inactive subsystems, this formulation defines two different supply rates for each subsystem. One rate is the traditional passive supply rate $u^T y$ that is valid while the subsystem is active and the other is a general dissipative rate that is valid when the subsystem is inactive. This dissipative energy supply rate is typically reduced while a system is inactive. Conceptually, reducing the energy supplied is equivalent to reducing the energy stored when the system is inactive.

The paper first introduces the generalized notion of passivity, dissipativity. This takes the same form as passivity, but rather than using the supply rate $u^T y$ it uses any function ω of the input and output,

$$\omega(u, y) \geq \frac{dV_i}{dt} + \delta u^T u + \epsilon y^T y, \quad (\text{B-6})$$

where the constants δ and ϵ are nonnegative.

This notion is more general than passivity but a dissipative system is only stable for a certain class of allowable inputs which may not include the input, $u = 0$, which would imply Lyapunov stability. The definition of passivity given for switched systems uses this definition of dissipative systems.

Definition B-3. *A switched system is passive if there exists storage functions $V_i(x)$ such that the following conditions hold for nonnegative δ and ϵ .*

1. *The system is passive while each subsystem is active,*

$$u^T y \geq \frac{dV_i}{dt} + \delta u^T u + \epsilon y^T y. \quad (\text{B-7})$$

2. *Each subsystem is dissipative during its inactive time,*

$$\omega(u, y) \geq \frac{dV_i}{dt} + \delta u^T u + \epsilon y^T y. \quad (\text{B-8})$$

3. *There exist functions ϕ_j^i for each cross supply rate that are absolutely summable and such that*

$$\omega_j^i(u, y, x, t) \leq \phi_j^i(t), \quad \forall j \neq i. \quad (\text{B-9})$$

With this new definition of passivity, the authors show that PSS with all storage functions satisfying $V_i(0) = 0$ are Lyapunov stable and that the feedback interconnection of two passive systems is again passive.

Of the formulations covered, this one is the most comprehensive. It includes a new definition of PSS and shows stability of the system and the negative feedback interconnection of two systems. However, the proof that passivity is preserved when two systems are connected in feedback is omitted. With more work with this definition, this could be shown to be the most general definition of PSS.

Other than the technical assumptions, all three formulations share one of two main conditions in the definition of PSS. This assumption is that each active subsystem must be passive. The main differences between the definitions are in the form that the second condition takes. This condition is how the energy accumulated while inactive is bounded at switching instances. The first formulation provides a bound on the energy that is not tight. It reduces to a statement that all subsystems must be, on average, passive when the subsystems are inactive. The second formulation provides a much tighter bound on this energy. However, the definition is far from intuitive and appears to be very difficult to apply. The third formulation keeps a tight bound on the energy and does so without sacrificing the intuition and applicability of passivity. The definition statement based on passive and dissipative theory is clear, and examples were provided of simple systems have clear energy supply rates to meet the definition.

Appendix C - Interconnection Proofs

This appendix will provide theorems and proofs that show that passivity is a property that is preserved when two systems are interconnected in feedback or in parallel. This is the case when the two systems in the interconnection are both passive and not just that the passivity indexes exist. For both interconnections the result is intuitive since the energy stored in the interconnection is simply the sum of the energies stored in each of the systems. These are powerful results since they allow for the design of large scale stable systems by ensuring that each component of the system is passive and that these simple interconnection rules are satisfied. The first interconnection to consider is the negative feedback interconnection of two passive systems.

Theorem C-1. *The negative feedback interconnection (Fig. C-1) of two passive systems is passive.*

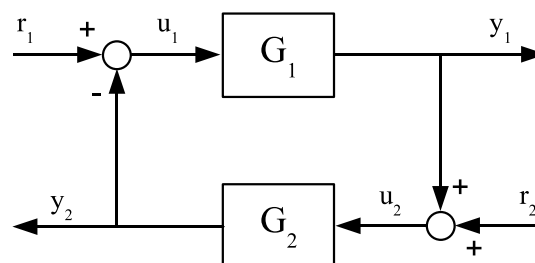

Figure C-1: The feedback interconnection of two passive systems.

Proof. The interconnection has the following loop relations.

$$\begin{aligned} u_1 &= r_1 - y_2 \quad \text{and} \\ u_2 &= r_2 + y_1. \end{aligned} \tag{C-1}$$

Each system being passive implies that there exist storage functions V_1 and V_2 such that

$$\begin{aligned} \int_{t_1}^{t_2} u_1^T(t)y_1(t)dt &\geq V_1(x_1(t_2)) - V_1(x_1(t_1)) \quad \text{and} \\ \int_{t_1}^{t_2} u_2^T(t)y_2(t)dt &\geq V_2(x_2(t_2)) - V_2(x_2(t_1)). \end{aligned} \tag{C-2}$$

Define a new storage function for the interconnection,

$$V(x) = V_1(x_1) + V_2(x_2). \tag{C-3}$$

Now sum the two passive inequalities above to show that the interconnected system is passive:

$$\begin{aligned} \int_{t_1}^{t_2} u_1^T y_1 dt + \int_{t_1}^{t_2} u_2^T y_2 dt &\geq V_1(x_1(t_2)) - V_1(x_1(t_1)) + V_2(x_2(t_2)) - V_2(x_2(t_1)) \\ \int_{t_1}^{t_2} [(r_1 - y_2)^T y_1 + (r_2 + y_1)^T y_2] dt &\geq V(x(t_2)) - V(x(t_1)) \\ \int_{t_1}^{t_2} r^T y dt &\geq V(x(t_2)) - V(x(t_1)). \end{aligned}$$

This shows that the mapping from r to y is passive so the interconnection is passive. \square

The next interconnection to consider is the parallel interconnection of two passive systems (Fig. C-2).

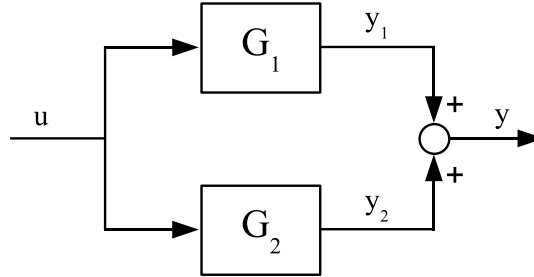

Figure C-2: The parallel interconnection of two passive systems.

Theorem C-2. *The parallel interconnection of two passive system is passive.*

Proof. Note that the system outputs satisfy the following relation $y = y_1 + y_2$. Each system being passive implies that there exist storage functions V_1 and V_2 to satisfy (C-2), where $u = u_1 = u_2$. The interconnected system has the same storage function (C-3). Now sum the two passive inequalities

above to show that the interconnected system is passive:

$$\begin{aligned} \int_{t_1}^{t_2} u^T y_1 dt + \int_{t_1}^{t_2} u^T y_2 dt &\geq V_1(x_1(t_2)) - V_1(x_1(t_1)) + V_2(x_2(t_2)) - V_2(x_2(t_1)) \\ \int_{t_1}^{t_2} [u^T y_1 + u^T y_2] dt &\geq V(x(t_2)) - V(x(t_1)) \\ \int_{t_1}^{t_2} u^T y dt &\geq V(x(t_2)) - V(x(t_1)). \end{aligned}$$

This shows that the mapping from u to y is passive so the interconnection is passive. \square

These two theorems are valid when combining passive systems. Systems are passive when both passivity indexes are positive. These theorems do not apply if either system has either index negative. The more general design cases where the indexes are allowed to be negative are covered in the control design section of this paper. In these cases, a feedback interconnection may still be passive even if one or both systems are not passive, assuming that the indexes exist for all subsystems of a switched system. The passivity index does not provide additional stability results when combining systems in parallel. In fact, if either system in the parallel interconnection is unstable, the connection is unstable.