

The Galactic Exoplanet Survey Telescope (**GEST**): A Search for Extra-Solar Planets via Gravitational Microlensing and Transits

D. P. Bennett [**PI**] (Notre Dame), C. Alcock (Penn), E. Cheng (Goddard), M. Clampin (STScI), J. Connor (Alaska), A. J. Drake (LLNL), P. Garnavich (Notre Dame), A. Gould (Ohio State), D. C. Jewitt, N. Kaiser (Hawaii), T. R. Lauer (NOAO), J. Lunine (Arizona), G. Luppino (Hawaii), D. Minniti (P. Universidad Catolica), S. J. Peale (UCSB), S. H. Rhie (Notre Dame), A. Stebbins (FNAL), R. L. Stevenson (Notre Dame), C. Stoughton (FNAL), C. Stubbs (Washington), D. Tenerelli (LMSS), D. Tytler (UCSD), N. J. Woolf (Arizona)

Abstract: GEST is a comprehensive extra-solar planet search mission sensitive to planets with masses as low as that of Mars. GEST employs a ~1.5m telescope with a 2 square degree field of view to monitor the Galactic bulge for 8 months per year for 3-4 years to detect planets via gravitational microlensing and transits. GEST 's microlensing survey will detect low-mass planets via high signal-to-noise variations of gravitational microlensing light curves. GEST will be able to measure the abundance of extra-solar planets as a function of planet:star mass ratio and separation, and for ~45% of detected events, follow-up observations with ground based AO systems will allow the determination of the stellar type for the planetary host stars. The planetary discoveries will not require follow-up observations to confirm the planetary interpretation, follow-up observations will be able to determine the stellar type of 45% of the stars which host planets. GEST will be able to detect ~100 Earth-mass planets at 1 AU (assuming ~1 such planet per star), and . GEST is sensitive to the microlensing signal of planets for planetary separations from ~0.7AU to infinity because GEST is able to detect the microlensing signature of free-floating planets. GEST will also be sensitive to giant planets at separations of 0-20 AU via transits of the Galactic bulge source stars. The transit survey should detect ~50,000 “hot Jupiters” if their abundance in the bulge is similar to the local abundance. During the 4 months per year when the Galactic bulge is not observable, GEST will do a deep, wide field survey to study the structure of the Universe via weak lensing and high redshift supernovae and to discover ~100,000 new KBOs. The GEST mission can be accomplished at low risk with established technology at a cost that is within the cost cap of NASA’s MIDEX and Discovery Programs.



The poster features a central illustration of the GEST satellite in space, with its large telescope aperture open. The satellite is shown against a backdrop of a colorful, star-filled galaxy. The title 'GEST' is prominently displayed in large, golden, 3D letters at the top, with the full name 'GALACTIC EXOPLANET SURVEY TELESCOPE' written in smaller white letters below it. The text 'Discovery Proposal' is centered at the bottom of the main image area. The bottom section of the poster is a dark purple band containing the logos of the participating organizations: NASA, Lockheed Martin, University of Notre Dame, University of Hawaii, Lawrence Livermore National Laboratory, and the Space Telescope Science Institute. A note at the bottom right states 'Operated for NASA by AURA'.

Discovery Proposal

NASA **LOCKHEED MARTIN** **UNIVERSITY OF NOTRE DAME**

University of Hawaii **Lawrence Livermore National Laboratory** **SPACE TELESCOPE SCIENCE INSTITUTE**

Operated for NASA by AURA

GEST's Primary Planet Detection Method

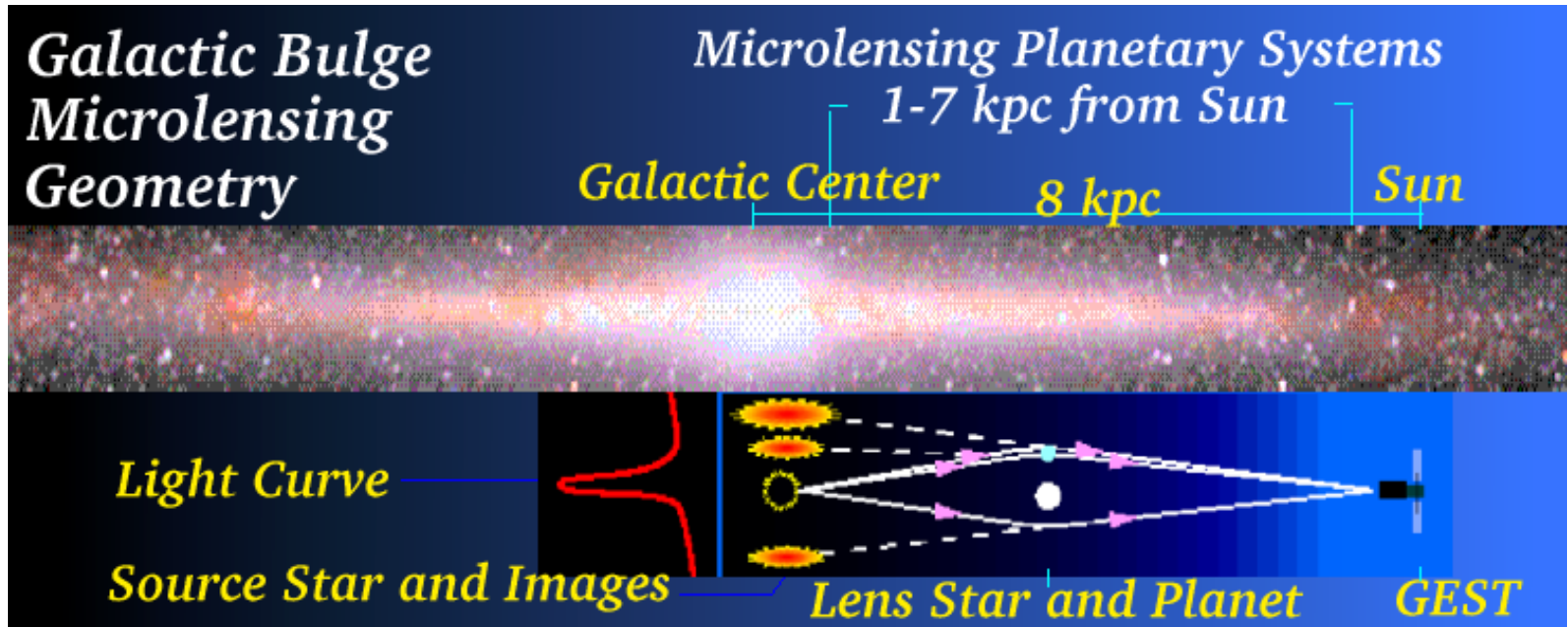

GEST observes $\sim 10^8$ Galactic bulge main sequence stars in order to study the planetary systems of foreground stars via gravitational microlensing.

The GEST Field

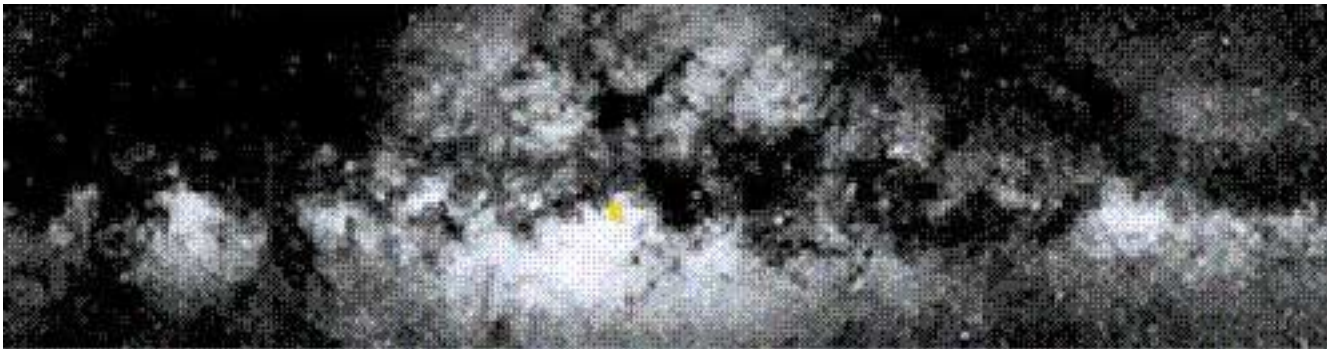

GEST will observe a field of 2 square degrees located $\sim 2.5^\circ$ from the Galactic center in a region of low extinction.

The **GEST** Mission

- 1.5m telescope with ~ 2 sq. deg. FOV
- polar orbit: 1000-1500 km altitude.
- continuous view of Galactic bulge
 - a single field is observed for 8 months per year
- LM-900 Spacecraft
 - pointing stability: better than $0.021''$ except for a few minutes per day when angular momentum is dumped
- Data is down-linked once per orbit
 - ground station at U of Alaska, Fairbanks, SAR Facility
 - 11m dish, with 10m as backup.
 - 16 Mb per sec, for 10 minutes per orbit
- 4 months per year, non-bulge season
 - weak lensing and high-z SN search
 - ~ 1 months per year: Kuiper Belt Object (KBO) Search
 - 100,000 new KBOs discovered
 - Participating Scientist Program
 - observers propose to NASA for observing time

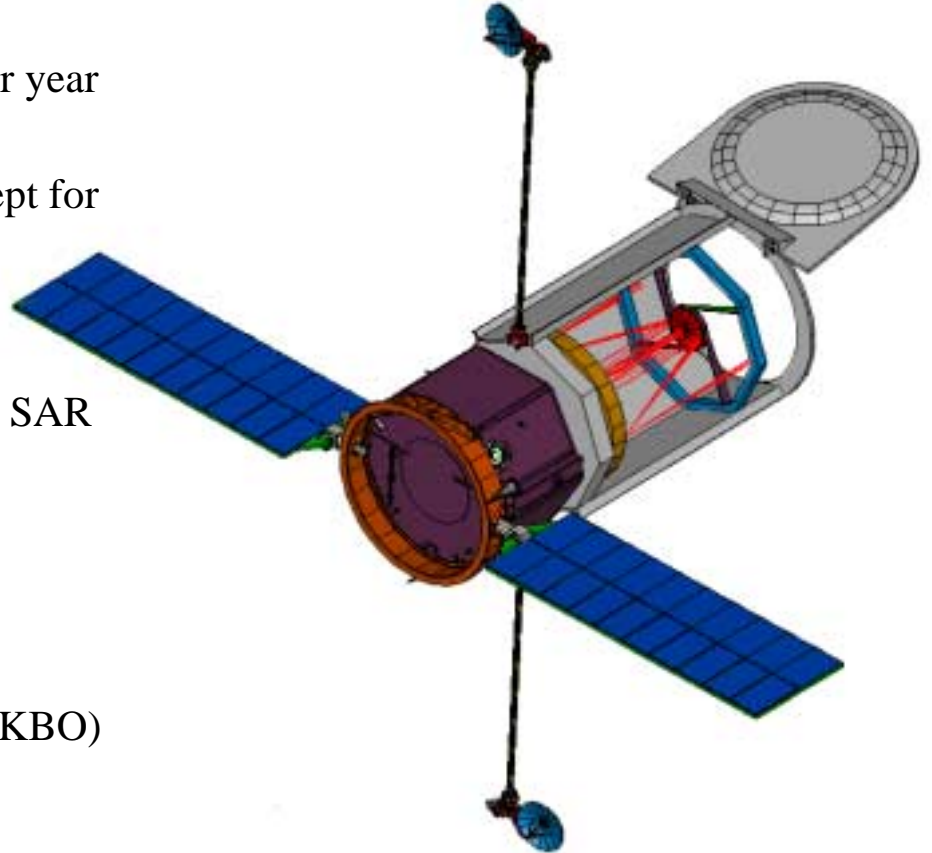

GEST Optics

08:40:28

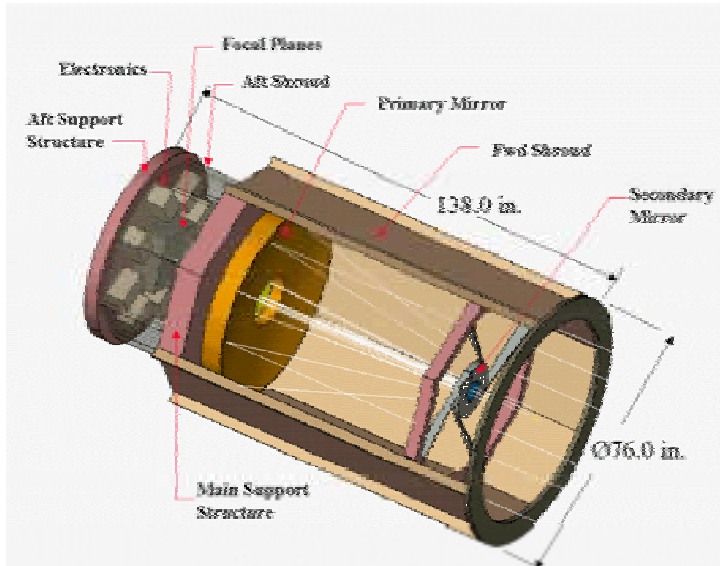

Previously proposed design:
field widened Cassegrain

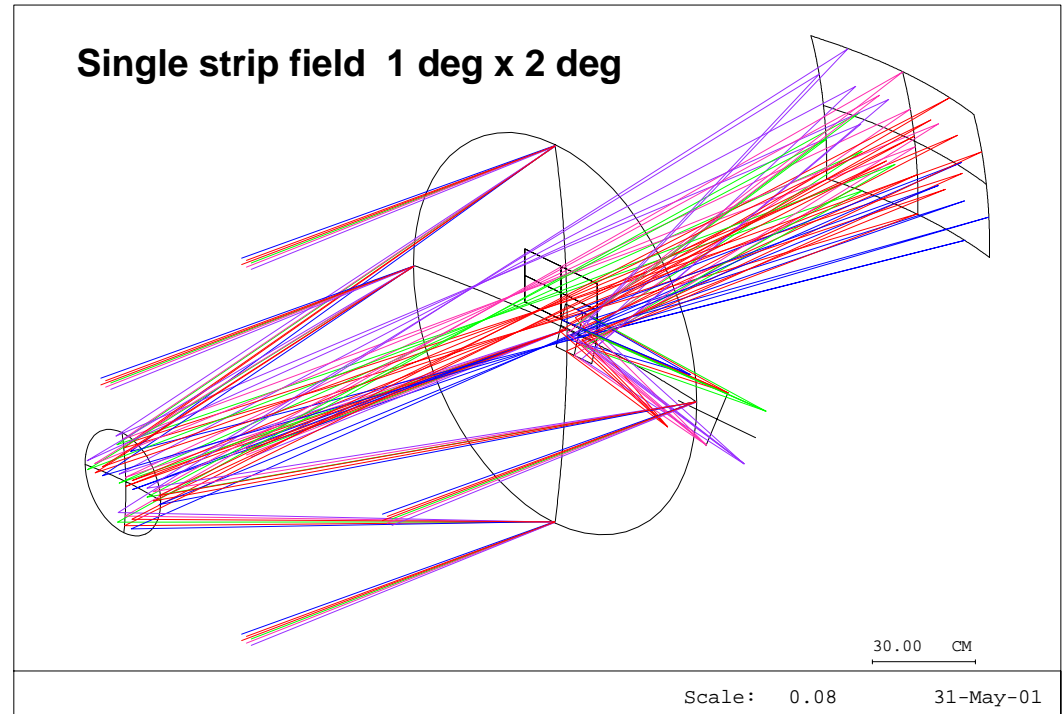

Under Study: Offset 3 Mirror Anastigmatic Design

- allows filter wheel, simple shutter
- non-circular field => more events!
- better baffling

GEST Instrument

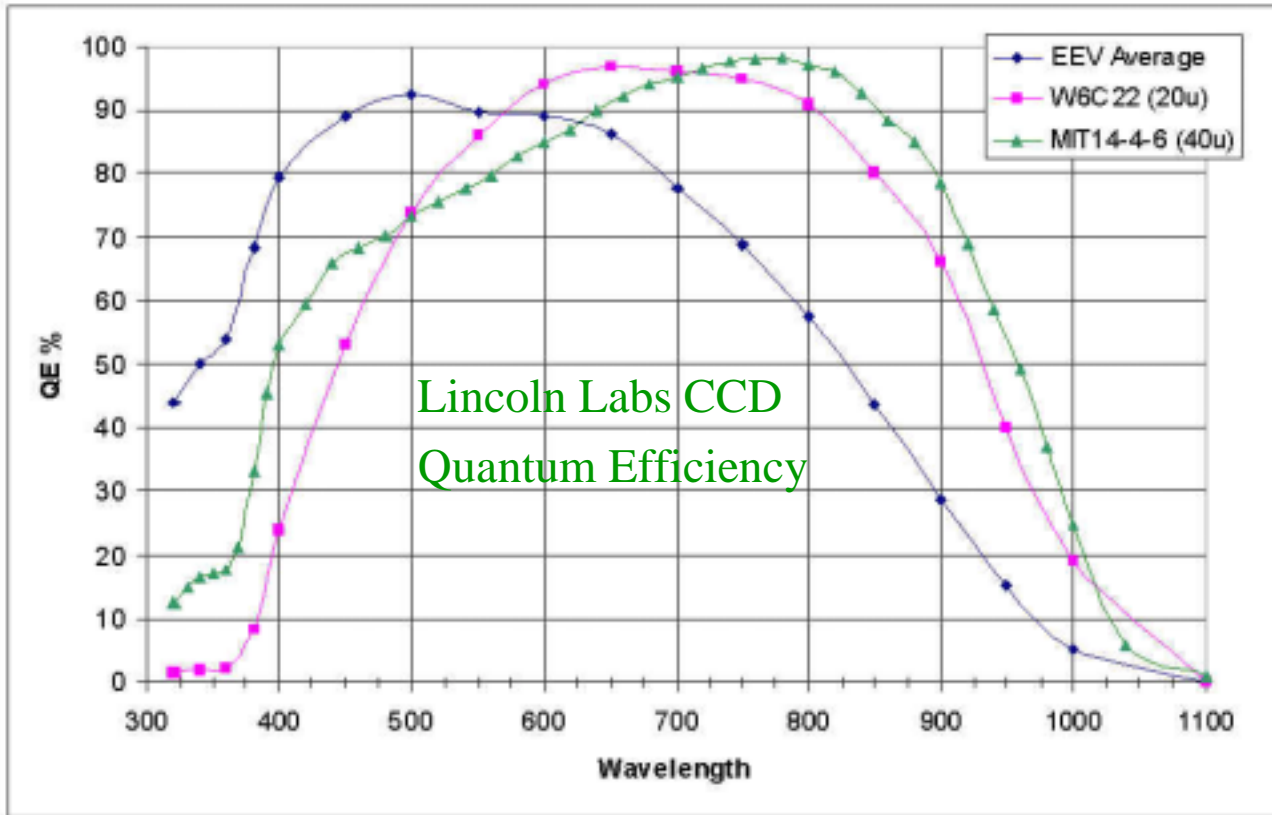

- diffraction limited optics at $\sim 0.9\mu\text{m}$
- 2×1 degree focal plane
- 36 $3\text{k} \times 6\text{k}$ Lincoln Labs CCDs
 - near-IR optimized high resistively devices (in green)
 - 40% better sensitivity than standard CCDs

GEST Data Processing

- Images taken every 2 min.
 - co-added, removing cosmic rays, to make 10-min exposures
- All data sent to ground station at U of Alaska, Fairbanks
- Real time data reduction at UAF
- Crowded fields with undersampled images
 - sampling similar to Hubble's WFPC2 V-band images
 - continuous observations allow dithering on a sub-pixel grid
 - photometric accuracy determined by photon statistics
 - (Lauer 1999, Gilliland et al 2000)
 - include excess photons from the lens star and neighbors

GEST Simulation

- Continuous observations of 2 sq. deg. central Galactic bulge field
- HST luminosity function from Holtzman et al (1998)
- mass function from Kroupa (2000), Zoccali et al (2000)
- ~10,000 events in 3 seasons
- microlensing probability, $\tau = 3.4 \times 10^{-6}$, assumed
 - at Galactic coordinates: $l = 1.3^\circ$, $b = -2.4^\circ$
 - $\sim 1.6\sigma$ lower limit on measured value

Simulated Planetary Light Curves from GEST

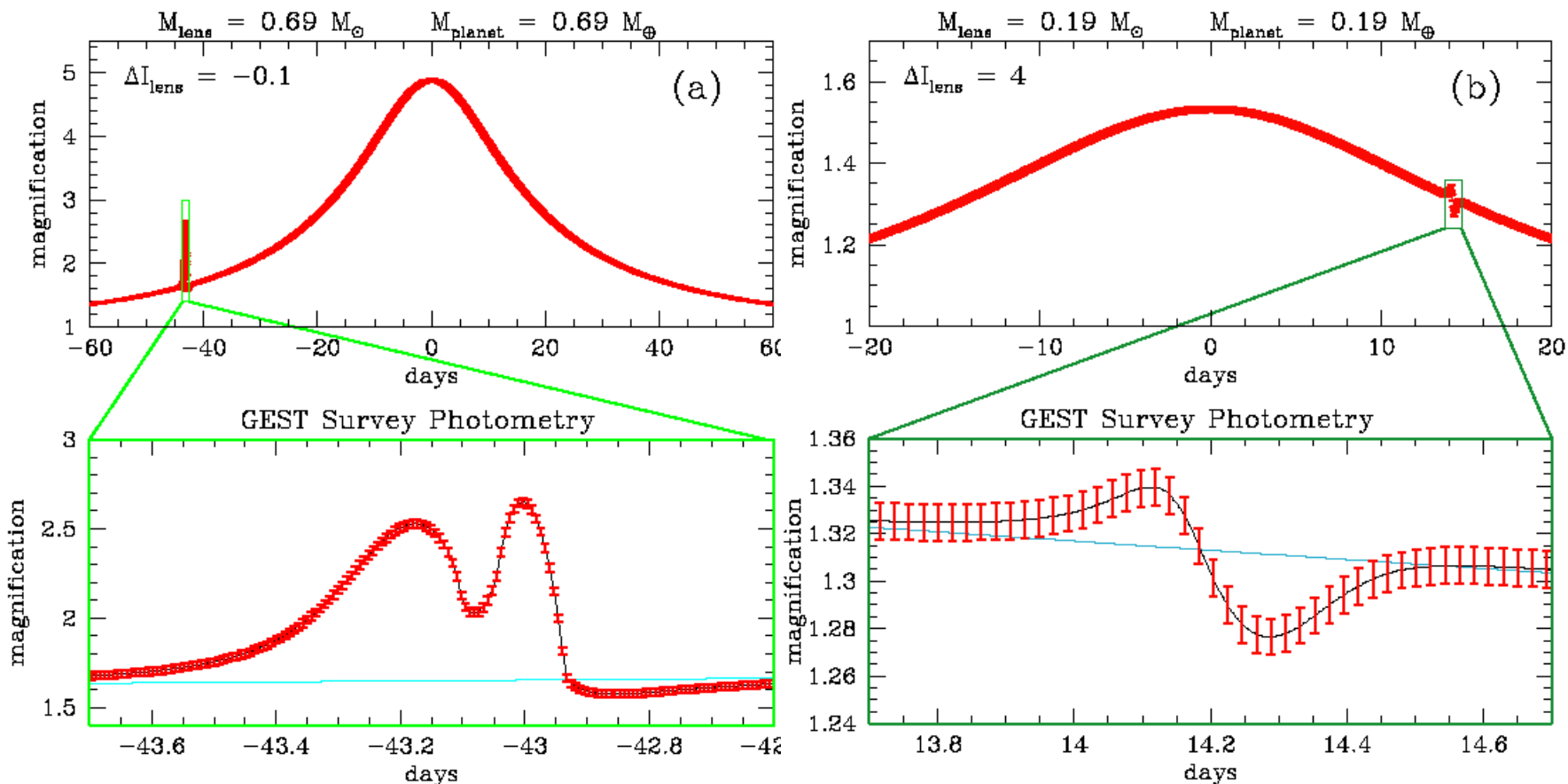

Example light curves are shown above from a simulation of the GEST mission. In each case, the top panel shows the full light curve, and the planetary deviation region(s), outlined in green, is blown up and shown in the lower panel. All of the example light curves have the Earth:Sun mass ratio of $\epsilon = 3 \times 10^{-6}$. Our planetary detection significance parameter is $\Delta\chi^2$, which is the difference between the χ^2 values for single-stellar lens and star+planet lens system fits. (a) and (b) span the range of planetary detection significance from $\Delta\chi^2 = 60,000$ (a) to $\Delta\chi^2 = 180$ (b) which is just above our cut.

Simulated Planetary Light Curves from **GEST** (cont.)

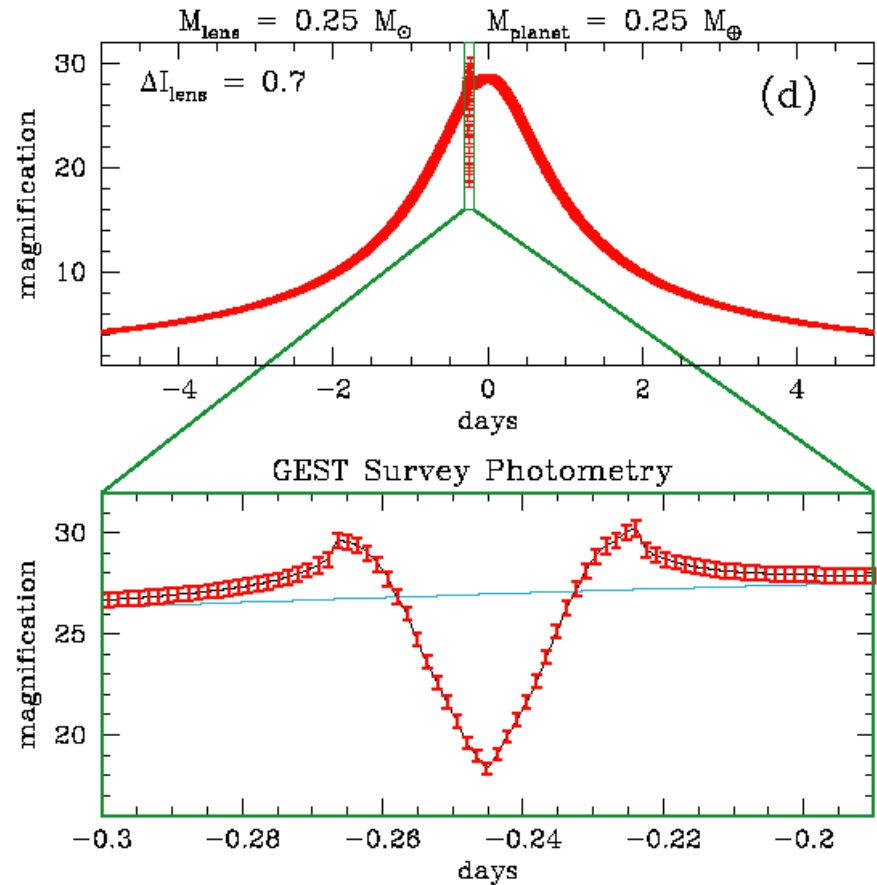
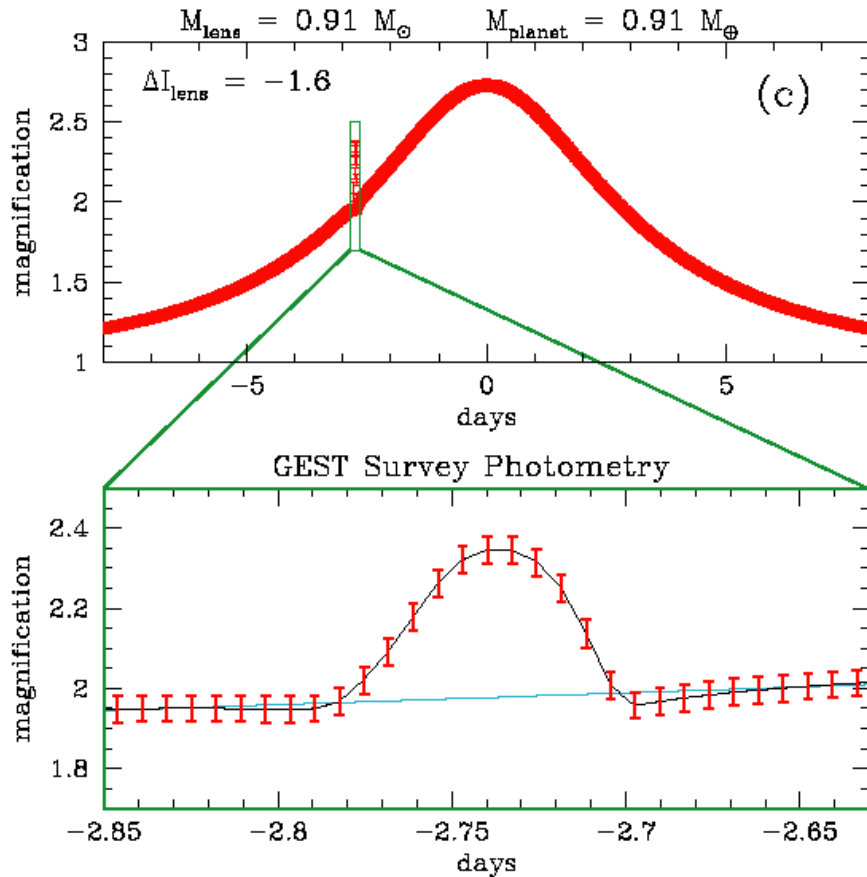

(c) and (d) show more typical light curves with $\Delta\chi^2 = 600\text{-}1300$. The planets detected in (b) and (c) have orbital radii of 1 AU while the events shown in (a) and (d) have orbital radii of 5 and 2.5 AU, respectively. ΔI_{lens} is the difference between lens and source I magnitude.

GEST's Double Planet Detections

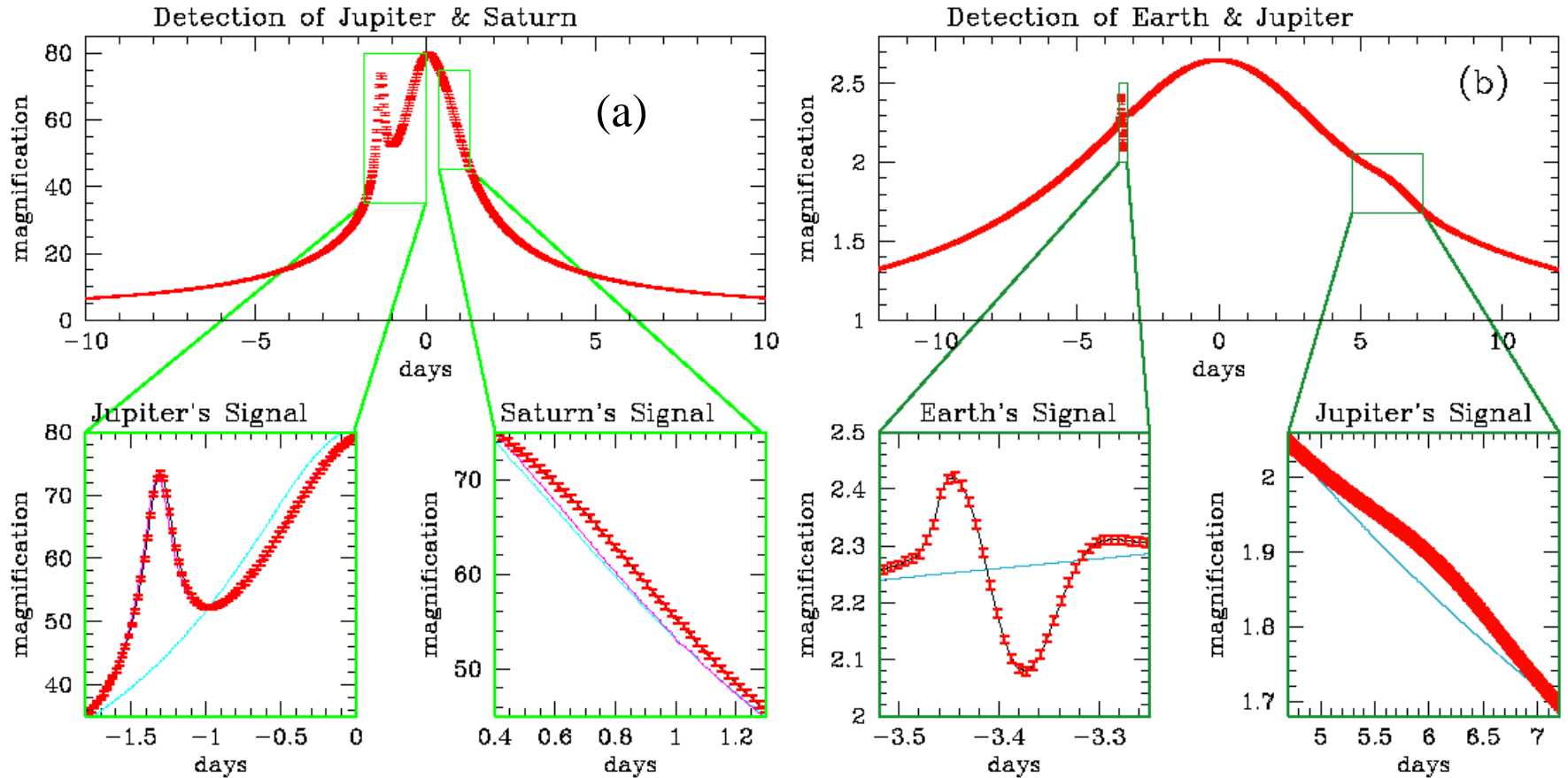

Above are example multiple planet light curves from our simulation of planetary systems with the same planetary mass ratios and separations as in our solar system. (a) is an example of a Jupiter/Saturn detections (with $\epsilon = 10^{-3}, 3 \times 10^{-4}$; $a = 5.2, 9.5$) and (b) is an example of the detection of Earth and a Jupiter (with $\epsilon = 3 \times 10^{-6}, 10^{-3}$; $a = 1, 5.2$ AU). We expect ~ 60 examples of Jupiter+Saturn and ~ 10 examples of Jupiter+Earth (or Venus or Mars) if each star has such a system.

Detection of a Planet and Its Moon

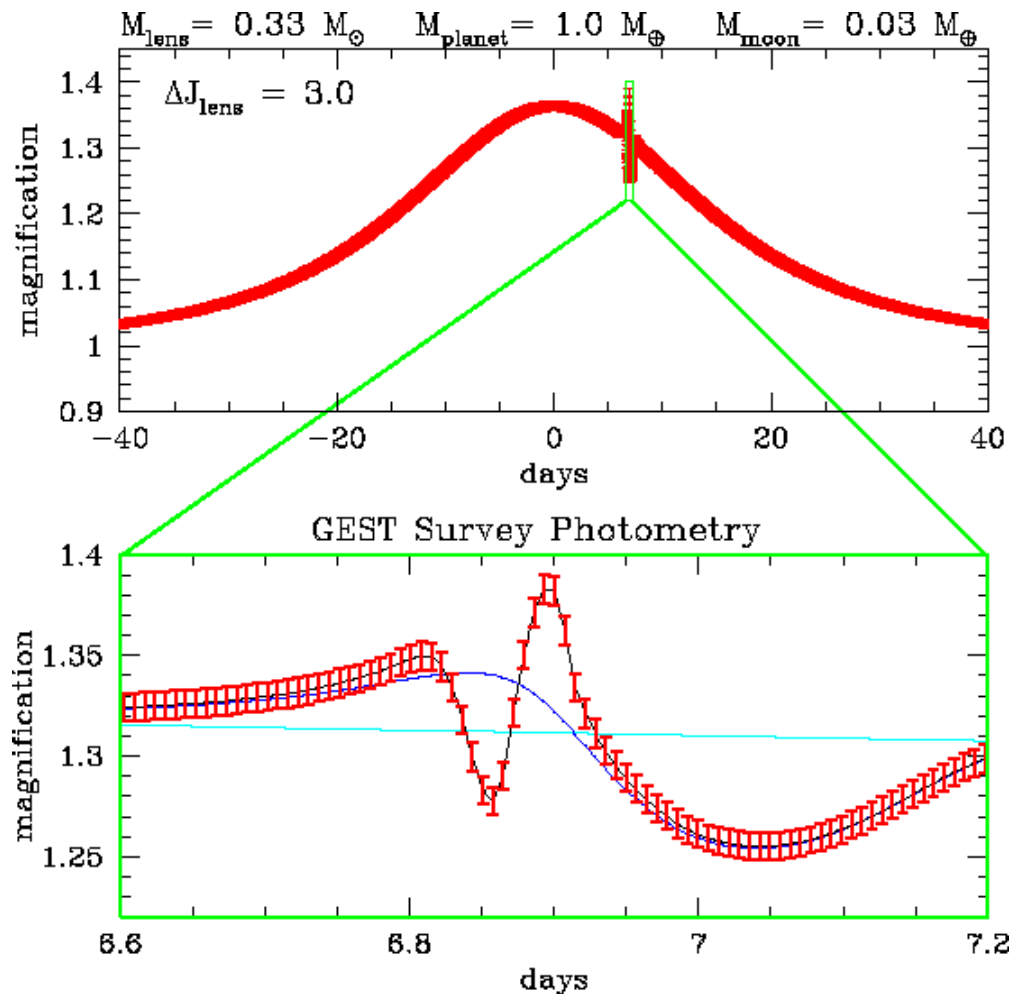

This is an example of a light curve which indicates the presence of a large moon orbiting the detected planet. The blue curve indicates the expected light curve with no moon. In this case, an Earth mass planet orbits an M-dwarf with a moon of 2.5 Lunar masses orbiting at about twice the distance of the Earth's moon. Such large moons are thought to aid in the development of animal life on the planet.

GEST's Planetary Detection Sensitivity

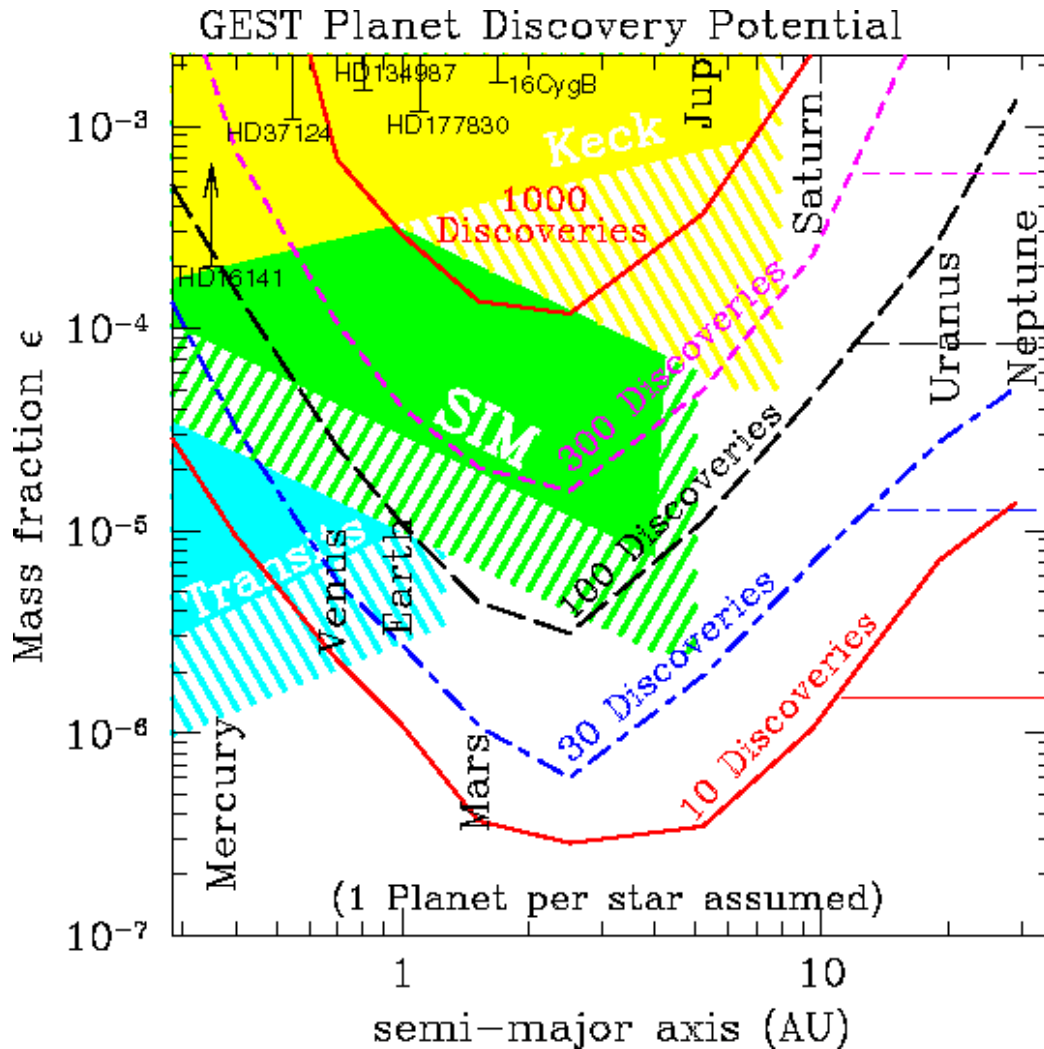

The GEST mission sensitivity is plotted above as a function of planetary mass fraction, ϵ , and separation. The different curves indicated the effective number of planetary systems surveyed at the different sensitivity levels. At least 10 systems are surveyed for planetary systems with parameters above the red lines, and more than 100 systems are surveyed above the black line. The solid yellow region can be searched for planets with a 20-year radial velocity program on the Keck assuming a detection threshold of 10 m/sec, and the yellow lines indicate the sensitivity of a 10-year Keck interferometric astrometry program with a $30\mu\text{as}$ detection threshold. The green regions indicate the sensitivity of the SIM recommended and floor missions while the cyan regions indicate the sensitivity of space-based transit surveys such as COROT, Eddington and Kepler. The location of our Solar System's planets are indicated, as are a number of the detected extra-solar planetary systems. Most detected Earth mass planets have $\epsilon \approx 10^{-5}$ because the typical lens star has a mass of $\sim 0.3 M_{\odot}$, so the plot suggests that GEST can see ~ 35 Earth-mass ratio planets at 1 AU and ~ 100 Earth-mass planets at that distance. The horizontal lines indicate the sensitivity to free-floating planets since the more distant planets can sometimes be detected without seeing a microlensing signal from their star. The detection threshold used is a $\Delta\chi^2 \geq 160$ improvement with a planetary light curve fit vs. a single lens light curve fit. This is equivalent to a 12.5σ threshold.

GEST's Free Floating Planetary Detection Sensitivity

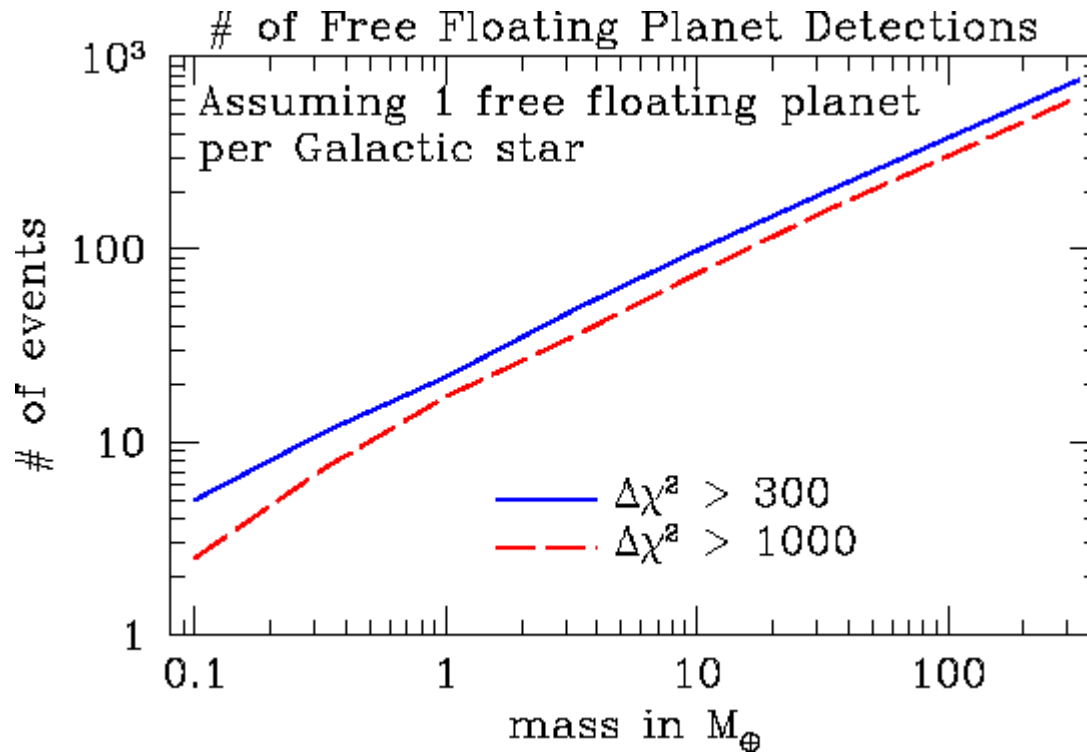

The number of free-floating planets to be discovered by GEST are plotted above vs.~planetary mass for 2 different detection criteria which are equivalent to 17σ and 30σ , respectively. It is thought that many low-mass planets may be ejected from planetary systems via gravitational interactions during the planetary formation process, so we expect to detect a large number of planets in the terrestrial mass range.

Bright Lenses

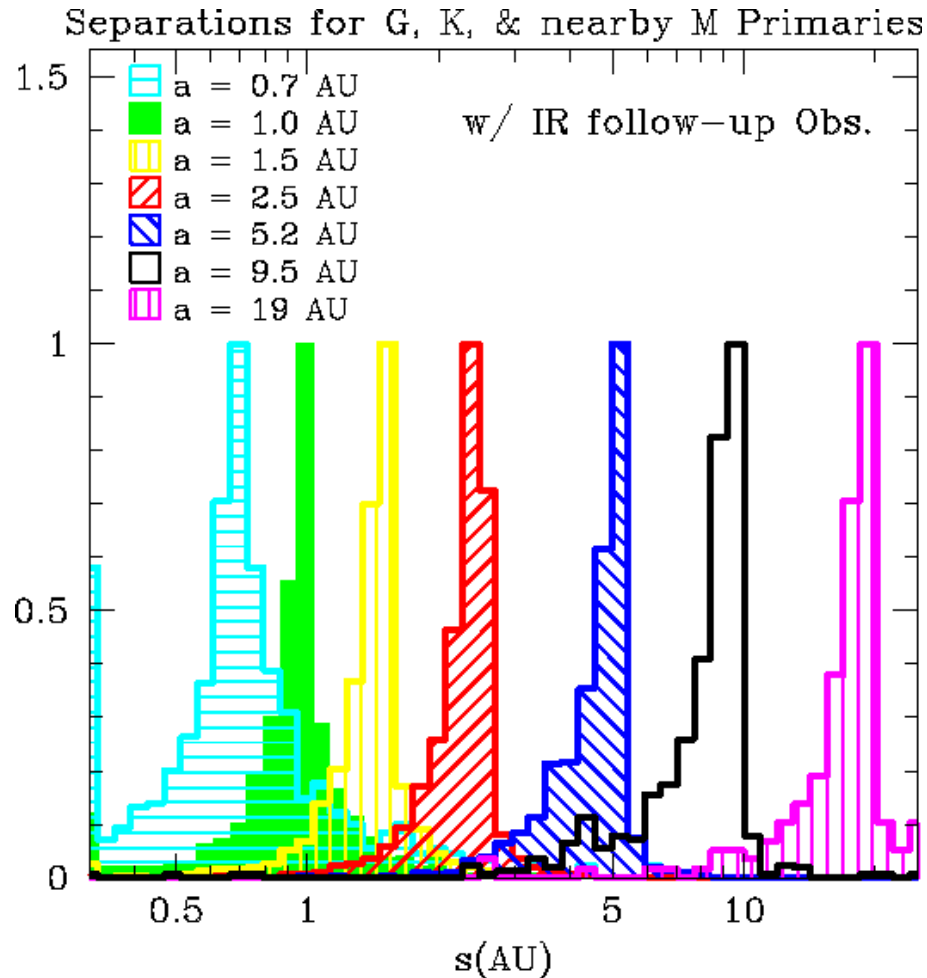

For ~45% of the lens stars which the detected planets orbit, the lens is >10% of the brightness of the source star. In these cases, which include nearly all of the G and K star lenses, it is possible to determine the spectral type of the lens star. This allows a determination of the star-planet separation in physical units. The figure above shows the estimated projected separations for planets with different 3-dimensional separations.

Planetary Transits from GEST

- $\sim 10^8$ stars surveyed with $0.3R_{\odot} \leq R \leq R_{\odot}$
- Sensitive to planets down to R_{saturn}
 - in 5 hours: 6.5σ at R_{saturn} , 9σ at of R_{Jupiter}
- 50,000 “Hot Jupiter” detections
 - assuming 1% abundance
- If each star has a planet, then geometric and timing constraints allow:

Semi-major Axis (AU)	Period (yrs.)	# of detections (with 1 planet per star)	# of transits per planet & transit duration (hrs.)
0.04	~ 0.01	5,000,000	$\sim 200 \times 2.5$
0.4	~ 0.3	600,000	$\sim 7 \times 8$
1.0	~ 1.3	160,000	$\sim 2 \times 13$
5.2	~ 15	6,000	$\sim 1 \times 30$
9.5	~ 40	1,300	$\sim 1 \times 40$
19.0	~ 110	200	$\sim 1 \times 60$

GEST Summary & Expected Results

- **GEST** will satisfy the McKee-Taylor Committee's prerequisite for TPF:
 - “space- and ground-based searches will confirm the expectation that terrestrial planets are common”
- Low mass planets detected via microlensing
 - high signal-to-noise detections => robust method
 - ~100 Earth-mass planets: **1st detection of Earths**
 - some sensitivity down to M_{mars}
 - sensitivity from 0.7AU-infinity
- Giant planets detected via Microlensing and transits
 - sensitivity from 0-infinity
- Low Risk Mission
 - no astronomical background
 - All technology in hand
- Planets detected rapidly via microlensing - even in ~20 year orbits
- Expected Exoplanet Results:
 - mass fraction ($\epsilon = M_{\text{planet}}/M_*$) and separation (to a factor of ~2) always measured
 - AO follow-up observations identify lens star for G, K, and early M stars (~45% of all events)
 - average number of planets per star down to M_{Mars}
 - planetary mass function, $f(\epsilon = M_{\text{planet}}/M_*)$; as a function of M_* for $0.3M_{\odot} \leq M_* \leq 1 M_{\odot}$.
 - abundance of free-floating planets down to M_{mars}
 - the ratio of free-floating planets to bound planets.
 - Abundance of planet pairs
 - high fraction of pairs => near circular orbits