

# Design of a Porous Electroosmotic Pump Used in Power Electronic Cooling

Youcef Berrouche, Yvan Avenas, Christian Schaeffer, Hsueh-Chia Chang, and Ping Wang

**Abstract**—In power electronic liquid cooling systems, the hydraulic circuit is generally implemented by a mechanical pump, which is big, noisy, expensive, and has a high power consumption. To solve these problems, it is proposed to replace the mechanical pump by an electrokinetic one, such as an electroosmotic (EO) pump. In this paper, we present the theory of electroosmosis phenomena and the model and design of a porous EO pump (PEOP). The PEOP is fabricated on the base of two types of porous ceramics (sintered alumina and silica). Using deionized water as pumping liquid and silica, the PEOP generates 13.6 mL/min and 2 kPa at 150-V applied voltage. The power consumed by the pump is less than 0.4 W. The PEOP works without any bubbles in the hydraulic circuit. This pump can be used to cool 22.6 W of power generated by the power components with a forced convection without evaporation and 270 W with evaporation. A test experiment with alumina shows a good accordance in terms of pressure and flow rate with the PEOP model.

**Index Terms**—Electrokinetic (EK), electroosmosis, experiment, forced convection, passive electronic cooling, porous medium.

## I. INTRODUCTION

SINCE THE appearance of the insulated gate bipolar transistors, working with high switching frequencies while having large values of current and voltage, the heat-flux density generated by the electronic components became more and more important. Nowadays, thermal management is a critical aspect in power electronic system conception. In this context, consideration is given to various technologies developed to meet the difficult cooling requirements of high-density power electronic equipment for the industry such as forced convection liquid cooling, heat pipes, loop heat pipes, pulsating heat pipes, Peltier cooling plates, etc.

All these technologies have pros and cons. For example, cooling by heat pipes is really advantageous because of the au-

Paper IPCSD-09-011, presented at the 2007 Industry Applications Society Annual Meeting, New Orleans, LA, September 23–27, and approved for publication in the IEEE TRANSACTIONS ON INDUSTRY APPLICATIONS by the Power Electronics Devices and Components Committee of the IEEE Industry Applications Society. Manuscript submitted for review October 10, 2007 and released for publication May 6, 2009. First published September 18, 2009; current version published November 18, 2009.

Y. Berrouche was with the Grenoble Electrical Engineering Laboratory (G2Elab), Grenoble Institute of Technology, 38402 Saint Martin d'Herès Cedex, France. He is now with Concordia University, Montreal, QC H3G 1M8, Canada.

Y. Avenas, and C. Schaeffer are with the Grenoble Electrical Engineering Laboratory (G2Elab), Grenoble Institute of Technology, 38402 Saint Martin d'Herès Cedex, France (e-mail: Yvan.Avenas@g2elab.grenoble-inp.fr).

H.-C. Chang and P. Wang are with the Department of Chemical and Biomolecular Engineering, University of Notre Dame, Notre Dame, IN 46556-5637 USA (e-mail: hchang@nd.edu).

Color versions of one or more of the figures in this paper are available online at <http://ieeexplore.ieee.org>.

Digital Object Identifier 10.1109/TIA.2009.2031934

tonomous circulation of the cooling fluid. However, they cannot work against gravity if the distance between the heat and the cold sources is higher than 1 m. Pulsating heat pipes and loop heat pipes can provide solutions for these problems but they cannot cool heat-flux densities higher than 200 W/cm<sup>2</sup>.<sup>1</sup> For power electronic cooling with high heat flux and heat transfers on large distances, the forced convection liquid cooling remains the best solution. This cooling method can be with or without evaporation of the cooling fluid [1]. The motion of this fluid is usually ensured by a mechanical pump. The main disadvantages of using mechanical pumps are that they are big, noisy, and expensive. Electrokinetic (EK) pumps do not suffer from these disadvantages and can perhaps be used to replace the mechanical ones in forced convection electronic cooling systems. In this paper, we focus on the use of one of the most popular EK pumps: the electroosmotic (EO) pump.

Various EO pumps have been developed. Proetorius *et al.* [2] and Theeuwes [3] first proposed this concept for high-speed liquid chromatography. Paul *et al.* [4] reported that a capillary EO pump packed with silica microparticles can produce a pressure of 10 atm and a flow rate of 0.03  $\mu$ L/min at 1.5-kV applied voltage. The high pressure is produced by the small pores of the packing-hydrodynamic resistance. In their work, authors showed the advantage of using a porous media in order to increase the pressure generated by the EO pumps. This pump is called porous EO pump (PEOP). Zeng *et al.* [5], [6] employed two polymer frits to sandwich a layer of densely packed silica microparticles in a cube-shaped acrylic frame (transverse dimension 15 mm) which can provide flow rates as high as 0.8 mL/min with 1-atm backpressure. Goodson *et al.* [7] have developed a high-flow-rate EO pump based on porous silica that generates up to 20 mL/min. This PEOP has been realized to cool a laptop by Cooligy Company and the University of Stanford. The pumping fluid was buffered deionized (DI) water (Na<sub>2</sub>B<sub>4</sub>O<sub>7</sub> dissolved into 1 L of DI water), and the porous media was made with sintered silica.

In this paper, after having recalled the theory of electroosmosis pumping, we present a classical model of PEOP. Then, we present a simplified estimation of the minimal flow rate required to cool an electronic component dissipating more than 100 W. In this context, we show that power electronic cooling needs to work with convective boiling. Thus, a pure liquid like DI water is necessary. Finally, we present our first prototype, the experimental results, and their comparison with the model. This prototype works with DI water and with a porous sintered alumina (or silica) disk.

<sup>1</sup>[www.thermacore.com](http://www.thermacore.com)

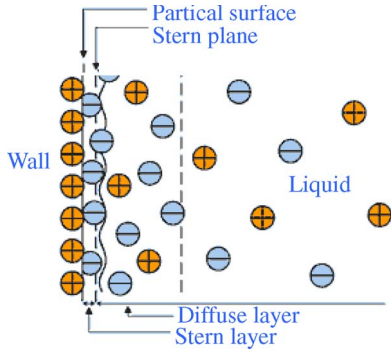

Fig. 1. Structure of the EDL.

II. THEORY OF ELECTROOSMOSIS PUMPING

The basis of EO pumps is the formation and manipulation of electric double layers (EDLs) (Fig. 1). If we consider that a liquid is in contact with a wall (electrical insulator as a ceramic), the wall will be charged positively or negatively and will form the charged surface, which will attract the ions of the opposite charge in the liquid, the so-called counterions. Hence, an area will exist, where the concentration of counterions is larger than that of the coions. This phenomenon leads to the formation of an EDL or Debye layer. The remains of the liquid, which is called the bulk, stay neutral. The Debye layer is divided into two layers, the inner one (Stern layer), which is immobile due to strong electrical forces, and the outer one (the diffusive layer), which contains free charges. This layer has a length called Debye length  $\lambda$  which can be given by [8]

$$\lambda = \sqrt{\frac{\epsilon k_B T}{2e^2 \cdot z \cdot n}} \tag{1}$$

where  $\epsilon$ ,  $n$ ,  $k_B$ ,  $T$ ,  $e$ , and  $z$  are the dielectric permittivity of the liquid, the counterion concentration of bulk solution, the Boltzmann number, the temperature of the liquid, the electron charge, and the valance number of the counterions, respectively.

The Debye length can be controlled by adjusting the counterion concentration. This concentration can be modified by changing the conductivity of the liquid.

The electrical potential between these layers is called zeta potential  $\zeta$  which highly depends on the pH of the working fluid. The diffusive layer may be easily affected by an external tangential electric field. When that happens, ions in this layer suffer a Coulombic force and move toward the electrode of opposite polarity. This creates motion of the fluid near the wall and transfers momentum via viscous forces into the bulk (Fig. 2).

Rice and Whitehead [9] derived the velocity profile  $u(r)$  in a capillary of radius  $a$  under a tangential electrical field  $E$ , assuming that the pressure gradient was constant

$$u(r) = \frac{-a^2 \Delta P}{4\mu l_c} \left(1 - \frac{r^2}{a^2}\right) - \frac{\epsilon \zeta \cdot E}{\mu} \left(1 - \frac{\psi(r)}{\zeta}\right) \tag{2}$$

where  $\mu$ ,  $\zeta$ ,  $\Delta P$ , and  $l_c$  are the viscosity of the working fluid, the zeta potential, the pressure drop, and the length of the capillary, respectively.  $\psi(r)$  is the electrical potential in the capillary due to the EDL. It is called the inner potential. The velocity profile in a capillary of radius  $a$  for different

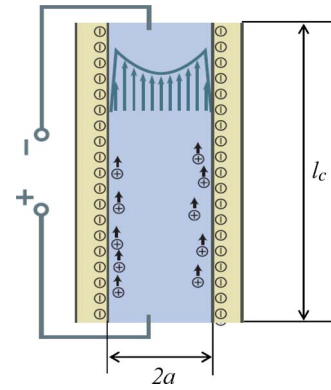

Fig. 2. EO pumping in a capillary.

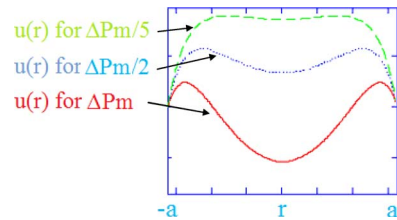

Fig. 3. Velocity profile  $u(r)$  in a capillary of radius  $a$  for different values of the pressure drop.

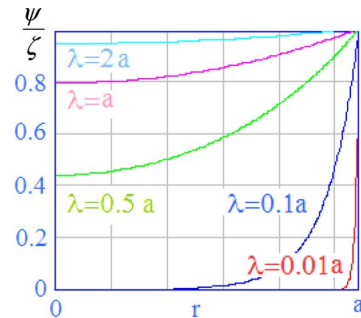

Fig. 4. Variation of the normalized inner potential profile for different values of the Debye length.

pressure drops is shown in Fig. 3. It can be seen that the velocity profile is highly influenced by the operating pressure.  $\Delta P_m$  represents the maximum pressure provided by the capillary pump (for this value, the average velocity on a section is zero).

In order to get a closed-form analytical solution of the profile of the inner potential across the capillary, the Debye–Huckel approximation can be used. This assumption gives

$$\psi(r) = \zeta \cdot \frac{I_0\left(\frac{r}{\lambda}\right)}{I_0\left(\frac{a}{\lambda}\right)} \tag{3}$$

where  $I_0$  is the zero-order modified Bessel function of the first kind.

The variation of the normalized inner potential profile  $(\psi(r)/\zeta)$  in a capillary of a radius  $a$  for various values of the Debye length is shown in Fig. 4. The very small value of the Debye length (in nanometers) gives a very low flow rate (several microliters per minute) [10], [11]. To increase the hydraulic power, we have to increase the surface contact between the wall and the liquid; hence, a porous structure can be used. To create this structure, it is possible to use a monolithic silica matrix,

which can be made from sol-gel. The mechanical resistance of the monolithic silica matrix is low; hence, it can be used only for small PEOPs [10] (diameter lower than 1 mm). The monolithic silica matrix can be easily prepared by referring to the procedures of [12]–[14]. Other authors like Zeng *et al.* [5] and Brask [8] have used sintered borosilicate disks that contain 80.60% silica (SiO<sub>2</sub>), 12.60% boric oxide (B<sub>2</sub>O<sub>3</sub>), and 4.20% sodium oxide (Na<sub>2</sub>O). These samples are fabricated by ROBU company (Germany).

The theoretical study of the electroosmosis in a porous structure is very complicated due to the complex geometry of the sintered silica. To simplify the study of a porous disk that has a cross-sectional area  $A$  and a length  $l$ , it can be considered like many parallel capillary pumps of effective radius  $a_{\text{eff}}$ . Zeng *et al.* [5] extended the maximum pressure  $\Delta P_m$  and the maximum flow rate  $Q_m$  for a PEOP as follows:

$$Q_m = \frac{\Psi \cdot A \cdot \zeta \varepsilon V}{\mu \cdot l \cdot \tau} \cdot \left[ 1 - \frac{2}{a_{\text{eff}}/\lambda} \frac{I_1(a_{\text{eff}}/\lambda)}{I_0(a_{\text{eff}}/\lambda)} \right] \quad (4)$$

$$\Delta P_m = \frac{8\zeta \varepsilon V}{a_{\text{eff}}^2} \cdot \left[ 1 - \frac{2}{a_{\text{eff}}/\lambda} \frac{I_1(a_{\text{eff}}/\lambda)}{I_0(a_{\text{eff}}/\lambda)} \right] \quad (5)$$

where  $\Psi$ ,  $\tau$ ,  $a_{\text{eff}}$ , and  $V$  are the porosity, the tortuosity, the effective pore size of the porous disk, and the applied voltage, respectively.  $I_0$  and  $I_1$  are the zero- and first-order modified Bessel functions of the first kind.

One of the most important parameters which characterizes an EO pump is the thermodynamic efficiency which is given by

$$\eta = \frac{Q \cdot \Delta P}{V \cdot I} \quad (6)$$

where  $Q$ ,  $\Delta P$ , and  $I$  are the operating flow rate, the operating pressure drop, and the current in the EO pump, respectively.

The thermodynamic efficiency represents the hydraulic power generated over the total electrical power consumed by the EO pump. It has been established by authors that the thermodynamic efficiency of the EO pumps is very low (less than 0.4%) [8], [10]. Hence, the optimization of the PEOP is required. Berrouche *et al.* [15] experimentally showed that the optimum thermodynamic efficiency was maximal for an effective pore radius that is four times higher than the Debye length.

In the next parts, we will show that a PEOP could be used in power electronic cooling. First, we will estimate the required flow rate, and then, we will present experimental results that are in accordance with these requirements.

### III. APPLICATION: ELECTRONIC COOLING

#### A. Principle of Forced Convection Liquid Cooling

The principle of the cooling by forced convection is shown in Fig. 5. This cooling system works when a coolant liquid flows in a closed loop. This motion is ensured by a pumping system (a PEOP in our case). In the power electronic device area, the generated heat is absorbed by the cooling fluid. When the fluid crosses the heat sink, the heat power will be dissipated in the ambient area. In case of forced convection with evaporation, the fluid becomes a vapor in the heat exchanger (evaporator), and

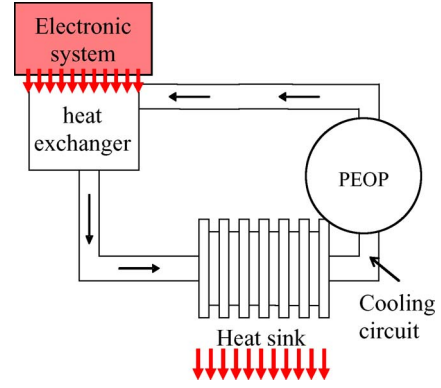

Fig. 5. Forced convection used in electronic cooling.

it returns back to a liquid in the heat sink (condenser). Usually, the minimal liquid flow rate is given by both the power losses and the heat-transfer coefficient in the heat exchanger. In order to give a simplified equation of this flow rate, we will only make an energy balance (the temperature drop between the electronic components and the fluid would not be taken into account because it depends on the heat-exchanger construction).

#### B. Minimal-Flow-Rate Calculation

In case of forced convection without evaporation, the heat dissipated by the electronic components is absorbed by the cooling fluid; hence, the power transmitted can be written as

$$P_E = \rho \cdot Q \cdot C \cdot \Delta T \quad (7)$$

with  $\rho$ ,  $C$ ,  $Q$ ,  $P_E$ , and  $\Delta T$  are the density, the specific heat capacity of the working fluid, the flow rate, the power generated by the electronic component, and the difference of the fluid temperature between the input and output of the heat exchanger, respectively.

Therefore, the flow rate will be given as

$$Q = \frac{P_E}{C \cdot \Delta T \cdot \rho} \quad (8)$$

In forced convection with evaporation, the minimal liquid flow rate depends also on the heat generated by the components. If all the liquid is evaporated, we can write

$$P_E = \rho \cdot Q \cdot L_v \quad (9)$$

Thus, the evaporated liquid flow rate is

$$Q = \frac{P_E}{L_v \cdot \rho} \quad (10)$$

where  $L_v$  is the latent heat of the working fluid.

For example, in order to cool a heat dissipation of 100 W with water, the pump must generate at least 30 and 2.5 mL/min for forced convection without and with evaporation, respectively.

#### C. Application of the PEOP in the Forced Convection

In order to cool a high heat-flux density in a small area, the heat exchanger must have a high heat-transfer coefficient. This

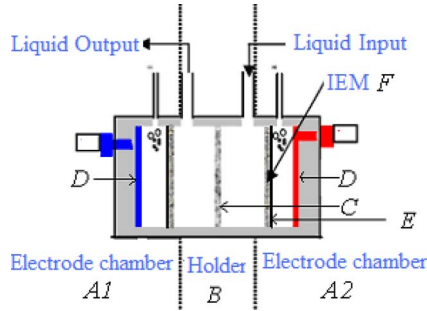

Fig. 6. Schematic design of the PEOP.

coefficient can be increased by two ways: using a liquid with a high-flow-rate pumping (for example, jet cooling) or using a heat exchanger with small ducts in order to increase the heat-transfer surface (for example, microchannel cooling). It has been shown in the introduction that the existing EO pumps can only produce tens of milliliters per minute, which makes it more adapted to microchannel heat exchangers. The problem with this kind of heat exchangers is that it needs a very high pressure, which is not easy to be generated with a classical mechanical pump. An advantage of the PEOP is that it can generate high pressures which makes it more adapted to microchannel heat exchangers.

We can conclude that convective cooling with evaporation is well adapted with PEOP because it requires a very low flow rate when compared with one-phase cooling systems. In case of forced convection with evaporation, the use of a pure liquid is necessary in order to avoid a precipitation in the heat exchanger. To study the possibility of using the PEOP in the forced convection, our pump has been tested with a pure liquid (DI water). The design and the experimental results of the PEOP are presented in the next paragraph.

#### IV. FABRICATION AND CHARACTERIZATION

##### A. Design

The schematic design of the PEOP is shown in Fig. 6. The PEOP can be divided into three parts: the anode chamber ( $A_1$ ), the cathode chamber ( $A_2$ ), and the porous disk holder ( $B$ ).

All of these parts are made of Plexiglas, which has the advantage of transparency and is easy to be machined.

1) *Electrode Chamber ( $A_{1,2}$ ):* Each electrode chamber contains one electrode made of carbon ( $D$ ), and the contact between carbon and external wire is assured by a gilded copper connector. The use of carbon avoids the corrosion of electrode. Next to the carbon electrode, there is a Plexiglas mesh ( $E$ ) which holds the ion exchange membrane (IEM) ( $F$ ). The role of the IEM is to keep a stable pH of the working fluid and to avoid the existence of gas bubbles (in the hydraulic circuit) generated by electrolysis in the electrode chambers. These IEMs have been fabricated by Fumatech@ company (Germany).

2) *Disk Holder ( $B$ ) and the Porous Disk ( $C$ ):* The disk holder is used to hold a sintered ceramic disk ( $C$ ). This disk is the heart of the pump. Indeed, when it is immersed in the liquid, a volume charge density will be created inside the holes of the porous medium due to the EDL phenomenon. When applying

TABLE I  
CHARACTERISTICS OF THE POROUS DISKS

	Silica disk	Alumina disk
Radius (cm)	2.5	2.5
Length (mm)	3.5	2
Effective pore radius ( $\mu\text{m}$ )	0.75	0.35
Porosity (%)	35	30
Tortuosity	<1.5	<1.5

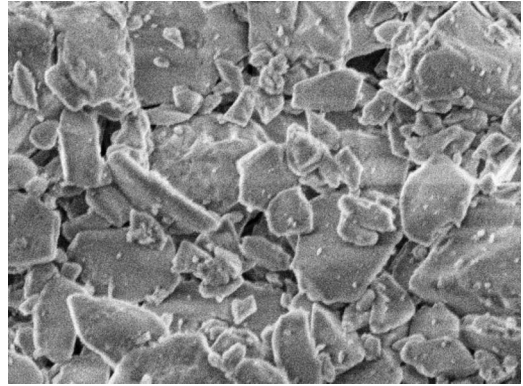

Fig. 7. SEM photograph of the porous sintered silica.

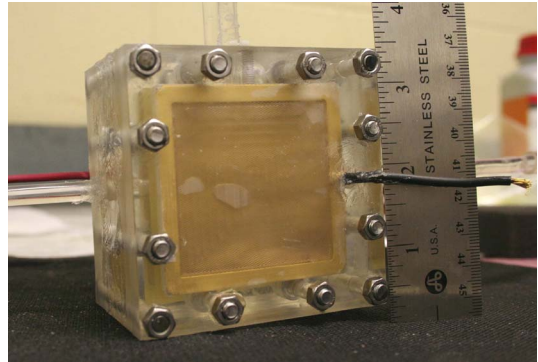

Fig. 8. Design of the PEOP.

a dc voltage by the electrodes, a Coulombic force creates the motion of this charge density as well as the liquid inside the porous disk.

Two sintered ceramic disks were used: silica and alumina. The characteristics of each disk are presented in Table I. A scanning electron microscope (SEM) photograph of the silica disk is shown in Fig. 7.

The volume of the prototype is  $80 \times 80 \times 60 \text{ mm}^3$  (Fig. 8). This volume could be reduced while keeping the same performance. Indeed in (4), we can see that the maximum flow rate depends on the ratio  $A/l$ . Therefore, if the cross section and the length of porous disk are reduced with the same factor, the maximum flow rate could be kept the same.

##### B. Experiments

1) *Metrology:* The characterization of the PEOP consists of determining the maximum pressure drop, the maximum flow rate, and the power consumption.

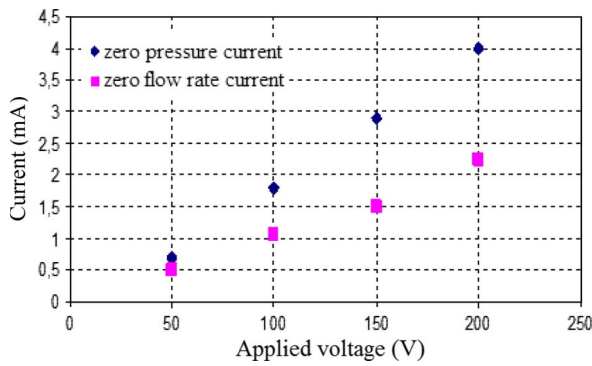

Fig. 9. Variation of the zero-pressure current and the zero-flow-rate current as a function of the applied voltage.

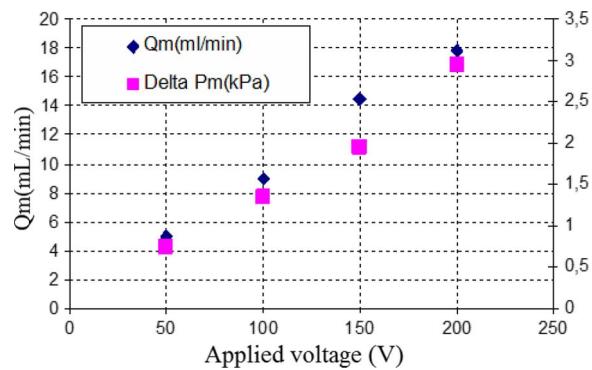

Fig. 10. Variation of the maximum pressure and the maximum flow rate as a function of the applied voltage.

In the maximum-pressure-drop measurement setup, the outlet of the PEOP pump is closed by a pressure sensor, which forbids the liquid motion; hence, the measured pressure is the maximum pressure drop generated by the PEOP. In these conditions, the current is called zero-flow-rate current ( $I_{P_m}$ ).

In the maximum-flow-rate measurement setup, the input and output of the pump are put at the same height, in order to have a very low pressure drop between the inlet and the outlet of the pump. Hence, the measured flow is the maximum flow rate given by the PEOP. The flow rate is measured by weighing the pumped liquid. In this case, the current is called zero-pressure current ( $I_{Q_m}$ ).

2) *Results and Analysis:* The PEOP has been first tested with the silica disk and DI water as pumping liquid. The applied voltage has been varied from 50 to 200 V.

The zero-pressure and zero-flow-rate currents consumed by the pump are shown in the Fig. 9. It can be seen that the current in maximum-flow-rate operation  $I_{Q_m}$  is higher because of the existence of two currents, the electromigration current and the electroconvection current. In case of maximum-pressure operation, the total current is lower because the electroconvection current is zero (there is no motion of the liquid). In both cases, the current consumed by the pump is low due to the very low value of the DI water conductivity.

We can see in Fig. 10 that the maximum flow rate  $Q_m$  and the maximum pressure  $\Delta P_m$  increase linearly with the applied voltage, which can be explained by (4) and (5). The PEOP can generate 13.6 mL/min and 1.9 kPa at 150 V. The electric power used by the pump at 150 V is only 217.5 mW, and it gives a



Fig. 11. Disk applied voltage measurement method.

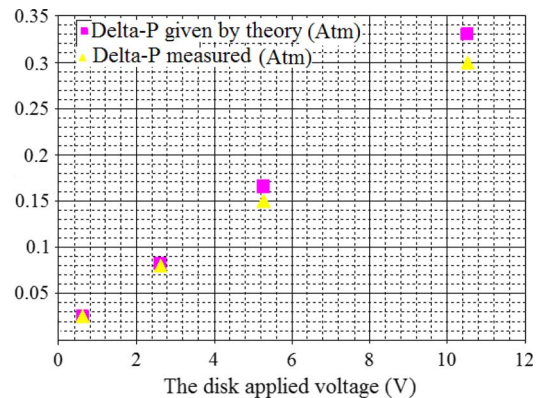

Fig. 12. Model validation: maximum pressure.

hydraulic power of 0.47 mW; hence, the thermodynamic efficiency is 0.2%. With such a PEOP, it is possible to cool 22.6 W without evaporation and 271.4 W with evaporation. In each case, the power consumption of the PEOP stays very low when compared to the heat power that can be evacuated. The pump works without any noise compared to the mechanical pumps and without any bubbles in the hydraulic circuit.

### C. Comparison Between Theory and Experiments

In order to compare the theory and experiments, we need to measure the real applied voltage to the porous disk. To do that, we assume that the voltage is equipotent on both faces of the disk. Then, we measure the voltage on one point of each face of the disk. To do this, we glued two multilegged threads with silver glue (Fig. 11). For these measurements, the used disk was the alumina one.

The theoretical and experimental flow-rate- and pressure-value comparisons are shown in Figs. 12 and 13. It can be seen that the real voltage applied to the disk is very low when compared to the one applied to PEOP (an applied 150-V voltage at the electrodes induces only a 10.5-V voltage on the porous sintered disk). That can be explained by the electrical losses between the electrode and the disk surface (conduction losses in the liquid and in IEM).

In Fig. 12, it can be seen that the maximum pressure increases with the voltage. We can also see that the theoretical values of the maximum pressure are very close to the experimental ones.

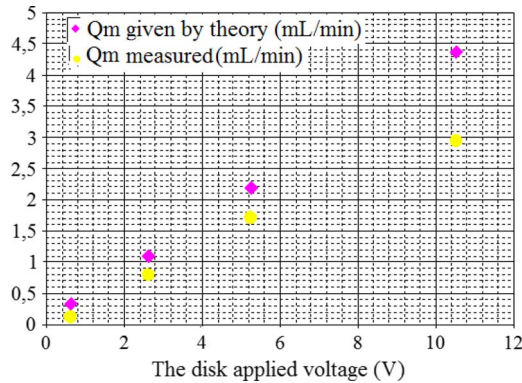

Fig. 13. Model validation: maximum-flow-rate comparison.

In Fig. 13, it can be observed that the comparison between the experimental values of the flow rate and the theory is less precise. In fact, the tortuosity appears in the maximum-flow-rate formula (4), which is a parameter that is very difficult to be measured precisely.

These experiments show us that the use of the alumina disk provides a higher pressure (0.3 atm = 30 kPa with alumina and 11 kPa with silica) and a lower flow rate (3 mL/min with alumina and 14 mL/min with silica). This could be explained by the physical properties of each material (zeta potential, for example) but we think that this difference is principally due to the geometrical characteristics of these devices: Indeed the lower pore radius of the alumina disk induces a higher contact surface between the wall and the fluid and, thus, a higher Coulombic force. However, this low pore radius increases the viscous losses and therefore decreases the flow rate.

## V. CONCLUSION

In this paper, we have presented an analytical expression for the flow rate, pressure, and thermodynamic efficiency of a PEOP. Then, we have presented the realization and tests of a PEOP. Using DI water as pumping liquid and a silica disk as porous media, the pump generates 13.6 mL/min and 1.9 kPa at 150 V and 18.7 mL/min and 2.95 kPa at 200 V, and the electrical power consumption of the pump is less than 0.4 W. The thermodynamic efficiency is low (0.2%) but the power consumption of the PEOP stays very low compared to the heat power that can be cooled using this PEOP (274 W with convective cooling with evaporation). The PEOP works without any noise, and no bubbles were observed in the hydraulic circuit. We have also compared the experimental results with the proposed model. There was a good agreement between them, particularly for the pressure calculation.

## REFERENCES

- [1] C. Gillot, L. Meysenc, and C. Schaeffer, "Integrated single and two-phase micro heat sinks under IGBT chips," *IEEE Trans. Compon. Packag. Technol.*, vol. 22, no. 3, pp. 384–389, Sep. 1999.
- [2] V. Proetorius, B. J. Hopkins, and J. D. Schieke, "Electroosmosis a new concept for high-speed liquid chromatography," *J. Chromatogr.*, vol. 99, pp. 23–30, 1974.
- [3] F. Theeuwes, "Elementary osmotic pump," *J. Pharm. Sci.*, vol. 64, no. 12, pp. 1987–1991, Dec. 1975.

- [4] P. H. Paul, D. W. Arnold, and D. J. Rakestraw, "Electrokinetic generation of high pressures using porous microstructures," in *Proc. microTAS*, Banff, AB, Canada, 1998, pp. 49–52.
- [5] S. Zeng, C. Chen, J. C. Mikkelsen, and J. G. Santiago, "Fabrication and characterization of electrokinetic micro pumps," *Sens. Actuators B, Chem.*, vol. 79, no. 2/3, pp. 107–114, Oct. 2001.
- [6] S. Zeng, C. H. Chen, J. G. Santiago, J.-R. Chen, R. N. Zare, J. A. Tripp, F. Svec, and J. M. J. Fréchet, "Electroosmotic flow pumps with polymer frits," *Sens. Actuators B, Chem.*, vol. 82, no. 2/3, pp. 209–212, Feb. 2002.
- [7] K. Goodson, J. Santiago, T. Kenny, L. Jiang, S. Zeng, J.-M. Koo, L. Zhang, S. Yao, and E. Wang, "Closed-loop electroosmotic microchannel cooling system for VLSI circuits," *IEEE Trans. Compon. Packag. Technol.*, vol. 25, no. 3, pp. 347–355, Sep. 2002.
- [8] A. Brask, "Electroosmotic micropumps," Ph.D. dissertation, Dept. Micro Nanotechnol., Tech. Univ. Denmark, Copenhagen, Denmark, 2005.
- [9] C. L. Rice and R. Whitehead, "Electrokinetic flow in a narrow cylindrical capillary," *J. Phys. Chem.*, vol. 69, no. 11, pp. 4017–4024, 1965.
- [10] P. Wang, Z. Chen, and H.-C. Chang, "A new electro-osmotic pump based on silica monoliths," *Sens. Actuators B, Chem.*, vol. 133, no. 1, pp. 500–509, Jan. 2005.
- [11] Y. Takamura and A. Oki, "Low voltage electroosmosis pump for stand-alone microfluidics devices," *Electrophoresis*, vol. 24, no. 12, pp. 185–192, Jan. 2003.
- [12] Z. Chen and T. Hobo, "Chemically L-prolinamide-modified monolithic silica column for enantiomeric separation of dansyl amino acids and hydroxy acids by capillary electrochromatography and  $\mu$ -high performance liquid chromatography," *Electrophoresis*, vol. 22, no. 15, pp. 3339–3346, Sep. 2001.
- [13] Z. Chen and T. Hobo, "Chemically L-phenylalaninamide-modified monolithic silica column prepared by a sol-gel process for enantioseparation of dansyl amino acids by ligand exchange-capillary electrochromatography," *Anal. Chem.*, vol. 73, no. 14, pp. 3348–3357, Jul. 2001.
- [14] F. C. Leinweber, D. Lubda, K. Cabrera, and U. Tallarek, "Characterization of silica-based monoliths with bimodal pore size distribution," *Anal. Chem.*, vol. 74, no. 11, pp. 2470–2477, Jun. 2002.
- [15] Y. Berrouche, Y. Avenas, C. Schaeffer, P. Wang, and H.-C. Chang, "Optimization of high flow rate nanoporous electroosmotic pump," *Trans. ASME, J. Fluids Eng.*, vol. 130, no. 8, pp. 081 604-1–081 604-7, Aug. 2008.



**Youcef Berrouche** received the B.S. degree from the Department of Electrical Engineering, National Polytechnic School of Algeria ENP, Alger, Algeria, in 2004, and the M.Sc. and Ph.D. degrees from the Grenoble Electrical Engineering Laboratory (G2Elab), Grenoble Institute of Technology, Grenoble, France, in 2005 and 2008, respectively.

His research focused on replacement of the mechanical pump used in electronics cooling systems by a porous electro-osmotic pump. He is currently with Concordia University, Montréal, QC, Canada, and his fields of interest are renewable energy, energy storage, and energy efficiency.



**Yvan Avenas** received the Ph.D. degree from Grenoble Institute of Technology, Grenoble, France, in 2002.

He is currently a Teacher and Researcher at Grenoble Institute of Technology. He works in the field of power electronic cooling by passive heat exchangers (miniature heat pipes and pulsating heat pipes) and by static devices using electrohydrodynamics, magnetohydrodynamics, and thermomagnetic forces.



**Christian Schaeffer** received the Ph.D. degree in electrical sciences and engineering from Grenoble Institute of Technology (INPG), Grenoble, France, in 1992.

He is a Professor at INPG, where he has been the Vice Academic since 2008. Since 1993, he has been conducting research on power electronic integration, in which his main fields of research are thermal behavior, micro cooling systems, micro heat pipes, and packaging of power electronic components.



**Ping Wang** was born in Anhui, China, in 1977. He received the B.S. and M.S. degrees in chemical engineering from Tsinghua University, Beijing, China, in 2002, and the Ph.D. degree from the University of Notre Dame, Notre Dame, IN, in 2007.

Upon graduation, he joined Chevron as a Research Engineer in the Lubricant Additive Division, where he works on research and development of new-generation detergents and clean and ecofriendly fuels and lubricants.



**Hsueh-Chia Chang** received the B.S. degree from California Institute of Technology, Pasadena, in 1976, and the Ph.D. degree from Princeton University, Princeton, NJ, in 1980, both in chemical engineering.

He is currently the Bayer Professor of Engineering at the University of Notre Dame, Notre Dame, IN, where he is also the Director of the Center for Microfluidics and Medical Diagnostics. He is the Editor of *Biomicrofluidics*, an American Institute of Physics journal. He specializes in dc and ac electrokinetics, which is an important field in microfluidics. He has authored many journal publications and review papers on the subject. He is the author of the book *Electrokinetically Driven Microfluidics and Nanofluidics* (Cambridge University Press, 2009). His Ph.D. and postdoctoral students have embarked on their own microfluidic research as faculty members at Tennessee, Florida, Rutgers, Mississippi State University, University of California, San Diego, Missouri, and Johns Hopkins in the U.S. and at leading institutions in Australia (Monash University), Israel (Technion—Israel Institute of Technology), Taiwan (National Cheng Kung University), and China (Wuhan University).

He is currently the Bayer Professor of Engineering at the University of Notre Dame, Notre Dame, IN, where he is also the Director of the Center for Microfluidics and Medical Diagnostics. He is the Editor of *Biomicrofluidics*, an American Institute of Physics journal. He specializes in dc and ac electrokinetics, which is an important field in microfluidics. He has authored many journal publications and review papers on the subject. He is the author of the book *Electrokinetically Driven Microfluidics and Nanofluidics* (Cambridge University Press, 2009). His Ph.D. and postdoctoral students have embarked on their own microfluidic research as faculty members at Tennessee, Florida, Rutgers, Mississippi State University, University of California, San Diego, Missouri, and Johns Hopkins in the U.S. and at leading institutions in Australia (Monash University), Israel (Technion—Israel Institute of Technology), Taiwan (National Cheng Kung University), and China (Wuhan University).